

GOVERNMENT OF INDIA

ARCHÆOLOGICAL SURVEY OF INDIA

CENTRAL
ARCHÆOLOGICAL
LIBRARY

ACCESSION NO. 33798.

CALL No. 913.3937/G.L.S.I.I.

D.G.A. 79.



777

THE SWEDISH CYPRUS EXPEDITION

FINDS AND RESULTS OF THE
EXCAVATIONS IN CYPRUS

75198

1927—1931

VOL. III. TEXT ~~14859~~

BY

EINAR GJERSTAD

JOHN LINDROS

ERIK SJÖQVIST

ALFRED WESTHOLM



12.3737
W.

314
22-11-39
~~656472~~ 342.
J.L.

THE SWEDISH CYPRUS EXPEDITION
STOCKHOLM

PUBLISHED WITH A CONTRIBUTION F
HUMANISTISKA FONDEN, STOCKHO

PRINTED IN SWEDEN

CENTRAL ARCHAEOLOGICAL
LIBRARY, NEW DELHI
No. 33796
13.5.58
913-3937

G. L. S. W.

COPYRIGHT BY THE SWEDISH CYPRUS EXPED
STOCKHOLM

PRINTED BY
VICTOR PETTERSONS BOKINDUSTRIAKTIEB
STOCKHOLM 1937

P R E F A C E

It is very regrettable that the publication of the third volume of the Swedish Cyprus Expedition has been delayed about a year. This is due to the circumstance that the members of the Expedition have had to devote a great deal of their time to other work. It is also anticipated that the publication of the fourth volume will be somewhat delayed for the same reason.

I also avail myself of this opportunity to express the sincere gratitude of the Expedition to all those who have assisted in and contributed towards the publication of the third volume.

Miss Joan du Plat Taylor, Miss Kathleen M. Kenyon, Mrs. Vivi Gjerstad, Miss Margareta Sjöqvist, Messrs. Bror Millberg, Alfred Westholm, and Tooulis Svidos have assisted in the same kind of work as before. Miss Margit Hallberg has devoted much competent and painstaking work to the preparation of the illustrations and plates, typing MSS., and reading proofs, etc., Mr. O. Åhrberg has revised the MSS. from a typographical point of view, and his great ability in this respect has greatly facilitated the printing of this volume.

Prof. Axel W. Persson has kindly undertaken to publish the Cypro-Minoan inscriptions found by the Expedition (Appendix I). Prof. Wilh. Riedel has published some Phoenician inscriptions (Appendix II), Dr. Erik Ekman a number of Greek inscriptions (Appendix III), and Mr. John L. Bruce a study on Antiquities in the mines of Cyprus (Appendix V). Finally, in Appendix VI there is an examination of the different materials used for stone sculptures based on informations supplied by Dr. Nils Zenzén.

The Expedition has received 5,000: — Swed. Crowns from "Humanistiska Fonden" and 5,000: — Swed. Crowns from "Fonden för tryckning av lärda verk" as a contribution towards covering the expenses of printing.

The reproductions are by the same firms as those in the previous volumes.

EINAR GJERSTAD

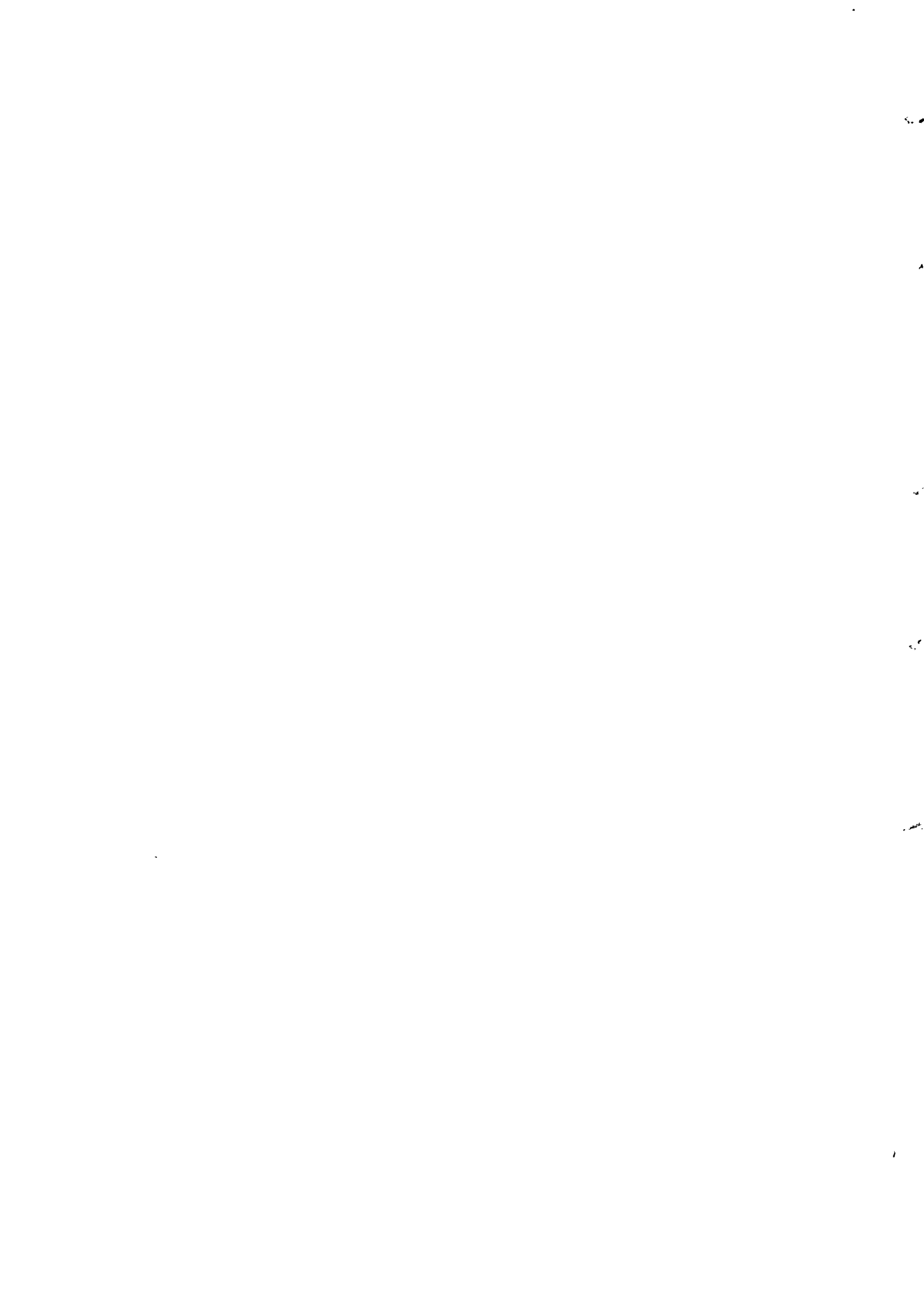

C O N T E N T S

	Page
PREFACE	III
CONTENTS	VII
LIST OF ILLUSTRATIONS IN THE TEXT	VII
LIST OF PLANS	XIV
LIST OF PLATES	XVI
KITION	I
Introduction, p. 1; Architecture, p. 2; Architectural elements, p. 2; Stratification, p. 9; Architectural analysis, p. 16; Architectural synthesis, p. 18; Finds, Object Register, p. 26; Classification of Finds, p. 54; Conditions of Finds, p. 63; Chronology, p. 67; Summary, p. 74.	
VOUNI	76
Introduction, p. 76; Topography, p. 76.	
THE TEMPLE OF ATHENA, p. 85; Architecture, p. 85; Architectural elements, p. 85; Stratification, p. 92; Architectural Analysis and Synthesis, p. 93; Finds, Object Register, p. 97; Classification of Finds, p. 103; Conditions of Finds 108; Identification of the temple, p. 109; Chronology, p. 110.	
THE PALACE, p. 111; Architecture, p. 111; Architectural elements, p. 111; Sections and stratification, p. 175; Architectural analysis, p. 187; Architectural synthesis, p. 202; Finds, Object Register, p. 229; Classification of Finds, p. 262; Conditions of Finds, p. 277; Chronology, p. 280.	
LOURES, p. 291.	
PARADISOTISSA, p. 292; Topography, p. 292; Architecture, p. 294; Stratification, p. 296; Architectural synthesis, p. 296; Finds, p. 296; Classification of Finds, p. 297.	

THE NECROPOLIS AT KORAKAS, p. 298; Tomb 1, p. 300; Tomb 2, p. 303; Tomb 3, p. 305; Tomb 4, p. 309; Tomb 5, p. 311; Tomb 6, p. 311; Tomb 7, p. 313; Tomb 8, p. 315; Tomb 9, p. 320; Tomb 10, p. 322; Tomb 11, p. 322; Tomb 12, p. 324; Tomb 13, p. 327; Tomb 14, p. 332; Tomb 15, p. 333; Tomb 16, p. 335; Summary, p. 338.

MERSINAKI 340

Introduction, p. 340; Architectural remnants, p. 342; Stratification, p. 344; Finds, Object Register, p. 351; Classification of Finds, p. 380; Chronology, p. 393.

SOLI 399

Topography, p. 399; Notes on some ancient records of Soli, p. 405.

THE ACROPOLIS, p. 412; Finds, p. 413; Object Register, p. 414; Classification of Finds, p. 414.

THE TEMPLES AT CHOLADES, p. 416; Architecture, p. 416; Material and Construction, p. 416; Architectural elements, p. 420; Stratification, p. 460; Architectural analysis, p. 472; Architectural synthesis, p. 481; Reconstruction of the temples, p. 491; Finds, Object Register, p. 494; Classification of Finds, p. 509; Conditions of Finds, p. 533; Relative chronology, p. 537; Absolute Chronology, p. 540; Identification of the temples, p. 543.

THE THEATRE, p. 548; Architecture, p. 548; Architectural elements, p. 548; Stratification, p. 562; Architectural synthesis, p. 563; Finds, Object Register, p. 574; Classification of Finds, p. 577; Conditions of Finds, p. 580; Chronology, p. 581.

ARSOS 583

APPENDIX I 601

APPENDIX II 619

APPENDIX III 621

APPENDIX IV 633

APPENDIX V 639

APPENDIX VI 672

NOTES 673

LIST OF ILLUSTRATIONS IN THE TEXT

Fig.	Page	Fig.	Page
1	Kition. The Acropolis seen from the South	2	26 Kition. Detail of the deposit of sculptures
2	Kition. The Acropolis seen from the East	3	27 Kition. Detail of the deposit of sculptures
3	Kition. In the foreground: Altar 36, Walls 3, 8 A—B, and 9; in the background: Walls 3 and 4	4	28 Kition. Group of sculptures leaning against the sup- posed boards in the lower pit
4	Kition. Walls 7 A—B to the right; Altar 36 and the base of the cult-statue (No. 560) in the background	4	29 Kition. Group of Fig. 28 seen from the side
5	Kition. Walls 23 B, 28—33 in the foreground; Walls 17—19 and Altar 40 in the background	4	30 View of Vouni from the West
6	Kition. Walls 23 A and B	5	31 View of Vouni from the acropolis hill of Soli
7	Kition. Wall 23 A to the left, Wall 21 in the middle, and the N. E. end of Wall 20 to the right	5	32 Vouni from the South
8	Kition. Press in Room XXI	5	33 Vouni. View towards the South from the summit
9	Kition. Altars 39 and 40	6	34 Vouni. View of the plane of Soli from the summit. In the foreground, left, the site of Mersinaki
10	Kition. From the left: Altars 39, 38, Platform 34, and Altar 37; below: Walls 3 and 5	6	35 Vouni. View of Petra tou Limniti from the slope of the hill
11	Kition. Floor of Type 3 at level 66.5 in Square K 4	7	36 Vouni. On the shore
12	Kition. Part of Section I with slabs of Platform 35	7	37 Vouni. The temple of Athena. Room II
13	Kition. Section I B, with slabs of Platform 35 to the right	8	38 Vouni. The temple of Athena. E. portion
14	Kition. Detail of Section I B, with slabs of Platform 34 to the right	8	39 Vouni. The entrance into the sanctuary of Athena
15	Kition. Analytical plan of the excavated area	8	40 Vouni. The temple of Athena. The floor-level of Room II indicated on the façade of Wall 3 of the sanctuary
16	Kition. Plan of the architecture of Periods 1—3(1), Period 4(2), and Periods 5—6(3)	10	41 Vouni. The temple of Athena. The entrance be- tween Rooms III and IV
17	Kition. Plan of the architecture of Periods 7—8	11	42 Vouni. The temple of Athena. Stair 19 from the E.
18	Kition. Plan of the architecture of Periods 9—10	17	43 Vouni. The temple of Athena. Altar 20
19	Kition. The central part of the excavated area with the depository pits for the sculptures. In the back- ground: Platforms 34, 35. In the foreground, from the left: Altars 38, 37, 36, Walls 7—8: A—B	18	44 Vouni. The temple of Athena. Joint between Walls 3 and 5
20	Kition. Detail of the central part of the excavation, with Altar 36, Walls 3 and 7—8: A—B	19	45 Vouni. The sanctuary of Athena (Room I), N. E. corner, floor removed
21	Kition. View of the house of Periods 9—10, from the West	20	46 Vouni. The temple of Athena, Layers near Wall 9
22	Kition. View of the house of Periods 9—10, from the East	20	47 Vouni. The temple of Athena. Analytical plan and conjectural, reconstructed sketch
23	Kition. The deposit of sculptures in the rectangular pit. The "innermost stratum", resting on slabs of Platform 34	23	48 Vouni. The temple of Athena. The bronze cow, No. 152, <i>in situ</i>
24	Kition. The deposit of sculptures after removal of the "front stratum"	24	49 Vouni. The temple of Athena. Spear-heads, Nos. 167 and 168, <i>in situ</i>
25	Kition. The deposit of sculptures before removal	25	50 Vouni. The central part of the palace area before ex- cavation
		63	51 Vouni. The palace during excavation. Female worker with masculine strength
		64	52 Vouni. The palace during excavation. Pause in the work
		65	53 Vouni. The palace during excavation

54	Vouni. The palace during excavation	115	77	Vouni. The palace. Rooms 62 and 63 from the S. W. Walls 148 (foreground), 130 (left), 101 (right), and 149 (background)	135
55	Vouni. The palace. Walls 1 (left) and 73 (right)	116	78	Vouni. The palace. Walls of Rooms 75—77, with the hearth of Room 75, in the foreground; Walls of Rooms 96 and 97 in the background	135
56	Vouni. The palace. Walls 1 (background, left), 73 (foreground, left), and 155 (right). Part of inner face of Wall 155 removed in order to show the structural interrelations of the walls. Part of Walls 126, 127, and the staircase between Rooms 57 and 65 furthestmost in the background	116	79	Vouni. The palace. Walls 63 (left) and 64 A (right), from the N. E.	137
57	Vouni. The palace. Part of staircase between Rooms 55 and 64, traces of Wall 129 and Wall 130 (right), Wall 131 (background)	117	80	Vouni. The palace. Walls 63 (left) and 64 A (right), from the East	140
58	Vouni. The palace. The corner between Walls 129—131	117	81	Vouni. The palace. Walls 64 B (foreground) and 64 A (background), from the N. W.	140
59	Vouni. The palace. Walls 73 (left) and 155 (right) in the foreground. Part of the core of the latter wall removed. Foremost in the background: Wall 1; furthestmost: Walls 35, 126, 127, and the staircase between Rooms 57 and 65	118	82	Vouni. The palace. The roof of the fire-rooms of the sudatory	141
60	Vouni. The palace. Entrance into Room 95, with the doorway narrowed by later additions	118	83	Vouni. The palace. Interior of Room 85 of the hot bath with outlet for the drainage channel in Wall 58	141
61	Vouni. The palace. Room 93. Walls 68 (right), 69 (left), and 71 (background), with the doorway blocked up	120	84	Vouni. The palace. Walls of Rooms 21—23 from the N. E.	143
62	Vouni. The palace. Walls of Rooms 93 (left) and 92 (right)	121	85	Vouni. The palace. S. W. face of Wall 191	145
63	Vouni. The palace. Room 97. Walls 25 (foreground), 21 (left), 22 (right), and 26 (background)	122	86	Vouni. The palace. Entrance into Room 45 with impressions of the wooden door-posts	147
64	Vouni. The palace. Wall 68	122	87	Vouni. The palace. Floor of Room 51; Walls 1 and 3 in the background	147
65	Vouni. The palace. Room 12. Walls 15 (foreground), 9 (right), 10 (left), and 18 (background)	123	88	Vouni. The palace. The column base in the E. corner of the central court with a small piece of the column shaft placed in position	155
66	Vouni. The palace. The S. E. part of Room 13 with the rock cavity after excavation. Walls 76 (foreground), 18 (right), 9 (foremost in the background), and 10 (furthestmost in the background)	123	89	Vouni. The palace. The column base in the E. corner of the central court. Remains of melted lead for fixing the column to the base	155
67	Vouni. The palace. Room 88. Walls 59 (left), 60 (right), and 70 (background)	125	90	Vouni. The palace. Staircase leading from the road along the N. E. front of the main temenos to Room 122 and the cemented water-conduit along the S. E. side of the staircase. In the background: staircase between Rooms 121 and 122	157
68	Vouni. The palace. Room 86. Walls 61 (left), 63 (right), and 58 (background)	125	91	Vouni. The palace. Threshold slabs of gate of Room 100	157
69	Vouni. The palace. Walls 56, 133, and staircase between Rooms 46 and 60 (foreground, left), Wall 191 (foreground, right), Walls or Rooms 48—56 and the staircase between the central court and Rooms 48—51—54 (background)	126	92	Vouni. The palace. Staircase between Rooms 27 and 57	159
70	Vouni. The palace. In the foreground: Walls 55 and 133; in the background: Walls of Rooms 48—51—54 and the staircase (after restoration) between these rooms and the central court	127	93	Vouni. The palace. Staircase between Rooms 55 and 64; Walls 128 and 130 to the right	159
71	Vouni. The palace. Room 43+44. Wall 52; Wall 183 has been removed	129	94	Vouni. The palace. Staircase between Rooms 46 and 60 through Wall 56	161
72	Vouni. The palace. Room 42. Walls 50 (background) and 52 (right)	129	95	Vouni. The palace. Staircase between Rooms 7 A and 37	161
73	Vouni. The palace. Walls of Rooms 103—105	131	96	Vouni. The palace. Staircase between Rooms 31 and 32; Walls 107 (right) and 137 (left)	163
74	Vouni. The palace. Walls of Room 101	131	97	Vouni. The palace. Staircase between Rooms 26 and 28	163
75	Vouni. The palace. Wall 183	133	98	Vouni. The palace. Cemented basin of water-conduit in Room 28	164
76	Vouni. The palace. Doorway of Room 44 blocked up with rubble	133	99	Vouni. The palace. Cemented basin of water-conduit in Room 26	164
			100	Vouni. The palace. Mouth of the cistern in the S. E. court (Room 83)	165
			101	Vouni. The palace. Room 91	165
			102	Vouni. The palace. Cemented water-conduit below the floor of Room 28	166

103	Vouni. The palace. Room 76. Sink (left) and waste-conduit (right)	166	125	Vouni. The palace. View of the central court from the West	208
104	Vouni. The palace. Room 61. The cistern in the foreground and Wall 147 with a rectangular hole for a drainage channel	168	126	Vouni. The palace. View towards the West from Room 44. Remains of a water-conduit in the W. corner of the room	209
105	Vouni. The palace. The circular wall of the bottle-shaped cistern built into the tank-cistern in the central court	168	127	Vouni. The palace from the West with the store-rooms 10—14 in the foreground	211
106	Vouni. The palace. Drainage channel in Room 124 with Wall 184 in the background and Wall 185 to the right	169	128	Vouni. The palace from the S. W.	211
107	Vouni. The palace. Drainage channel along the S. W. exterior wall of the main temenos; Room 122 to the left in the background	169	129	Vouni. The palace. View towards the S. W. from Room 31	214
108	Vouni. The palace. The substructure for the mouth of the bottle-shaped cistern in the central court. Part of tank-cistern behind. Staircase between the central court and Rooms 48—51—54 in the background . . .	170	130	Vouni. The palace. View towards the N. E. from Room 19	215
109	Vouni. The palace. The substructure for the mouth of the bottle-shaped cistern in the central court with one stele of the hoisting structure placed in position. Behind the cistern, part of a cylindrical column erected on one of the peristyle bases. Walls of Rooms 42—44 in the background. The damaged floor around the cistern restored with straight edges	171	131	Vouni. The palace seen from its W. corner. Store-rooms 10—14 in the foreground	216
110	Vouni. The palace. W. part of the central court before restoration. Mouth of the cistern to the right; Rooms 43—45 in the background	172	132	Vouni. The palace. The N. W. complex of rooms with Room 8 in the foreground	217
111	Vouni. The palace. Room 22. Cemented outlet for the water	173	133	Vouni. The palace. Part of the kitchen departement seen towards the S. E. from the courtyard 64. Rooms 73—76 in the foreground	218
112	Vouni. The palace. Cemented water-basin in Room 106	173	134	Vouni. The palace. The house outside the S. corner of the palace, with Rooms 107—108 in the foreground	219
113	Vouni. The palace. Semicircular altar in the main temenos (Room 123)	175	135	Vouni. The palace. The S. E. court from the S. W.	222
114	Vouni. The palace. Altar in the cult-chapel, Room 117	175	136	Vouni. The palace. The N. E. part of the S. E. court (Room 83) with Room 84 in the foreground, Rooms 86—88 to the left, Rooms 92—94 in the background, and the cistern to the right	223
115	Vouni. The palace. Section through the floors of Room 57	182	137	Vouni. The palace. Room 111 of the house outside the S. corner of the palace	224
116	Vouni. The palace. Section below the floor of Room 7 A	182	138	Vouni. The palace. The entrance into the altar court (Room 123) of the main temenos with bases for statues <i>in situ</i>	224
117	Vouni. The palace. Layers below the floor of Room 39	183	139	Vouni. The palace. View of the main temenos from the S. E. Drainage channel to the left, the fore-court and the altar court to the right	226
118	Vouni. The palace. The filling of the tank-cistern in the central court	183	140	Vouni. The palace. The front rooms of the main temenos with Room 129 in the foreground	227
119	Vouni. The palace. Analytical Plan	188—189	141	Vouni. The palace. Room 127 of the main temenos, seen from the East	228
120	Vouni. The palace. Plan of 1st period	191	142	Vouni. The palace. The cult-chapel, Room 117	228
121	Vouni. A model of the palace, seen from the N. W. The columns of the peristyle, the mouth of the cistern in the central court, and the staircase in Room 7 A are reconstructed, the latter in a somewhat wrong way	201	143	Vouni. Inscriptions of Coins Nos. 292 t: 1—16	239
122	Vouni. The palace. View of the central court with the adjoining rooms, from the N. E.	203	144	Vouni. Inscriptions of Coins Nos. 292 t: 17—29	240
123	Vouni. The palace. View of the central court with the adjoining rooms, from the East	203	145	Vouni. Inscriptions of Coins Nos. 292 t: 30—43	241
124	Vouni. The palace. View of the reception rooms (48—56) from the S. W., with the central court in the background	205	146	Vouni. Inscriptions of Coins Nos. 292 t: 44—49, 57, 59—69	242
			147	Vouni. Inscriptions of Coins Nos. 292 t: 70—82, 87, 127; 292 v; 1—3	243
			148	Vouni. The palace. Room 10. Pithoi <i>in situ</i>	277
			149	Vouni. The palace. The fore-court (Room 122) of the main temenos, with finds Nos. 16 and 17 <i>in situ</i>	277
			150	Vouni. The palace. Room 129 of the main temenos. Sculptures <i>in situ</i>	278
			151	Vouni. The palace. Sculptures <i>in situ</i> inside the entrance to the altar court (Room 123) of the main temenos	278
			152	Vouni. The palace. Sculptures <i>in situ</i> inside the entrance to the altar court (Room 123) of the main temenos	279

153	Vouni. The palace. Sculptures found in Room 129 of the main <i>temenos</i>	279	189	Mersinaki. View of the excavation	344
154	Vouni. The palace. Sculptures found <i>in situ</i> in the chapel, Room 117	279	190	Mersinaki. Remains of a house S. of the <i>temenos</i>	344
155	Vouni. The palace. Lower part of terracotta statue, No. 518, found in the chapel, Room 133	279	191	Mersinaki. Section through layers above the <i>temenos</i> floor	345
156	Vouni. The palace. Room 59. The gold and silver treasure <i>in situ</i>	280	192	Mersinaki. Section through layers above the <i>temenos</i> floor	345
157	Vouni. The palace. Room 65. Stone in Wall 180, incised with the syllabary sign for <i>pa</i>	280	193	Mersinaki. Layers resting on the rubble	347
158	Vouni. Loures. Trial excavation D. Column base <i>in situ</i>	291	194	Mersinaki. The filling in a pit distinguished from the virgin soil	347
159	Paradisotissa. The temple seen from the East	291	195	Mersinaki. View of the excavation	349
160	The valley of Paradisotissa from the sea	293	196	Mersinaki. View of the excavation	349
161	The valley of Paradisotissa from the South	294	197	Mersinaki. The filling of Pit VII (left) distinguished from the surrounding virgin soil (right). In the foreground, the bottom layer of pebbles	350
162	Vouni. Tomb 1, Plan (1); Section (2); Finds <i>in situ</i> (5). Tomb 2, Plan (3); Section (4); Finds <i>in situ</i> (6)	299	198	Mersinaki. Detail of filling in Square H 14	350
163	Vouni. Tomb 2. Finds <i>in situ</i>	304	199	Mersinaki. Finds <i>in situ</i> in Squares J 19 and H 19	390
164	Vouni. Tomb 4. Entrance into the chamber	304	200	Mersinaki. Finds <i>in situ</i> in Square J 19	391
165	Vouni. Tomb 3. Deposit in dromos	306	201	Mersinaki. Finds <i>in situ</i> in Square K 20	391
166	Vouni. Tomb 3. Complete vases in the debris of the collapsed roof	306	202	Mersinaki. Finds <i>in situ</i> in Square J 19	392
167	Vouni. Tomb 3, Plan (1); Section (2); Finds <i>in situ</i> (3). Tomb 4, Plan (4); Sections (5, 6). Tomb 6, Plan (7); Sections (8, 9); Finds <i>in situ</i> (10)	310	203	Mersinaki. Finds <i>in situ</i> in Square L 19	392
168	Vouni. Tomb 3. Door-packing	312	204	Mersinaki. Finds <i>in situ</i> in Squares I 20—21	393
169	Vouni. Tomb 6. Dromos	312	205	Mersinaki. Finds <i>in situ</i> in Pit V	393
170	Vouni. Tomb 8. Dromos with offering pithos <i>in situ</i>	316	206	Mersinaki. Finds <i>in situ</i> in Pit V	394
171	Vouni. Tomb 10. Skeleton <i>in situ</i>	316	207	Mersinaki. The bottom of Pit V, since the finds had been removed	394
172	Vouni. Tomb 7, Plan (1); Section (2); Finds <i>in situ</i> (3). Tomb 8, Plan (5); Sections (4, 6)	319	208	Mersinaki. Finds <i>in situ</i> in Pit II	395
173	Vouni. Tomb 8, Finds <i>in situ</i> (1). Tomb 9, Plan (2); Sections (3, 4). Tomb 10, Plan (5); Section (6)	321	209	Mersinaki. Finds <i>in situ</i> in Pit II	395
174	Vouni. Tomb 7. Finds <i>in situ</i>	323	210	Mersinaki. Finds <i>in situ</i> in Pit VI	397
175	Vouni. Tomb 8. Rear wall of the chamber	323	211	Mersinaki. Carbonized olive tree on the bottom of Pit VI	397
176	Vouni. Tomb 11, Plan (1); Section (2); Finds <i>in situ</i> (3, 5). Tomb 12, Finds <i>in situ</i> (4)	325	212	Soli. General view	399
177	Vouni. Tomb 12. Dromos	326	213	Soli. View from Cholades of the acropolis hill. The western city gate lies just above the large olive tree in the middle of the figure	400
178	Vouni. Tomb 14. Dromos	326	214	Soli. View from S. E. of the acropolis hill	401
179	Vouni. Tomb 12, Plan (1); Sections (2, 3). Tomb 13, Plan (4); Sections (5, 6)	328	215	Soli. View from the acropolis of the southern necropolis area. The holes visible in the ground are tombs, rifled just before the arrival of the expedition	404
180	Vouni. Tomb 11. Skeleton <i>in situ</i>	329	216	View of the valley of the Kambos river	411
181	Vouni. Tomb 12. Skeletons <i>in situ</i>	329	217	Soli. Plan of the temple on the acropolis	412
182	Vouni. Tomb 13, Finds <i>in situ</i> (1). Tomb 14, Finds <i>in situ</i> (2); Plan (4); Sections (3, 5, 6)	331	218	Soli. Acropolis. Preserved foundation walls of the temple	413
183	Vouni. Tomb 14. Interior view	334	219	Soli. Monastraki. Column and capitals <i>in situ</i>	413
184	Vouni. Tomb 14. Detail of a wall	334	220	Soli. Cholades with excavated temples	417
185	Vouni. Tomb 15, Sections (1, 2); Plan with finds <i>in situ</i> (3). Tomb 16, Finds <i>in situ</i> (4); Plan (5); Section (6)	337	221	Soli. View of the excavations	417
186	Mersinaki. View of the shore, from the excavator's tent	340	222	Soli. <i>Cella</i> , Room V, of Temples A and B, from the East	421
187	Mersinaki. General view of the site. In the background, Vouni	341	223	Soli. <i>Cella</i> , Room V, of Temples A and B, from the West	421
188	The valley of Mersinaki seen from Vouni. The temple-site was situated on the shore to the left on the picture. In the bay, on the peninsula, the ancient city of Soli	343	224	Soli. Room IX, with preserved fragments of Wall 9	422
			225	Soli. Stair 159 and Altar 146	422
			226	Soli. Room XX, with row of column-bases	423
			227	Soli. South-east corner of the courtyard, Room II	423
			228	Soli. Wall 18 with superimposed Wall 27	424
			229	Soli. Stair 157 built over a rock-tomb	424
			230	Soli. Upper courtyard, Room VIII, of Temple B, from the North	429

231	Soli. Entrance into the <i>cella</i> , Room XVIII, of Temple C	431	263	Soli. General view of Temple E, from the East	477
232	Soli. Wall 52 and superimposed Wall 51	431	264	Soli. General view of Temple E, from the West	477
233	Soli. Lower courtyard of Temple B, with walls (1—4) below floor. In the foreground, Column-bases 35—37	433	265	Soli. View of the interior of Temple F, from the East. The floor of Room LIV is removed so that Walls 59—63 are visible	480
234	Soli. Cisterns 169 and 170, from the South	433	266	Soli. Western portions of Temples F (in the foreground) and E (in the background) seen from the N. E.	481
235	Soli. Room XXIII, from the North. Floor-filling partly removed in order to show Walls 58 and 57 below the floor	434	267	Soli. Analytical plan of the temples	483
236	Soli. Stratification of Room XXIII. To the left, Wall 57	434	268	Soli. Plan of Temple A (Period 1)	484
237	Soli. The joint between Walls 52 (left) and 56 (right). In the middle, Water-conduit 167	435	269	Soli. Original plan of Temples B and C (Period 2)	484
238	Soli. Room XXIV, with Water-conduit 167, from the South	435	270	Soli. Reconstructed sketch of Temple A (Period 1)	484
239	Soli. The eastern portion of Temples E (background) and F (<i>foreground</i>)	436	271	Soli. Reconstructed sketch of Temples B and C (Period 2)	484
240	Soli. Wall 79 and remains of Stair 163	436	272	Soli. Altered plan of Temples B and C (Period 4 ?)	485
241	Soli. Walls 88 and 68 from the South	438	273	Soli. Plan of Temple D (Period 2)	485
242	Soli. Remains of Stair 164 of Temple D and Wall 103 (to the right) of Temple E. In the background, Walls 105 and 106	438	274	Soli. Reconstructed sketch of Temples B and C with subsequent alterations (Period 4 ?)	485
243	Soli. Wall 80 from the East, and corner of Altar 153 of Temple D, superimposed by Wall 108 of Temple E	439	275	Soli. Reconstructed sketch of Temple D (Period 2)	485
244	Soli. Room XLII of Temple E, built above Wall 84 of Temple D	439	276	Soli. Original plan of Temple E (Period 3)	486
245	Soli. Room XXXV with Altar 155 in the rear	440	277	Soli. Plan of Temples E and F as in Period 4	486
246	Soli. Altar 150	440	278	Soli. Reconstructed sketch of Temple E (Period 3)	486
247	Soli. Remains of Wall 82 preserved at the joint between Wall 92 and 123, from N. W.	442	279	Soli. Reconstructed sketch of Temples E and F as in Period 4	486
248	Soli. Stratification close to the north façade of Wall 85, below the floor of Room XLV	442	280	Soli. Sections of pottery sherds	511
249	Soli. The courtyard (Room XLIII A) of Temple E, with floor-stratum removed so that remains of Altars 152 and 153 are visible, from the West	445	281	Soli. Room V, finds <i>in situ</i>	533
250	Soli. Walls 100—102, from the N. W.	447	282	Soli. Room V, finds <i>in situ</i>	533
251	Soli. Stratification above Walls 75 and 99	448	283	Soli. Stair 159 with finds <i>in situ</i>	534
252	Soli. Room XL built over by Wall 89	448	284	Soli. Altar 156 with finds <i>in situ</i>	534
253	Soli. Doorway through Wall 125 into Temple F	451	285	Soli. Glass bottles (Nos. 430—436) <i>in situ</i> , below Altar 197	535
254	Soli. Inner west corner of Temple F	451	286	Soli. Lamps <i>in situ</i> in Room XXV	535
255	Soli. Wall 123, eastern façade	452	287	Soli. Statuette (No. 339) re-used as a building-stone in Wall 99	536
256	Soli. Cistern 172 from the East	452	288	Soli. Sculptures (Nos. 533—536) in the earth-filling below the floor of Room LIV	536
257	Soli. Offering pit of Altar 154, visible as a dark patch in the earth. The upper edge of the pit marks the floor-level of Room XLIII A	455	289	Soli. The auditorium of the theatre before excavation	548
258	Soli. Seeds of <i>Pinus Pinaea</i> in the offering pit of Altar 154	455	290	Soli. The theatre. The eastern diazoma entrance with rock-cut channels for Walls 13 (left) and 14 (right)	549
259	Soli. Interior of Temple F, west portion from the South	457	291	Soli. The theatre. The western diazoma entrance with the rock-cut channel for Wall 17	549
260	Soli. Western portion of Temples B and C, seen from the North	473	292	Soli. The theatre. Rubble structures inside the S. E. part of Wall 16. The filling of earth and gravel supporting the seats in this part of the auditorium was enclosed by these structures	551
261	Soli. Temple C from the South. Walls 10 and 53 uncovered below the floor of Room XVI	473	293	Soli. The theatre. Detail of the rock-cut rows of seats in the centre of the auditorium	551
262	Soli. In front, Stair 161 leading to the courtyard, Room XVI; above, Stair 162 leading to the <i>cella</i> of Temple C. To the right, the <i>cella</i> of Temple B	476	294	Soli. The theatre. The western paraskenion ramp (left) and the western parodos (right)	552
			295	Soli. The theatre. The staircase of the eastern paraskenion ramp, seen from the East	552
			296	Soli. The theatre. The eastern staircase from the orchestra to the proskenion	553
			297	Soli. The theatre. The diazoma	553

- 298 Soli. The theatre from the East. Walls 6, 11, and 12 in the foreground; the auditorium in the background (left) and part of the stage-building (right) 554
- 299 Soli. The theatre. Rooms I—IV in the foreground; in the background: the stage-building (right) and part of the auditorium (left) 55b
- 300 Soli. The theatre. The proskenion seen from the orchestra 557
- 301 Soli. The theatre from the West 564
- 302 Soli. The theatre from the N. W. 565
- 303 Soli. The theatre. The stage-building with the subterranean passage in the foreground; the auditorium in the background 566
- 304 Soli. The theatre. View of the stage-building from the top of the auditorium 567
- 305 Soli. The theatre seen from the top of the auditorium towards the East 569
- 306 Soli. The theatre seen from the top of the auditorium towards the N. E. 569
- 307 Soli. The theatre. Pieces of columns *in situ*, at the E. part of the front wall of the proskenion 570
- 308 Soli. The theatre. Detail of Wall 6, with a large, reused block, possibly belonging to an architrave 570
- 309 Soli. The theatre. Section of the debris on the orchestra in front of the proskenion 571
- 310 Soli. The theatre. Section of the debris on the orchestra and the western part of the auditorium 571
- 311 Soli. The theatre. Analytical plan 572
- 312 Soli. The theatre. Reconstructed plan of the stage-building 573
- 313 Arsos. Plan of the excavations in 1917 (after a sketch kept in the Cyprus Museum and drawn by Mr. Markides) 584
- 314 Inscription (No. 20) on handle of amphora, Enkomi, T. 7 A, No. 1 607
- 315 Inscription (No. 21) on handle, Idalion, No. 1416 607
- 316—317 Inscriptions (No. 10) on handles of stirrup-vase. Enkomi, T. 18. Side-chamber, No. 55 611
- 318 Inscription (No. 12) on bottom of amphora, Enkomi, T. 18. Side-chamber, No. 47 614
- 319 Inscription (No. 3b) on bottom of amphora, Enkomi, T. 18. Side-chamber, No. 6 614
- 320 Inscription (No. 11) on handle of jug, Enkomi, T. 18. Side-chamber, No. 74 615
- 321 Inscription (No. 15) on bottom of amphora, Enkomi, T. 3, No. 272 615
- 322 Inscription (No. 17) on handle of jar, Enkomi, T. 11, No. 24 616
- 323 Inscription (p. 612) on handle from Idalion. The inscriptions are made in the wet clay, before the baking 616
- 324 Phoenician inscriptions, Vouni, T. 4, No. 3 (1); Vouni, T. 15, No. 2 (2) 620
- 325 Inscriptions Nos. 1—9 of Appendix IV 635
- 326 Skouriotissa. Ancient slag heap on the slope of the Foukassa Hill 640
- 327 Skouriotissa. Fragments of amphora used for carrying water from the ancient mine 641
- 328 Mathiati. Fragments of bronze ingot smelted to a shape suitable for transport 641
- 329 Skouriotissa. Blocks of "Roman" slag, each a single pour for smelting furnaces 642
- 330 Skouriotissa. Crystal of *selinite*, 8 inches long, from open underground mine 642
- 331—332 Mavrovouni. Ancient underground galleries with timber supports 651
- 333 Outside view of ancient square crib-timbered vertical shaft 652
- 334 Mavrovouni. Ancient untimbered gallery 652
- 335 Upper ends of four types of ancient post supports 653
- 336 Types of posts showing "horns" which prevented capping timber from sliding off 653
- 337 Mavrovouni. Ancient open stope 654
- 338 End portions of used (left) and unused (right) ancient timber caps placed horizontally on posts 654
- 339 Ancient timber, distorted by pressure from above 654
- 340—341 Set of ancient timber consisting of two upright (posts), cross piece (cap), and planks (lagging) above cap and outside of posts 655
- 342 Ancient wedges 655
- 343 Ancient wedges 656
- 344 Position of ancient crib-timbered shaft 656
- 345 Method of shaping ancient crib-timbers 656
- 346 Method of shaping ancient crib-timbers 657
- 347—348 Mavrovouni. Ancient ladders 657
- 349—351 Ancient ladder (detail), and ancient hand windlass 658
- 352 Fragments of ancient rope 659
- 353 V-shaped wooden trough 659
- 354 Round dowel pin hole 659
- 355—357 Rectangular dowel pins and holes 660
- 358 Wood tools 660
- 359 Stone probably used as base for timber post 660
- 360 Remnants of basket and slab of copper 661
- 361 Pieces of stone and pottery with slag accretions 661
- 362 Fragments of stone tools 661
- 363—364 Skouriotissa. Fragments of woven reed basket 662
- 365 Well preserved iron moil 662
- 366 Iron hoe partially corroded 662
- 367 Fragments of clay pipe found in ancient working 662
- 368—369 Skouriotissa. Views of large dump of broken pottery outside ancient mine 663
- 370 Polished cross section of wood found in ancient mine workings, showing metallic copper which has been deposited during the centuries the wood lay buried 664
- 371—372 Ancient mine timber 664
- 373 Skouriotissa. View from Foukassa Hill, showing "Pre-Roman" slag (foreground) and part of "Roman" slag (right centre) 664
- 374 Mathiati. Various tools recently found in what might have been the site of a workshop 665

375	Map of Cyprus with mining centres indicated . . .	665	380	Mavrovouni. Plan and elevations of ancient workings	668
376	Skouriotissa. Plan of orebody with ancient underground working pottery dump	666	381	Mavrovouni. Plan and cross section of ancient stairway gallery on 314 ft. level	669
377	Skouriotissa. Plan of orebody with ancient underground workings	667	382	Mavrovouni. Plan and elevations of ancient workings on 400 ft. level	670
378	Skouriotissa. Plan and section of ancient incline and ancient drift	667	383	Details of antique timber sets	670
379	Mavrovouni. Plan of orebody with ancient slag piles	668	384	Details of timber post set and timber	670
			385	Cross sections of various ancient galleries	670

L I S T O F P L A N S

- PLAN I.
Kition. Field plan.
- PLAN II.
Kition. Architectural plan.
- PLAN III.
Kition. Section I.
- PLAN IV.
Kition. Section II.
- PLAN V.
1. Kition. Section III.
2. Kition. Section IV.
3. Kition. Section V.
4. Kition. Section VI.
- PLAN VI.
1. Kition. Section VII.
2. Kition. Section VIII.
3. Kition. Section IX.
4. Kition. Section X.
- PLAN VII.
Vouni. Field plan.
- PLAN VIII.
Vouni. the temple of Athena. Architectural plan.
- PLAN IX.
Vouni. The palace. Architectural plan.
- PLAN X.
1. Vouni. The palace. Section I.
2. Vouni. The palace. Section II.
3. Vouni. The palace. Section III.
4. Vouni. The palace. Section IV.
5. Vouni. The palace. Section V.
6. Vouni. The palace. Section VI.
7. Vouni. The palace. Section VII.
8. Vouni. The palace. Section VIII.
- PLAN XI.
1. Vouni. The palace. Section IX.
2. Vouni. The palace. Section X.
3. Vouni. The palace. Section XI.
4. Vouni. The palace. Section XII.
5. Vouni. The palace. Section XIII.
6. Vouni. The palace. Section XIV A—B.
- PLAN XII.
1. Vouni. The palace. Section XIV C.
2. Vouni. The palace. Section XV A.
3. Vouni. The palace. Section XV B.
4. Vouni. The palace. Section XVI.
- PLAN XIII.
1. Vouni. The palace. Section XVII.
2. Vouni. The palace. Section XVIII.
3. Vouni. The palace. Section XIX.
4. Vouni. The palace. Section XX.
5. Vouni. The palace. Section XXI.
- PLAN XIV.
1. Vouni. The palace. Section XXII.
2. Vouni. The palace. Section XXIII.
3. Vouni. The palace. Section XXIV.
4. Vouni. The palace. Section XXV.
5. Vouni. The palace. Section XXVI.
- PLAN XV.
1. Vouni. The palace. Section XXVII.
2. Vouni. The palace. Section XXVIII.
3. Vouni. The palace. Section XXIX.
4. Vouni. The palace. Section XXX.
- PLAN XVI.
Vouni. The palace. Façades of Rooms 10—14.
- PLAN XVII.
Vouni. The palace. Façades of Rooms 10—14 (Wall 18);
17—31; 42.

PLAN XVIII.

Vouni. The palace. Façades of Rooms 43—45.

PLAN XIX.

Vouni. The palace. Façades of Rooms 46 and 55.

PLAN XX.

Vouni. The palace. Façades of Rooms 78, 80, 82, 83 and 84.

PLAN XXI.

Vouni. The palace. Façades of Rooms 86—87.

PLAN XXII.

Vouni. The palace. Façades of Rooms 88 and 92.

PLAN XXIII.

Vouni. The palace. Façades of Rooms 93, 126—128.

PLAN XXIV.

Vouni. Reconstructed sketch of the palace as in Period 1.

PLAN XXV.

Vouni. Reconstructed sketch of the palace as in Period 4.

PLAN XXVI.

Vouni. The palace. Finds *in situ*, Rooms 122—123.

PLAN XXVII.

Vouni. The palace. Finds *in situ*, Rooms 124, 129, East deposit.

PLAN XXVIII.

Vouni. Paradisotissa. Architectural plan and section.

PLAN XXIX.

Mersinaki. General plan.

PLAN XXX.

1. Mersinaki. Section I.
2. Mersinaki. Section II.
3. Mersinaki. Section III.

PLAN XXXI.

1. Mersinaki. Section IV.
2. Mersinaki. Section V.
3. Mersinaki. Section VI.
4. Mersinaki. Section VII.

PLAN XXXII.

1. Mersinaki. Section VIII.
2. Mersinaki. Section IX.
3. Mersinaki. Finds *in situ*, Pit IV.
4. Mersinaki. Finds *in situ*, Pit V.

PLAN XXXIII.

Soli. Field plan.

PLAN XXXIV.

Soli. The temples at Cholades. Architectural plan.

PLAN XXXV.

1. Soli. The temples at Cholades. Section I.
2. Soli. The temples at Cholades. Section II.
3. Soli. The temples at Cholades. Section III.
4. Soli. The temples at Cholades. Section IV.
5. Soli. The temples at Cholades. Section V.

PLAN XXXVI.

1. Soli. The temples at Cholades. Section VI.
2. Soli. The temples at Cholades. Section VII.
3. Soli. The temples at Cholades. Section VIII.
4. Soli. The temples at Cholades. Section IX.
5. Soli. The temples at Cholades. Section X.
6. Soli. The temples at Cholades. Section XI.

PLAN XXXVII.

1. Soli. The temples at Cholades. Section XII.
2. Soli. The temples at Cholades. Section XIII.
3. Soli. The temples at Cholades. Section XIV.
4. Soli. The temples at Cholades. Section XV.
5. Soli. The temples at Cholades. Section XVI.
6. Soli. The temples at Cholades. Section XVII.

PLAN XXXVIII.

Soli. The temples at Cholades. Finds *in situ*, Room V.

PLAN XXXIX.

1. Soli. The temples at Cholades. Deposit of lamps in Room XXV.
2. Soli. The temples at Cholades. Finds in Room XXXIV.
3. Soli. The temples at Cholades. Finds below Room LIV.
4. Soli. The temples at Cholades. Finds on Altar 156.
5. Soli. The temples at Cholades. Mural painting on Wall 23.
6. Soli. The temples at Cholades. Façade of Altar 155.

PLAN XL.

Soli. The theatre. Architectural plan.

PLAN XLI.

1. Soli. The theatre. Section I.
2. Soli. The theatre. Section II.
3. Soli. The theatre. Section III.
4. Soli. The theatre. Section IV.
5. Soli. The theatre. Section V.
6. Soli. The theatre. Section VI.

L I S T O F P L A T E S

PL. I.

Terracotta sculpture (Mersinaki 767, etc.).

PL. II.

Terracotta sculpture (Mersinaki 768, etc.).

PL. III.

Bronze sculptures (Vouni 152, Vouni 150).

PL. IV.

Gold bracelets (Vouni 292 g, f, e).

PL. V.

Kition. Limestone sculptures, Style I A.

PL. VI.

Kition. Limestone sculptures, Style I B.

PL. VII.

Kition. Limestone sculpture, Style II A.

PL. VIII.

Kition. Limestone sculpture, Style II A.

PL. IX.

Kition. Limestone sculptures, Style II A.

PL. X.

Kition. Limestone sculptures, Style II A.

PL. XI.

Kition. Limestone sculptures, Style II B.

PL. XII.

Kition. Limestone sculptures, Style II B.

PL. XIII.

Kition. Limestone sculptures, Style I (1—3); Style II (4—6).

PL. XIV.

Kition. Limestone sculpture, Style III A.

PL. XV.

Kition. Limestone sculptures, Style III A.

PL. XVI.

Kition. Limestone sculptures, Style III A.

PL. XVII.

Kition. Limestone sculptures, Style III A.

PL. XVIII.

Kition. Limestone sculptures, Style III A.

PL. XIX.

Kition. Limestone sculptures, Style III A.

PL. XX.

Kition. Limestone sculptures, Style III A.

PL. XXI.

Kition. Limestone sculptures, Style III A.

PL. XXII.

Kition. Limestone sculpture, Style III B.

PL. XXIII.

Kition. Limestone sculptures, Style III B.

PL. XXIV.

Kition. Limestone sculptures, Style III B.

PL. XXV.

Kition. Limestone sculptures, Style III B.

PL. XXVI.

Kition. Limestone sculptures, Style III B.

PL. XXVII.

Kition. Limestone sculptures, Style III.

PL. XXVIII.

Kition. Limestone sculpture, Style IV A.

PL. XXIX.

Kition. Limestone sculptures, Style IV A.

PL. XXX.

Kition. Limestone sculptures, Style IV A.

PL. XXXI.

Kition. Limestone sculptures, Style IV A.

PL. XXXII.

Kition. Limestone sculptures, Style IV A (1—4); Style IV B (5—7).

PL. XXXIII.

Kition. Limestone sculptures, Style IV B (1—4); Style IV (5—6).

PL. XXXIV.

Kition. Limestone sculptures, Style IV.

XVIII

PL. XXXV.

Kition. Limestone sculptures, Style V.

PL. XXXVI.

Kition. Limestone sculptures, Style V (1—2), Style VI (3—5).

PL. XXXVII.

1: Bichrome III Ware; 2, 3: Plain White VII Ware; 4: Plain White Hellenistic Ware; 5: Black Lustrous I Ware; 6: Black Lustrous II Ware; 7, 8: Red Lustrous II Ware; 9: Mat Black Ware.

PL. XXXVIII.

Kition. Objects of iron (1—2), bronze (3—9), lead (11), and terracotta (10). Terracotta lamps (12—19).

PL. XXXIX.

Kition. Objects of faience (1), steatite (2—3), glass (4—6), and ivory (7—8). Bronze coins (9—14).

PL. XL

Vouni. Limestone sculpture (from a cast).

PL. XLI.

Vouni. Limestone sculptures (1—5). Terracotta figurines (6—9).

PL. XLII.

Vouni. Bronze sculptures.

PL. XLIII.

Vouni. Bronze sculpture.

PL. XLIV.

Vouni. Bronze sculpture (1—2). Objects of iron (3—6).

PL. XLV.

Vouni. Bronze. 1—3: Spear-heads; 4: Arrows; 5—16: Arrow-heads; 17: Pike; 18: Strigil; 19: Chisel; 20—22: Nails; 23—24: Rivets.

PL. XLVI.

Vouni. Bronze. 1: Bracelet; 2: Fish-hook; 3: Ring; 4, 19: Ladles; 5, 7: Rods; 8: Loop; 9: Cylinder; 10: Disc; 12—13: Pins; 6, 14—16, 20—21: Mountings; 11, 17, 24: Sheets; 22—23: Bowls; 18: Indeterminable tool.

PL. XLVII.

Vouni. Objects of silver (1—2), gold (3—6), stone (7—9), and terracotta (10,14). Silver coins (11—12). Marble bowl (13).

PL. XLVIII.

Vouni. Limestone sculpture, Style I.

PL. XLIX.

Vouni. Limestone sculptures, Style I.

PL. L.

Vouni. Limestone sculpture, Style II A.

PL. LI.

Vouni. Limestone sculpture, Style II A.

PL. LII.

Vouni. Limestone sculpture, Style II A.

PL. LIII.

Vouni. Limestone sculptures Style, II A.

PL. LIV.

Vouni. Limestone sculptures, Style II A.

PL. LV.

Vouni. Limestone sculptures, Style II A.

PL. LVI.

Vouni. Limestone sculptures, Style II A.

PL. LVII.

Vouni. Limestone sculpture, Style II B.

PL. LVIII.

Vouni. Limestone sculptures, Style II B.

PL. LIX.

Vouni. Limestone sculptures, Style II B.

PL. LX.

Vouni. Limestone sculptures, Style II B.

PL. LXI.

Vouni. Limestone sculptures, Style II.

PL. LXII.

Vouni. Limestone sculptures, Style III A.

PL. LXIII.

Vouni. Limestone sculptures, Style III A.

PL. LXIV.

Vouni. Limestone sculptures, Style III A.

PL. LXV.

Vouni. Limestone sculptures, Style III A (1—6); Style III B (7—8).

PL. LXVI.

Vouni. Limestone sculptures, Style III B.

PL. LXVII.

Vouni. Limestone sculptures, Style III B.

PL. LXVIII.

Vouni. Limestone sculptures, Style III B.

PL. LXIX.

Vouni. Limestone sculptures, Style III B (1); Style III (2—3); Style IV (4—5)

PL. LXX.

Vouni. Terracotta sculptures, Style I (1); Style II A (2—3).

PL. LXXI.

Vouni. Terracotta sculptures, Style II A.

PL. LXXII.

Vouni. Terracotta sculpture, Style II A.

PL. LXXIII.

Vouni. Terracotta sculptures, Style II A (1—2); Style II B (3—4).

PL. LXXIV.

Vouni. Terracotta sculpture, Style III.

PL. LXXV.

Vouni. Terracotta sculpture, Style IV.

PL. LXXVI.

Vouni. Limestone sculptures. Idol (1); Animal statuettes (2—6).

PL. LXXVII.

Vouni. Terracotta sculptures. Animal statuettes (1—6); Idols and Figurines (7—14).

PL. LXXVIII.

Vouni. Terracotta sculptures. Idols and Figurines.

PL. LXXIX.

Vouni. Terracotta figurines.

PL. LXXX.

Vouni. Terracotta figurines.

PL. LXXXI.

1—3: White Painted VI Ware; 4: Plain White V—VI Ware; 5—9: Plain White VI Ware.

PL. LXXXII.

1—3: Plain White VI Ware; 4: Plain White VI—VII Ware; 5—9: Plain White VII Ware.

PL. LXXXIII.

1—9: Coarse Ware; 10—13: Black Glazed Ware.

PL. LXXXIV.

Red Figured Ware.

PL. LXXXV.

Red Figured Ware.

PL. LXXXVI.

1—2: White Grounded Ware; 3—5: Red Figured Ware.

PL. LXXXVII.

Vouni. Iron. 1: Rod; 2—3: Arrow-heads; 4: Sickle; 5: Spade; 6: Nail. Bronze. 7: Spear-head; 8—9: Arrow-heads; 10: Shovel; 11: Spatula; 12—13: Earrings; 14: Bracelet; 15: Pendant; 16: Pin; 17—20: Mountings.

PL. LXXXVIII.

Vouni. Bronze. 1—5: Mountings; 6: Nails; 7—8: Loops; 9—11: Bowls.

PL. LXXXIX.

Vouni. Bronze 1: Jug; 2: Incense-burner; 3—4: Stands; 5—7: Handles. Lead. 8: Weight. Silver. 13: Earring; 14: Pendant; 9—10, 15—17: Bracelets; 11—12: Mountings.

PL. XC.

Vouni. Silver. 1—3: Bracelets; 4—7: Bowls.

PL. XCI.

Vouni. Gold bracelets.

PL. XCII.

Vouni. Gold and silver treasure.

PL. XCIII.

Vouni. Objects of gold (1—3), terracotta (4—9, 11), faience (10, 12—13), and glass (14—15).

PL. XCIV.

Vouni. Stone. 2: Loom-weight; 3: Net-sinker; 8: Incense-burner; 6: Bowl; 1: Alabastron; 7: Stele; 5: Architectural fragment; 4: Skaraboid.

PL. XCV.

Vouni. 1: Coin of bronze; 2—5: Coins of gold; 6—15: Coins of silver.

PL. XCVI.

Vouni. Silver coins.

PL. XCVII.

Vouni. Silver coins.

PL. XCVIII.

Vouni. 1—5: Limestone sculptures; 6: Bronze plaque; 7: Antefix. 8. Vouni, Tomb 1. Objects of iron, bronze, silver, gold, and alabaster.

PL. XCIX.

Vouni. Tomb 1. Pottery.

2, 84, 26, 85

7, 77, 5, 27, 43, 20, 98, 74, 78, 11

46, 97, 93, 24, 30, 8, 76, 86, 22, 4, 14, 10, 9, 6, 13, 87, 48, 40, 47, 44, 21, 88

52, 55, 68, 51, 70, 69, 95, 90, 89, 39, 96, 73, 12, 1, 23, 3

36, 38, 32, 37, 17, 34, 50, 18, 33, 79, 35, 19, 25, 91, 16

29, 94, 53, 54, 83, 67, 49, 31, 15, 99, 71, 72, 28, 45

PL. C.

1. Vouni. Tomb 2. Pottery.

6, 7, 23, 22, 16, 21

19, 5, 9, 17, 11, 3, 14, 20, 18

10, 4, 1, 2, 12, 15, 8

2. Vouni Tomb 2. Minor objects.

PL. CI.

Vouni. Tomb 3. Pottery.

21, 1, 22, 30, 28, 9

40, 19, 32, 31, 33, 4, 14, 23, 38, 10, 18

7, 25, 41, 27, 5, 12, 13, 16, 36, 34, 3, 29, 37, 20, 35, 39, 2, 42, 26, 24, 15, 6, 11, 8

PL. CII.

1. Vouni. Tomb 3. Objects of bronze, silver, bone, and alabaster.

2. Vouni. Tomb 5. Pottery.

3. Vouni. Tomb 4. Pottery.

1, 2, 3

4. Vouini. Tomb 6. Pottery.

5, 10, 13, 11

6, 9, 12, 1, 3, 7, 2

PL. CIII.

Vouini. Tomb 7. Pottery.

47

6, 4, 21, 39, 40, 41, 3, 5,

10, 36, 34, 16, 11, 28, 46, 7, 9, 45

38, 25, 27, 8, 12, 44, 30, 17, 33, 1, 14, 13, 20, 15, 35

29, 43, 24, 31, 22, 26

PL. CIV.

Vouini. Tomb 8. Pottery.

14, 12, 20, 15, 48

9, 36, 37, 4, 18, 13, 47, 49

3, 27, 40, 8, 52, 39, 31, 5, 1, 45, 35, 11, 33, 17, 21, 38, 41

58, 2, 42, 23, 55, 51, 50, 29, 30, 10, 44, 54, 46, 43, 56

PL. CV.

1. Vouini. Tomb 7. Objects of terracotta and alabaster.

2. Vouini. Tomb 8. Objects of bronze and alabaster.

3. Vouini. Tomb 11. Objects of bronze and glass.

PL. CVI.

1. Vouini. Tomb 9. Pottery.

5, 3, 1, 4, 2

2. Vouini. Tomb 11. Pottery.

3, 22, 7, 19, 5, 21, 1

18, 4, 16, 9, 15, 17, 8, 14, 23, 24

PL. CVII.

1. Vouini. Tomb 12. Pottery.

8, 5, 4, 7, 6, 2

2. Vouini. Tomb 13. Pottery.

4, 5, 6, 21, 18, 25, 23, 22, 14, 15, 24, 1, 10

12, 9, 11, 19, 8, 16, 17, 2, 3, 7, 20, 13, 27

3. Vouini. Tomb 13. Scarab.

4. Vouini. Tomb 14. Objects of iron, bronze and alabaster.

PL. CVIII.

1. Vouini. Tomb 14. Pottery.

34, 35, 12, 13, 11, 7, 21, 5

3, 33, 10, 6, 31, 9, 24, 16, 14, 15, 27, 2, 26

30, 1, 23, 22, 20, 19, 4, 8, 17, 25, 18

2. Vouini. Tomb 15. Pottery.

7, 2, 3, 1, 6, 4

PL. CIX.

1. Vouini. Tomb 15. Bronze mirror.

2. Vouini. Tomb 16. Objects of silver.

3. Vouini. Tomb 16. Pottery.

3, 13, 6, 2, 15, 16

19, 20, 17, 18, 1, 5, 7

PL. CX.

Mersinaki. Marble relief (from a cast).

PL. CXI.

Mersinaki. Sculpture of soft limestone, Style I.

PL. CXII.

Mersinaki. Terracotta sculpture, Style I.

PL. CXIII.

Mersinaki. Terracotta sculptures, Style I.

PL. CXIV.

Mersinaki. Terracotta sculpture, Style I.

PL. CXV.

Mersinaki. Sculptures of soft limestone, Style II.

PL. CXVI.

Mersinaki. Sculptures of soft limestone, Style II.

PL. CXVII.

Mersinaki. Sculptures of soft limestone, Style II.

PL. CXVIII.

Mersinaki. Terracotta sculpture, Style II A.

PL. CXIX.

Mersinaki. Terracotta sculptures, Style II A.

PL. CXX.

Mersinaki. Terracotta sculpture, Style II A.

PL. CXXI.

Mersinaki. Terracotta sculptures, Style II A.

PL. CXXII.

Mersinaki. Terracotta sculptures, Style II A.

PL. CXXIII.

Mersinaki. Terracotta sculptures, Style II A.

PL. CXXIV.

Mersinaki. Terracotta sculpture, Style II B.

PL. CXXV.

Mersinaki. Terracotta sculptures, Style II B.

PL. CXXVI.

Mersinaki. Sculpture of soft limestone, Style III A.

PL. CXXVII.

Mersinaki. Sculptures of soft limestone, Style III A.

PL. CXXVIII.

Mersinaki. Sculptures of soft limestone, Style III A, (1—2), Style III B, (3—4) and terracotta, Style III (5—6).

PL. CXXIX.

Mersinaki. Terracotta sculptures, Style III.

PL. CXXX.

Mersinaki. Terracotta sculpture, Style III.

PL. CXXXI.

Mersinaki. Terracotta sculptures, Style III.

PL. CXXXII.

Mersinaki. Terracotta sculptures, Style III.

PL. CXXXIII.

Mersinaki. Sculptures of soft limestone, Style IV A (1—8, 10—13), and Style IV B (9).

PL. CXXXIV.

Mersinaki. Terracotta sculpture, Style IV.

PL. CXXXV.

Mersinaki. Terracotta sculptures, Style IV.

PL. CXXXVI.

Mersinaki. Terracotta sculptures, Style IV.

PL. CXXXVII.

Mersinaki. Sculpture of hard limestone, V A.

PL. CXXXVIII.

Mersinaki. Sculptures of hard limestone (1—2), and soft limestone (3—4), Style V A.

PL. CXXXIX.

Mersinaki. Sculpture of soft limestone, Style V A.

PL. CXL.

Mersinaki. Sculptures of hard limestone, Style V A.

PL. CXLI.

Mersinaki. Sculptures of hard limestone, Style V B.

PL. CXLII.

Mersinaki. Sculptures of terracotta, Style V (1—5), and hard limestone, Style VI (6—9).

PL. CXLIII.

Mersinaki. Sculptures of hard limestone, Style VI.

PL. CXLIV.

Mersinaki. Sculptures of terracotta, Style VI (1—3), and hard limestone, Style VII (4—5).

PL. CXLV.

Mersinaki. Terracotta sculptures, Style VII.

PL. CXLVI.

Mersinaki. Terracotta sculpture.

PL. CXLVII.

Mersinaki. Terracotta sculptures.

PL. CXLVIII.

Mersinaki. Sculptures of terracotta (1—2), and limestone (3—5). Inscriptions of marble and stone (6—12).

PL. CXLIX.

Mersinaki. Pottery (1—3). Objects of bronze (4—8), glass (9), faience (10), and bone (11). Terracotta lamps (12—14).
Bronze coins (15—18).

PL. CL.

Soli. Marble sculpture, Style I A.

PL. CLI.

Soli. Marble sculptures, Style I A.

PL. CLII.

Soli. Marble sculpture, Style I B.

PL. CLIII.

Soli. Marble sculpture, Style I B.

PL. CLIV.

Soli. Marble sculptures, Style I B.

PL. CLV.

Soli. Marble sculptures, Style I B.

PL. CLVI.

Soli. Marble sculpture, Style I B (1); Marble portrait of Agrippina, (2—4).

PL. CLVII.

Soli. Marble portrait of Agrippina.

PL. CLVIII.

Soli. Sculptures of soft limestone.

PL. CLIX.

Soli. Sculptures of hard limestone, Style I A.

PL. CLX.

Soli. Sculptures of hard limestone, Style I A.

PL. CLXI.

Soli. Sculptures of hard limestone, Style I B.

PL. CLXII.

Soli. Sculptures of hard limestone, Style I B.

PL. CLXIII.

Soli. Sculptures of hard limestone, Style I B.

PL. CLXIV.

Soli. Sculptures of hard limestone, Style II B.

PL. CLXV.

Soli. Sculpture of hard limestone, Style II B.

PL. CLXVI.

Soli. Sculptures of hard limestone, Style II B.

PL. CLXVII.

Soli. Sculpture of hard limestone, Style III.

PL. CLXVIII.

Soli. Sculptures of hard limestone, Style III.

PL. CLXIX.

Soli. Sculptures of hard limestone, Style III.

PL. CLXX.

Soli. Sculpture of hard limestone, Style IV.

PL. CLXXI.

Soli. Sculpture of hard limestone, Style IV.

PL. CLXXII.

Soli. Sculptures of hard limestone, Style IV.

PL. CLXXIII.

Soli. Marble sculptures (1—5); Terracotta sculptures (6—13); Marble lamp (14); Marble inscriptions (15—16).

PL. CLXXIV.

Soli. Inscriptions of marble and stone (1—3); Terracotta lamps, Type 1 (4—5), Type 2 (6), Type 3 (7), Type 4 (8), Type 5 (9—16).

PL. CLXXV.

Soli. Terracotta lamps, Type 6 (1—2), Type 7 (3), Type 8 (4—8), Type 9 (9—10).

PL. CLXXVI.

Soli. Objects of terracotta, bronze, and glass (1—8). Bronze coins (9—17).

PL. CLXXVII.

Soli. Bronze coins (1—18); Silver coin (19).

PL. CLXXVIII.

Soli. Pottery sherds.

PL. CLXXIX.

Soli. Pottery sherds.

PL. CLXXX.

Soli. Objects of bronze (1—9), lead (10—11), and terracotta (12—13). Terracotta lamps (14—16). Pottery (17—18). Limestone sculpture (19).

PL. CLXXXI.

Soli. Marble sculptures (1—2). Terracotta figurines (3—11).

PL. CLXXXII.

Soli. Terracotta figurines (1—6). Objects of bronze (7—15), lead (16), and terracotta (17—20). Terracotta lamps (21—23).

PL. CLXXXIII.

Soli. Bronze coins (1—9). Architectural fragments (10—11).

PL. CLXXXIV.

Soli. Architectural fragments.

PL. CLXXXV.

Arsos. Limestone sculpture, Style I.

PL. CLXXXVI.

Arsos. Limestone sculptures, Style I.

PL. CLXXXVII.

Arsos. Limestone sculptures, Style I (1—2); Style II (3—4).

PL. CLXXXVIII.

Arsos. Limestone sculptures, Style II.

PL. CLXXXIX.

Arsos. Limestone sculptures, Style III (1); Style IV (2—3).

PL. CXC.

Arsos. Limestone sculptures, Style IV (1—8); Style V (9—10).

PL. CXCI.

Arsos. Limestone sculptures, Style V (1—3); Style VI (4—8).

PL. CXCII.

Arsos. Limestone sculptures, Style VII.

PL. CXCIII.

Arsos. Limestone sculptures, Style VII.

PL. CXCIV.

Arsos. Limestone sculpture, Style VIII.

PL. CXCV.

Arsos. Limestone sculpture, Style VIII.

PL. CXCVI.

Arsos. Limestone sculptures, Style VIII.

PL. CXCVII.

Arsos. Limestone sculptures, Style IX.

PL. CXCVIII.

Arsos. Limestone sculptures, Style IX.

PL. CXCIX.

Arsos. Limestone sculptures, Style IX.

PL. CC.

Arsos. Limestone sculptures, Style IX.

PL. CCI.

Arsos. Limestone sculptures, Style IX.

PL. CCII.

Arsos. Terracotta sculptures. Hand-made statuettes (1—3); Moulded male statuettes (4—5); Moulded female statuettes (6—12).

PL. CCIII.

Arsos. Terracotta sculptures. Moulded female statuettes.

PL. CCIV.

Arsos. Objects of bronze (1—11), faience (12), silver (13—16), and gold (17—22). Scarabs (23).

PL. CCV.

Arsos. Gold. 1: Bowl; 2—4: Necklaces.

PL. CCVI.

Stockholm, Cyprus Collection. Limestone sculpture.

PL. CCVII.

Stockholm, Cyprus Collection. Limestone sculpture.

PL. CCVIII.

Stockholm, Cyprus Collection. Limestone sculpture.

THE SWEDISH
CYPRUS EXPEDITION

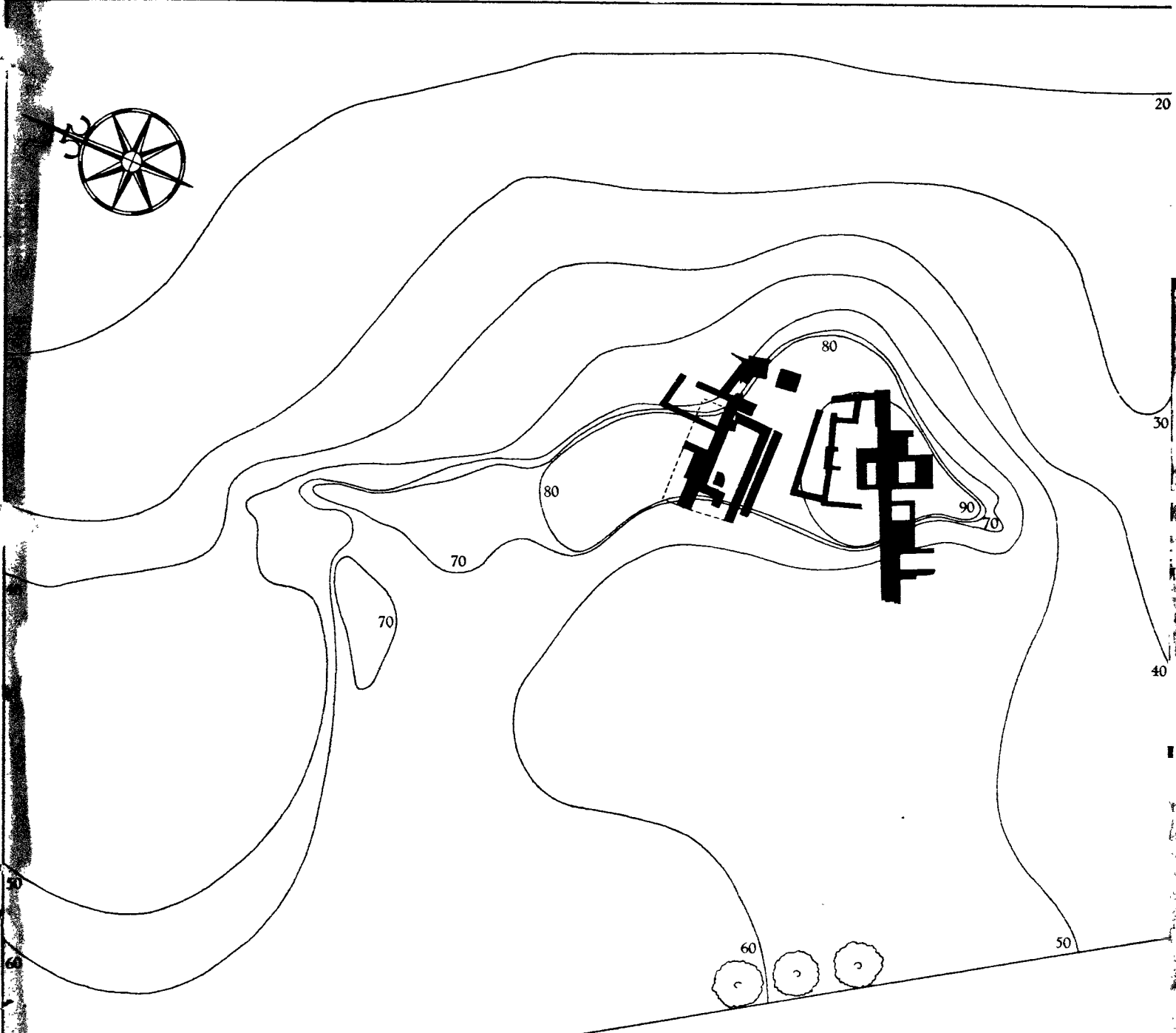

KITION
Field plan

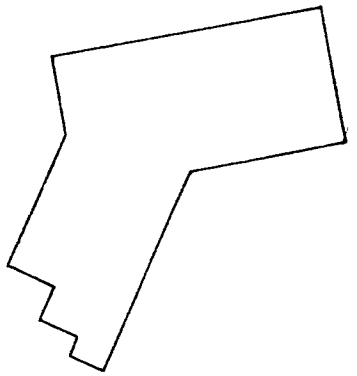

K I T I O N

INTRODUCTION (Figs. 1, 2; Plan I)

The ruins of Kition, the ancient capital of the Phoenician colony in Cyprus, are found within the boundaries of the modern town of Larnaca, on the S. coast of the island.

The topographical testimonies are collected by Oberhummer.¹

The city was surrounded by massive walls, which can still be traced to the W. In the north-eastern part of the city area a mound of debris, now called Bamboula, marks the site of the acropolis. Between the acropolis and the present sea-shore is the place of the ancient harbour, which has gradually silted up so that it formed marshy land in the 19th century. In 1879 the Government of Cyprus undertook to fill in the marsh for hygienic reasons, in order to get rid of the malaria mosquitos. For that purpose the soil for filling was taken from the upper strata of the accumulated debris of the acropolis, and in this way the present top layers, too, were much disturbed.

In the Catalogue of the Cyprus Museum pp. 5 f. there are complete references to the excavations carried out in Kition until 1894. The list given there should be augmented by including some soundings carried out in 1914 by Prof. Myres on the mound of Bamboula. No record of these soundings has been published.

Our work of excavation began in October, 1929, and continued until April, 1930, with an interruption during the winter-season. We attempted a stratigraphic examination of the Bamboula mound in order to obtain an archaeologically fixed point for the dating of the Phoenician colonization of Cyprus. Further, we wanted to study the ceramic development in order to collect archaeological material for elucidating the problem of the rôle played by the Phoenicians in the development of the Cypriote culture. For this purpose it seems difficult to find a better place of observation than the acropolis of the Phoenician capital in Cyprus.

After three days' digging, however, we encountered a large deposit of sculptures, and the excavation program was therefore enlarged by including an examination of the area within which the sculptures were found.



Fig. 1. Kition. The Acropolis seen from the South.

ARCHITECTURE (Figs. 3—22; Plans II—VI)

ARCHITECTURAL ELEMENTS (FIGS. 3—11, 19—22; PLAN II)

W a l l s.

*Walls 1—2.**

Width: 0.60 m. Height: 0.80 m.

These walls are built of rubble of medium size without any binding material. The faces are carefully laid. The stones are, as a rule, of approximately equal size, but larger stones occur here and there. Between the facing stones, there is an inner core of smaller rubble. At the W. end of Wall 1, a rectangular limestone block rests on top of the wall along its N. face. This may have served as substructure for a threshold. The upper walls were built of mud-bricks, as can be seen from mud-brick remains on top of the stone foundations (cf. Section VI, p. 13). This shows that the stone foundations are preserved in their original height. The walls are bonded to each other and are founded on the rock. Wall 1 was excavated for a length of 2.50 m., but of Wall 2 only a short piece was laid bare.

* The numbers of the walls are indicated on the plans. Figs. 15—18.



Fig. 2. Kition. The Acropolis seen from the East.

Walls 3—6.

Width: 0.45—0.60 m. Height: 0.50 m.

The material of these walls consists of rubble mixed with a few blocks of sandstone. The stones are of varying size, small and larger stones being used without distinction and the masonry is less regular than in Walls 1—2, and the faces are not strictly straight. Sometimes, the stones of the opposite faces meet each other in the middle of the wall. Sometimes, where they are of smaller size, there is a core of rubble in the middle. The walls are not bonded to each other and are founded in the debris at level 57.5 — 60.0. Wall 6 is much destroyed, and parts of the N. face of Wall 3 are damaged, and a piece of its E. part is entirely missing.

Walls 7—8 A.

Width: 1.00—1.20 m. Height: 0.25—0.30 m.

These walls consist of a single course of large, rectangular blocks of sandstone of the same kind as that quarried nowadays at Ajia Paraskevi outside Nicosia. The blocks are sometimes placed transversely covering the whole width of the wall, sometimes the one face of the wall is built of blocks placed lengthways and the opposite face of transverse blocks, and sometimes it is built of three blocks placed lengthways side by side. The S. part of the



Fig. 3. Kition. In the foreground: Altar 36, Walls 3, 8 A—B, and 9; in the background: Walls 3 and 4.



Fig. 4. Kition. Walls 7 A—B to the right; Altar 36 and the base of the cult-statue (No. 560) in the background.

blocks in Wall 8 A are cut concave, apparently in connexion with the later digging of a pit in this place for burying waste *ex votis* (cf. pp. 11, 21 f., 23 f., 65). In the E. face of Wall 7 A, the rectangular base of a large stone statue has been built in. The E. part of the base projects out of the face of the wall. The statue itself was missing and only the feet were preserved (cf. p. 64). The walls are founded in the debris at about levels 62.5—63.5.

Walls 7—8 B.

Width: 0.60—0.75 m. Height: 0.25—0.40 m.

These walls are built on top of the preceding walls, but do not cover their entire width. Wall 7 B runs somewhat inside the E. face of wall 7 A and Wall 8 B along the N. face of Wall 8 A. The material of the walls consists of the same kind of sandstone as in the preceding walls mixed with occasional pieces of limestone. The blocks are of a smaller size and not so well cut as those of Walls 7—8 A, and the masonry is of an irregular construction, the blocks being rather piled up than joined together.

Wall 9.

Width: 0.65 m. Height: 0.40 m.

This wall is built of the same material and shows the same construction as Walls 7—8 B. It is an angular continuation of Wall 8 B to the N. but the junction is missing.

Walls 10—16.

Width: 0.35—0.55 m. Height: 0.60 m.

These walls form a structural unit; they are built of the same material and show the same construction. The walls consist of two courses of stone, the lowermost being rubble, and the top course consisting of covering, rectangular blocks of sandstone. The top course is missing to a great extent. The rubble stones are of varying sizes; when the edging stones are large they meet in the middle of the wall; when they are of smaller size, the interval is filled with small rubble. Walls 14 and 15, 12 and 14 are properly bonded to each other.

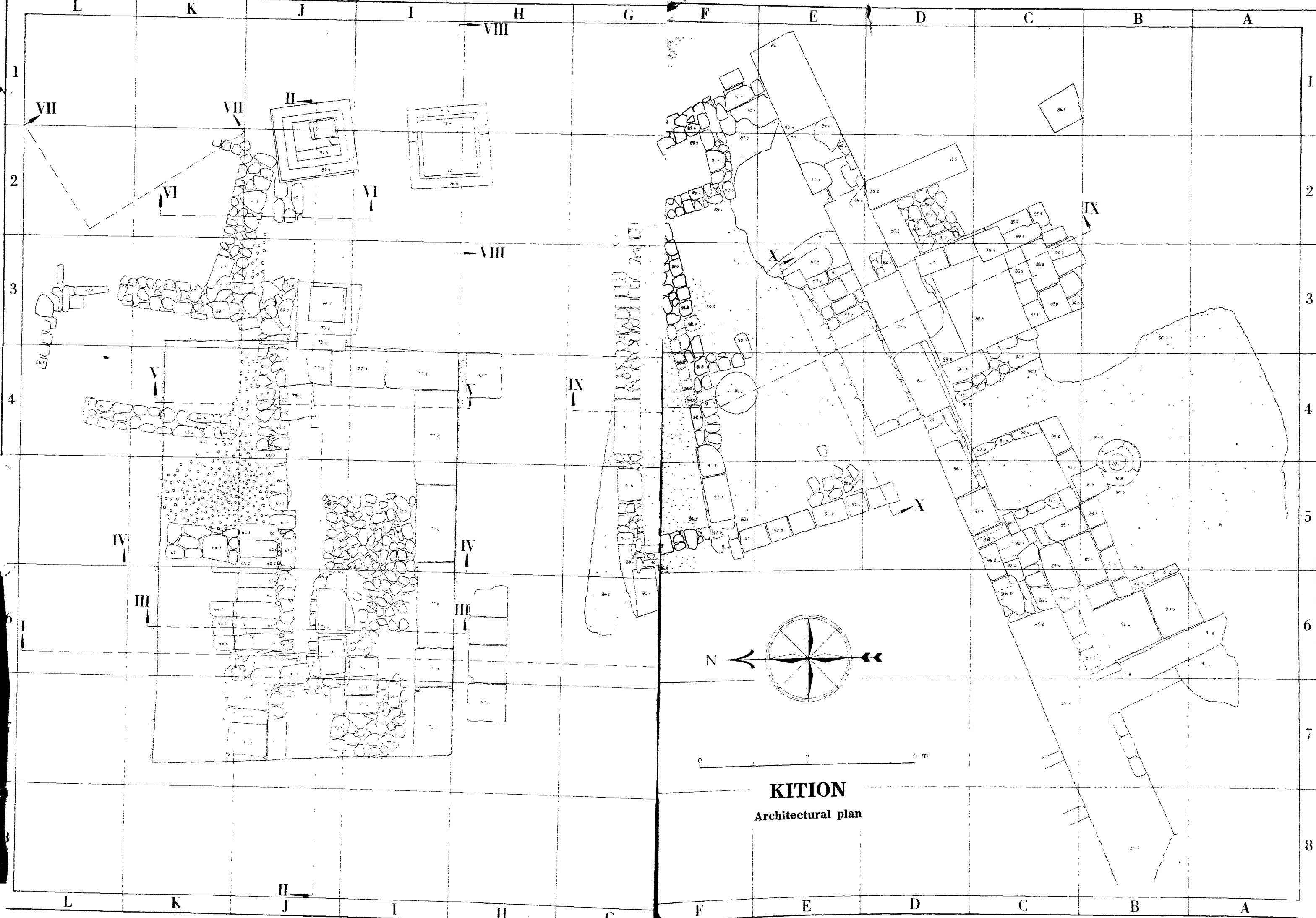

KITION
Architectural plan

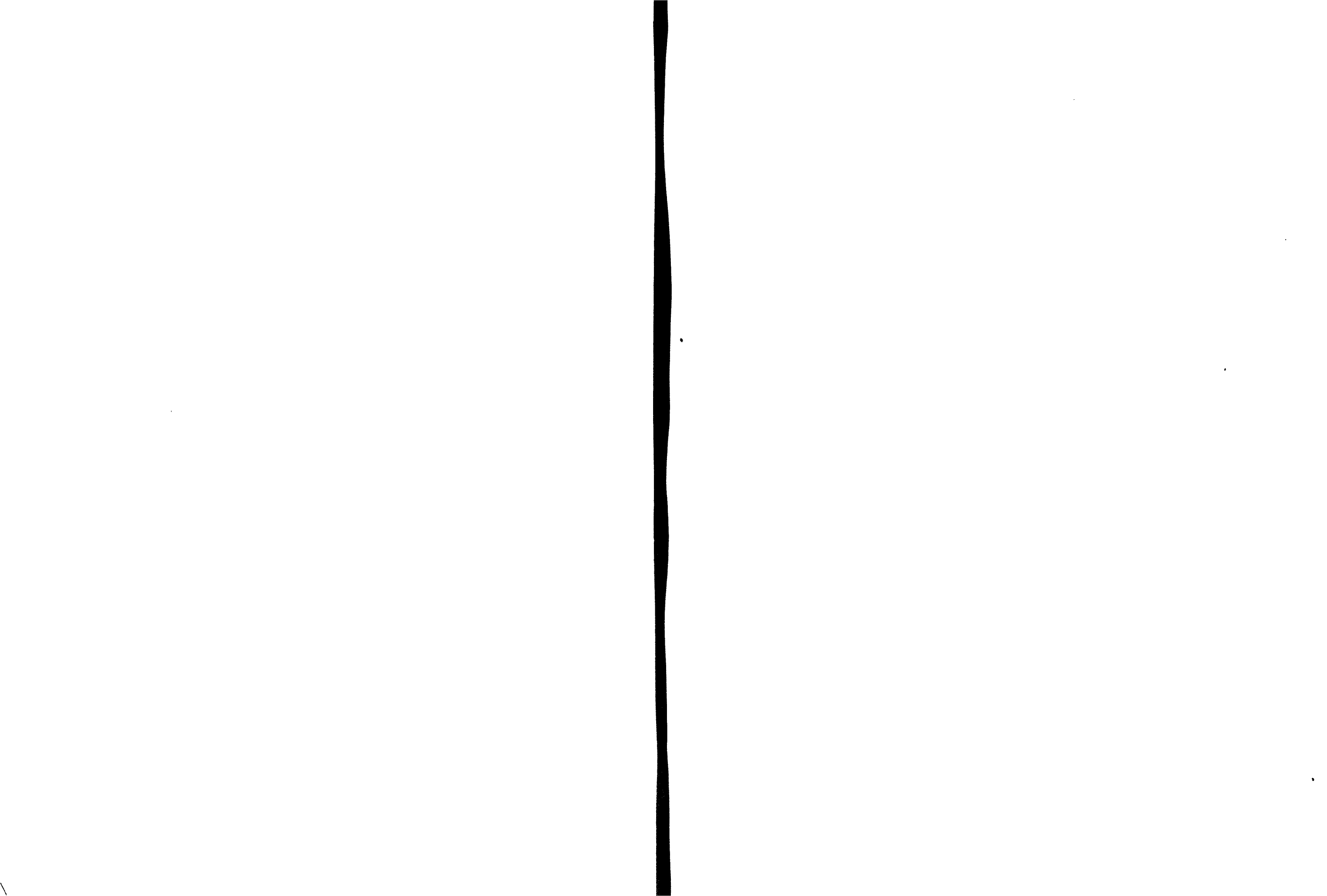



Fig. 5. Kition. Walls 23 B, 28—33 in the foreground;
Walls 17—19 and Altar 40 in the background.



Fig. 6. Kition. Walls 23 A and B.

The other adjoining walls are only loosely, or not at all, bonded. The walls are founded in the debris at about level 86.0.

Walls 17—19.

Width: 0.20 m. Height: 0.80 m.

These walls are built of superimposed, orthostatic blocks with only a single row of blocks in each course. Up to three courses are preserved. The walls are founded partly on top of Wall 12 and partly in the debris at about level 91.0.

Wall 20.

Width: 0.65 m. Height: 1.30 m.

This wall is built of roughly cut stones of medium size and rubble in distinctly stratified courses. The faces are carefully laid and the stones usually meet in the middle of the wall. The wall is founded in the debris at level 74.5—75.0.

Walls 21—22.

Width: 1.05 m. Height: 0.60 m.

These are short cross walls between Walls 20 and 23 A. They are built of orthostatic limestone blocks forming a double shell with a filling of earth, lime-mortar, and stones in between. The shells consist both of single and double rows of orthostates and the blocks are joined with lime-mortar. The walls are not properly bonded to any of the adjoining walls and are founded in the debris at about level 74.0—74.5. Up to three courses of blocks are preserved.

Walls 23 A—B.

Width: (A)	1.25 m.	Height: (A)	2.00 m.
	(B) 0.65—1.30 m.	(B)	1.40 m.

Wall 23 A is a wide, solid wall, running in S. W. — N. E. direction across the whole area excavated. It is built on a foundation of large, undressed blocks of rock, partly revetted by rubble, and founded at level 64.0—65.0. This foundation is covered by a levelling of large, rectangular slabs on which the wall was built. The wall has, however, been entirely



Fig. 11. Kition. Floor of Type 3 at level 66.5 in Square K 4.



Fig. 12. Kition. Part of Section I with slabs of Platform 35.

the uppermost 0.55 m. from the base, and 0.38 m. from the top. The pillar stands on a rectangular limestone slab, and is founded in the debris at level 75.7.

Altar 39. Length: 1.10 m. Width: 0.95 m. Height: 0.55 m.

The altar is built of rectangular limestone blocks without any binding material. It is a step-shaped structure with a base built of two courses of horizontal blocks placed lengthways; this base supports a course of orthostates, another course of horizontal blocks placed lengthways, and a top structure of orthostatic blocks. On account of the step-shaped construction of the altar, the top measures only 0.80 m. 0.70 m., while the base measures 1.50 m. 1.35 m., and the whole construction is 1.15 m. high. The altar is founded in the debris at level 80.0. Parts of the top blocks are missing.

Altar 40. Length: 1.15 m. Width: 1.15 m. Height: 0.60 m.

This altar consists of a square limestone monolith with moulded base, resting on a substructure of rectangular limestone slabs joining each other without any binding material. This substructure included, the altar measures 1.45 m. 1.45 m. 1.05 m.

Floors.

Six structural types of floors are represented.

1. Floor of rammed earth. A single representative of this type of floor is found at level 46.5.

KITION

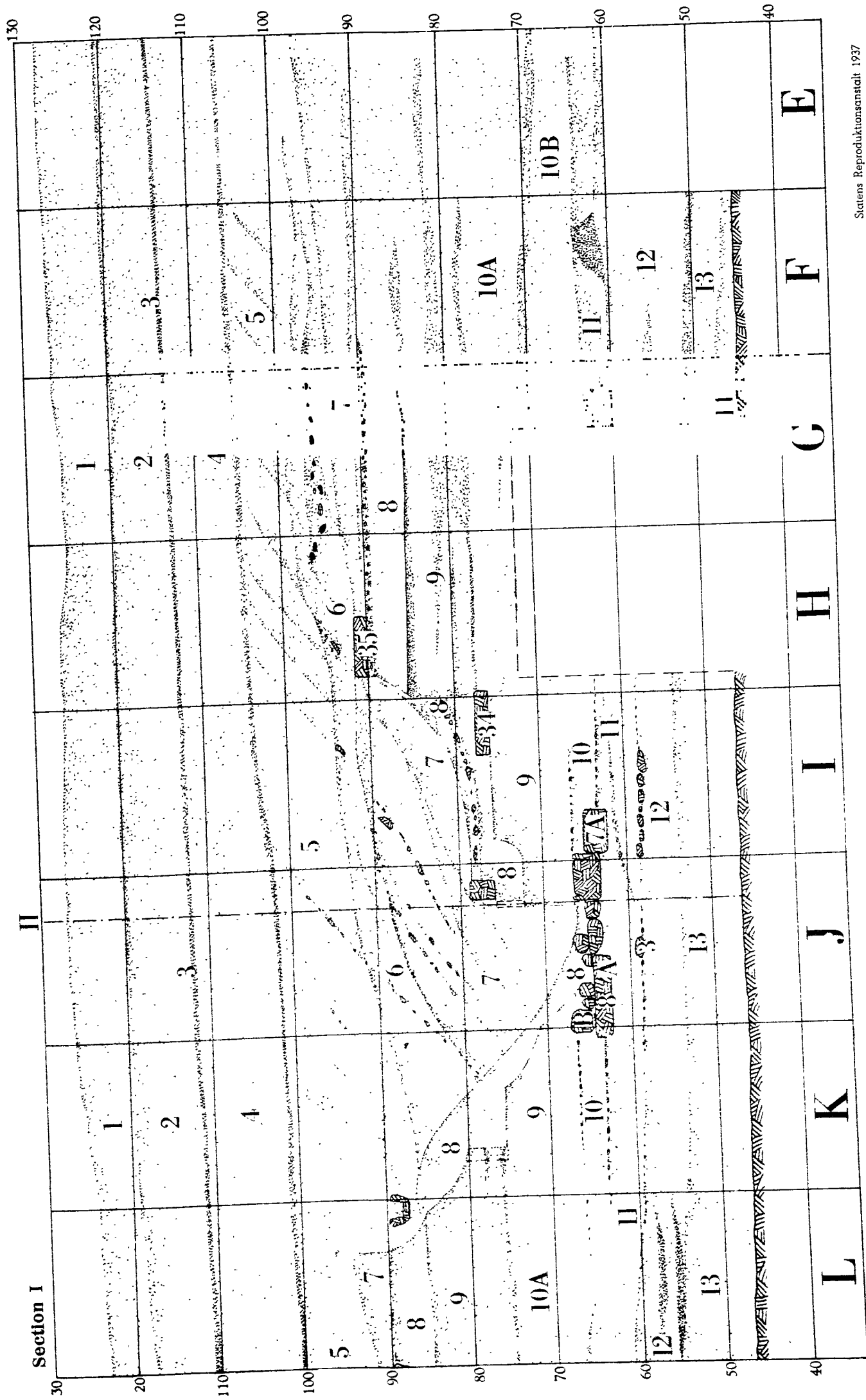

2. Floor of small pebbles, sometimes resting on a substructure of rubble. A floor of this type is found at level 50.5—53.5; another floor of the same type appears at level 58.5—59.5; a third floor of this type is represented at level 63.5. The floor at level 58.5—59.5 rests partly on a substructure of rubble, to the S. of Wall 3. To the N. of this wall, however, the same floor appears without such a substructure.
3. Floor of buff sand and gravel partly covered with thin limestone slabs. A floor of this type is represented at level 66.5. Pieces of limestone slabs are preserved in Square K 4.
4. Floor of sand and lime-concrete, sometimes covered with limestone slabs. A floor of this type is found at level 75.5—77.5; another floor of the same type occurs at about level 86.0. This second floor is partly covered with limestone slabs, which are preserved in Squares C—D:2—3.
5. Floor of lime-cement. Floors of this type are represented at level 89.0—91.5.
6. Floor of brown earth-concrete. There is a single representative of this type of floor, at about level 93.5.

STRATIFICATION (FIGS. 12—14; PLANS III—VI)

Description of the layers.

Section I (Figs. 12—14; Plan III).

This section runs in a south-northerly direction, from Square E 6 to L 6. The section is divided into three stratigraphic parts, the first (A) covering Squares E—H, the second (B) Squares I—J and 1.40 m. within Square K, the third (C) covering the remaining part of the section.

Section I A shows the following stratification.

1. Surface earth of greyish clay and rather hard consistency.
2. Layer of mixed debris of reddish earth.
3. Layer of buff-brown sand.
4. Layer of grey, clayey culture earth with remains of carbonized matter. Towards the bottom of the layer, it merges into a line of dark earth marking a trodden surface.
5. Building debris with oblique streaks of mud-brick earth, lime-mortar, gravel, and chips of stone.
6. Building debris of similar consistency and oblique direction, but mixed with large pieces of lime-concrete and with only sparse chips of stone, the earth consisting of more homogeneous mud-brick remains.
7. Horizontal layer of earth, brown in colour, mixed with sparse, architectural remains resting on a levelling debris of earth marking the level of a floor which is not well preserved in this section, but appears in Section IX—X at about level 89.0 (cf. p. 14).
8. Layer of dark, clayey culture earth, resting on a floor of lime-concrete.
9. Layer of dark, clayey culture earth, interrupted by alluvial streaks of sand and gravel, and resting on a floor of sand and lime-concrete.

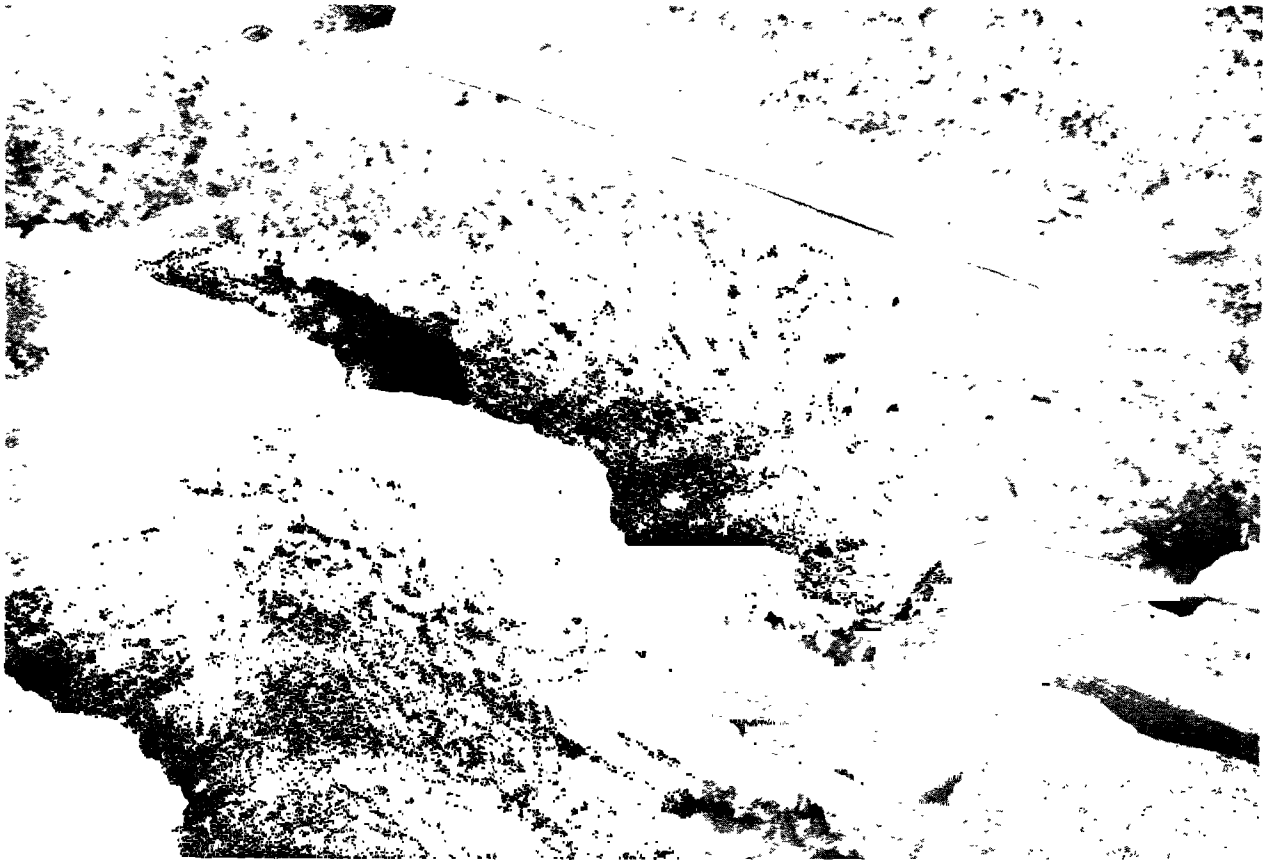

Fig. 13. Kition. Section I B, with slabs of Platform 35 to the right.

10. Layer of sandy earth, greenish-brown in colour, and clayey earth, interrupted by a streak of sand, dividing it into two parts called 10 A and B.
11. Layer of dark, clayey earth, interrupted by two mounds of waste accumulations of black, sticky earth and carbonized matter.
12. Layer of brown-coloured, clayey earth and sand, interrupted by streaks of dark earth.
13. Layer of greenish, silted clay, covered by an alluvial streak of gravel and sand.
14. Bottom layer of greenish sand.

In Section I B, the upper six layers are the same as in Section I A. From Layer 7, however, the stratification is different. The strata of Section I A are interrupted by filling layers of a large pit dug down to level 75.5 and from there by another pit dug down to level 61.5—63.5 (cf. Section II, Plan IV). The upper pit is dug with vertical sides and is approximately rectangular in plan, measuring about 7.70 m. × 5.50 m. The lower pit is of an irregularly rounded shape and measures only about 3.25 m. × 2.65 m.

The stratification in this part of the section is thus composed of the following layers:

- 1-6. Layers corresponding to those of Section I A.
 7. Debris of oblique streaks of mud-brick earth and large pieces of lime-mortar.
 8. Layer of brown, silted clay, mixed with building debris of lime-mortar and stones.
- Layer 8 covers the bottom of both the pits and Layer 7 fills up their upper parts. Layer



Fig. 14. Kition. Detail of Section I B, with slabs of Platform 34 to the right.

8 contained a deposit of numerous sculptures thrown into the pits and especially crowded together along the S. long side of the rectangular pit (cf. p. 65). This layer, evidently, represents the clayey earth and building debris brought by the rains into the pits while they still were open, and Layer 7 represents the filling thrown into the pits in order to cover the sculptures buried there and to level the place. From the relation of the filling layers to the pits, it is evident that the lower pit was dug at the same time as the upper one, and that they were filled contemporaneously. It should be observed that the S. side of the lower pit is cut vertical from a ledge-shaped upper part dug from the bottom of the rectangular pit. This ledge-shaped part is only filled with the brown-coloured, clayey earth of Layer 8, but the S. part of the layer has not fallen down to the bottom of the pit as in its remaining part, but was apparently prevented from doing so by an obstacle on a line with the vertical side wall of the pit. Above the ledge-shaped part of the pit, a stone block, which had tumbled down with the building debris of Layer 8, served as such an obstacle. But further down in the ledge-shaped part itself, one may infer the existence of some boards, placed there on a line with the vertical side wall of the pit for some temporary purpose. It was observed that a number of statuettes had been deposited in this part of the pit with their backs leaning against the line of these supposed boards (cf. p. 67, Figs. 28, 29), and it is therefore probable that these assumed boards served as support to these statuettes.

9. Layer of sandy earth, greenish-brown in colour, mixed with culture earth, and resting on a floor of pebbles. A part of the layer is cut away by the lower pit.
10. Culture earth, similar to that of Layer 9, resting on another floor of pebbles. The level of this floor corresponds to the bottom level of Layer 10 of Section I A. As Layers 7—9 of that part of the section are entirely cut away by the rectangular pit, it is evident that Layers 9—10 of Section I B correspond to Layers 10 A—B of Section I A, and the streak of sand between Layers 10 A and B corresponds to the floor of Layer 9 in Section I B.
11. Layer of greenish-brown, sandy earth, containing culture remains, corresponding to Layer 11 of Section I A. The layer rests on a floor of pebbles, partly on a foundation of rubble.
12. Layer of brown-coloured, clayey earth, corresponding to Layer 12 of Section I A.
13. Bottom layer corresponding to Layer 13 of Section I A.

Section I C shows the same sequence of the layers as Section I A.

The section cuts through the following structures: Platforms 35 and 34, Walls 7 A, 3, 8 A—B. The floor of Layer 7 abuts against Platform 35, that of Layer 9 of Section I A against Platform 34; the floor of Layer 9 of Section I B abuts against Wall 8 B, that of Layer 10 against Walls 7 A and 8 A, and that of Layer 11 against Wall 3.

Section II (Plan IV).

This section runs from Square J 8 to Square J 1, in a west-easterly direction. The section is divided into three stratigraphical parts, corresponding to the three parts of Section I: Section II A extending to the E. of the rectangular, large pit, Section II B across this pit, and Section II C to the W. of the same.

The stratification corresponds, in the main, to that of Section I. The following particulars may be observed. In the E. part of the section, the line of demarcation between Layers 12 and 13 continues as a floor of pebbles, and Layer 13 of the preceding part of the section is split up into two layers: Layers 13 and 14 divided by a line of demarcation.

The section cuts through Walls 7 A—B, Altars 36—39, and Platform 34, and shows the west-easterly extent of the lower pit dug from the bottom of the large, rectangular pit.

Sections III—V (Plan V, 1—3).

These sections illustrate the stratigraphic conditions in and below the large, rectangular pit. They run parallel to Section I in a south-northerly direction, Section III from Square I 6 to K 6, Section IV from between Squares H 5—6 to between Squares L 5—6, Section V from Square H 4 to Square L 4. Only the strata from the layers corresponding to Layers 7 of Sections I—II and down to the rock are recorded. The stratification is entirely in accordance with that of the corresponding parts of Section II.

Section III cuts through Platform 34, Altar 36, Walls 3, 8 A—B, Section IV cuts through Platform 34, Walls 3 and 8 A—B, Section V cuts through Platform 34, Altar 37, and Wall 3. Sections III and IV show the south-northerly extension of the lower pit dug from the bottom of the large, rectangular pit; and from Section IV it can be seen that the

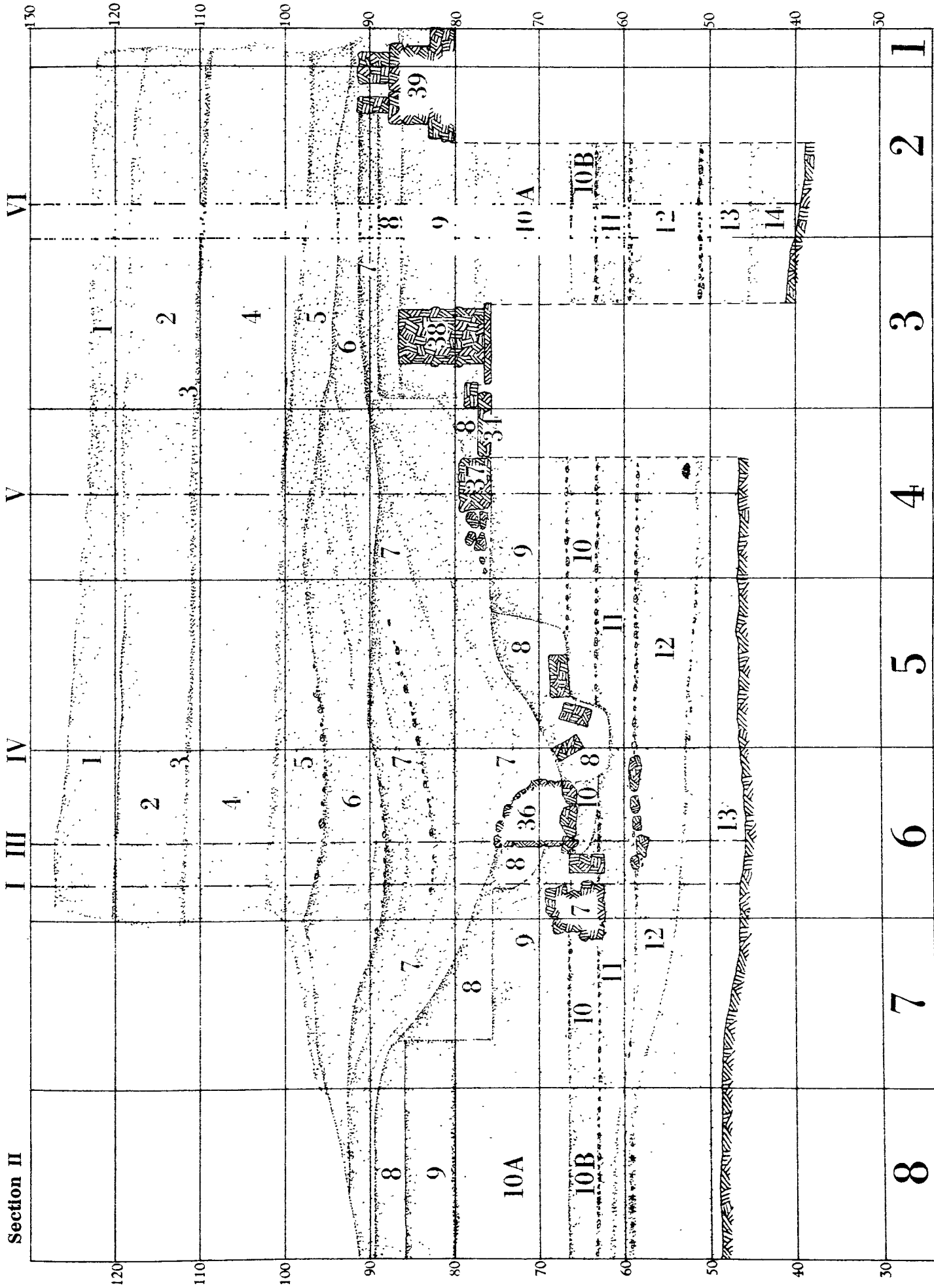



blocks of Wall 8 A which are cut concave, as mentioned in the description of the wall, were hollowed out in connexion with the digging of the lower pit whose border line coincides with the surface of the concave blocks.

Section VI (Plan V, 4).

This section runs in a south-northerly direction from Square I 2 across J 2 to Square K 2. Only the strata from Layer 10 and down to the rock are recorded. The layers are entirely in accordance with the corresponding layers of the part of Section II crossed by Section VI.

Walls 3 and 1 are cut through by the section and the mud-brick remains of Wall 1 are clearly distinguishable. The floor of Layer 11 abuts against Wall 3, that of Layer 12 against the mud-brick remains of Wall 1, and the line of demarcation between Layers 13 and 14 abuts against the stone foundation of Wall 1.

Section VII (Plan VI, 1).

This is an angular section running in a north-westerly direction from Square K 2 to L 2 and turns then in a north-easterly direction within Square L 2. The first part is called Section VII A and the latter one Section VII B. The section illustrates the stratigraphic conditions of the upper strata within the area to the N. of Section II, while the lower strata within this area, as shown above, are registered by Section VI.

Five layers are represented.

The first layer corresponds to Layer 5, the second to Layer 6, the third to Layer 7, the fourth to Layer 8, and the fifth to Layer 9 of Section II C. Layers 1 (5) and 2 (6) are partly dug through by a pit filled with disturbed debris. In Section VII B Layer 2 (6) rests directly on a streak of sand (Layer 3) corresponding to that of Layer 7 in Section II C. In Section VII A, Layer 2 (6) continues down below the floor of Layer 4 (8), showing that within this part of the section the culture earth of Layer 4 (8) and a part of Layer 5 (9), too, had been removed. In Layer 5 (9), there is a thin streak of yellow sand and culture remains of dark earth are accumulated on the floor of lime-concrete.

Section VIII (Plan VI, 2).

This section shows the stratigraphic conditions around Altar 40. Only four strata, i. e. those immediately above and below the altar, and those around it, are registered. The first stratum of building debris corresponds to Layer 6, the second stratum to Layer 7, the third stratum to Layer 8, and the fourth stratum to Layer 9 of Sections I—II. It is seen that the altar is founded in the fourth stratum corresponding to Layer 9 at about level 82.5, the floor of the third stratum corresponding to Layer 8 abuts against it on a level with its moulded base, the second stratum corresponding to Layer 7 abuts against it about 0.20 m. below its top surface, and it is entirely covered by the first stratum corresponding to Layer 6.

Section IX (Plan VI, 3).

This section runs from Square G 4 in a southern direction to Square F 4; after having crossed Wall 12 in that square it turns to the S. E. and continues in that direction to Square

C 2. The section is purely architectural: no strata, but only walls and floors are indicated. The walls cut through by the section are Walls 10, 12, 20, 23 A, 24, 27. Two floors are represented: the lowermost at level 86.0 and the uppermost at about level 89.0.

For the reasons mentioned above, p. 6, and on account of the purpose of our Kition excavations (cf. p. 1) this area of the excavation was not laid bare below level 86.0, with the exception of the walls only, which were examined down to their foundation level. Only floors down to level 86.0 are therefore registered by the section, while the walls cut by the same are represented down to the foundation levels. Walls 10, 12, and 27 are founded on the lower floor and the upper floor, as far as preserved, abuts against them. The lower floor abuts against Wall 20, but is destroyed along Wall 23 A, together with the upper part of the wall itself. It can, however, be proved that the wall is contemporary with Wall 20 (cf. below, pp. 16 f.). Wall 24, finally, is covered by the floor at level 86.0 and must therefore be earlier than it. It can, most probably, be associated with the floor at about level 77.5 of Sections I ff. (cf. below, p. 16).

Section X (Plan VI, 4).

This section runs on top of Wall 20 from Square E 3 to Square D 5 and cuts through the strata from level 104.0 down to the top of Wall 20 at about level 86.0.

Four layers are represented:

1. Layer of building debris.
2. Layer of decomposed mud-bricks and culture earth, resting on a floor of brown, trodden earth.
3. Layer of building debris, decomposed mud-bricks, and culture earth, resting on a floor of lime-concrete.
4. Layer of building debris and decomposed mud-bricks, resting on the stone foundation of Wall 20.

Layers 1—2 correspond to Layers 5—6 of Sections I—II. The floor of Layer 2 (6) is associated with Walls 17—19. Layer 3 corresponds to Layer 7 of Sections I—V A and C, and its floor is the same as that at level 89.0 of Section IX, while Layer 4 corresponds to Layer 8 of Sections I—V A and C.

P e r i o d s.

In order to determine the periods represented by the different strata described above, it is first necessary to determine their interrelations, i. e., make clear which layers correspond to each other. This has already been done in the description of the layers but in order to obtain a comprehensive survey of these interrelations I sum them up here.

Layers 1—6 of Sections I—II correspond to each other as well as Layers 7—10 of Sections I—II A and C, but these do not correspond to Layers 7—10 of Sections I—II B. Within the area covered by these sections, Layers 8—9 of Sections I—II A and C have been removed by the excavation of a large, rectangular pit dug down from the top level of Layer 8 to the bottom level of Layer 9. Layers 7 and 8 of Sections I—II B, by

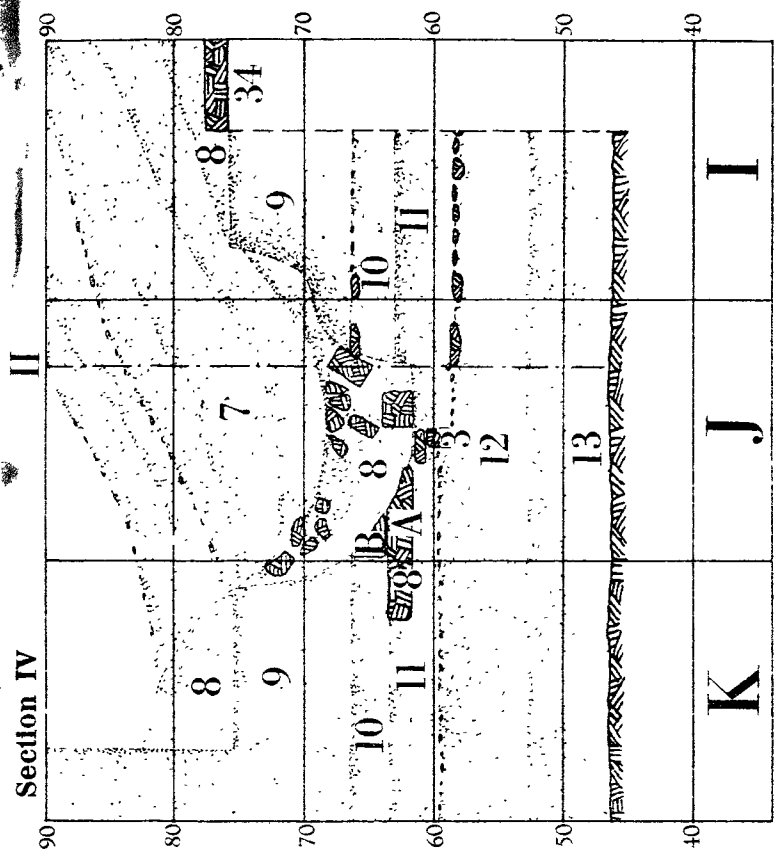
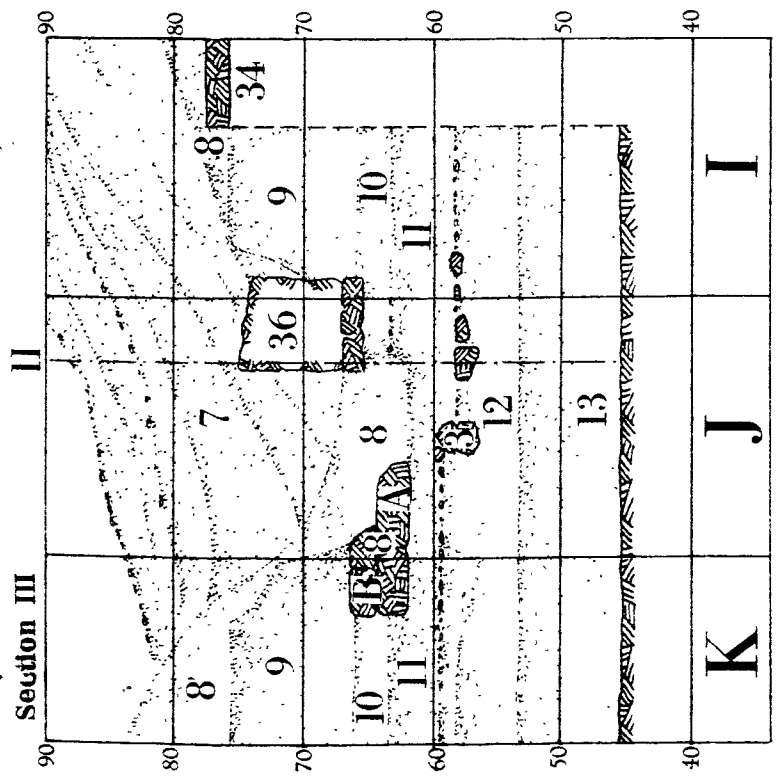

1

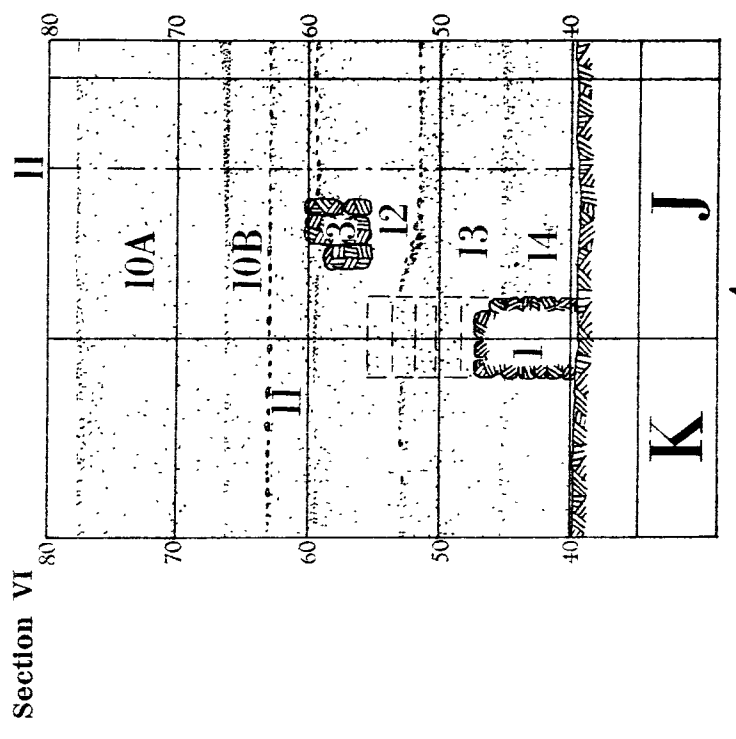
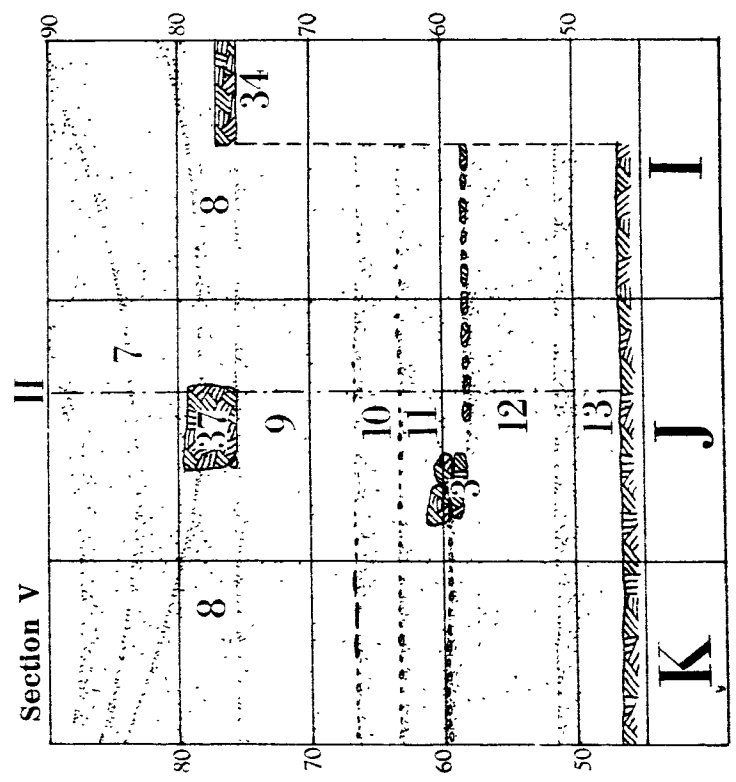

3

2

4

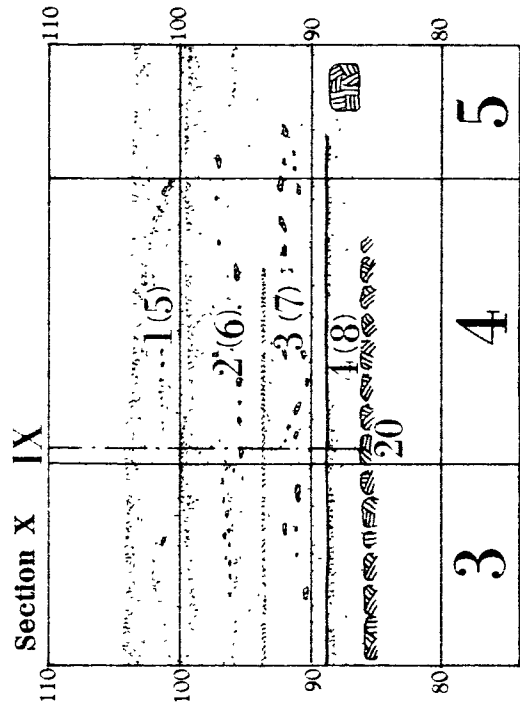
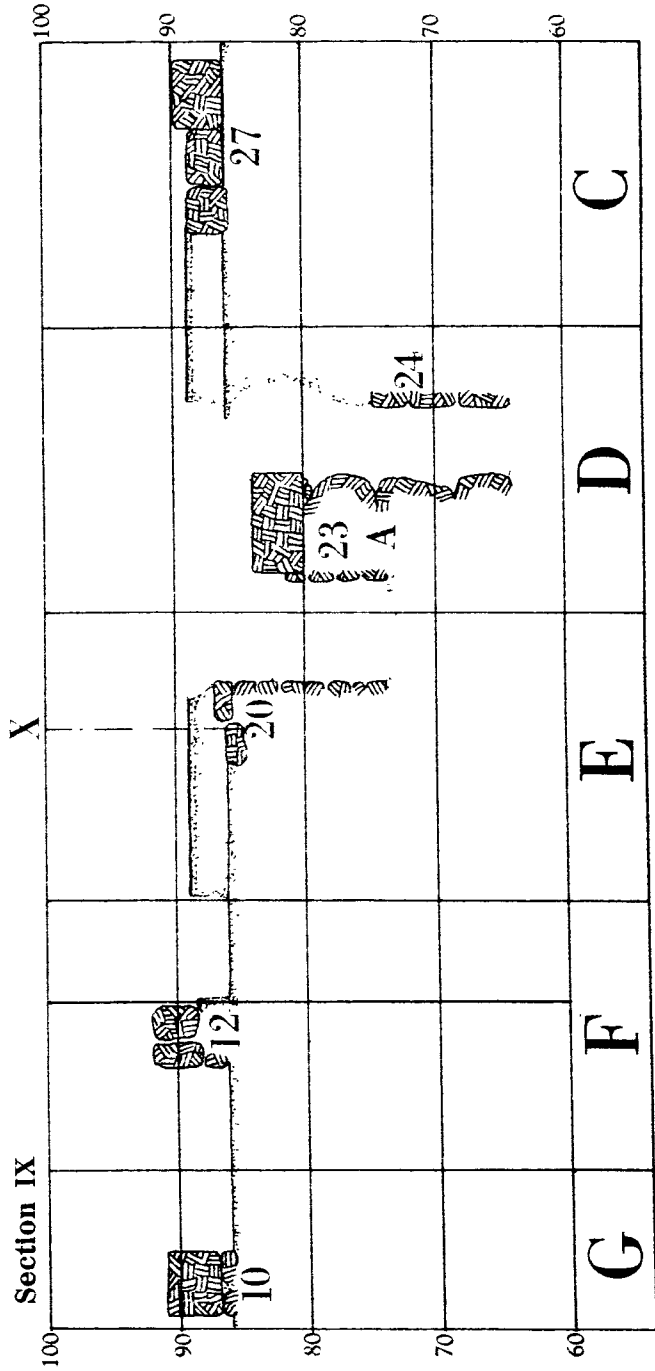
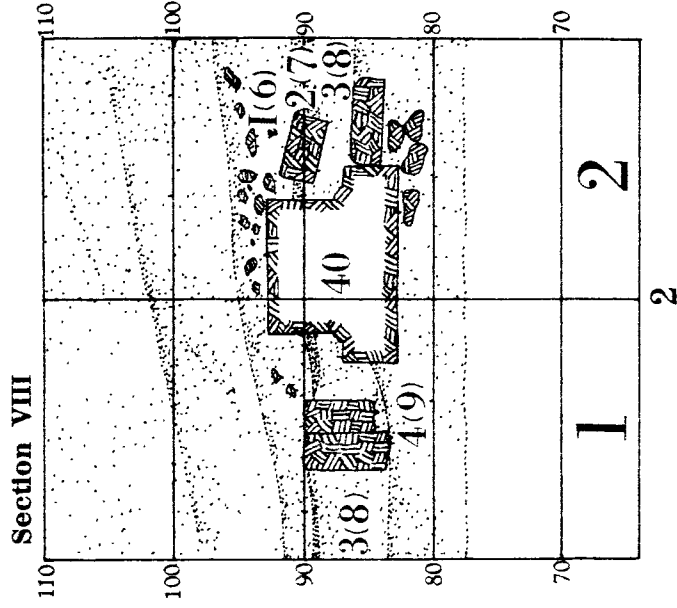
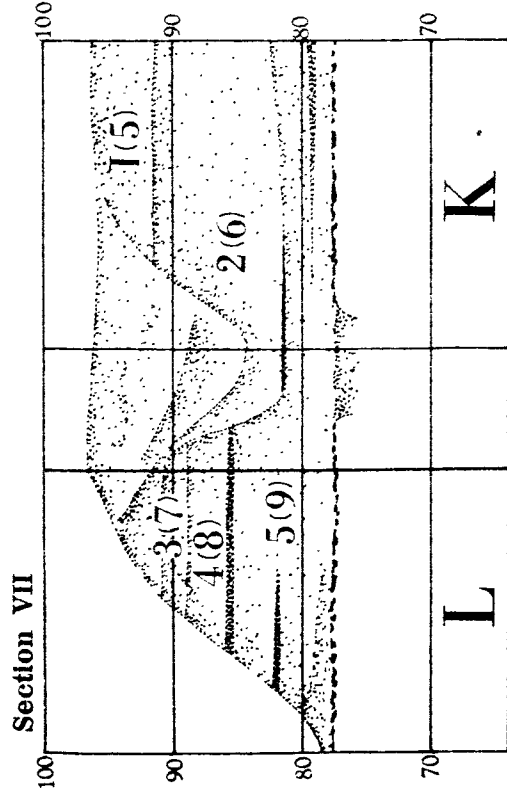

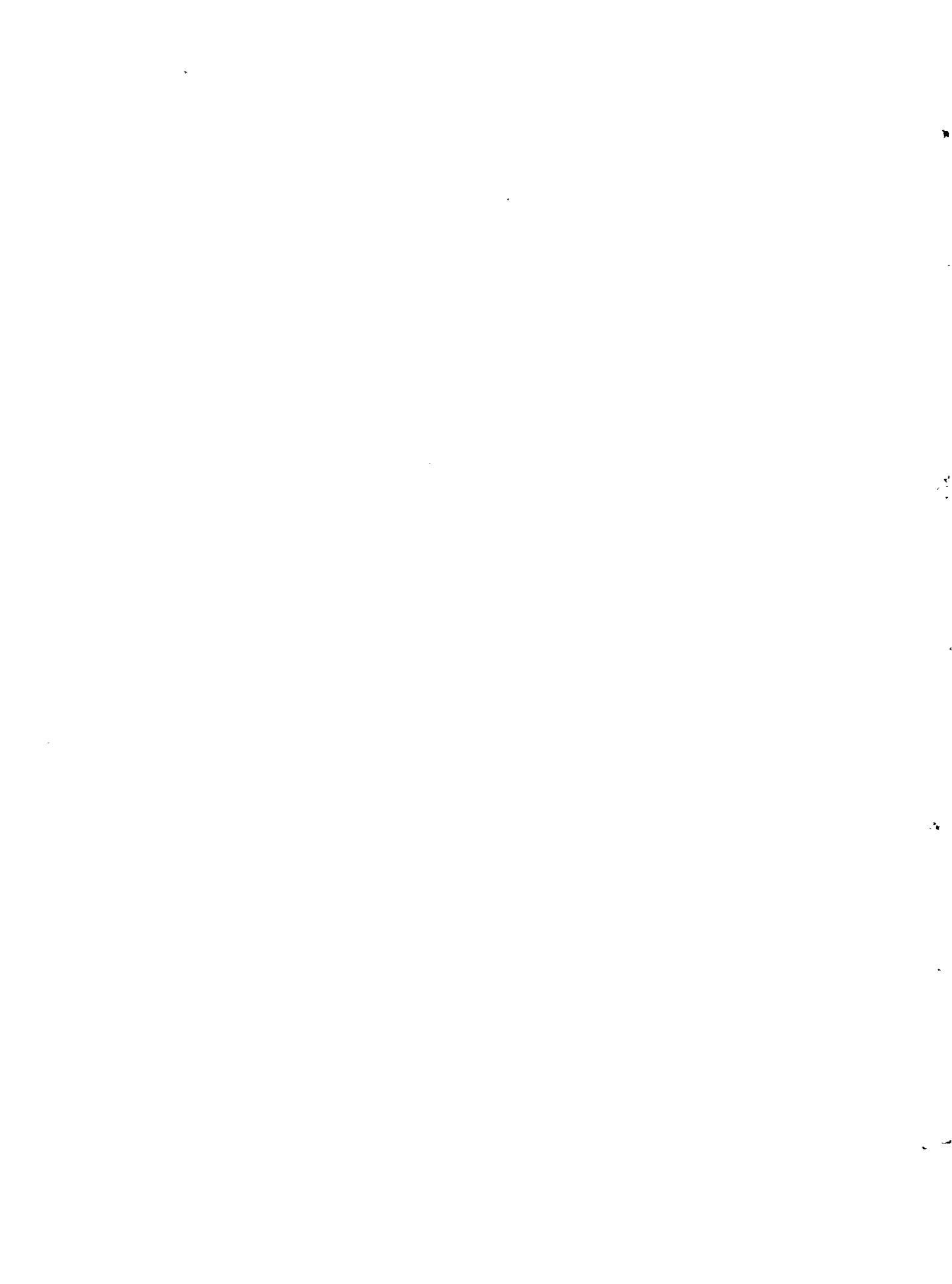

which this pit is filled up, do not therefore correspond to the layers of Sections I—II A and C but consist of filling earth, Layer 8 brought there by the rains while the pit was open, and Layer 7 thrown down the pit on top of the rain-water filling and probably consisting of the mixed earth excavated from the pit. Layer 6 of Sections I—II A and C rests directly on top of this filling. Layers 9—10 of Sections I—II B correspond to Layers 10 A—B of Sections I—II A and C; the floor-level separating Layers 9 and 10 in Sections I—II B not being clearly distinguishable in Sections I—II A and C, but only marked by a streak of sand. From Layer 10 and down to the rock, the layers are uniform again. It should only be noted that in Section II C a floor-level at 46.5 splits Stratum 13 into two layers: Strata 13 and 14.

Sections III—V are entirely in correspondence with Sections I—II B. Only the strata from the layer corresponding to Layer 7 of Sections I—II are represented.

The strata of Section VI correspond to those of Section II A; the strata from Layer 10 to the rock are represented.

In Sections VII, VIII, and X the strata correspond to those of Sections I—II A and C; in Section VII five layers are represented, the uppermost corresponding to Layer 5 and the lowermost to Layer 9; in Section VIII four layers are represented the uppermost of which corresponds to Layer 6 and the lowermost to Layer 9; in Section X four layers, too, are represented, the uppermost corresponding to Layer 5 and the lowermost to Layer 8.

Section IX is purely architectural with no strata, only walls and floors indicated. Of the two floors represented, that at level 89.0 corresponds to the floor of Layer 7 and that at level 86.0 to the floor of Layer 8 of the other sections.

These different strata whose interrelationship has thus been established represent successive periods of habitation. Natural lines of demarcation between these periods are formed by the floors and floor-levels separating the strata and in this way we are able to distinguish ten periods of habitation.

Period 1 is represented by Layer 14 which rests on the rock; Period 2 by Layer 13 resting on the floor-level of rammed earth at level 46.5; Period 3 by Layer 12 resting on the floor at level 50.5—53.5; Period 4 by Layer 11 resting on the floor at about level 59.5; Period 5 by Layer 10 of Sections I—II B, III—V and Layer 10 B of Sections I—II A and C and Section VI resting on the floor at level 63.5; this level coincides with the lower level of the smoothed surface of the base No. 560, built into Wall 7 A (cf. pp. 4 and 64); Period 6 by Layer 9 of Sections I—II B, III—V and Layer 10 A of Sections I—II A and C and Section VI resting on the floor at level 66.5; Period 7 by Layer 9 of Sections I—II A and C, Sections VII—VIII resting on the floor at about level 77.5; Period 8 by Layer 8 of Sections I—II A and C, Sections VII—VIII, and X resting on the floor at level 86.0; Period 9 by Layer 7 resting on the floor at level about 89.0, appearing in Sections IX—X, and Period 10 by Layers 5—6 resting on the floor at level 93.5, appearing only in Section X. The other strata, Layers 1—4, which are only represented in Sections I—II, are not associated with any floor; they consist of building debris and culture remains mixed together without distinction and, consequently, do not represent distinct

strata of habitation but only accumulation of debris. As mentioned above, p. 1, the top layers of Bamboula were cut away in 1879 and the present surface thus represents the ground levelled at that time. It seems probable that the present upper layers of debris within the area examined by us, were mixed and disturbed in connexion with this removal of earth and the subsequent levelling of the place. Layers 1—4 are therefore not considered in this context. Excavations on a larger scale may clear up their provenance and interrelations. The fact that Layer 4 accumulated on a streak of dark earth, marking a trodden surface, seems to indicate that some time elapsed between the end of Period 10 and the subsequent period of habitation, and that the place was uninhabited in the meantime.

ARCHITECTURAL ANALYSIS (FIG. 15)

On the basis of the structural and stratigraphical evidence given above it is easy to attribute the architectural elements to these successive periods of habitation.

Walls 1—2 were erected in Period 1 and were in use to the end of Period 3, as the floors of these periods abut against the walls.

Walls 3—6 belong to Period 4, Walls 7 A and 8 A belong to Period 5, and Walls 7 B, 8 B, and 9 to Period 6 because the floors of these periods abut against the walls.

Altar 36 was built in Period 6. It is founded at level 65.5 in the earth of Layer 10, i. e. Period 5, and the floor of Layer 9, i. e., Period 6, abuts against it.

Platform 34, Altars 37, 38, and Wall 24 belong to Period 7. Platform 34 and Altar 38 can be attributed to this period because the floor of the period abuts against them, and they have not been used later than Period 7 as the floor of Period 8 covers Platform 34 about 0.80 m. above its top surface and is on a line with the top of Altar 38. Altar 37 was surrounded by the filling of the large, rectangular pit and its relation to the original, surrounding layers cannot therefore be ascertained. It is, however, founded at the level of Period 7 and cannot therefore belong to an earlier period. On the other hand, it cannot be later than Period 7, because its top level is much below that of Period 6 (cf. Section II, Plan IV). The altar must therefore be assigned to Period 7. Wall 24 is covered by the floor of Period 8 and must therefore be earlier than that period. Its relation to the floor of Period 7 could not be ascertained as the earth around the wall is much disturbed by later rebuildings. The top blocks of the wall have been removed to serve as building stones for the later walls, but the blocks that remain reach approximately the floor-level of Period 7 (level 77.5), and it cannot therefore be doubted that it belongs to that period.

Walls 20—22 can be attributed to Period 8, because the floor of this period abuts against them, and Wall 20 is covered by the floor of Period 9. Wall 23 A is not directly related to the floor of Period 8 as this is destroyed along the wall (cf. above, p. 14). On the one hand, however, Wall 23 A must be earlier than Wall 23 B which is built on top of it and to a great extent with material taken from the demolished part of the wall; this shows that Wall 23 A must be earlier than Period 9, whose floor abuts against Wall 23 B, where it is preserved close by this wall, e. g., in Rooms 19 and 20. On the other hand, Wall 23 A must be later than Period 7 as the level of this floor — about 77.5 — is considerably below the top of the

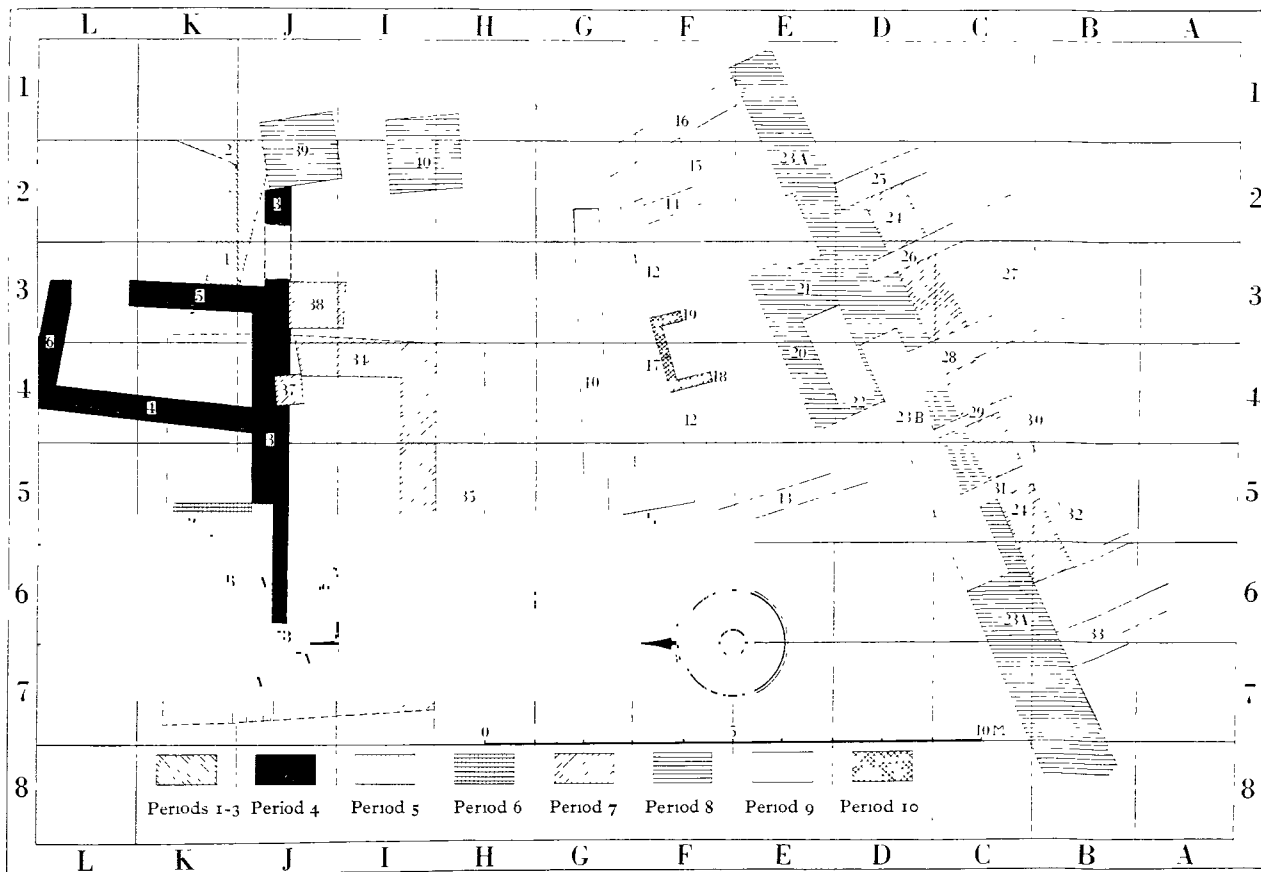

Fig. 15. Kition. Analytical plan of the excavated area.

substructure of the wall. Furthermore, Walls 21 and 22 which belong to Period 8 abut against Wall 23 A. This wall can therefore be assigned to Period 8. Altars 39 and 40 were erected in Period 8 because they are founded in the stratum of Period 7 and the floor of Period 8 abuts against them.

Walls 10—16, 23 B, 25—33, and Platform 35 belong to Period 9. Walls 10—16 are founded on the floor of Period 8 and the floor of Period 9, where it is preserved, abuts against the walls. The same floor abuts against Walls 23 B, 25—33, too, and some of the walls, e. g. Walls 26 and 27, are founded on the floor of Period 8, or in the debris of Period 8, while others, e. g. Wall 23 B, are founded on top of earlier walls. Platform 35 must be later than Period 8 because it is founded on top of the stratum of that period. Furthermore, the earth of Layer 7, i. e., of Period 9 abuts on the slabs of the platform. This platform borders the S. upper edge of the large, rectangular pit. As the layers up to the top of Layer 8, i. e., the stratum of Period 8, are cut through while the platform of Period 9 is laid along the upper edge of the pit it is proved that the pit was dug at the beginning of Period 9.

Walls 17—19, finally, belong to Period 10 as they are partly founded on walls of Period 9 and the floor of Period 10 abuts against them.

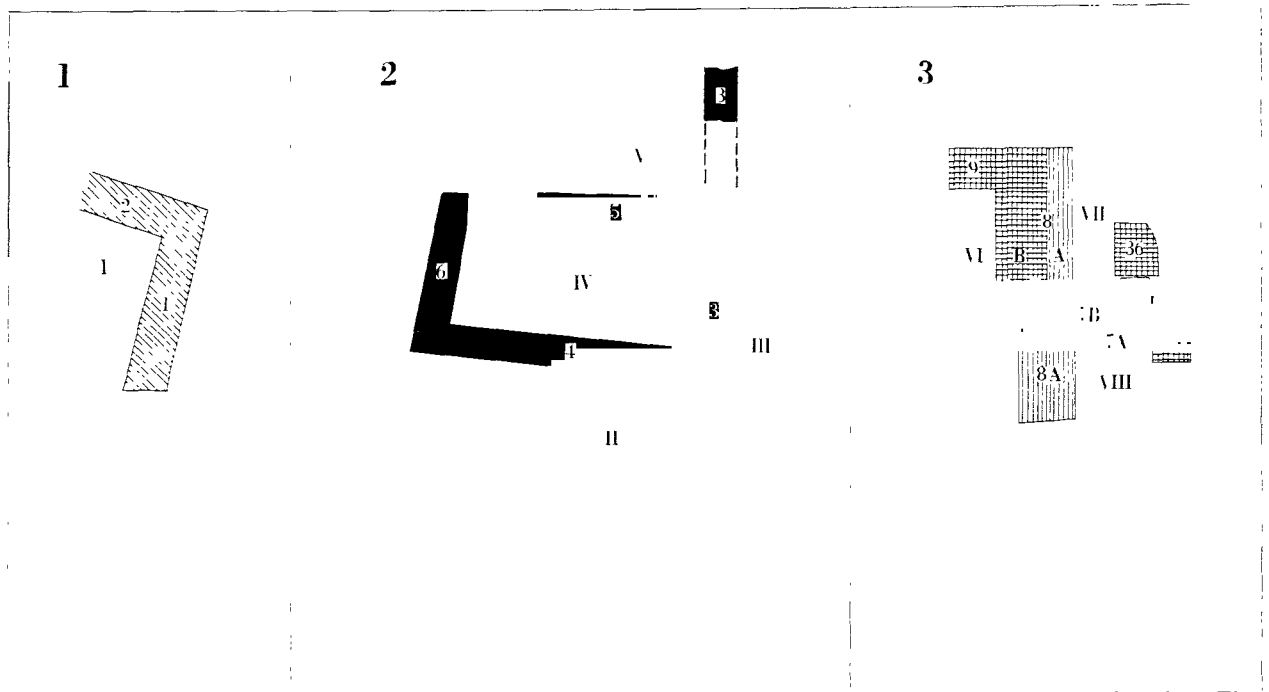

Fig. 16. Kition. Plan of the architecture of Periods 1—3 (1), Period 4 (2), and Periods 5—6 (3).

ARCHITECTURAL SYNTHESIS (FIGS. 16—22; PLAN II)

Many of the periods are only represented by fragments of architecture and the architectural synthesis must therefore, to a great extent, be very fragmentary, too.

Periods 1—3.

The architecture of these periods is only represented by Walls 1 and 2 which form the S. and E. walls of a room, called Room I. The walls are built of mud-bricks, on stone foundations of rubble. The room remained the same from Period 1 to the end of Period 3: the floor-levels were only successively raised. In Period 1 the floor consisted of the levelled rock, in Period 2 of rammed earth (Type 1), and in Period 3 of pebbles (Type 2). The extent of the room is unknown, both its length and width; as the walls are built at right angles to each other, the room seems to have been rectangular in shape. There is no indication that the room formed part of anything else than a secular settlement. The fact that the place from Period 4 to the end of Period 8 was occupied by successive sanctuaries affords of course no proof that the same was the case in Periods 1—3: in Period 10 the place was again occupied by secular buildings (cf. below). As the finds (only potsherds) are not of a character to decide the question, both possibilities must be reckoned with.

Period 4.

The architecture of this period consists of a long wall (Wall 3) dividing the place into two areas, to the N. and S. of the wall, and a rectangular room, called Room IV, built along a part

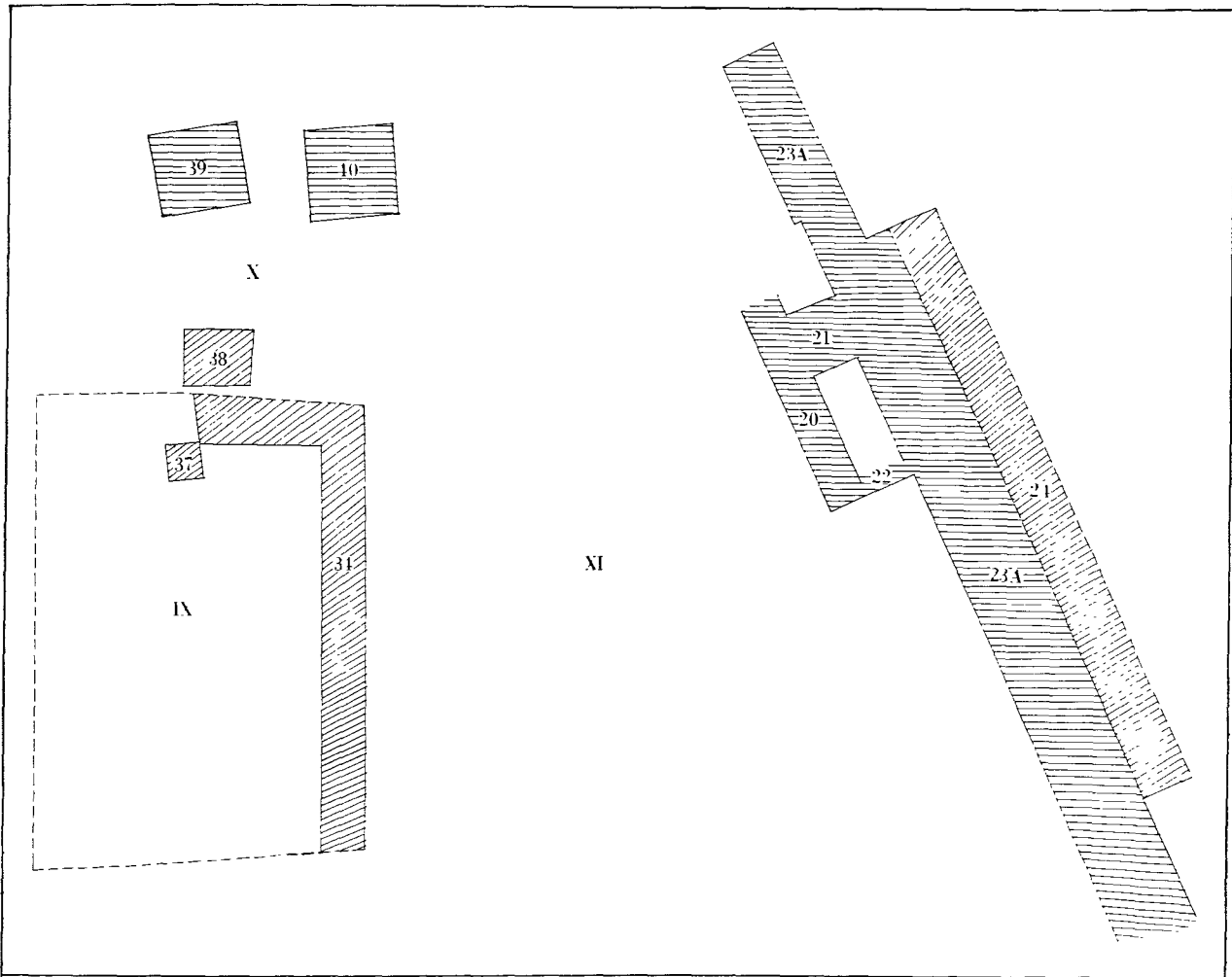

Fig. 17. Kition. Plan of the architecture of Periods 7—8.

of the N. side of Wall 3. The area to the S. of Wall 3 is called Room III, that to the N. of this wall and to the W. of Room IV is called Room II, and that to the E. of this room is called Room V. The structures are thus oriented in west-easterly and south-northerly directions.

Of the walls, only the stone foundations of rubble mixed with a few blocks of sandstone remain. The upper walls may have been of mud-brick or possibly of some other material. The floors are made of pebbles, in Room III partly resting on a foundation of rubble (Type 2).

Rooms II, III, and V seem to have been open areas, Room IV may have been roofed-in. It is roughly rectangular in shape, measuring 4.00 m. \times 1.90 m. At the N. end of Wall 5, a doorway opens into the room. On the opposite side of the room, there is an opening between Wall 4 and 6, too, but that indicates no doorway there; the end pieces of the walls clearly show that the wall has been destroyed.

The finds do not give any clue to the purpose of these structures, but the fact that the structures of Period 5, which are of similar construction and plan, formed part of a sanctuary

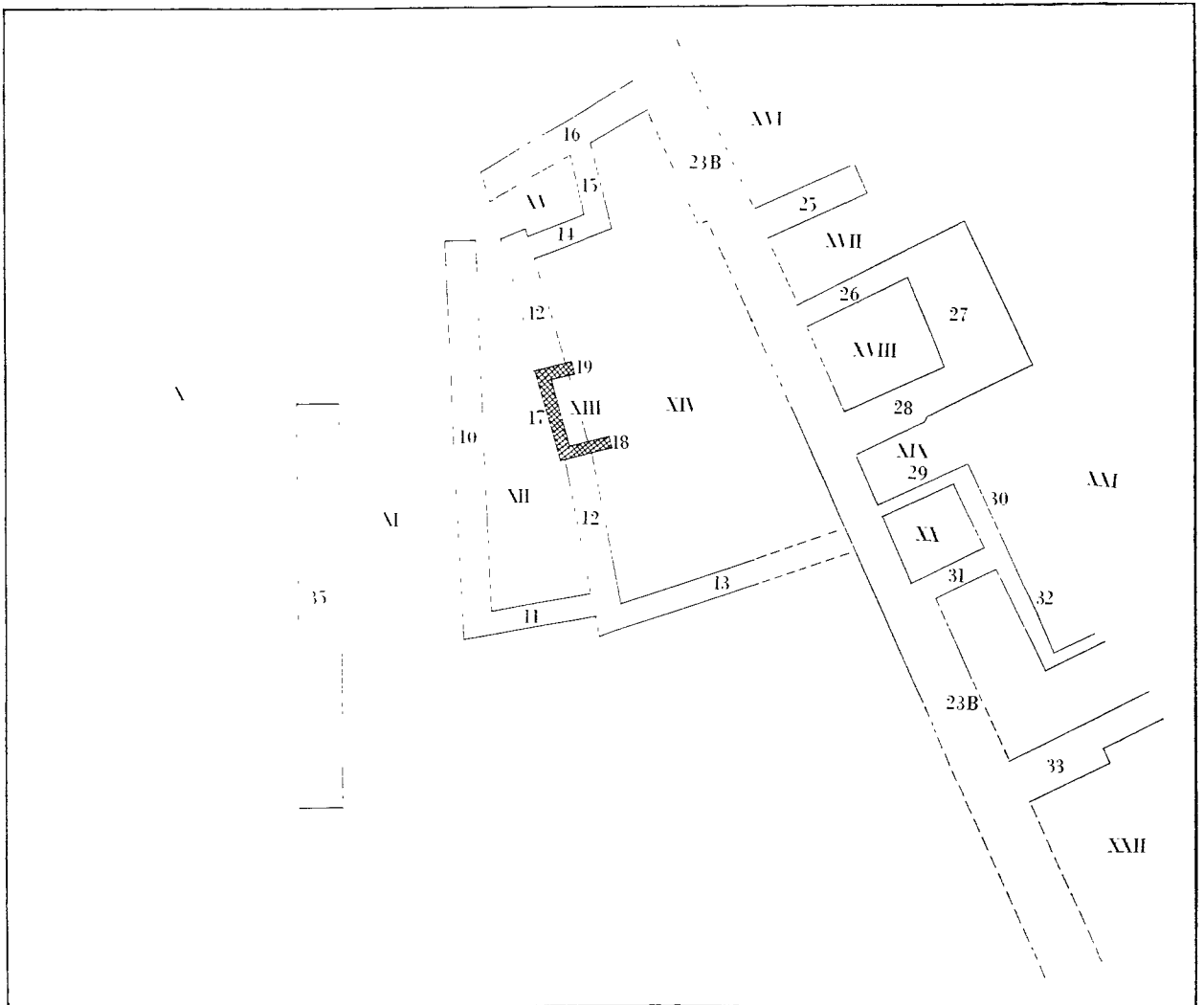

Fig. 18. Kition. Plan of the architecture of Periods 9—10.

(cf. below), indicates that we have to do with remains of a sanctuary in Period 4, too. To judge from what remains the sanctuary was of the temenos type, with open votive and altar courts, and a roofed-in cult-chapel (Room IV), attached to the votive court, a type of temenos represented in many places in Cyprus (cf. Vol. IV), and among the temple-sites examined by the Swedish Expedition similar to that in Idalion (cf. Vol. II pp. 531 f.). The extent and entire plan of the temenos are unknown.

Periods 5—6.

In Period 5, new temenos walls founded on a single course of sandstone blocks were erected (Walls 7 A and 8 A), partly on top of the earlier walls. There is nothing to indicate how the upper walls were constructed. The floor is built of pebbles as in Period 4 (Type 2) but there are no remains of a rubble foundation of the floor.

The preserved walls are built at right angles to each other, Wall 7 A being a transverse

wall to the long Wall 8 A, the transverse wall running in south-northerly direction and the long wall in west-easterly direction. In this way, the excavated part of the temenos was divided into three areas called Rooms VI—VIII. The plan of the structures seems to be similar to that of Period 4 and shows the same orientation as that.

A rectangular base of a statue is built into Wall 7 A, projecting about 0.35 m. from its eastern face. To judge from the preserved feet of the statue this must have been more than life-size. This find, then, proves with certainty that the architectural remains form part of a cult-place, and the location and size of the statue indicate that it was the cult-statue itself.

In Period 6 the temenos remained essentially the same as in the previous period; Wall 9, a transverse wall running in a northern direction from Wall 8, was added and the earlier walls were heightened (Walls 7 B and 8 B) up to the raised floor-level of the new temenos (level 66.5). The floor consisted of sand and gravel, at least partly covered by limestone slabs, which are preserved in Square K 4 (Type 3). Finally, a rectangular altar built of rubble and chips of stone in mud-mortar was erected in front of the cult-statue (Altar 36).

Period 7.

In this period the temenos was entirely re-arranged and by a filling of earth covering the remains of Period 6 the place was raised to level about 75.5—77.5 where a new floor of lime-concrete was laid.

This new temenos was enclosed by a massive peribolos wall of which a short piece was found in Squares C 3 and D 2—3 (Wall 24). This part of the peribolos wall runs in a north-easterly direction.

A part of the temenos enclosed by this peribolos wall was screened off by an inner temenos which was erected exactly above the earlier temenos walls. It was bordered by a platform of rectangular limestone slabs (Platform 34) reminding one of the platform around the inner temenos of Period 6 in Idalion. It is possible that this inner temenos was enclosed by a wooden wall as in Idalion, but that could not be ascertained. The inner temenos forms a rectangular room, called Room IX. It is oriented exactly in a west-easterly direction with the short sides facing E. and W., and the long sides facing N. and S. A low altar consisting of a square limestone block with concave surface (Altar 37) was found close by the E. short side of the inner temenos, inside the platform. It has been somewhat removed from its original place. On the altar and close by, there were remains of ash and carbonized matter. Another altar consisting of a monolithic, moulded pillar (Altar 38) was erected outside the platform close by the same short side.

The extent of the inner temenos cannot be determined with absolute certainty as only the S. part of the E. short side and the S. long side of the bordering platform are preserved, but not a single slab of the W. short side and N. long side, so that neither the length nor the width of the inner temenos are fixed. Its size can, however, be calculated with a high degree of probability. At the excavation of the large, rectangular pit which at the beginning of Period 9 (cf. pp. 11, 21 f., 23 f., 65) was dug down from the top level of the stratum



Fig. 19. Kition. The central part of the excavated area with the depository pits for the sculptures. In the background: Platforms 34, 35. In the foreground, from the left: Altars 38, 37, 36, Walls 7—8: A—B.

of Period 8 to the floor-level of Period 7 one followed the bordering line of the stone slabs of the platform of the inner temenos of Period 7 wherever they are preserved. It seems therefore likely that this platform was followed all round at the excavation of the pit and that its slabs were removed by the persons who dug the pit, from those places where they are now missing. The extent of the inner temenos would then coincide with the extent of the pit. The inner temenos would thus have measured c. 7.70 m. in length and c. 5.50 m. in width. A corroboration of this supposition is given by the fact that the distance from the centre of Altar 38 to the exterior edge of the S. side of the platform is approximately the same as from the centre of the altar to the N. side of the pit: the altar would thus have been placed outside the middle of the E. short side of the inner temenos. In view of this, it seems equally probable that Altar 37, which as mentioned above, was found somewhat removed from its original position, had been originally placed opposite Altar 38 inside the middle of the E. short side of the inner temenos.

This was, consequently, the plan of the sanctuary of Period 7: a large, exterior temenos enclosed by a massive peribolos wall, and a rectangular inner temenos, bordered by a platform of limestone slabs and possibly enclosed by a wooden wall with a low altar consisting of a square stone inside the middle of its E. short side and a pillar altar outside the middle of the same.



Fig. 20. Kition. Detail of the central part of the excavation, with Altar 36, Walls 3 and 7—8: A—B.

Period 8.

The remains of the temenos of the previous period were covered with a filling of earth, about 0.95 m. deep, and the place was raised to level 86.0 where a new floor of lime-concrete, partly covered by limestone slabs, was laid.

The plan and extent of this new temenos seem to have remained essentially the same as in the previous period. A new, massive peribolos wall of which pieces were found (Walls 20—23 A) was built and enclosed the exterior temenos to the S. The wall runs immediately inside the peribolos wall of the previous temenos and in the same direction.

Of an inner temenos no traces were left. It may have been located above that of Period 7 and the stone slabs of its bordering platform have been removed by the persons who dug the large, rectangular pit down to the floor-level of the inner temenos of Period 7.

On the part of the exterior temenos to the E. of this assumed inner temenos, called Room X, two altars were erected (Altars 39 and 40) replacing Altar 38 of Period 7. Both the altars are square in shape, Altar 39 being built of ashlar on a stepped base, and Altar 40 consisting of a monolithic block with moulded base border.

This temenos of Period 8 was the last one of the successive sanctuaries. At the beginning of next period, the temenos was demolished and secular buildings were erected on the place. At the time of the demolition of the temenos its *ex voto*s of sculptures were buried (cf. Con-



Fig. 21. Kitium. View of the house of Periods 9—10, from the West.

ditions of finds, p. 65) in a large, rectangular pit dug through the culture strata down to the level of Period 7 and still deeper by excavation of another pit of irregularly oblong shape, dug from the bottom of the rectangular pit to level 61.5—63.5. While the pits were still open, rain-water brought down earth and building debris into the pits by which they began to be filled, and they were then entirely refilled with a deep layer of mixed debris and culture earth probably consisting of the earth excavated from the pits. At the same time a platform of limestone slabs, probably taken from the removed slabs of the platforms of the inner temene of Periods 7 and 8, was laid along the upper edge of the refilled pits, apparently as a sort of enclosure of the place where the *ex votis* had been buried. Of this platform, only some slabs along the S. long side were left.

Periods 9—10.

When the temenos of Period 8 had been demolished at the beginning of Period 9, a house of secular character was erected on the levelled ground. The house is divided into two separate parts: one to the N. (Rooms XII, XIV, and XV) and another to the S. (Rooms XVI—XXII), each part forming a structural unit. The foundation walls of the N. complex are built of rubble with a covering course of sandstone blocks, while those of the S. complex are built of an inner filling of earth, lime-mortar, and rubble faced with ashlar blocks (Wall 23 B)



Fig. 22. Kition. View of the house of Periods 9—10, from the East.

or on a substructure of rubble, earth, and lime-mortar covered with ashlar blocks (Walls 25—33). The upper walls were built of mud-bricks and the floors were constructed of lime-cement (Type 5). The stone blocks are taken from the earlier temenos walls and the walls of the S. complex are also to a great extent founded on the earlier temenos walls; this is not the case with the walls of the N. complex which are all founded on the floor of the temenos of Period 8.

This difference in construction corresponds to a difference in plan between the two parts of the house. Of the rooms of the N. complex, Room XII is a long, but rather narrow room, measuring 6.00 m. \times 1.65 m.—0.50 m. The room tapers to the E. where the entrance is. Room XIV is a large, roughly rectangular room, measuring 5.90 m. \times 2.50 m.—1.35 m. It is entered by a doorway at the S. end of the W. short wall, and by a rather wide passage between Room XV and the S. complex, on the opposite short side. Some stone blocks serving as a substructure of the threshold in the entrance of the passage were still preserved. Close by the N. long wall of the room, a large storage vessel of terracotta was found *in situ* sunk in a cavity of the floor. Room XV is a small back-room, measuring 1.10 m. \times 0.95 m., and entered by a doorway in its N. front wall.

The S. complex consists of an aligned suite of rooms, all rectangular and rather small in size, built against the S. face of Wall 23 B, and facing a large, open court to the S. In

this court, called Room XXI, the remains of a basalt press for pressing wine or oil was found *in situ* sunk in a cavity of the floor, and to the W. of Room XX narrow, rectangular drainage outlets are built into Wall 23 B through which waste-water was carried off.

The finds of the storage vessel in Room XIV, and the press in the court of the S. complex, and the shape of the rooms, indicate that the building contained store-rooms, press-rooms, and workshops etc., but was no dwelling-house.

In Period 10 a new floor of earth-concrete (Type 6) was laid on the raised level of 93.5 and Walls 17—19 enclosing the recess room XIII were built. Of the other re-arrangements and rebuildings carried out, no traces are left and of the walls of Period 9, only Wall 23 B was still in use. It is therefore not possible to form an idea of the architectural conditions in Period 10.

FINDS

OBJECT REGISTER

1. Ivory *stilus* with conical, latticed head; parallel, encircling incision around pin below head. Length 8.0. B 7. 95.0.
2. Plain iron pin; much worn and defaced. Length 15.4. B 7. 95.0.
3. Terracotta lamp, covered with black glaze almost effaced; with flat, raised base; squat body; central filling-hole surrounded by relief ring; knob on side; rather short nozzle (end missing). Length 8.0. B 7. 95.0.
4. Plain White open, saucer-shaped lamp with flat, raised base; pinched wick-holder; plain rim. Length 7.5. A 7. 93.0.
5. Plain White lamp, as No. 4, but with smaller base and flat rim. Length 6.8. C 7. 93.0.
6. Globular bead of white, blue, and red-veined glass; no central hole. Diam. 2.6. G 7. 95.0
7. Bronze coin; much corroded and indecipherable. Diam. 1.9. Weight 1.6. G 7. 95.0.
8. Fragment of a rounded head with short, curled hair covered by a veil; ears visible. Face missing. White limestone. Height 10.5. Deposit of sculptures. 80.0.
9. Fragment of a terracotta horse Stray find.
10. 7-42-164-523.
Male statue, rather full-bodied (body = No. 10), standing on a rectangular base (base and r. foot = No. 164), with l. leg advanced; sandals with red straps on naked feet; short, rather thick neck; oval head (No. 42) with strong chin; smiling mouth; nose in line with forehead; almond-shaped eyes with lids and marked eyebrows; the hair is short and rendered by radiating grooves on crown of head; wreath of ivy leaves around head; three rows of superimposed cork-screw-shaped curls coming forth below wreath all around head, leaving part of ears visible; long, folded chiton with short sleeves; himation over l. shoulder wrapped around waist and falling in curved, oblique folds over body and a vertical zigzag fold along l. leg. The base with r. foot was found placed on another, larger base of Ajta Paraskevi stone (No. 523) the upper side of which was sunk to receive the base of the statuette. R. arm up to the sleeve of chiton, l. arm, part of shoulders at back missing; broken at base, ankles, and below neck; body and face worn; face repaired in gypsum. White limestone. Height (lower base included) 123.0. Height of statue 99.0. Legs to hips 53.0. Leg to l. knee 29.0. Shoulder width 28.5. Waist width 17.6. Hips width 19.4. Length of feet 15.0. Head height 18.0. Length 13.8. Width 10.0. Deposit of sculptures. 86.0.
11. Fragment of a plank-shaped statuette; badly worn. White limestone. Length 12.0. Deposit of sculptures. 84.0.
12. Fragment of a plank-shaped statuette. White limestone. Length 24.0. Deposit of sculptures. 83.3.
13. Fragment of a statuette, with l. arm carrying an animal. White limestone. Length 21.0. Deposit of sculptures. 82.1.
14. Head, belonging to No. 251. Deposit of sculptures. 82.5.
15. Torso of a Herakles statuette; much damaged. White limestone. Length 43.0. Deposit of sculptures. 81.5.
16. R. leg, belonging to No. 37. Deposit of sculptures. 81.5.
17. Fragment of a base and feet; badly damaged. White limestone. Deposit of sculptures. 84.5.
18. Fragment of a large, plank-shaped statuette; plain surface. White limestone. Height 46.0. Deposit of sculptures. 82.5.
- 19-145-378.
Statuette of a nude Herakles, standing with l. leg (No. 145) advanced and knee slightly bent; r. leg straight; legs in profile, rather carefully worked; feet with sculptured toes; body *en face* with l. arm uplifted and bent back with closed hand attached to the back of head holding a club (now missing); oval head looking over r. shoulder; rounded chin and cheeks; carefully cut mouth with smiling lips; almond-shaped eyes;

- straight nose in line with forehead; hair cut in contiguous rows with notched curls across forehead below lion-skin which falls over the shoulders; the forepaws knotted on the breast. The statuette rests on a roughly rectangular base tablet. (No. 378). L. arm, point of club, and l. back corner of the base tablet missing. White limestone. Height 65.8. Legs to hips 35.5. Legs to knees 17.0. Waist width 10.5. Hips width 12.2. Shoulder width 7.3. Head height 8.2. Length 9.2. Width 6.0. Deposit of sculptures. 83.0.
20. Head, belonging to No. 30. Deposit of sculptures. 83.5.
21. Head, belonging to No. 308. Deposit of sculptures. 83.5.
- 22-111.
Statuette of a nude Herakles, full-bodied; slightly bulging breast; short neck; oval, rounded head (No. 22); straight nose in line with the short forehead; finely cut mouth with smiling lips; roughly cut ears; short hair cut in parallel grooves and tied together by a band around head and a knot on crown of head. The head leans forward. Traces of red colour on lips and on band around head; red club. Part of club at back of head preserved; both arms and legs missing. White limestone. Height 34.0. Waist width 11.8. Head height 10.7. Length 9.3. Width 8.0. Deposit of sculptures. 82.0.
23. Male statuette with plank-shaped body; standing on small base; isolinear feet; r. arm vertical with closed hand; l. arm bent, holding conventionalized buck; sloping shoulders; oval head; face nearly worn away; wreath around head; hair combed over forehead (details worn away); chiton with sleeves ending at elbows; himation over l. shoulder with oblique and vertical, grooved folds. Part of feet and base missing. White limestone. Height 44.0. Breast to back 4.2. Shoulder width 10.1. Deposit of sculptures. 81.7.
- 24-590.
Statuette of Herakles; l. leg slightly advanced; slender body; r. arm lifted; l. arm slightly bent along side of body, its hand grasping the tail of a small lion with head turned back; wearing a short, unfolded chiton with short sleeves ending at elbows; lion-skin hanging down the back; hind paws along the sides of body; forepaws knotted on the breast; girdle around waist; head (No. 590) much damaged. Feet, l. leg up to knee, and r. arm missing; broken in many pieces. White limestone. Height 31.8. Shoulder width 14.0. Waist width 10.0. Hips width 19.0. Deposit of sculptures. 82.5.
25. Fragment of statuette; base, feet, and part of lower body preserved; l. foot slightly advanced; shoes painted red. White limestone. Height 10.0. Deposit of sculptures. 82.2.
26. Fragment of a plank-shaped statuette; body widening downwards; both arms bent across body, holding double flute; feet, part of lower body, of l. arm, part of flute, and head missing. White limestone, surface partly burnt. Length 36.0. Front to back 4.3. Shoulder width 13.0. Deposit of sculptures. 81.0.
27. Fragment of a statuette; only breast of statuette preserved; dressed in chiton, vertically folded; sleeves ending at elbows; himation with oblique folds. Length 21.5. Breast to back 4.4. Deposit of sculptures. 81.0.
28. Male statuette with plank-shaped body, roughly cut; probably isolinear feet; vertical arms along sides of body; wearing long chiton. Traces of red colour visible on chiton. Lower part up to hands, l. hand, and head missing. White limestone. Height 26.2. Breast to back 4.0. Shoulder width 12.6. Deposit of sculptures. 80.5.
29. Fragment of a plank-shaped statuette. White limestone. Length 11.5. Deposit of sculptures. 83.0.
- 30-20.
Male statuette with plank-shaped body; standing on a small, square base; l. foot slightly advanced; r. arm vertical along side of body; forearm slightly advanced with closed hand holding circular object; l. arm bent holding buck along side of body; sloping shoulders; large, rounded, rather broad head (No. 20); rounded plump chin; rounded cheeks; faintly smiling mouth; eyes of myrtle-leaf shape; nose in line with forehead; the hair in front rendered by vertical, nearly parallel incisions; wreath around hair composed of leaves and fruits; short hair at back of head; long chiton with carelessly grooved, vertical folds; sleeves ending at elbows; himation over both shoulders with similar folds and borders painted red. Red on lips. L. hand and forelegs and head of buck missing. White limestone. Height 45.5. Breast to back 4.3. Shoulder width 13.5. Head height 8.2. Length 5.3. Width 5.4. Deposit of sculptures. 82.7.
31. Lower part of plank-shaped statuette, with l. foot slightly advanced. White limestone. Length 12.6. Deposit of sculptures. 80.0.
- 32-205.
Statuette of Herakles; l. leg advanced; short r. arm raised; r. hand (No. 205) holding club behind back of head; l. arm sharply bent; wearing chiton with short sleeves and lion-skin over the head; lions' eyes and ears marked; a row of cut curls visible at l. and r. side of forehead near the ears; lion-skin falling along the back; its forepaws knotted on the breast. Feet, legs up to knees, part of club, and l. hand missing; r. arm broken; broken between breast and neck; surface much worn; head damaged. White limestone. Height 38.0. Shoulder width 19.4. Waist width 10.8. Deposit of sculptures. 79.0.
- 33-191+213+303+310.
Male statuette, full-bodied, with free legs; standing on a square base; l. leg well advanced; both arms advanced; closed hands; the r. hand holding cylindrical object with flat top (box?); the object in the l. one now missing; hands pierced by holes in which the objects were inserted; upper part of breast rather flat; oval head with rounded cheeks; chin chipped; smiling lips; nose in line with forehead, the eyes of myrtle-leaf shape; the hair is short, rendered by

- radiating grooves on crown of head; narrow band around head knotted in front; three rows of superimposed cork-screw curls coming forth from the band round head leaving part of ears visible; wearing short, folded chiton with overfold ending at knees; short sleeves ending at elbows; girdle around waist knotted in front, decorated with incised notchings and painted red; red shoes. Face worn. White limestone. The cylindrical object (box?) was found separately and may not belong to the statuette. Height (base included) 80.0. Legs to hips 39.0. Legs to l. knee 18.0. Shoulder width 22.3. Waist width 13.4. Hips width 15.5. Head height 14.0. Length 11.5. Width 8.5. Base 12.5. 21.5. 4.5. Deposit of sculptures. 76.0.
34. Fragment of a plank-shaped statuette; l. arm slightly advanced, its hand holding buck by the legs; chiton with folds marked by vertical grooves, himation over l. shoulder falling obliquely across body; folds marked by curved grooves. R. arm, lower part of body, and head missing; surface much worn. White limestone. Length 26.0. Deposit of sculptures. 82.7.
35. Upper part of statuette, belonging to No. 202. Deposit of sculptures. 81.7.
36. Fragment of statuette, much worn. Lower part, hands, and head missing. Grey limestone. Height 20.5. Deposit of sculptures. 84.0.
- 37 -16.
Statuette of Herakles, standing with l. leg slightly advanced; body straight and rather slender; head looking forwards; some cut curls of hair on forehead, lion-skin on head falling along back of body; hind paws hanging down to knees along the thighs; fore-paws knotted on the breast, the skin is wrapped up in a wide girdle around the waist. The details of face entirely worn away; surface worn; l. leg up to knee and both arms missing, broken at r. thigh and at waist. White limestone. (R. leg = No. 16). Length of upper part 45.0. Length of r. leg (fragment) 40.0. Deposit of sculptures. 81.5.
- 38-39.
Lower part of statue with base, right foot slightly advanced; sandals with straps; torso much worn. Height 105.0. Deposit of sculptures. 80.1.
40. Lower part of a statue, standing on a small base; r. foot slightly advanced; feet with shoes painted red; wearing long chiton hanging over the legs with symmetrical, fin-shaped folds; of the himation only three vertical folds are visible, one at either side of the legs and one in the middle, thus leaving the legs uncovered. Upper part of statue from the hips missing; upper part of fragment worn. White limestone. Height 70.0. Width 27.0. Deposit of sculptures. 77.0.
- 41 -160
Fragment of Herakles statuette, attitude as No. 32-205, but much chipped so that no details are visible; wearing a short chiton which is only visible between the knees; only fragments of the head of lion-skin preserved. Feet, legs up to knees, r. arm, l. forearm, and face missing; broken at neck; surface entirely damaged. Soft, white limestone. Height 49.0. Shoulder width 23.0. Waist width 14.0. Hips width 15.5. Deposit of sculptures. 80.5.
42. Head, belonging to No. 10. Deposit of sculptures. 80.5.
- 43 -49-395.
Statuette with plank-shaped body, widening upwards; standing on a small base with feet isolinear but diverging, shoes painted red (No. 395); vertical arms close to the sides; wearing long chiton with sleeves ending at elbows. R. arm, l. hand, part of l. shoulder, and head missing. White limestone. Height 36.8. Breast to back 4.7. Shoulder width 12.0. Deposit of sculptures. 81.0.
- 44-321-327.
Male statuette, with plank-shaped body, slightly widening upwards; l. foot slightly advanced; both arms slightly advanced, l. hand holding lyre; wearing a chiton with vertical folds, reaching down to feet; over this a second, plain chiton; over that a short shawl with parallel folds, draped over the shoulders and covering breast, traces of red on shoes, the second chiton, and shawl. Only chin and nose of face preserved; r. hand missing; upper part of statuette worn. White limestone. (Lower part of statuette = No. 44). Height 53.0. Breast to back 5.9. Head length 7.2. Head width 5.0. Shoulder width 14.6. Deposit of sculptures. 81.5.
45. Fragment of a plank-shaped statuette. White limestone. Length 25.0. Deposit of sculptures. 80.7.
46. Fragments of a plank-shaped statuette; much damaged. White limestone. Deposit of sculptures. 82.5.
47. Fragment of a plank-shaped statuette; much damaged. White limestone. Length 12.0. Deposit of sculptures. 80.9.
48. Fragments of a plank-shaped statuette; much damaged. White limestone. Deposit of sculptures. 80.0.
49. Fragment, belonging to No. 43. Deposit of sculptures. 80.0.
50. Fragment of statuette with base, feet, and part of lower body preserved, l. foot advanced; plain chiton. White limestone. Length 22.5. Deposit of sculptures. 80.0.
51. Fragment of a head. Much damaged. White limestone. Height 16.0. Deposit of sculptures. 81.7.
- 52-576.
Male statuette with plank-shaped body; r. arm almost vertical along side of body; l. arm bent and advanced, holding an object of which remains are visible at side of body, sloping shoulders, oval head (No. 576); strong chin; rounded cheeks, nose in line with forehead; oblique eyes of myrtle-leaf shape; roughly cut ears; the hair on crown of head is rendered by grooves radiating from back of head; band around head; front hair marked with zigzag notchings; long hair falling at sides of neck with curls rendered by slightly curved grooves; long, plain chiton; plain himation over l. shoulder with marked borders. Lower part of

- statuette and both hands missing. White limestone, burnt grey at r. side of body. Height 37.5. Breast to back 5.0. Shoulder width 15.0. Head height 10.3. Length 6.5. Width 5.7. Deposit of sculptures. 80.5.
- 53 + 142 + 163 + 241.
Statuette of Herakles standing on a trapezoid base (No. 53); l. leg slightly advanced (No. 142); shoes painted red; straight, slender body (No. 163); r. arm (most parts now missing) lifted (No. 241); l. arm probably free from body and slightly bent, its hand grasping a small lion of which only a fragment is visible on l. thigh; wearing chiton ending at knees; the lion-skin falls along the back; forepaws knotted on the breast; hind paws hang along sides of legs and the tail along r. leg; a girdle is visible at waist on the l. side. Head, neck, r. forearm, and l. arm missing; broken; much worn. White limestone. Height 93.0. Shoulder width 32.8. Breast width 16.5. Waist width 15.3. Hips width 18.0. Base 17.0 × 19.0. Deposit of sculptures. 79.3.
- 54 + 94.
Male statuette with plank-shaped body, standing on a small base with l. foot advanced; shoes painted red; vertical arms along sides of body; closed hands; sloping shoulders; wearing long, plain chiton with short sleeves; himation over l. shoulder with a vertical fold down to the knees along l. side of body. L. arm and head missing; broken. White limestone. (Lower part of body = No. 54). Height 77.0. Breast to back 5.8. Shoulder width 21.3. Deposit of sculptures. 79.5.
55. Fragment of a head with short, convex cap with upturned cheek-pieces and elongated top. L. side of head missing; face worn out. White, slightly greyish limestone. Height 11.2. Length 4.6. Deposit of sculptures. 76.6.
- 56 + 58 + 95 + 193.
Statuette of Herakles with strong l. leg well advanced (No. 56); straight body (Nos. 58, 95); r. arm lifted (now missing); head (No. 193) looking forwards; wearing short, unfolded chiton over both shoulders, decorated with roughly incised chequers; lion-skin over head falling down the back; its hind paws hanging down the sides; its forepaws knotted on the breast; girdle around waist. Feet, r. leg and hip, r. arm, most part of l. arm missing; breast and face much worn; broken and damaged. White limestone. Height 78.0. Waist width 16.5. Deposit of sculptures. 80.5.
57. Oval head with rounded chin and cheeks; slightly smiling lips; nose in line with forehead; eyes of myrtle-leaf shape; hair over forehead rendered by shallow notchings; wreath of two rows of berries; hair on head roughly sculptured; slightly notched, long hair at back of head; plain ears. Much worn. White limestone. Total height 11.0. Head height 9.0. Length 7.6. Width 5.2. Deposit of sculptures. 78.4.
58. Fragment of body, belonging to No. 56. Deposit of sculptures. 81.0.
59. Fragment of a plank-shaped statuette; much damaged. White limestone. Length 44.5. Deposit of sculptures. 79.8.
60. Fragment of a large, plank-shaped statuette; only small part preserved; much worn. White limestone. Length 28.0. Deposit of sculptures. 82.0.
61. Fragment of head with wreath around head; hair rendered by grooves on head, ending in two rows of curls. The face is completely damaged. Back part of head missing. White limestone. Total height 18.4. Head height 10.3. Width 10.0. Deposit of sculptures. 81.8.
- 62 + 182 + 370.
Female statuette, rather full-bodied (upper part of body = No. 182) with roughly sculptured back; standing with l. foot advanced on a trapezoid base (lower part of body = No. 62); r. arm bent over slightly prominent breasts; l. arm along the side of body, slightly advanced and free from body; wearing a plain chiton down to feet with sleeves ending at elbows; short himation over r. shoulder draped with thin, vertical and curved folds at front of body and hanging over the r. bent arm in a long zigzag fold, which is free from body; l. hand holding a fold of himation; bracelet on l. arm. Part of r. forearm, r. hand, and head missing. Worn at breast. White limestone. Height 62.0. Front to back 11.0. Shoulder width 20.0. Deposit of sculptures. 81.5.
63. Base and feet of statuette; l. foot advanced; shoes painted red. White limestone. Length 9.6. Deposit of sculptures. 81.8.
- 64 + 68 + 460.
Statuette of Herakles in frontal position with l. leg advanced (No. 68); legs carefully worked; r. arm was raised (now missing); l. arm vertical; its hand was holding some object (probably a lion) of which only traces preserved on the l. thigh; oval head (No. 460), slightly bent to the l.; soft cheeks; smiling mouth; almond-shaped eyes without lids; plain ears, roughly cut; the hair is rendered by vertical grooves on top of head and is curled over forehead; band around head; dressed in a chiton with overfold ending above knees; flat folds at sides; a girdle around waist; red band around head. Body and face worn. Lower part of legs, r. arm, l. forearm, nose, and back part of head missing. White limestone. Height 47.6. Breast to back 6.6. Shoulder width 15.2. Waist width 9.5. Hips width 10.1. Head height 9.2. Width 6.1. Deposit of sculptures. 77.0.
65. Fragment of head with plain hair falling along side of neck; short neck; disc-shaped ears. Face missing. White limestone. Height 12.0 (neck included). Deposit of sculptures. 76.7.
66. Fragment of a statuette. White limestone; much worn. Length 7.0. Deposit of sculptures. 76.8.
67. Oval, long head with prominent, narrow chin; thin, smiling lips; nose in line with forehead; eyes of myrtle-leaf shape; slightly conical cap on head; no hair visible. Traces of red on helmet. Both sides of head missing. Height 12.3. Length 5.0. Deposit of sculptures. 76.0.

68. L. leg, belonging to No. 64. Deposit of sculptures. 78.0.
69. Fragment of head; damaged and much worn; long, plain hair. Height 8.5. Deposit of sculptures. 76.9.
70. Fragment of a plank-shaped body; vertical arms along sides of body; wearing a chiton. Height 16.9. Deposit of sculptures. 76.9.
71. Small, oval head with strong chin; smiling lips; eyes of myrtle-leaf shape; nose in line with forehead; long, plain hair falling behind the large, roughly shaped ears. Part of l. side missing and worn. Height 7.0. Length 4.4. Deposit of sculptures. 76.5.
72. Fragment of r. leg of statuette. White limestone. Height 14.0. Deposit of sculptures. 76.1.
73. Hand holding a bowl with low foot; rounded outline; horizontal handles; moulded rim. The bowl is solid and upper surface painted red. White limestone. Length 11.5. Deposit of sculptures. 76.5.
74. Curved fragment of white limestone, square in section; possibly the rim of a large stone bowl. Length 22.0. Deposit of sculptures. 75.8.
- 75 + 231. Upper part of statuette; plank-shaped body; l. arm bent, holding conventionalized buck; r. arm vertical; vertically grooved chiton; himation over l. shoulder with folds rendered by oblique grooves; oval head with prominent chin and cheeks; softly smiling mouth; long eyes of myrtle-leaf shape; nose in line with forehead; wreath around head; curled hair over forehead, the curls rendered by superimposed, notched rows; on crown of head shallow, grooved lines. Lower part of body, part of neck, and back of head missing. Surface worn. White limestone. Height 25.2. Breast to back 5.7. Shoulder width 12.5. Head height 9.0. Length 6.7. Width 5.2. Deposit of sculptures. 75.9.
76. Fragment of a female statuette with plank-shaped body, elliptical in section; oval head with details worn off; hair covered by a folded veil; wearing folded chiton and folded himation, the folds rendered by careless grooves. Only upper part of statuette preserved. Surface much worn. White limestone. Height 17.0. Breast to back 3.6. Shoulder width 7.4. Deposit of sculptures. 76.0.
77. Fragment of a leg, with a small part of folded dress attached to it. White limestone. Length 12.0. Deposit of sculptures. 75.1.
78. Fragment of body, belonging to a plank-shaped statuette; vertical arms; wearing chiton with short sleeves. On lower part of fragment thick, red colour. White limestone. Height 9.7. Shoulder width 5.6. Breast to back 2.2. Deposit of sculptures. 75.5.
79. Fragment of a plank-shaped statuette. White limestone. Length 16.0. Deposit of sculptures. 76.0.
80. Fragments of a plank-shaped statuette; much damaged. White limestone. Deposit of sculptures. 75.9.
81. Base and feet of statuette; foot advanced; toes marked by rather careless grooves. White limestone. Length 9.0. Deposit of sculptures. 76.2.
- 82-450. Male statuette with plank-shaped body (No. 82); l. arm almost vertical along side of body, with closed hand; r. arm bent over breast, its hand holding a buck around its body; head wearing a wavy diadem with curled hair below; the hair falls in a compact mass at back of head leaving the ears uncovered. Lower part of statuette and part of l. side missing; chin chipped; face and surface much worn. White limestone. Height 41.5. Breast to back 5.0. Shoulder width 12.0. Head height 7.5. Length 5.4. Width 4.5. Deposit of sculptures. 76.0.
83. Fragment of a male statuette with plank-shaped body. Lower part of body up to r. elbow and head missing. White limestone. Height 15.0. Breast to back 5.1. Shoulder width 3.9. Deposit of sculptures. 77.0.
84. Fragment of a plank-shaped statuette; much damaged. White limestone. Deposit of sculptures. 76.5.
85. Lower part of a plank-shaped statuette, with isolinear feet peeping out of plain chiton; resting on a small base tablet. White limestone. Length 12.0. Deposit of sculptures. 76.1.
86. Fragment of a plank-shaped statuette. White limestone. Length 13.0. Deposit of sculptures 77.0.
87. Fragment of head; only part of back of head with short hair preserved. Height 9.1. Width 6.1. White limestone. Deposit of sculptures. 76.0.
88. Breast of a plank-shaped statuette; chipped and worn. White limestone. Length 15.0. Deposit of sculptures. 80.0.
89. Fragment of a plank-shaped statuette. White limestone. Length 13.0. Deposit of sculptures. 80.0.
90. Fragment of a plank-shaped statuette; much worn. White limestone. Length 24.0. Deposit of sculptures. 81.5.
91. Torso of a male statuette, as No. 308. Lower part of statuette, l. hand with part of bird, and head missing; much worn. White limestone. Height 34.0. Breast to back 5.8. Shoulder width 15.5. Deposit of sculptures. 80.5.
92. Fragment of a plank-shaped statuette; l. arm vertical; r. arm bent upwards and slung in a fold of himation. Lower part of body, most of l. arm, and head missing; surface badly worn. White limestone. Length 36.0. Deposit of sculptures 80.0.
93. Fragment of statuette; base, feet, and lower part of body preserved; l. foot advanced; vertical folds of himation between legs. White limestone. Length 25.0. Deposit of sculptures. 80.5.
94. Upper part of body, belonging to No. 54. Height 30.0. Deposit of sculptures. 80.0.
95. Fragment of body, belonging to No. 56. Deposit of sculptures. 77.0.
96. Head with rounded, fat cheeks; almost straight lips; narrow eyes of myrtle-leaf shape; short, convex cap on head; hair visible over forehead; plain, disc-shaped ears. Part of r. side of chin, nose, r. eye, and part

- of forehead missing. White limestone. Height 12.5. Width of neck 4.8. Deposit of sculptures. 76.9.
97. Fragment of plank-shaped body; l. upper arm close to the side; vertical fold on himation at l. side. Traces of red on chiton and himation. White limestone. Height 23.5. Belly to back 3.0. Width 10.7. Deposit of sculptures. 77.3.
98. Terracotta lamp, saucer-shaped; pinched rim. Length 9.0. Deposit of sculptures. 78.5.
99. Fragment of a plank-shaped statuette; isolinear feet resting on small base tablet; toes marked by grooves; l. arm vertical, attached to body; closed hand; r. arm bent over breast and slung in a fold of himation; plain chiton with long sleeves and plain himation. R. foot and head missing. White limestone, burnt on surface. Length 14.0. Deposit of sculptures. 80.8.
100. Oval head with nose in line with forehead; slightly smiling mouth; rather prominent chin; flattened cheeks; eyes of myrtle-leaf shape with lids; wreath around head; three to four notched rows of curled hair over the forehead. Mouth damaged; face worn and damaged; back and l. part of crown of head missing. White limestone. Height 19.5. Width 9.7. Deposit of sculptures. 78.0.
101. Fragment of statuette; only part of torso preserved; l. arm vertical; part of arm missing. White limestone; much worn. Length 42.0. Deposit of sculptures. 79.8.
102. Base and feet of statuette; l. foot slightly advanced; shoes painted red. White limestone. Length 12.2. Deposit of sculptures. 79.3.
103. Oval head with wreath around head; hair rendered by grooves ending in curls over forehead. Face missing. White limestone. Height 19.1. Deposit of sculptures. 78.0.
104. Oval head with softly rounded chin; smiling lips; full cheeks; narrow eyes of myrtle-leaf shape with lids; short hair rendered by parallel grooves on crown of head and by latticed grooves on forehead and at back of head; wreath with narrow, lancet-shaped leaves around head; only lower part of ears visible. Nose missing; chipped on r. cheek and forehead. White limestone, slightly yellow. Height 11.9. Length 11.3. Width 7.4. Deposit of sculptures. 80.3.
105. Head of statuette; face entirely damaged; short hair, on top of head marked by radiating grooves; wreath of erect leaves around head. White limestone. Height 12.0. Deposit of sculptures. 78.0.
106. Fragment of plank-shaped statuette; body tapering downwards; r. arm vertical; lower part of body, l. arm, upper part of body missing. Chipped surface. White limestone. Length 30.0. Deposit of sculptures. 78.3.
107. Base and feet of statuette; l. foot slightly advanced; shoes painted red. White limestone. Length 10.0. Deposit of sculptures. 78.0.
- 108 + 109. Fragment of plank-shaped body; broken. Grey limestone. Height 25.0. Belly to back 4.0. Shoulder width 15.7. Deposit of sculptures. 78.3.
110. Fragment of torso of Herakles statuette, rather full-bodied; much damaged. White limestone. Height 18.5. Deposit of sculptures. 77.9.
111. Torso of Herakles; see No. 22. Deposit of sculptures. 78.5.
112. Fragment of plank-shaped statuette; l. arm attached to body, slightly bent forwards; closed hand; eyes of myrtle-leaf shape; plain ears; hair rendered by grooved lines, falling at back of head in compact mass. Lower part of body and l. part of fragment missing. White limestone. Length 23.5. Deposit of sculptures. 77.9.
113. Fragment of l. arm with closed hand. White limestone. Length 9.0. Deposit of sculptures 78.2.
- 114 + 247 + 249 + 349. Lower part of body, belonging to a statuette as No. 54-94. White limestone. (Base and feet = No. 349). Height 38.5. Body to back 6.4. Deposit of sculptures. 79.7.
115. Torso of a Herakles with l. leg advanced; straight body; r. arm lifted; l. arm sharply bent with forearm free from body; l. hand was grasping a small lion of which l. forepaw and hind paw are preserved on statuette's l. thigh; dressed in a short, unfolded chiton, painted red; sleeves ending at elbows; lion-skin hanging over both shoulders, its hind paws falling down the thighs; the forepaws knotted on the breast; girdle around waist. Feet, l. leg up to the knee, head, r. arm, l. hand, and most of lion missing; l. knee broken. White limestone, slightly yellow. Height 29.0. Shoulder width 13.2. Waist width 7.2. Deposit of sculptures. 77.9.
116. Fragment of plank-shaped torso. White limestone. Height 15.0. Deposit of sculptures. 79.3.
117. Statuette, as No. 218-178, but with rather carefully sculptured ears; mouth less smiling; body and face less vigorously sculptured and body flatter, shoulders more sloping. Base and feet missing; l. hand damaged; broken at body, l. arm, and neck. White limestone. Height 70.5. Breast to back 6.0. Shoulder width 19.0. Head height 10.7. Length 7.3. Width 6.8. Deposit of sculptures. 76.0.
118. Oval head with strong chin; thin, smiling lips; nose in line with forehead; almond-shaped eyes; wreath around head; hair rendered by radiating grooves ending in simple curls over forehead; short hair at back of head; ears visible. Traces of red colour on wreath. R. side broken but repaired. White limestone. Total height 11.7. Head height 10.3. Length 9.1. Width 6.0. Deposit of sculptures. 87.0.
119. Fragment of plank-shaped statuette; much damaged; worn. White limestone. Length 40.0. Deposit of sculptures 76.5.
120. Breast part of statuette; damaged. White limestone. Height 19.0. Deposit of sculptures. 78.0.
121. Lower part of statuette with l. foot advanced; l. arm vertical, attached to body; closed hand. R. part of lower body and upper part of body missing. White limestone, slightly burnt. Length 25.0. Deposit of sculptures. 77.0.

122. Fragment of r. arm with closed hand. White limestone, slightly burnt. Length 11.0. Deposit of sculptures. 78.0.
- 123-128. Lower part of r. arm with closed hand (No. 128) holding fragment of club. White limestone. Length 22.0. Deposit of sculptures. 78.0.
124. Fragment of plank-shaped statuette with both arms vertical; folds of himation rendered by oblique, rough grooves on lower part of fragment. Lower part of body, arms, and head missing. White limestone. Length 18.0. Deposit of sculptures. 76.0.
125. Oval head with rounded chin; a faint smile on the rather thick lips; nose in line with forehead; eyes of myrtle-leaf shape; short, conical cap on head with elongated top; two rows of curls over forehead, the curls rendered by rough notchings; roughly shaped ears. Top of cap missing; l. side of cheek and neck damaged. White limestone. Total height 10.0. Head height 5.4. Length 4.8. Deposit of sculptures. 76.1.
126. Fragment of statuette; face, feet, and part of lower body preserved; r. foot slightly advanced; shoes painted red. White limestone. Length 12.0. Deposit of sculptures. 76.0.
127. Base and feet of statuette; worn. White limestone. Length 10.0. Deposit of sculptures. 76.0.
128. Hand, belonging to No. 123. Deposit of sculptures. 79.3.
129. Hand holding part of club. White limestone. Length 5.0. Deposit of sculptures. 79.0.
130. Herakles' head, ovoid in shape with strong chin; cheeks with marked muscles at either side of the root of nose; slightly curved, prominent nose; almond-shaped eyes with thick lids; thin, feathered eyebrows; slightly smiling mouth with protruding lips; wide, bulging forehead; short hair over forehead hanging down in stripes rendered by oblique, curved grooves; lion-skin over head with sculptured eyes, lids, and nostrils, leaving ears of Herakles visible; part of the club along the back of head. Chin and top of nose chipped; part of upper lip missing. White limestone with yellow patina. Total height 10.5. Head height 7.5. Length 6.4. Width 5.7. Deposit of sculptures. 76.0.
- 131-446. Statuette of Herakles standing on a base (No. 446), with l. leg slightly advanced; feet (No. 446) wearing plain shoes with marked soles; straight, rather plank-shaped body, r. arm raised, its hand holding club (now missing); the club has been fixed to the back of head; l. arm bent along side of body, its forearm free from body; hand holding small lion by its r. ear; lion's mane marked by incised chequers; lion-skin over the head, its forepaws knotted on the breast, hind paws falling along legs; wearing a chiton ending above knees, surface marked by incised chequers, girdle around waist. Traces of red on chiton. Parts of r. and l. leg, r. hand with club, and face missing; broken at knees, ankles, neck, r. upper arm, and l. arm. White limestone. Height 60.0 (base included). Head height 7.5. Feet to hips 29.0. Shoulder width 20.0. Waist width 10.8. Hips width 13.0. Deposit of sculptures. 77.8.
132. Male statuette, as No. 393-404-452, but wearing long chiton with sleeves ending at elbows; plain himation over l. shoulder. Lower part of statuette, r. hand, head, and head of buck missing. White limestone. Height 30.2. Breast to back 6.1. Shoulder width 15.2. Deposit of sculptures. 76.0.
133. Oval, short head with faintly smiling mouth; eyes of myrtle-leaf shape; plain ears; wreath around hair; curled hair over forehead and at back of head. L. cheek missing; damaged and much worn. White limestone. Total height 10.0. Head height 8.6. Length 6.4. Width 5.0. Deposit of sculptures. 77.0.
134. Fragment of a statuette with plank-shaped body; folded chiton or himation; r. arm vertical, l. arm bent holding buck (?). White limestone, much worn and damaged. Height 37.0. Breast to back 4.5. Shoulder width 14.1. Deposit of sculptures. 76.0.
135. Fragment of a statuette with plank-shaped body; both arms vertical along sides of body; l. hand holding bird; oblique shoulders; long chiton with vertical, grooved folds; girdle at waist; himation over both shoulders with grooved folds and borders painted red. Lower part of statuette with part of bird and head missing. White limestone. Height 21.7. Breast to back 3.2. Width 11.7. Deposit of sculptures. 79.5.
- 136-276. Male statuette, as No. 393+404+452, but more roughly cut. R. forearm and head missing. Surface much worn. Traces of yellow colour on chiton and red colour on feet. White limestone. Height 60.5. Shoulder width 15.0. Deposit of sculptures. 76.0.
137. Male statuette, as No. 28. R. upper arm, part of r. side of body, and head missing; much worn and damaged. White limestone with greyish surface. Height 46.2. Breast to back 4.9. Shoulder width 11.8. Deposit of sculptures. 76.0.
138. Head with rounded face; short in profile; almost straight mouth; almond-shaped eyes with lids; wreath around head; hair on head rendered by grooves ending in notched curls over forehead. Damaged on cheeks, nose, and mouth; r. side of back of head missing. White limestone. Total height 12.0. Head height 9.3. Length 7.2. Width 6.3. Deposit of sculptures. 79.5.
- 139-256+449. Male statuette, full-bodied (body = No. 139), with l. leg well advanced; both legs straight; r. arm is bent and uplifted, the upper arm horizontal in line with shoulder; the r. hand holding a spear of which only a small part is preserved (No. 449); l. arm bent and well advanced with elbow free from body, its hand closed; once holding an object, possibly a bird; straight neck; oval head (No. 256) with pointed, rounded beard, starting from the hair below the temples, the curls rendered by four rows of short, parallel, incised lines;

- slightly smiling mouth; rounded cheeks; prominent nose in line with slightly sloping forehead, eyes of myrtle-leaf shape with lids; curved eyebrows; two rows of cork-screw-shaped curls across forehead; on crown of head the hair is rendered by radiating grooves and falls down at back of head and along sides of neck; a band with circular section around head and from this a flat band in which a hair-roll at the back of head is suspended; long, folded chiton with overfold, the folds rendered by shallow, narrow grooves; girdle at waist; a folded shawl with rounded outline over both shoulders over breast and down the back, the folds rendered by wide grooves. Traces of red on lips. Base, feet, part of legs, and chiton missing. The head is made separately and fixed to the body by means of a peg which is inserted in two corresponding holes, one in the neck and one in the body. White limestone. Height 56.0. Legs to hips 28.0. Legs to knees 13.4. Shoulder width 18.0. Waist width 10.0. Hips width 11.2. Head height 9.5. Length 9.0. Width 6.2. Deposit of sculptures 76.0.
140. Fragment of a torso belonging to No. 143. Deposit of sculptures. 76.5.
- 141 + 167 + 170 + 175 + 207 + 220 + 317 + 331.
Statue of Herakles standing on a trapezoid base with naked feet (No. 175); long toes; l. leg advanced (No. 170); rather plank-shaped body (No. 141); curved breast-line; r. arm raised (Nos. 317, 331), its hand grasping a short club; l. arm (No. 167) bent and slightly advanced, its hand (No. 207) grasping the tail of a lion of which fragments are preserved above l. knee; short neck; oval head with full cheeks; strong, rounded chin; smiling lips; nose in line with forehead (restored in gypsum); almond-shaped eyes with lids; rather carefully sculptured ears; a row of curls over the forehead; lion-skin on head with carefully sculptured ears and eyes, falling down back of body, its hind paws hanging along the thighs, its tail hanging along r. leg down to tibia; the forepaws knotted on the breast; wearing short, unfolded chiton with short sleeves and a girdle around waist. Fragment of club still attached to back of head and painted red. Broken at l. foot, ankles, l. leg below knee, knees, r. elbow and forearm, l. shoulder, elbow, and forearm; part of nose, l. eye, club, and lion missing. White limestone. Height 123.0 (base included). Legs to hips 69.0. Shoulder width 30.0. Waist width 16.5. Hips width 19.4. Head height 18.0. Width 12.0. Deposit of sculptures. 76.0.
142. L. leg, belonging to No. 53. Deposit of sculptures In the filling.
- 143 - 140.
Torso of male statue with slender, plank-shaped body, standing on a small base; both arms vertical along the sides of body; the r. hand holding a small, circular object; the l. a bird (now damaged); wearing a long chiton reaching down to feet with vertical folds; himation over l. shoulder falling in zigzag folds over breast, oblique folds over body, and a wide, vertical fold ending at knees, shoes painted red and red borders on himation. The dress is very close to body leaving its slender shape visible. Part of l. arm, r. shoulder, and head missing; surface much worn. White limestone. Height 142.0. Breast to back 15.0. Shoulder width 39.0. Waist width 22.0. Hips width c. 27.0. Deposit of sculptures. 76.0.
- 144 + 237.
Male statuette with plank-shaped body, standing on a small, square base with l. leg advanced; r. arm lifted in the pose of adoration; l. arm slightly bent along side of body, its hand holding bird by the wings; oval head with sharply defined chin; prominent cheeks; rather prominent nose in line with sloping forehead; smiling mouth; almond-shaped eyes; hair over forehead rendered by oblique, parallel, curved grooves; wreath around head; short hair at back of head; wearing long, plain chiton reaching down to feet; himation over l. shoulder with vertical, flat folds along body, between the legs, and ending in a zigzag fold at knees; shoes painted red. Both hands and part of r. side of head missing. White limestone. Height 56.2. Breast to back 6.0. Shoulder width 13.8. Head height 8.0. Length 7.2. Deposit of sculptures 76.0.
145. L. leg, belonging to No. 19. Deposit of sculptures. 71.9.
146. L. leg of statuette. White limestone. Length 12.5. Deposit of sculptures 81.0.
147. Fragment of plank-shaped body; broken. Grey limestone. Height 22.0. Belly to back 4.1. Shoulder width 11.2. Deposit of sculptures. 79.5.
148. Fragment of torso of plank-shaped statuette, folds of himation rendered by vertical grooves along l. side and oblique, curved grooves across body. White limestone. Length 20.0. Deposit of sculptures 79.0.
149. Statuette with plank-shaped body; concave sides; both arms bent over breast; hands holding double flute; dressed in chiton with very short sleeves. Lower part of body, part of l. side, part of r. shoulder, and head missing. White limestone. Height 16.0. Deposit of sculptures. 78.5.
150. Fragment of plank-shaped statuette; much worn. White limestone. Height 35.0. Deposit of sculptures. 79.8.
151. Part of l. foot with roughly sculptured toes, back part of foot missing. White limestone. Length 7.0. Deposit of sculptures. 80.3.
152. Lower part of plank-shaped statuette. White limestone. Height 11.0. Deposit of sculptures 80.0.
153. Fragments of plank-shaped statuette; much damaged. White limestone. Height 25.0. Deposit of sculptures. 78.1.
154. Head, belonging to No. 188. Deposit of sculptures. 80.5.
155. Fragment of statuette; base, feet and part of lower body preserved; feet almost isolar but diverging. Lower part of body chipped. White limestone. Length 24.0. Deposit of sculptures. 78.5.
156. Fragment of statuette, belonging to No. 173. Deposit of sculptures 77.5.

157. Oval head with sharply defined chin; slightly smiling mouth; flattened cheeks; large eyes of myrtle-leaf shape, long, prominent nose in line with forehead; rather carefully sculptured ears; short hair at back of head; three rows of curled hair over forehead, the curls rendered by triangular notchings, hair on top of head rendered by radiating grooves; wreath around head. Top of nose slightly chipped. White limestone. Total height 12.4. Head height 11.3. Length 10.0. Width 7.2. Deposit of sculptures. 77.5.
158. Fragment of plank-shaped statuette with l. foot advanced; part of lower body and upper body missing. Chipped surface. White limestone. Height 33.0. Deposit of sculptures. 76.5.
159. Male statuette with plank-shaped body; r. foot advanced; l. arm along side of body, slightly advanced, holding small object; wearing long chiton with sleeves ending at elbows; himation wrapped around body with thin, oblique folds and a vertical zigzag fold with red border along l. side of body. Feet, l. hand, r. arm, and upper part of statuette from breast missing. White limestone. Height 48.0. Front to back 8.0. Width of body 15.3. Deposit of sculptures 76.0.
160. Head, belonging to No. 41. Deposit of sculptures. 76.0.
161. Fragment of statuette; much damaged. White limestone. Height 24.0. Deposit of sculptures. 77.6.
- 162—217.
Male statuette, as No. 136—276. Upper part damaged; head and parts of body missing; surface much worn; no traces of colours. White limestone. Height 55.2. Breast to back 6.6. Deposit of sculptures 76.5.
163. Torso of a Herakles, belonging to No. 53. Deposit of sculptures. 76.3.
164. Base and r. foot, belonging to No. 10. Deposit of sculptures 76.1.
165. Base and feet of statuette; l. foot slightly advanced; shoes painted red. White limestone. Length 22.0. Deposit of sculptures. 76.0.
166. Oval head with strong, rounded chin; slightly smiling mouth placed immediately below the nose; nose and forehead forming a convex line; large eyes of myrtle-leaf shape; plain ears; short, conical cap with elongated top; hair falling in concave side-curls along sides of neck. Red colour on cap. White limestone. Total height 13.2. Head height 6.4. Length 4.8. Width 5.4. Deposit of sculptures 76.9.
167. Fragment of l. arm, belonging to No. 141. Deposit of sculptures. 76.2.
168. Fragment of torso of plank-shaped statuette; worn and damaged. White limestone. Length 12.0. Deposit of sculptures. 78.0.
- 169—229
Male statuette with plank-shaped body, widening upwards, with l. foot advanced; both arms vertical along the sides of body; l. hand holding U-shaped lyre; wearing chiton with sleeves ending at elbows; himation over l. shoulder with a vertical, wide fold along the body.
- Parts of feet, both hands, and head missing; much worn. White limestone. Height 30.5. Breast to back 4.6. Shoulder width 9.1. Deposit of sculptures 77.5.
170. L. leg, belonging to No. 141. Deposit of sculptures 77.3. 171—420.
Statuette of Herakles with straight, slender body; l. leg slightly advanced; l. arm slightly bent along the side of body, its hand grasping the head of a small lion looking aside; oval, rather narrow head (No. 171); wearing a chiton with short sleeves; the lion-skin covers the head and falls along the back, its forepaws knotted on breast; a row of curls at both sides of head. Feet, legs up to knees, r. arm and hand holding club missing; surface much worn. Yellowish limestone. Height 39.5. Shoulder width 15.0. Waist width 8.7. Deposit of sculptures 77.0.
172. Fragment of plank-shaped statuette; l. arm vertical, attached to body; hand closed; upper part of body, r. arm, and lower part of body missing. White limestone. Length 19.5. Deposit of sculptures 77.3. 173—156.
Statuette of Herakles with l. leg advanced, l. knee bent; muscles of legs strongly marked; r. arm raised (now missing); l. arm bent along side of body, its forearm free from body; l. hand grasping the tail of a small lion; wearing a chiton ending above knees, with short sleeves; the forepaws of lion-skin are knotted on the breast; hind paws hanging along the sides of body; girdle around waist. Feet, r. arm, and head missing; surface worn. White limestone. Height 41.5. Shoulder width 17.0. Waist width 9.0. Hips width 10.0. Deposit of sculptures. 79.1.
174. Fragment of plank-shaped statuette; part of torso preserved; worn. White limestone. Length 14.0. Deposit of sculptures. 78.5.
175. Base and feet, belonging to No. 141. Deposit of sculptures 77.7.
176. Fragment of plank-shaped statuette; base, feet, and part of lower body preserved; feet isolar. White limestone. Length 7.2. Deposit of sculptures. 77.7.
177. Fragment of head; only part of back of head preserved with short, parted hair. White limestone. Height 9.1. Width 6.1. Deposit of sculptures 77.7.
178. Head, belonging to No. 218. Deposit of sculptures 78.2.
179. Fragment of plank-shaped statuette; part of torso preserved. White limestone. Length 19.0. Deposit of sculptures 78.5.
180. Base and feet of statuette; l. foot advanced. White limestone. Length 24.0. Deposit of sculptures. 78.3.
181. Base and feet of statuette. White limestone. Length 19.0. Deposit of sculptures 79.3.
182. Lower part of statuette with base, belonging to No. 62. Deposit of sculptures. 77.7.
183. Fragments of statuette; much damaged. White limestone. Deposit of sculptures. 78.5.
184. Fragment of statuette; only piece of l. part of torso preserved; much worn; damaged. White limestone. Length 35.0. Deposit of sculptures. 78.2.

185. Fragment of lower part of statuette. White limestone. Length 2.4. Deposit of sculptures. 79.0.
186. Oval head with prominent chin and nose; nose-line forming obtuse angle with almost straight forehead; small mouth slightly smiling; large, prominent eyes of half-moon shape; hair falling in wig-shaped mass at back of head and covered by a veil leaving the ears visible; crown of head flattened. White limestone; surface much worn. Total height 11.0. Head height 8.7 Length 6.1. Width 5.3. Deposit of sculptures 76.0.
187. Small, oval head with rounded chin; faintly smiling mouth; straight nose; eyes of myrtle-leaf shape; hair covered by a veil falling down back of head leaving the plain, disc-shaped ears visible. Worn. White limestone, slightly burnt. Height 7.4. Width 3.6. Deposit of sculptures. 78.5.
- 188-154.
Male statuette with plank-shaped body; r. arm vertical along side of body, with closed hand; l. arm bent, holding a buck close to the side; its hand holding the forelegs; sloping shoulders; oval head (No. 154) with rounded cheeks; nose in line with forehead; eyes of myrtle-leaf shape; roughly cut ears; wreath on head; two rows of curls over forehead rendered by short, parallel cuttings; hair on crown of head rendered by parallel grooves and falling in two plain plaits behind the ears; wears an Egyptian kilt with plain girdle around waist. Legs up to thighs, l. arm, chin with mouth missing; broken. White limestone. Height 41.0. Breast to back 4.3. Shoulder width 14.0 Head height 11.0. Deposit of sculptures. 77.5.
189. Male statuette, as No. 132. Lower part from knees, head, and head of buck missing. Height 14.5. Breast to back 4.5. Shoulder width 10.9. Deposit of sculptures. 78.5.
190. Fragment of plank-shaped statuette; base, feet, part of lower body preserved; feet isolinear peeping out of plain chiton and resting on small base tablet; toes marked by rough grooves; border of himation painted red. White limestone, burnt. Height 12.5. Deposit of sculptures. 79.3.
191. R. leg belonging to No. 33. Deposit of sculptures. 79.0.
192. L. leg of statuette. White limestone. Length 13.0. Deposit of sculptures. 78.5.
193. Head, belonging to No. 56. Deposit of sculptures. 77.3.
194. Oval head with rounded chin and cheeks; slightly smiling mouth; nose in line with forehead; eyes of myrtle-leaf shape with lids; wreath around head, hair rendered by grooves radiating from crown of head and falling back, leaving the roughly cut ears visible; on forehead cork-screw curls. Nose and r. eye chipped. White limestone. Total height 11.0. Head height 8.9 Length 6.0. Width 5.3. Deposit of sculptures. 77.7.
195. Fragment of plank-shaped statuette. White limestone. Height 7.0. Deposit of sculptures. 78.7.
196. Depressed globular bead of glass paste, covered by dark glaze with incrustation of white circles; pierced by a hole in the middle Diam. 1.0. Deposit of sculptures. 77.5.
197. Male statuette, as No. 28, but with roughly shaved surface; chiton with short sleeves. Feet and head missing. Height 28.6. Breast to back 3.4. Shoulder width 10.7. Deposit of sculptures. 77.5.
198. Fragment of a plank-shaped statuette; l. arm vertical; r. arm bent over breast and slung in a fold of plain himation; hand closed; lower part of body, lower part of l. arm, and head missing. White limestone. Length 21.5. Deposit of sculptures. 76.2.
199. Fragment of statuette; only breast preserved; chipped and much damaged. White limestone. Length 20.0. Deposit of sculptures. 79.0.
200. Lower part of plank-shaped statuette; l. leg slightly advanced; part of feet missing; much damaged. White limestone Height 28.0. Deposit of sculptures. 78.1.
201. Base and feet of statuette; l. foot advanced; only traces of l. foot preserved; part of r. foot missing. White limestone. Length 15.0. Deposit of sculptures. 76.9.
- 202-35.
Male statuette, same position as No. 251-14, but with folded chiton and himation with oblique folds over breast and a vertical fold along l. side of body; borders of himation painted red. R. hand, l. shoulder, and head missing. White limestone. Height 52.5. Breast to back 5.1 Deposit of sculptures. 77.5.
203. Fragment of plank-shaped statuette. White limestone; worn. Length 29.0. Deposit of sculptures. 77.7.
- 204-208.
Statuette of Herakles with very short legs of uniform thickness; l. leg advanced; roughly cut, straight body with well marked breast; r. arm lifted (now missing); l. arm bent and its hand holding a small lion by its tail. The statuette is dressed in a short, girdled chiton with overfold, ending above knees; it stands on a narrow base tablet. Head and r. arm missing. (R. leg = No. 208). Height 32.8. Shoulder width 15.0. Deposit of sculptures. 77.5.
205. Hand, belonging to No. 32. Deposit of sculptures. 78.1.
206. Male statuette with plank-shaped body; vertical arms along sides of body; sloping, rounded shoulders; oval head; prominent chin; slightly smiling mouth; eyes of myrtle-leaf shape; curved nose; nose and forehead forming a convex line; plain ears; the hair in front is rendered by oblique, shallow notchings and is wrapped up in a veil; falling in a compact mass at back of head down to shoulders; plain chiton and himation, the latter falling over l. shoulder; lips and himation painted red. Lower part of statuette, hands, and l. arm missing; broken at neck. White limestone. Height 25.2. Shoulder width 12.0. Breast to back 3.9 Head height 7.0. Width 4.3. Deposit of sculptures. 76.5.
207. Hand, belonging to No. 141. Deposit of sculptures. 76.5.
208. R. leg, belonging to No. 204. Length 23.0. Deposit of sculptures 76.5.
209. Stele of limestone, rectangular; square in section; rect-

- angular, moulded base. Height 77.0. Deposit of sculptures 77.5.
- 210 Base, feet, and lower part of plank-shaped body; l foot advanced; shoes painted red. White limestone. Length 15.0. Deposit of sculptures. 77.2.
211. Fragment of plank-shaped torso, folds of chiton and mantle rendered by vertical grooves, mantle with overfold and flap along r. side. White limestone. Height 11.0. Deposit of sculptures 77.5
212. Fragment of statuette; base, isolinear feet, and lower part of body preserved. Surface much worn. White limestone. Height 15.0. Deposit of sculptures. 79.0.
213. Base and l. foot, belonging to No. 33. Deposit of sculptures. 79.0.
- 214-529.
Lower part of statuette, standing on a small base, with l. foot slightly advanced, wearing a long chiton with vertical, grooved folds and himation with one vertical, flat fold and smaller, oblique, grooved folds. White limestone. Height 31.8. Front to back 6.0. Deposit of sculptures. 78.0.
- 215 Base, feet, and part of lower body of plank-shaped statuette; l. foot slightly advanced; shoes painted red. White limestone. Height 8.5. Deposit of sculptures. 77.8
216. Fragment of plank-shaped torso; zigzag folds of himation along l. side; folds across body rendered by curved, oblique lines; much worn. White limestone. Height 25.5. Deposit of sculptures. 78.0
217. Fragment of a statuette, belonging to No. 162. Deposit of sculptures. 79.5.
- 218-178.
Male statuette with plank-shaped body, narrowing towards the base; standing on a small base with l. foot advanced; almost vertical arms with closed hands along sides of body; sloping shoulders; upper part of breast flat with a marked ridge between upper and lower part; oval head (No. 178); strong chin; prominent cheeks; large, wide eyes of myrtle-leaf shape; marked eyebrow line; long nose in line with sloping forehead; plain ears; hair covered by a veil with a row of curls over forehead, the curls rendered by parallel, vertical cuttings, plain hair falling in a compact mass at back of head to shoulders. L. hand partly missing; traces of soot at base. White limestone. Height 43.5. Breast to back 4.7. Shoulder width 13.5. Head height 9.0. Length 5.5. Width 6.2. Deposit of sculptures 78.0
219. Oval head with strong chin; long nose in line with short forehead, slightly smiling mouth; full, rather slack cheeks; eyes of myrtle-leaf shape; large, sculptured ears; wreath around head; hair on crown of head rendered by grooves ending in thick, parallel stripes over forehead, plain, long hair at back of head. White limestone. Total height 12.2. Head height 9.3. Length 8.5. Width 5.2. Deposit of sculptures 77.8
- 220 R. leg belonging to No. 141. Deposit of sculptures 78.0
- 221-297-300.
Male statuette, as No. 28, but more plank-shaped. Feet, head, and part of r. arm missing, worn. Height 49.1. Breast to back 3.5. Shoulder width 10.0. Deposit of sculptures 78.0
- 222-282.
Upper part of statuette with plank-shaped body; vertical arms along sides of body; sloping shoulders; long neck; small head with conical helmet (No. 282); wearing chiton and himation over l. shoulder. Lower part missing, face completely worn off; broken at neck. Parts slightly burnt. White limestone. Height 23.0. Shoulder width 7.0. Deposit of sculptures. 78.0.
223. Statuette of a seated so-called temple-boy, as No. 359, but with r. arm vertical, its hand holds some object which stands on the ground; l. arm bent over body; himation over both shoulders knotted on the breast; flat back side. Part of base, l. hand, and head missing. White limestone, burnt at l. side. Height 18.5. Breast to back 5.2. Shoulder width c. 11.0. Deposit of sculptures 78.0.
- 224 Oval head with strong chin; rounded cheeks; slightly smiling mouth; nose in line with forehead; eyes of myrtle-leaf shape; one row of curls rendered by notchings over the forehead; plain diadem around head; long hair at back of head; hair on head may be covered by a veil. Nose and l. part of chin damaged. White limestone. Total height 10.5. Head height 7.7. Length 5.4. Width 4.9. Deposit of sculptures. 77.9.
225. Fragments of a Herakles statuette, much damaged and worn. White limestone. Deposit of sculptures. 77.7.
226. Fragment of plank-shaped torso; much chipped and worn. White limestone. Height 58.0. Deposit of sculptures. 79.3.
227. Fragment of a male statuette with plank-shaped body; l. arm vertical; r. arm bent across chest; plain chiton and himation over both shoulders. Traces of red colour on chiton and himation on breast. Lower part, l. arm, and head missing; much worn. White limestone. Height 20.0. Breast to back 4.2. Shoulder width 10.7. Deposit of sculptures 79.3.
228. Base and feet of statuette; l. foot advanced; traces of red paint on shoes. White limestone. Length 19.8. Deposit of sculptures 78.0.
- 229 Upper part of statuette, belonging to No. 160. Deposit of sculptures 77.5.
230. Lower part of plank-shaped statuette; l. foot slightly advanced; shoes painted red. At the r. side of statuette hind part of animal whose hind legs rest on the same base as feet of statuette; lower part of forelegs preserved, attached to body of fragment. Parts missing. White limestone. Height 14.0. Deposit of sculptures. 78.0.
231. Head, belonging to No. 75. Deposit of sculptures 78.0.
232. Lower part of r. arm and hand with sculptured fingers and nails, thumb missing. Arm has been held in position of adoration. White limestone. Length 30.0. Deposit of sculptures 78.0
- 233 Fragment of statuette with plank-shaped body; bulging

- breast; vertical arms along sides; wearing long chiton with sleeves ending at elbows. Lower part, hands, and head missing. Grey limestone. Height 22.5. Breast to back 4.8. Shoulder width 11.6. Deposit of sculptures. 78.1.
- 234+250. Statuette of Herakles in frontal position with evenly curved breast line; r. arm lifted (now missing), holding club; r. arm probably vertical with hand holding a now missing object of which remains are preserved on the l. thigh; oval head (No. 250) with full cheeks; slightly smiling lips; almond-shaped eyes without lids; the short hair, which hides the ears, is rendered by curls over forehead; plain band around head; part of club at back of head preserved; dressed in a chiton ending at knees; a tied girdle around waist. Feet, r. leg up to knee, l. leg up to hip, and both arms missing; nose and lips chipped; oblique scratchings on breast; worn and carelessly cut. White limestone. Height 35.0. Shoulder width 13.6. Waist width 8.0. Head height 8.0. Length 5.5. Width 5.0. Deposit of sculptures. 78.0.
235. Upper part of female statuette with prominent breasts; l. arm slightly advanced, partly free from body, its hand holding fold of himation; bracelet on arm; broad neck; oval head with flat crown; prominent chin and cheeks; smiling, protruding lips; nose in line with forehead; eyes of myrtle-leaf shape; sculptured ears with large, circular earrings decorated with central knob from which radiate five incised lines; necklace rather high up around the neck; plain diadem around head; hair falling over forehead in contiguous plaits rendered by vertical lines and horizontal notchings; long hair at back of head rendered in the same way and three plaits falling along sides of neck down the breast, on either side; veil on head rendered by latticed, incised lines; wearing plain, thin chiton with sleeves ending at elbows; folded himation over r. shoulder with oblique and vertical folds over body. R. side with r. shoulder, most part of l. hand, part of head, and lower part of statuette missing. White limestone. Height 36.0. Shoulder width c. 16.0. Head height 9.5. Length 8.3. Width 6.9. Deposit of sculptures. 78.0.
236. Statuette of Herakles, standing on an irregular base with l. leg advanced and r. leg straight; straight, rather slim body; r. arm raised, holding short club which is attached to back of head; l. arm bent, its hand probably once holding a small lion of which only small fragments preserved on l. thigh; oval head; soft cheeks and chin; slightly smiling lips; nose in a line with the slightly sloping forehead; eyes of myrtle-leaf shape, without lids; plain, roughly cut ears; three rows of notched curls over the forehead coming out from lion-skin which covers the head and falls along the back, its hind paws along the legs and its tail down to base; its forepaws knotted on breast; dressed in a chiton over both shoulders with short sleeves, decorated with incised chequers; girdle around waist. Traces of red colour on lips and chiton. L. leg from ankle to knee, part of r. upper arm, l. hand missing; broken at r. ankle and knee, r. upper arm; l. forearm damaged. White limestone. Height 56.0. Shoulder width 17.6. Breast to back 7.8. Waist width 9.5. Hips width 11.4. Head height 8.5. Length 7.5. Width 6.6. Deposit of sculptures. 78.0.
237. Upper part of statuette with head, belonging to No. 144. Deposit of sculptures. 78.5.
238. Statuette of a Herakles, standing on square base with stiff, nude feet; straight legs, slightly tapering down to the ankles; l. leg slightly advanced; straight body; r. arm lifted; l. arm slightly advanced, its hand grasping tail of small lion whose head is bent back; oval head with strong nose in line with forehead; a row of vertical curls across forehead; lion-skin covering head, its forepaws knotted on breast; short, plain chiton with sleeves ending at elbows; the skin is tied by a girdle. Head and body much worn. R. forearm and hand with club missing. Soft, white limestone. Height 55.4. Feet to hips 29.0. Shoulder width 17.2. Waist width 9.6. Head height 6.7. Length 7.2. Width 5.2. Deposit of sculptures. 78.7.
239. Oval head with slightly curved neck; prominent, rounded chin; slightly open, smiling lips; rounded cheeks; almond-shaped eyes with lids and prominent eyeballs; short hair rendered by incised zigzag notchings all over the head; carefully cut ears. Nose and back part of neck missing; l. side of face badly damaged. Total height 22.5. Head height 17.0. Width 11.4. Deposit of sculptures. 80.3.
240. R. leg of statuette. White limestone. Length 14.5. Deposit of sculptures. 78.5.
241. Fragment of r. arm, belonging to No. 53. Deposit of sculptures. 79.2.
- 242-253+284. Male statuette with plank-shaped body, standing on small base with l. foot slightly advanced; r. arm lifted in pose of adoration; l. arm vertical along side of body, holding bird; sloping shoulders; short, thick neck; oval head (No. 253) with rounded chin and cheeks; slightly smiling, protruding mouth; nose in line with forehead; one row of hair over forehead, the curls rendered by vertical, parallel cuttings; wreath around head; short hair at back of head; wearing plain chiton with sleeves ending at elbows; himation over l. shoulder with one vertical fold along body between legs and ending below knees with red borders; red colour on shoes. Part of feet, l. hand and part of bird, fingers of r. hand missing. White limestone. Height 65.5. Breast to back 6.2. Shoulder width 18.2. Head height 10.0. Length 7.8. Width 6.3. Deposit of sculptures. 79.0.
243. Part of base and l. foot of statuette; shoe painted red. White limestone. Height 22.0. Deposit of sculptures. 78.0.
244. Head of statuette: hair falling in compact mass at back of head; face much worn. White limestone. Height 14.0. Deposit of sculptures. 79.0.

- 245-410.
Statuette with body slightly narrowing downwards and oval in section; standing on a small base with naked, isolar feet; both arms bent over breast; hands holding double flute; the statuette seems to be wearing chiton and himation. Part of flute and head missing; worn. White limestone. Height 37.0. Belly to back 6.0. Shoulder width 12.6. Deposit of sculptures. 78.3.
- 246-573.
Male statuette with plank-shaped body; l. leg slightly advanced; r. arm vertical; l. arm bent, holding conventionalized buck at side of body; sloping shoulders; oval head (No. 573) with long, rounded chin; slightly smiling, protruding lips; nose in line with forehead; almond-shaped eyes with vaguely indicated lids; four rows of curls over forehead; diadem around head consisting of vertical, raised plaques with rounded tops; long chiton with folds marked by vertical, shallow grooves; himation over l. shoulder, with oblique, grooved folds across body and vertical, flat ones along body between legs. Legs up to knees, r. arm from elbow, and l. hand missing; nose of buck damaged. White limestone. Height 52.5. Breast to back 5.6. Shoulder width 15.1. Head height 10.4. Length 7.5. Width 6.5. Deposit of sculptures. 82.1.
247. Fragment, belonging to No. 114. Height 26.0. Deposit of sculptures. 78.5.
248. Fragment of plank-shaped statuette. White limestone. Height 28.0. Deposit of sculptures. 78.0.
249. Fragment, as No. 247. Deposit of sculptures 81.0.
250. Head, belonging to No. 234. Deposit of sculptures. 78.5.
- 251-14.
Male statuette with plank-shaped body, standing on small, square base with l. foot slightly advanced; r. arm lifted in pose of adoration; l. arm vertical along the side of body, slightly advanced, its hand holding bird by both wings; oval head (No. 14); slightly smiling, protruding lips, rounded chin and cheeks; nose in line with forehead; three rows of curled hair over forehead; veil on head; long hair falling in a compact mass at back of head; wearing long, plain chiton; plain himation over l. shoulder falling down to knees; red borders on himation; red on shoes. Fingers of r. hand and part of r. side of head missing; face and breast worn. White limestone. Height 65.7. Breast to back 7.0. Shoulder width 17.3. Head height 11.0. Length 7.0. Width 6.8. Deposit of sculptures 77.7.
252. Base and feet of statuette; l. foot advanced; part of l. foot and base missing; traces of red paint on shoes. White limestone. Length 22.0. Deposit of sculptures. 77.8.
253. Head, belonging to No. 242. Deposit of sculptures. 77.7.
- 254-350
Male statuette, rather full-bodied, with back almost flat; frontal position; l. leg advanced; almost vertical arms along sides of body with closed hands; sloping shoulders; oval head (No. 350) with softly rounded, but well defined chin and cheeks; a faint smile on lips; prominent nose in a line with sloping forehead; narrow eyes of myrtle-leaf shape with lids; carefully sculptured ears; the hair is rendered by parallel, shallow grooves and falls in a compact mass at back of head; it is covered by a veil; plain chiton ending at knees with sleeves ending at elbows; plain girdle around waist. Traces of red colour on chiton. Legs up to knees and part of back of head missing, the latter restored in gypsum. White limestone. Height 46.5. Length of l. arm, hand included 25.5. Shoulder width 16.5. Waist width 10.0. Hips width 11.2. Breast to back 7.6. Head height 9.6. Length 7.5. Width 5.8. Deposit of sculptures. 77.7.
- 255-379.
Male statuette with plank-shaped body, standing with l. foot advanced on roughly square base (feet and base = No. 379); l. arm bent and advanced; wearing long chiton down to feet; himation with oblique folds over body and vertical folds ending with zigzag folds at left side of body from below l. arm. Red shoes. R. arm, l. forearm, neck, head, and parts of base missing; breast much worn. White limestone. Height 40.2. Breast to back 4.8. Width below shoulder 10.6. Deposit of sculptures. 79.7.
256. Head, belonging to No. 139. Deposit of sculptures. 76.7.
257. Upper part of plank-shaped statuette with almost vertical arms along sides of body; sloping shoulders; thick neck; oval head with wide chin, and rounded cheeks; slightly smiling mouth; nose in line with forehead; eyes of myrtle-leaf shape, without lids; plain ears; conical cap; plain hair falling in a compact mass at back of head down to shoulders; wearing a chiton with sleeves ending at elbows and a himation over l. shoulder with marked edge. Faint traces of red on himation; lips red. Lower part of body and top of cap missing; nose damaged. White limestone. Height 28.0. Breast to back 5.5. Shoulder width 14.2. Head height 7.5. Length 4.5. Width 5.2. Deposit of sculptures. 77.7.
258. Torso of Herakles with slender body; l. leg advanced; r. arm was raised (now missing), l. hand was grasping a small lion by its tail; lion's head turned back; short, unfolded chiton under the lion-skin; a girdle around waist. Feet, legs up to knees, head, arms, and part of lion's head missing. White limestone. Height 25.5. Waist width 7.9. Deposit of sculptures. 77.7.
259. Fragment of plank-shaped torso. White limestone. Height 30.0. Deposit of sculptures. 78.7.
260. Statuette of Herakles, standing on a roughly trapezoid base tablet with naked feet without marked toes; l. leg slightly advanced; body straight and plank-shaped; r. arm raised; l. arm slightly bent along side of body, its hand grasping tail of small lion whose head is bent back, wearing a folded chiton ending at knees with short, folded sleeves, the folds rendered by vertical, parallel grooves; in front, below waist, horizontal folds

- ending with a small, rounded flap; the forepaws of the lion-skin are knotted on the breast; only the r. hind paw is visible at r. knee; tail falling straight down to base; girdle around base. R. forearm and head missing. White limestone. Height 55.0. Belly to back 5.5. Shoulder width 9.0. Waist width 11.0. Deposit of sculptures. 78.0.
261. Fragment of a male statuette with plank-shaped body; both arms bent over breast holding double flute with both hands; wearing long chiton with short sleeves. Lower part of statuette, head, and piece of flute missing; lower part of fragment burnt. Grey limestone. Height 22.5. Shoulder width 8.4. Deposit of sculptures. 78.1.
262. Lower part of plank-shaped statuette; l. leg slightly advanced; shoes painted red; chiton with vertical folds rendered by careless grooves; himation with vertical folds draped along l. leg; curved, oblique grooves across r. part of body. Part of feet and upper part of body missing. White limestone; worn. Height 34.0. Deposit of sculptures. 78.2.
263. Torso of Herakles with l. leg advanced; r. arm lifted (now missing); wearing a short chiton ending above knees; over the chiton the lion-skin is hanging; its forepaws knotted on breast; its hind paws falling down along the legs; girdle around waist. Traces of red on chiton. Feet, legs up to knees, head, neck, both arms, and part of the back missing; broken at waist. White limestone. Height 32.5. Waist width 10.6. Hips width 12.8. Deposit of sculptures. 78.7.
264. Fragment of a Herakles, attitude as No. 32 + 205; slightly smiling lips. Feet, legs up to knees, r. forearm, part of club, l. hand with small lion missing; broken at hips; surface much worn; body badly damaged. Soft, white limestone. Height 51.0. Shoulder width 21.2. Waist width 13.0. Hips width 14.0. Deposit of sculptures. 78.8.
265. Base and feet of statuette; l. foot advanced; toes and nails sculptured. White limestone. Length 14.5. Deposit of sculptures. 78.0.
266. Fragment of l. leg of Herakles statuette with part of lion-skin attached. White limestone, slightly burnt. Length 12.5. Deposit of sculptures. 78.5.
267. Male statuette, as No. 132, but slightly widening upwards. Lower part of statuette, r. hand, and head missing. Grey limestone, burnt. Height 14.5. Breast to back 3.3. Shoulder width 6.8. Deposit of sculptures. 78.5.
268. Male statuette with plank-shaped body; both arms bent over breast; holding double flute with both hands; on r. shoulder the end of a broad plait is visible; wearing himation over l. shoulder, falling obliquely over the breast and wrapped around the body with overlapping borders; on l. side, below the bent elbow, an oblong object is attached which may be the flute case. Lower part of statuette, head, and l. shoulder missing. White limestone. Height 14.5. Deposit of sculptures. 78.0.
269. Fragment of torso of plank-shaped statuette. White limestone. Height 13.0. Deposit of sculptures. 78.0.
270. Oval head with prominent chin and cheeks; smiling, thin lips; nose in line with forehead; eyes of myrtle-leaf shape; large, plain ears; wreath around head; thick hair over forehead rendered by slightly curved grooves; veil rendered by zigzag notchings over head and falling over the long hair at back of head. White limestone. Total height 10.4. Head height 8.6. Length 7.0. Width 5.8. Deposit of sculptures. 78.0.
271. Base, feet, and part of lower body of plank-shaped statuette; feet isolinear, peeping out of plain chiton and resting on small base tablet; shoes painted red. White limestone. Length 13.0. Deposit of sculptures. 78.7.
272. Fragment of plank-shaped torso. Surface worn. White limestone. Height 30.0. Deposit of sculptures. 78.0.
273. Fragment of plank-shaped statuette; only r. part of lower body preserved. White limestone. Height 15.0. Deposit of sculptures. 77.7.
274. Head with oval face; rounded chin and cheeks; faintly smiling mouth; slightly parted, thick lips; nose in line with forehead; almond-shaped eyes, roughly cut ears; wreath around head; hair on head unworked; two rows of curls over forehead rendered by notchings; short hair at back of head. Part of wreath on r. side missing. White limestone. Total height 11.0. Head height 7.9. Length 6.0. Width 4.7. Deposit of sculptures. 77.7.
275. Fragment of a female statuette with plank-shaped body; slightly prominent breasts; probably isolinear feet; l. arm along side of body; r. arm bent over the breasts, its hand holding an object (flower?); double necklace around neck with central pendant partly covered by the object in r. hand; wearing an unfolded chiton with long sleeves. Lower part of statuette, l. arm, neck, and head missing. White limestone; worn. Height 15.2. Shoulder width 10.2. Deposit of sculptures. 77.7.
276. Fragment of statuette, belonging to No. 136. Deposit of sculptures 77.7.
277. R. part of torso of plank-shaped statuette; r. arm attached to body, slightly advanced. White limestone. Height 21.0. Deposit of sculptures. 77.7.
278. Head, belonging to No. 541. Deposit of sculptures. 78.0.
279. Small fragments of statuette. White limestone. Deposit of sculptures. 78.0.
280. Button-shaped head of multi-coloured glass, flat on one side, convex on the other; no hole. Diam. 1.0. Deposit of sculptures. 77.7.
281. Piece of lead. Length 8.0. Deposit of sculptures. 77.7.
282. Head, belonging to No. 222. Deposit of sculptures. 77.9.
283. Fragment of plank-shaped torso; l. leg advanced; much damaged. White limestone. Height 27.0. Deposit of sculptures. 78.0.
284. Torso, belonging to No. 242. Deposit of sculptures. 78.0.
285. Small fragment of r. part of plank-shaped statuette; surface much worn. White limestone. Height 11.0. Deposit of sculptures. 78.0.

286. Male statuette, as No. 132. Traces of red colour at neck and on chiton. Lower part of statuette and head missing; l. hand and buck damaged. White limestone. Height 20.0. Breast to back 4.3. Shoulder width 10.0. Deposit of sculptures. 78.0.
287. Male statuette, as No. 132. Lower part of statuette, r. arm, and head missing; neck of buck damaged; surface worn. White limestone. Height 24.5. Breast to back 4.8. Shoulder width 14.0. Deposit of sculptures 78.0.
288. Fragment of bent arm. White limestone. Length 19.0. Deposit of sculptures. 78.5.
289. Fragment of plank-shaped torso; much damaged. White limestone. Height 10.5. Deposit of sculptures. 78.0.
290. Part of l. side of torso of plank-shaped statuette; l. arm slightly bent forwards, holding conventionalized buck by its legs; chiton with folds rendered by careless, vertical grooves. Head and lower part of buck, and hand of statuette missing. White limestone. Length 22.0. Deposit of sculptures. 78.0.
291. Fragment of r. part of plank-shaped torso; much worn and damaged. White limestone. Height 15.5. Deposit of sculptures. 78.0.
292. Bronze nail with a flat, disc-shaped head; damaged. Length 2.3. Deposit of sculptures. 77.8.
293. Base and feet of statuette; l. foot advanced; toes marked by incised grooves. White limestone. Length 11.0. Deposit of sculptures. 78.5.
294. Oval head with slightly smiling, protruding lips; strong chin; rounded cheeks; rather prominent nose in line with sloping forehead, eyes of myrtle-leaf shape; rather large ears; wreath with large, plain leaves around head; two rows of curled hair over forehead, the curls rendered by zigzag notchings; plain veil on head and covering the short hair at back of head. Chin and r. cheek damaged; chin, nose, and part of curled hair chipped. White limestone. Total height 9.4. Head height 8.9. Length 7.7. Width 5.0. Deposit of sculptures. 77.0.
295. Torso of a Herakles, wearing an unfolded chiton; the forepaws of the lion-skin are knotted on breast; red girdle around waist, fastened by a simple knot. Only the part from hips to neck preserved. White limestone. Height 16.5. Waist width 7.7. Deposit of sculptures. 76.0.
296. Fragment of plank-shaped statuette. White limestone. Height 9.0. Deposit of sculptures. 78.5.
297. Fragment of statuette, belonging to No. 221. Length 13.0. Deposit of sculptures. 78.3.
298. Fragment of plank-shaped torso; much worn. White limestone. Height 14.5. Deposit of sculptures. 78.0.
299. Fragment of a head with wreath around head; face and back of head missing. White limestone. Height 17.1. Width 11.5. Deposit of sculptures. 78.0.
300. Fragment of statuette, belonging to No. 221. Length 13.0. Deposit of sculptures. 78.0.
301. Body of plank-shaped statuette; l. foot slightly advanced; l. hand holding conventionalized buck by its forelegs, long chiton with sleeves ending at elbows, the folds rendered by vertical, grooved lines; himation over l. shoulder with folds rendered by oblique, curved grooves and vertical border along l. side; shoes painted red; traces of red on himation. Head missing. White limestone. Height 46.5. Shoulder width 13.5. Breast to back 5.2. Deposit of sculptures. 78.0.
302. Base and feet, l. foot advanced; shoes painted red. White limestone. Length 11.0. Deposit of sculptures. 79.3.
303. Hand, belonging to No. 33. Deposit of sculptures. 78.0.
304. Fragment of base with small remains of feet. White limestone. Length 15.0. Deposit of sculptures. 78.0.
305. Base with feet, belonging to No. 43. Deposit of sculptures. 78.5.
306. Fragment of wreath. White limestone. Length 6.8. Deposit of sculptures. 78.5.
307. Lower part of plank-shaped statuette. White limestone. Height 16.0. Deposit of sculptures. 77.7.
- 308—21. Male statuette with plank-shaped body; both arms slightly advanced; the l. hand holding bird; sloping shoulders; rounded head (No. 21); smiling mouth; prominent cheeks and chin; nose in line with forehead; eyes of myrtle-leaf shape; short hair covered by a veil; a row of curls over forehead, the curls rendered by oblique notchings; chiton with vertical, grooved folds and short sleeves ending at elbows; himation over l. shoulder with oblique folds of wide grooves and a broad, vertical, flat fold ending above knees. Lower part of statuette and hands missing; bird incomplete. White limestone. Height 32.0. Breast to back 5.3. Shoulder width 10.9. Head height 5.9. Width 4.2. Deposit of sculptures. 82.0.
309. Base and feet; l. foot advanced. White limestone. Length 11.0. Deposit of sculptures 77.0.
310. L. leg, belonging to No. 33. Deposit of sculptures. 78.0.
311. Base and feet of statuette; r. foot slightly advanced; shoes painted red. White limestone. Length 19.0. Deposit of sculptures. 77.7.
312. Base and feet; l. foot slightly advanced; shoes painted red. White limestone. Length 15.0. Deposit of sculptures. 77.9.
313. Fragments of statuette; much damaged. White limestone. Deposit of sculptures. 77.7.
314. Fragment of plank-shaped torso; border of himation marked by incised groove; plain surface on body. White limestone. Height 20.0. Deposit of sculptures. 77.7.
315. Fragment of a statuette with plank-shaped body, oval in section; vertical arms along the sides of body; closed hands; wearing chiton with short sleeves(?). Only upper part of body with r. hand preserved; much worn. Grey limestone. Height 31.5. Breast to back 5.7. Shoulder width 13.0. Width of body below hands 8.0. Deposit of sculptures 77.7.
316. Base with feet; l. foot advanced. White limestone. Length 20.0. Deposit of sculptures 78.0.

317. Fragment of r. arm, belonging to No. 141. Deposit of sculptures. 79.5.
- 318-337. Statuette with plank-shaped body; vertical arms along sides of body, closed hands; sloping shoulders; oval head with face much worn (No. 337); the hair falling in a compact mass at back of head; wearing long chiton and himation over l. shoulder with marked border lines. Feet missing; broken at neck and hips. White limestone. Height 20.2. Breast to back 31. Shoulder width 6.0. Deposit of sculptures. 77.7.
319. L. arm; much worn and damaged. White limestone. Length 27.0. Deposit of sculptures. 77.7.
320. Fragment of plank-shaped body; l. arm slightly advanced, attached to body; plain chiton with sleeves ending at elbows; r. part missing; body much chipped. White limestone. Height 17.0. Deposit of sculptures. 81.5.
321. Fragment of a statuette, belonging to No. 44. Deposit of sculptures. 77.0.
322. Fragment of r. hand with carelessly sculptured fingers; end of fingers missing. White limestone. Length 10.5. Deposit of sculptures. 77.0.
323. Fragment of base with small remains of feet; l. foot advanced. White limestone. Length 11.0. Deposit of sculptures. 77.0.
324. Base and feet; l. foot advanced. White limestone. Length 13.0. Deposit of sculptures. 77.0.
325. Fragment of hand, holding club. White limestone. Length 19.0. Deposit of sculptures. 76.3.
326. Shapeless fragment of large statuette; surface entirely damaged. White limestone. Length 21.0. Deposit of sculptures. 75.7.
327. Head, belonging to No. 44. Deposit of sculptures. 76.3.
328. Male statuette with plank-shaped body, narrowing towards the base; vertical arms along sides of body; closed hands; sloping shoulders; short neck; head rounded; broad cheeks and chin; slightly smiling mouth; nose in line with sloping forehead; large, plain ears; eyes of myrtle-leaf shape without lids; two rows of curled hair over forehead, the curls rendered by parallel notchings; wreath around head; hair falling in a compact mass at back of head; behind the ears the curls are marked by slightly curved grooves; long, plain chiton with traces of red visible. Part of r. shoulder and feet missing. White limestone. Height 35.2. Breast to back 3.8. Shoulder width 11.0. Head height 6.3. Length 5.3. Width 4.5. Deposit of sculptures. 76.5.
329. Fragments of statuette; much damaged. White limestone. Deposit of sculptures. 75.7.
330. Herakles' head, oval in shape; rounded chin; smiling mouth; eyes of myrtle-leaf shape; hair over forehead rendered by vertical, parallel notchings; lion-skin on head with oblique eyes; on back of head, part of the club. Worn; r. side of face damaged; nose missing. White limestone. Total height 9.0. Head height 6.5. Width 4.5. Deposit of sculptures. 76.0.
331. Fragment of r. arm, belonging to No. 141. Deposit of sculptures. 77.1.
332. Fragment of an arrow-head of bronze; only tang preserved. Length 4.5. Deposit of sculptures. In the filling.
333. Lower part of plank-shaped statuette; l. foot advanced; shoes painted red; plain chiton; himation with zigzag border in front and plain border along l. side. White limestone. Height 19.0. Deposit of sculptures. 79.0.
334. Base and feet; l. foot advanced; shoes painted red. White limestone. Length 14.0. Deposit of sculptures. 79.0.
335. Base with feet; l. foot advanced. White limestone. Length 5.4. Deposit of sculptures. 79.0.
336. Head, much worn; face missing. White limestone. Height 10.1. Length 6.0. Width 4.6. Deposit of sculptures. 77.7.
337. Head, belonging to No. 318. Height 4.5. Deposit of sculptures. 77.7.
338. R. hand with roughly sculptured fingers; only little finger entirely preserved. White limestone. Length 9.0. Deposit of sculptures. 77.7.
339. Fragment of plank-shaped torso; plain surface. White limestone. Height 15.0. Deposit of sculptures. 77.0.
340. Torso of a male statuette, flattened but rather full-bodied; roughly sculptured back; nude with the exception of a folded shawl which falls over l. shoulder, passes through r. armhole and is wrapped round r. arm; both arms along the sides of body, slightly bent; the l. one may have held a lion of which only worn remains are visible; folds of the shawl only roughly indicated at back. Lower parts of both legs, parts of both forearms and hands, and head missing; worn. White limestone. Height 34.8. Breast to back 6.0. Shoulder width 19.0. Deposit of sculptures. 76.7.
341. Base and feet; l. foot slightly advanced; only traces of r. foot preserved. White limestone. Length 20.0. Deposit of sculptures. 78.7.
342. Herakles' head, damaged and worn; part of the curled hair over forehead and lion-skin on head preserved. White limestone. Height 21.0. Width 8.9. Deposit of sculptures. 78.7.
343. Base and feet; l. foot advanced; traces of red paint on shoes. White limestone. Length 13.0. Deposit of sculptures. 79.3.
344. Fragment of a head with wreath around head; long hair at back of head leaving ears visible. Only part of wreath and part of r. side preserved; face missing. White limestone. Height 12.0. Length 9.5. Deposit of sculptures. 78.0.
345. Base and feet of statuette; l. foot advanced. Red paint on shoes. White limestone. Length 13.0. Deposit of sculptures. 77.7.
346. Fragment of a statuette, holding buck under l. arm and wearing chiton with sleeves to the elbows. Height 16.2. Breast to back 4.9. Shoulder width 11.5. Deposit of sculptures. 77.5.
- 347-510. Statuette of Herakles with l. leg slightly advanced

- and slightly bent; r. leg supports the pressure; medial axis of torso describes a curved line; r. arm raised; straight neck; oval head (No. 510) with slightly curved nose in line with forehead; almond-shaped eyes with lids; slightly smiling mouth; roughly cut ears; short, curled hair all over the head; dressed in a chiton with overfold, ending above knees; folds marked by shallow, vertical grooves. Traces of red on eyes and lips. Body worn; feet, l. leg up to knee, r. forearm, l. arm, and part of chin missing. White limestone. Height 52.1. Shoulder width 13.5. Breast to back 7.8. Waist width 10.0. Hips width 12.5. Head height 9.2. Length 8.7. Width 5.7. Deposit of sculptures 77.3.
348. Base and feet of statuette; l. foot slightly advanced. White limestone. Length 20.0. Deposit of sculptures 77.5.
349. Base and feet, belonging to No. 114. Deposit of sculptures 78.0.
350. Head, belonging to No. 254. Deposit of sculptures 79.5.
351. Head, belonging to No. 520. Deposit of sculptures 77.3.
352. Fragment of plank-shaped torso; lower part of vertical l. arm preserved, border of himation rendered by curved grooves across body. White limestone. Height 11.0. Deposit of sculptures 76.0.
353. Base, feet, and part of lower body; isolar feet peeping out of chiton; roughly marked toes; border of chiton painted red. White limestone. Height 11.0. Deposit of sculptures 76.0.
354. Breast of plank-shaped statuette. White limestone. Height 10.0. Deposit of sculptures 77.0.
355. Fragment of plank-shaped torso; surface entirely damaged. White limestone. Height 32.0. Deposit of sculptures 77.5.
356. Oval head with thin, well defined chin; strained cheeks; smiling mouth; eyes of myrtle-leaf shape; nose in line with forehead, the hair is parted in the middle and is marked by slightly curved grooves on head and falls along sides of neck in twisted plaits, leaving the ears visible. Tip of nose missing; worn. White limestone, slightly bluish. Total height 13.5. Head height 11.5. Length 8.5. Width 6.8. Deposit of sculptures 78.5.
357. Fragment of statuette, as No. 132. Feet and upper part of statuette missing. Red border on himation. Height 25.0. Width (upper part of fragment) 9.0. Deposit of sculptures 76.0.
358. Female statuette, with plank-shaped body, holding a tympanon with both hands, wearing a long chiton, necklace with small pendant around neck. Lower part and head missing, worn and damaged. White, rather greyish limestone. Height 21.3. Belly to back 3.6. Shoulder width 10.0. Deposit of sculptures 81.0.
359. Sitting statuette of so-called temple-boy type, the hair is visible in two plaits at either side of neck; wearing short, folded chiton rolled up to the hips, leaving parts of body naked, the folds marked by wide grooves, roughly sculptured at the back. Base: l. leg from knee, r. upper arm, l. arm, and head missing; much worn. White limestone. Height 24.7. Breast to back 7.2. Shoulder width 13.5. Deposit of sculptures 80.0.
360. Herakles' head with short chin; smiling mouth; prominent nose in line with forehead, eyes of myrtle-leaf shape; curled hair over forehead; lion-skin on head; small fragment of the club attached to back of head. Parts of neck and shoulders preserved. L. side of face worn. White limestone. Total height 7.5. Shoulder width 8.0. Head height 4.2. Width 2.4. Deposit of sculptures 77.0.
361. Fragment of plank-shaped torso; both arms vertical; surface worn. White limestone. Height 18.0. Deposit of sculptures 76.5.
362. Oval head with roundish face; strong chin; smiling mouth; nose in line with forehead; eyes of half-moon shape; wreath around head; curled hair over forehead, the curls rendered by rows of parallel notchings; hair at back rendered by vertical, curved rows of parallel notchings; slightly sculptured veil on head. Surface slightly worn. White limestone. Total height 8.7. Head height 6.9. Length 6.6. Width 4.5. Deposit of sculptures 76.5.
363. Base and feet, almost isolar. White limestone. Length 9.0. Deposit of sculptures 77.2.
364. Fragment of small head with smiling mouth; straight nose; plain, long hair. Both sides of head missing; surface much worn. White limestone. Height 8.0. Deposit of sculptures 78.7.
365. Fragment of base; l. foot preserved; sculptured toes. White limestone. Length 13.0. Deposit of sculptures 77.5.
366. Fragment of plank-shaped torso; arms attached to body, slightly advanced. White limestone. Height 9.5. Deposit of sculptures 77.3.
367. Fragment of a Herakles' torso with remains of lion-skin ending at knees. Much damaged and chipped. White limestone. Height 16.0. Deposit of sculptures 76.5.
368. Torso of Herakles with l. leg advanced; r. arm raised; the forepaws of lion-skin tied in a large knot on breast. Feet, r. leg up to knee, l. leg up to thigh, head, r. forearm, and l. arm missing; surface much worn. White limestone. Height 29.5. Waist width 9.9. Deposit of sculptures 76.5.
369. Fragment of plank-shaped torso; plain surface; worn. White limestone. Height 12.0. Deposit of sculptures 76.5.
370. Fragment of a statuette, belonging to No. 62. Deposit of sculptures 78.0.
- 371-457
Upper part of female statuette with prominent breasts; r. arm bent over the breast; wide neck; oval head (No. 457) with prominent chin; smiling, protruding lips; nose in line with sloping forehead; eyes of myrtle-leaf shape; plain ears with large earrings in shape of a flower; hair parted in the middle; the curls over forehead rendered by rows of parallel notchings, bonnet-shaped hairdress consisting of rows of bands in zigzag pattern separated

- by horizontal bands across the hair; wearing thin, folded chiton; below r. arm a vertical row of tight, parallel, horizontal folds are visible; himation over r. shoulder falling in oblique, flat folds over body. Lower part of statuette, r. hand, l. arm, and part of l. side missing; surface worn. White limestone, slightly burnt. Height 36.5. Front to back 7.3. Shoulder width c. 15.0. Head height 9.0. Length 8.2. Width 4.8. Deposit of sculptures. 78.0.
372. Torso of plank-shaped statuette; surface entirely chipped. White limestone. Height 18.0. Deposit of sculptures. 77.3.
373. Torso of Herakles with slightly bulging breast; sloping shoulders; r. leg somewhat advanced; r. leg straight; r. arm has been raised; l. arm vertical, its hand grasping the mane of a small lion, which hangs along the thigh; dressed in short-sleeved chiton ending above knees; folds marked by vertical, parallel grooves; belt around waist tied in front. Head, r. arm, middle part of l. arm, l. leg from knee, part of lower r. leg, and both feet missing; upper body broken obliquely. White limestone. Height 37.1. Shoulder width 16.8. Waist width 7.7. Deposit of sculptures. 84.0.
374. Oval head with thin chin; slightly smiling mouth; leaf-shaped eyes; nose in line with forehead; wreath around head; hair on head rendered by grooves and ending over forehead with curls. Nose and l. side of face damaged. White limestone. Total height 8.8. Head height 8.0. Length 4.8. Width 4.7. Deposit of sculptures 84.5.
375. Terracotta statuette, moulded, dressed in richly draped himation; r. leg bent; l. leg supporting pressure; r. arm bent across breast and slung in a fold of the himation; l. arm bent, gathering folds of himation along l. leg. Head, r. leg, and feet missing; surface much worn. Height 9.5. Deposit of sculptures. 84.0.
376. Lower part of plank-shaped statuette; l. foot advanced; plain body. White limestone. Height 14.0. Deposit of sculptures. 76.0.
377. Fragment of base. White limestone. Length 18.0. Deposit of sculptures. 77.3.
378. Base and foot, belonging to No. 19. Deposit of sculptures. 77.5.
379. Base and feet, belonging to No. 255. Deposit of sculptures. 77.5.
380. Lower part of torso; r. foot slightly advanced; sandals with sculptured straps; chiton with vertical folds; himation with transverse, curved folds. White limestone. Height 69.0. Deposit of sculptures. 77.0.
381. Herakles' head, oval in shape; round chin and cheeks; softly smiling lips, painted red; straight nose in line with forehead; eyes of myrtle-leaf shape; hair over forehead rendered by vertical, parallel notchings; only small part of lion-skin, which is painted red, preserved on head. Nose chipped; back of head missing; l. side of face worn. White limestone. Total height 8.0. Head height 6.8. Width 4.2. Deposit of sculptures. 75.5.
382. Fragment of body, oval in section, with vertical arms close to the sides. Only middle part preserved; much worn. Grey limestone. Height 30.4. Deposit of sculptures. 75.5.
383. Fragment of head, with conical cap. White limestone. Height 9.0. Deposit of sculptures 79.5.
384. Base and feet of statuette; l. foot slightly advanced. White limestone. Length 8.0. Deposit of sculptures. 76.8.
385. Oval head with smiling, thin lips; eyes of myrtle-leaf shape; plain ears; wreath around head; three rows of curled hair over forehead, the curls rendered by parallel notchings; short hair at back of head with similar curls; plain veil on head. White limestone. Traces of red on lips and veil. Nose and r. eye missing. Total height 8.0. Head height 6.1. Length 6.0. Width 3.7. Deposit of sculptures. 76.3.
386. Lower part of plank-shaped statuette; l. leg slightly advanced; plain body; front part of feet missing. White limestone. Height 15.0. Deposit of sculptures. 77.5.
387. Narrow, oval head of a flute-player; a double flute held in place by a mouth-band; eyes of myrtle-leaf shape; nose in line with forehead; hair parted in the middle and marked by parallel grooves, leaving ears visible; tip of nose and flute missing. Much worn. White, slightly bluish limestone. Total height 8.9. Head height 7.7. Length 4.3. Width 4.3. Deposit of sculptures. 75.8.
388. Fragment of plank-shaped torso; plain body, but for a vertical groove along l. side. White limestone. Height 15.0. Deposit of sculptures 77.5.
389. Long, oval head with strong, prominent chin; slightly smiling mouth; thin nose in line with forehead; plain ears; short, convex cap on head; no hair visible. Surface much worn. White limestone. Height 10.6. Length 5.0. Width 4.2. Deposit of sculptures. 79.5.
390. 489. Lower part of a statuette, standing on a trapezoid base with straight legs; r. foot advanced; sandals with straps, rosette-ornament, and rather thick soles on feet; wearing long chiton with deep folds and himation with fan-shaped folds starting from l. side of body. Upper part of fragment worn. Both arms missing. White limestone. Height 79.0. Width at knees c. 23.0. Deposit of sculptures. 75.0.
391. Female statuette with plank-shaped body; concave sides; l. arm vertical along the side; r. arm bent over the breast, its hand holding pendant belonging to a simple necklace; prominent breasts; wearing unfolded chiton with long sleeves. Traces of red on chiton. Lower part of statuette and head missing. White limestone. Worn. Height 15.0. Shoulder width 7.6. Breast to back 3.2. Deposit of sculptures 77.0.
392. Oval head with prominent chin; nose in line with forehead; the eyes probably of myrtle-leaf shape; conical cap with elongated top, plain ears; no hair visible. Surface much worn. White limestone. Total height 11.4. Head height 5.9. Width 4.7. Deposit of sculptures. 78.0.

393-404-452.

- Male statuette with plank-shaped body (Nos. 393, 404), standing on a small, trapezoid base; l. foot slightly advanced; r. arm vertical along side of body, with closed hand, slightly advanced; l. arm bent, holding conventionalized buck with hind legs hanging down along side of statuette; roughly cut buck's head looking forward; head of statuette leaning forward (No. 452), oval in shape; slightly smiling mouth; nose in a line with forehead; eyes of myrtle-leaf shape; around head a conventionalized wreath leaving a row of curls visible over forehead; plain, long chiton ending at feet. Part of r. shoulder and back of head missing; broken above waist and at neck. Face worn. White limestone. Height 42.5. Breast to back 4.3. Shoulder width 9.8. Head height 5.5. Width 3.8. Deposit of sculptures. 77.8.
394. Fragment of head; only back of head with short, curled hair and part of wreath preserved. White limestone. Height 15.7. Width 12.2. Deposit of sculptures. 79.0.
395. Oval, narrow, long head; prominent, pointed chin; flat cheeks; nose line forms an obtuse angle with almost straight forehead; prominent eyes; hair falls in wig-shaped mass at back of head; soft, conical cap with upturned cheek-pieces. Surface much worn. White limestone. Total height 10.3. Head height 7.0. Length 4.0. Width 3.8. Deposit of sculptures 77.8.
396. Oval head with thin, sharply defined chin; full cheeks; smiling mouth; short, broad neck; oblique eyes of myrtle-leaf shape; nose and forehead forming a slightly convex line; large, roughly cut ears, hair over forehead forming an angular outline, the hair rendered by vertical, parallel grooves; long hair falling down at back of head, covered by a veil which is rendered by latticed incisions. White limestone, slightly burnt. Height 6.4. Length 6.0. Width 4.1. Deposit of sculptures. 77.5.
397. Oval head with short chin; fat cheeks, small eyes which might have been of myrtle-leaf shape; plain ears; short, convex cap with elongated top. Nose missing; surface much worn. White limestone. Total height 12.0. Head height 5.4. Length 5.6. Width 5.3. Deposit of sculptures. 78.0.
398. Hind part of lion statuette, upper part of hind legs and tail preserved. White limestone. Length 12.0. Deposit of sculptures. 78.5.
399. Oval head with prominent chin, small, straight mouth; nose in line with forehead; long eyes of myrtle-leaf shape; wreath around head; hair on head roughly indicated by some grooves; curled hair over forehead leaving ears visible. White limestone, slightly greyish. Total height 11.0. Head height 9.0. Length 6.5. Width 6.4. Deposit of sculptures. 77.5.
400. Torso of Herakles, with l. leg slightly advanced; r. arm was raised (now missing); l. arm was slightly bent, its hand holding small lion (arm and most of lion missing), short, folded chiton ending with a rather long, rounded flap in front, the folds rendered with vertical, almost parallel grooves; the forepaws of the lion-skin knotted on breast, the hind paws falling along the legs; girdle around waist. Feet, r. leg up to knee, both arms, neck, and head missing; broken at l. knee and waist. White limestone with yellowish patina. Height 53.0. Waist width 10.6. Hips width 13.7. Deposit of sculptures. 78.0.
401. Base with feet; damaged. White limestone. Length 35.0. Deposit of sculptures. 78.0.
402. Base and feet of statuette; feet almost isolinear but diverging; toes and nails sculptured; wearing strapped sandals. White limestone. Length 26.0. Deposit of sculptures 78.0.
403. Base, feet, and part of lower body of statuette with l. foot slightly advanced; plain body. White limestone. Height 7.0. Deposit of sculptures. 79.5.
404. Lower part of statuette with feet, belonging to No. 393. Deposit of sculptures 79.5.
405. Oval head with face nearly worn away; only part of l. eye which is of myrtle-leaf shape is visible; conical cap with elongated top on head; plain ears; the hair at back of head seems to be short; no hair over forehead is visible. Surface worn and damaged. White limestone. Total height 11.9. Head height 5.6. Length 5.4. Width 4.5. Deposit of sculptures. 80.3.
406. Small head, as No. 71. Much worn. White limestone. Tip of nose missing. Height 6.0. Width 3.2. Deposit of sculptures 79.5.
407. Fragment of a plank-shaped body with l. upper arm along side of body; l. hand closed; oblique fold at himation. Grey limestone. Height 11.7. Belly to back 3.0. Width 6.4. Deposit of sculptures. 80.5.
408. Oval head with nose in line with forehead; eyes of myrtle-leaf shape; wreath around head with a row of conventionalized fruits over the curled hair on forehead; curls rendered by small notchings; hair on crown of head rendered by grooves radiating from back of head, the grooves separated by two fine incisions. Chin and mouth missing. White limestone. Height 11.5. Length 5.4. Width 5.4. Deposit of sculptures. 81.3.
409. Male statuette, as No. 545, but without vertical fold of himation. Head and toes missing; breast worn. White limestone. Height 37.0. Belly to back 3.6. Shoulder width 11.3. Deposit of sculptures 80.5.
410. Fragment, belonging to No. 245. Deposit of sculptures. 80.5.
411. Head with oval face; pointed chin; eyes of myrtle-leaf shape; small mouth with protruding lips; thin nose in line with forehead; plain, prominent ears; short, convex cap on head with elongated top; no hair visible. Surface worn. White limestone. Total height 7.8. Head height 4.2. Length 3.7. Width 3.8. Deposit of sculptures. 76.3.
- 412-488.
- Male statuette with plank-shaped body; head (No. 488) with prominent chin and conical cap with cheek-pieces. Lower part of statuette and l. hand missing,

- broken at neck; much worn. Yellow limestone. Height 24.5. Breast to back 2.7. Shoulder width 11.5. Head height 7.0. Length 4.3. Width 4.0. Deposit of sculptures 79.0.
413. Plain White VII bowl, shallow, rounded with flat base. Diam. 8.0. Deposit of sculptures. 79.0.
414. Base, feet, and part of lower body of plank-shaped statuette; isolinear feet; toes rendered by careless grooves. White limestone. Height 12.0. Deposit of sculptures. 76.5.
415. Male statuette with plank-shaped body; vertical arms along the sides of body; closed hands; sloping shoulders; ovoid head with soft face; rounded chin and cheeks; flattened crown of head; a faint smile on lips; narrow eyes of myrtle-leaf shape; nose-line forming obtuse angle with broad forehead; plain ears; plain hair parted in the middle, falling in a compact mass at back of head and in two plain plaits on the shoulders; hair covered by veil; chiton with short sleeves ending a little below shoulders; plain himation with marked border-line over l. shoulder. Lower part of body and l. arm missing; body worn; nose and r. ear chipped. White limestone with yellow patina. Height 29.0. Breast to back 5.6. Shoulder width 15.4. Head height 9.0. Length 6.6. Width 6.2. Deposit of sculptures. 80.5.
416. Torso of plank-shaped statuette; vertical arms; plain body; worn. White limestone. Height 13.5. Deposit of sculptures. 79.3.
417. Male statuette with plank-shaped body, oval in section; standing on a small base; r. arm along side of body, slightly advanced, with closed hand; l. arm bent, holding conventionalized buck along side of body; sloping shoulders; oval head with rounded chin and cheeks; slightly smiling lips; almond-shaped eyes; nose in line with forehead; around head wreath of myrtle-leaves; row of curls over forehead; hair falling in two plaits at sides of neck behind the ears and marked by broad, shallow grooves; long chiton with vertical, grooved folds and sleeves ending at elbows; himation over l. shoulder with vertical folds over breast and wound around the body, below arms, with oblique, grooved folds; the border painted red. Broken below neck; r. hand and r. side of head much worn. Height 58.0. Breast to back 6.5. Shoulder width 15.4. Head height 10.7. Length 7.6. Width 5.5. Deposit of sculptures. 81.3.
- 418 + 438. Male statuette with plank-shaped body, standing on small, trapezoid base with isolinear but diverging feet; r. arm vertical along side of body; l. arm bent, holding conventionalized buck at side; very sloping shoulders; long chiton with oblique, grooved folds over breast and vertical, parallel folds at lower part; himation over l. shoulder, with oblique, grooved folds across body. Red border on himation. R. arm from elbow, head, parts of buck, and base missing; broken and worn. White limestone. Height 50.5. Breast to back 5.8. Shoulder width 15.3. Deposit of sculptures 81.8.
419. Oval head with nose in line with forehead; wreath around head; hair over forehead with curls rendered by notchings; hair on top of head rendered by rough grooves; long hair at back of head; plain ears. Part of r. side, chin, and r. eye missing; much worn. White, soft limestone. Height 9.5. Length 6.8. Deposit of sculptures. 75.5.
420. Torso, belonging to No. 171. Deposit of sculptures. 81.5.
421. Fragment of plank-shaped torso; much damaged. White limestone. Height 27.0. Deposit of sculptures. 80.5.
422. Fragment of hand, holding club; much damaged. White limestone. Length 9.0. Deposit of sculptures. 79.5.
423. Fragment of bent arm; damaged. White limestone. Length 30.5. Deposit of sculptures. 79.5.
424. Fragment of plank-shaped torso; much damaged. White limestone. Height 14.0. Deposit of sculptures. 76.5.
425. Fragment of head with details of face worn away; the eyes might have been of myrtle-leaf shape; plain ears; curled hair over forehead; wreath around head; veil on head. White limestone. Height 10.9. Length 7.5. Width 7.3. Deposit of sculptures. 78.5.
426. Small, conical cover of terracotta. Height 3.6. Deposit of sculptures. 76.5.
427. Oval head with prominent chin; smiling lips; eyes of myrtle-leaf shape; plain ears; short, conical cap with marked, upturned cheek-pieces and elongated top with traces of red colour; no hair visible. Nose and l. eye damaged; surface much worn. White limestone. Total height 10.7. Head height 5.5. Width 4.7. Deposit of sculptures. 79.5.
428. Fragment of plank-shaped torso; much damaged. White limestone. Height 18.0. Deposit of sculptures. 75.5.
429. Head, similar to No. 186, but with rounded, softly sculptured face and gently smiling lips. Part of l. cheek and tip of nose damaged. Surface much worn. White limestone. Height 5.2. Length 4.2. Width 3.3. Deposit of sculptures. In the filling.
430. Head, neck, and part of r. shoulder; rounded, oblique head with very thick, short neck; rounded, broad chin; oblique cheeks; eyes of myrtle-leaf shape placed asymmetrically; thick nose in line with forehead; very small, slightly smiling lips placed just below nose; thick, plain hair falling along sides of neck, leaving the roughly shaped ears visible. White limestone. Total height 11.0. Head height 6.3. Width 4.1. Deposit of sculptures. 77.5.
431. Torso of a statuette with plank-shaped body; chiton with vertical, wavy folds and sleeves ending at elbows; folded himation over both shoulders with open front; red border on himation. Lower part of statuette and head missing; l. side worn and damaged; broken at breast. White limestone. Height 20.0. Shoulder width 10.3. Deposit of sculptures. 77.0.
432. Oval head with rounded chin; rounded, slightly prominent cheeks; smiling mouth with thin lips; nose in line with forehead; eyes of myrtle-leaf shape; wreath around head; hair on crown of head unworked; thick hair over

- forehead, the curls rendered by notched rows; short hair at back of head, the curls rendered by latticed incisions; plain ears. Part of r. side of head below ear missing. White limestone. Total height 10.0. Head height 7.8. Length 6.6. Width 5.1. Deposit of sculptures 77.3.
433. Fragment of upper body of a plank-shaped statuette; chiton with short sleeves; himation over l. shoulder with carelessly marked border-lines. Traces of red colour on himation. White limestone. Height 15.6. Width 10.6. Deposit of sculptures. 77.5.
434. Lower part of plank-shaped statuette; l. foot slightly advanced; plain body; front part of feet missing. White limestone. Height 15.5. Deposit of sculptures. 75.5.
435. Oval head with narrow chin; small, smiling mouth; nose in line with forehead; large, oblique eyes; plain ears; conical cap on head; no hair visible. Top of cap missing; surface worn. White limestone. Height 7.5. Length 5.0. Width 4.5. Deposit of sculptures 76.0.
436. Plank-shaped torso; r. arm attached to body and slightly advanced; plain himation over l. shoulder, falling obliquely across breast; surface much damaged. Lower part of body, l. arm, upper part of r. arm, and head missing. White limestone. Height 22.0. Deposit of sculptures. 76.5.
437. Oval head; strong, prominent nose, forming concave line with forehead; eyes of half-moon shape; plain ears; conical cap on head; no hair visible. Top of cap missing; chin and mouth damaged; surface worn. White limestone. Height 8.5. Length 4.8. Width 5.0. Deposit of sculptures. 76.5.
438. Fragment of a statuette, belonging to No. 418. Deposit of sculptures. 76.5.
- 439-504.
Fragment of large statuette; r. leg advanced; l. leg bent; mantle with folds rendered by carefully sculptured, curved ridges across body; heavy zigzag folds along l. side. Feet, part of upper body, and head missing; upper part of fragment much damaged and worn. White limestone. Height 64.0. Deposit of sculptures. 80.5.
440. Fragment of base with r. foot partly preserved; shoe painted red. White limestone. Length 18.0. Deposit of sculptures. 78.5.
441. Fragment of head with oval face; rounded chin, smiling mouth, nose in line with forehead, eyes of myrtle-leaf shape. Only face preserved. White limestone. Height 8.8. Width 5.0. Deposit of sculptures 79.0.
442. Small, oval head with prominent chin; eyes without lids, plain, long hair covering the ears; r. side damaged, surface much worn. White limestone. Height 6.1. Width 3.3. Deposit of sculptures 79.2.
443. Fragment of a male statuette with plank-shaped body. Only part of body with l. hand and upper arm preserved. White limestone. Height 25.5. Front to back 3.3. Width below l. hand 9.0. Deposit of sculptures 79.5.
444. Breast of plank-shaped statuette; r. arm bent across breast, l. part of breast missing. White limestone. Height 8.0. Deposit of sculptures 77.5.
445. Male statuette, as No. 132. Lower part, r. arm, head, and parts of back missing. White limestone. Height 24.5. Breast to back 6.2. Shoulder width 13.9. Deposit of sculptures. 75.5.
446. Base and feet, belonging to No. 131. Length 14.5. Deposit of sculptures 77.0.
- 447+505
Lower part of Herakles statuette, standing on base block (base and feet = No. 447); free legs; l. leg slightly advanced; sculptured toes; strong calves, dressed in lion-skin reaching knees; carrying lion with l. hand; head of lion and statuette above hips missing. White limestone. Height (base included) 51.0. Legs to knees 23.0. Legs to hips 48.0. Deposit of sculptures. 75.0.
448. Oval head with rounded, narrow chin; smiling mouth; nose in line with forehead; plain ears; short, conical cap with upturned cheek-pieces and elongated top; no hair visible. Eyes worn out; surface much worn. White limestone. Total height 11.5. Head height 4.8. Width 4.7. Deposit of sculptures. 80.0.
449. R. hand, holding fragment of spear, belonging to No. 139. Deposit of sculptures. 81.0.
450. Head, belonging to No. 82. Deposit of sculptures. 80.5.
451. Fragment of head, oval in shape, with smiling mouth; nose in line with forehead; wreath around head; two rows of curled hair over forehead; r. side of head missing; surface much worn. White limestone. Total height 13.4. Head height 10.3. Length 9.5. Deposit of sculptures. 78.0.
452. Head, belonging to No. 393. Deposit of sculptures. 82.8.
453. Fragment of head with oval face; slightly smiling mouth with rather thick lips; wide, round chin; full cheeks, nose in line with forehead, eyes of myrtle-leaf shape; two rows of curled hair over forehead with parallel notchings; wreath around head. Only face and small part of wreath preserved. White limestone. Height 6.6. Width 3.7. Deposit of sculptures. 74.0.
454. Fragment of base and feet of large size. Much damaged and fragmentary. White limestone. Length 26.0. Deposit of sculptures. 72.5.
455. Torso of plank-shaped statuette, l. leg advanced; dressed in sleeved chiton; folds rendered by parallel, notched lines. Lower part of body, r. arm, lower part of l. arm, and head missing; surface much worn. White limestone. Height 75.0. Deposit of sculptures 75.0.
456. Oval head with rounded chin; full cheeks; smiling mouth with thin lips; plain ears; nose in line with forehead; eyes of myrtle-leaf shape; roughly sculptured wreath around head; hair over forehead rendered by parallel, notched rows; hair on top of head rendered by grooves, long hair falling in a compact mass at back of head. R. side of head worn; nose chipped. White limestone. Total height 10.1. Head height 8.3. Length 6.6. Width 5.2. Deposit of sculptures. 75.0.
457. Head, belonging to No. 371. Deposit of sculptures. 75.0.

458. Fragment of a head with wreath; plain ears. Face worn away. Height 13.8. Length 8.5. Deposit of sculptures. 73.5
459. Male statuette, as No. 412-488. Lower part from r. elbow missing; broken at neck; much worn. White limestone. Height 20.0. Breast to back 2.7. Shoulder width 3.2. Head height 8.0. Length 5.0. Width 5.3. Deposit of sculptures. 71.5.
460. Head, belonging to No. 64. Deposit of sculptures. 74.5.
461. Oval head with short, rounded chin; smiling mouth, eyes of myrtle-leaf shape; nose in line with forehead; plain ears placed obliquely; short, conical cap; side-curls of hair along back of neck. White limestone with yellow patina. Total height 10.5. Head height 5.0. Length 4.1. Width 4.2. Deposit of sculptures. 69.5.
462. Fragment of plank-shaped statuette. White limestone. Height 14.5. Deposit of sculptures. 71.5.
463. Head, almost rectangular in shape, with strong, prominent chin; fat, prominent cheeks; thin, smiling lips; thin nose in line with forehead; eyes of myrtle-leaf shape; slightly convex, long cap; hair visible below helmet as a wavy band over forehead and falling down back of head, leaving the plain ears visible. R. cheek damaged. Traces of red on helmet. White limestone. Height 9.0. Length 4.0. Width 2.8. Deposit of sculptures. 72.5.
464. Fragment of statuette, as No. 536-543, but without hair on forehead. Traces of red on cap. Lower part missing; worn. White limestone. Height 33.0. Shoulder width 9.9. Width of body below l. hand 7.7. Breast to back 3.6. Deposit of sculptures. 69.5.
465. Fragment of a male statuette, rather full-bodied and oval in section; r. arm raised; l. arm bent along side of body, holding buck close to the side; vertically folded chiton with sleeves ending at elbows; himation over l. shoulder with grooved, oblique folds across body and vertical, flat folds between legs. Lower part of statuette, r. forearm missing; head of buck missing. White limestone, slightly burnt grey. Height 35.0. Breast to back 7.4. Shoulder width 15.1. Deposit of sculptures. 68.5.
466. Lower part of plank-shaped statuette; l. foot slightly advanced; shoes painted red; plain body. White limestone. Height 14.0. Deposit of sculptures. 65.0.
467. Fragment of the lower part of nude, female statuette, with isolinear feet. R. side damaged. White limestone. Height 11.0. Deposit of sculptures. 65.0.
468. Oval head with prominent chin; slightly smiling lips; thin nose forming convex line with forehead; eyes of half-moon shape; short, convex cap on head; no hair visible; plain ears. Top of cap broken; surface worn. White limestone. Height 6.3. Length 3.4. Width 3.2. Deposit of sculptures. 65.0.
469. Small bronze coin, much corroded and indecipherable. Diam. 0.9. Weight 1.0. Top debris.
470. Terracotta lamp, similar to No. 471. Length 8.0. Top debris.
471. Terracotta lamp with flat base, covered with mottled red and black, lustrous slip; concave disc with small, pierced filling-hole; short, rounded nozzle. In centre of disc a lion in relief walking to the l., surrounded by encircling relief lines; volutes at base of nozzle. Length 8.0. Top debris.
472. Terracotta lamp with base-ring; concave disc, pierced by filling-hole in the middle; loop-handle; rounded, short nozzle. Leaf ornament in relief on disc, surrounded by kymation; volutes at base of nozzle. No glaze. Length 9.8. Top debris.
473. Terracotta lamp partly covered with red glaze; flat base; concave disc with central filling-hole, surrounded by relief lines; large, crescent-shaped handle, pierced by a hole below; two nozzles (ends missing); volutes at bases of nozzles. Length 18.5. Top debris.
474. Flat, circular button of steatite, pierced by a hole in the middle; decorated with two incised, encircling lines. Diam. 2.3. Top debris.
475. Fragment of Red Figured Attic pottery. Length 13.0. Deposit of sculptures. In the filling.
476. Sack-shaped bottle of multi-coloured glass with flat base; upper part missing. Height 5.5. Top debris.
477. Upper part of female terracotta statuette. Surface much worn. Length 5.0. G 4-6. Levelling debris below floor of Layer 7.
478. Fragment of a head, with short hair, too much destroyed to be described in detail. Height 18.0. Width 10.0. G 4-6. Levelling debris below floor of Layer 7.
479. Lower part of plank-shaped statuette; feet almost isolinear but diverging; chiton with folds rendered by careless, vertical grooves; himation with zigzag folds along l. side; oblique folds across body, rendered by incised grooves; chipped and worn. White limestone. Height 22.0. G 4-6. Levelling debris below floor of Layer 7.
480. Fragment of goblet with short, cylindrical stem; profiled bowl, surmounted by flat, circular object which is divided in six parts by incised, diametrical lines. White limestone. Height 10.0. G 4-6. Levelling debris below floor of Layer 7.
481. Plain White VII jug with flat base; semi-oval body; concave neck; handle probably from rim to shoulder; upper part of neck missing. Height 7.7. G 4-6. Levelling debris below floor of Layer 7.
482. Fragment of statuette. White limestone. Length 15.0. G 4-6. Levelling debris below floor of Layer 7.
483. Lower part of plank-shaped statuette; feet almost isolinear but diverging; folds of himation rendered by wide grooves across body; much worn. White limestone. Height 30.0. G 4-6. Levelling debris below floor of Layer 7.
484. Herakles' head; eyes of myrtle-leaf shape; plain, disc-shaped ears; hair over forehead rendered by parallel, vertical grooves; lion-skin on head; fragment of the club attached to back of head. Nose chipped; face much worn. Broken. White limestone. Height 6.6. Length 6.6. Width 4.4. G 4-6. Levelling debris below floor of Layer 7.

485. Strip mounting of thin bronze leaf, decorated with embossed ornaments of palmettes and volutes. Incomplete. Length c. 5.0. G 4-6. Levelling debris below floor of Layer 7.
486. Fragment of head; much damaged. White limestone. G 4-6. Levelling debris below floor of Layer 7.
487. Male statuette with plank-shaped body; sloping shoulders; oval head with strong chin and sharply marked outline; prominent cheeks; a vivid smile on the lips; wide eyes of myrtle-leaf shape; large ears; the hair parted in the middle and falling in three detached plaits on front of shoulders and breast; thin chiton with sleeves ending above elbows and a himation over l. shoulder with marked border-lines. Only upper part of statuette preserved; l. arm missing; face and front hair much damaged. White limestone. Height 26.0. Breast to back 6.6. Shoulder width 18.0. Head height 9.4. Length 7.0. Width 5.3. G 4-6. Levelling debris below floor of Layer 7.
488. Head, belonging to No. 412. Deposit of sculptures. 66.0.
489. Base with feet, belonging to No. 390. Deposit of sculptures. 65.0.
490. Lower part of plank-shaped statuette with l. foot advanced; surface plain and worn. White limestone. Height 14.5. Deposit of sculptures. 63.5.
491. Fragment of a Herakles' head with rounded face; faintly smiling mouth. and eyes of myrtle-leaf shape. Height 6.3. Width 4.4. Deposit of sculptures. 64.5.
492. Oval head with short neck; wide, sharply defined chin; prominent cheeks; slightly smiling mouth; broad nose in line with sloping forehead; large, plain, disc-shaped ears; eyes of myrtle-leaf shape; slightly convex, long cap; hair visible below cap in front and long hair falling at back of head and along side of neck, the curls rendered by careless notchings. Top of helmet missing; red on lips, helmet, and on a small part of shoulder. White limestone. Total height 14.3. Head height 6.7. Length 6.0. Width 4.9. Deposit of sculptures. 63.0.
493. Fragment of plank-shaped torso; l. arm vertical, attached to plain body. White limestone. Height 10.0. Deposit of sculptures. 63.5.
494. Torso of plank-shaped statuette; arms vertical, attached to body; closed, plain hands; plain, sleeved chiton; plain himation over l. shoulder, falling obliquely across body. Lower part of body, l. hand, and head missing. White limestone. Height 16.0. Deposit of sculptures. 63.3.
495. Fragment of a group statuette representing a seated man with remains of hind legs of an animal in front of him, the man sitting on an elevated object with notched surface, perhaps a stone; wearing short tunic; arms were advanced; between legs a bowl-shaped object; possibly a representation of a milking scene. Head, l. leg, parts of arms, and fore part of animal missing. White limestone. Height 8.5. Deposit of sculptures. 62.0.
496. Lower part of plank-shaped statuette; feet almost isolar but diverging; chiton with folds rendered by vertical, careless grooves. White limestone. Height 13.0. Deposit of sculptures. 62.0.
497. Oval head with almost straight mouth; leaf-shaped eyes; wreath around head; curled hair in three notched rows over forehead. Back of head and most part of wreath missing; surface much worn. White limestone. Height 9.9. Width 5.3. Deposit of sculptures. 62.0.
498. Fragment of a head with wreath in hair. Much worn. White limestone. Height 14.1. Deposit of sculptures. 62.5.
499. Oval head with prominent chin; small, slightly smiling mouth; eyes of myrtle-leaf shape; plain ears; two plaits of hair along sides of neck; short, convex cap with rounded top; no hair visible over forehead. Upper part of nose missing; surface worn. White limestone. Total height 9.2. Head height 4.5. Length 3.8. Width 4.3. Deposit of sculptures. 62.0.
500. Fragment of torso of plank-shaped statuette; l. leg slightly advanced; folds of chiton rendered by vertical grooves; plain himation; surface worn. White limestone. Height 25.0. Deposit of sculptures. 65.0.
501. Fragment of large statuette; much damaged. White limestone. Height 38.0. Deposit of sculptures. 64.5.
502. Fragment of plank-shaped statuette; feet almost isolar but diverging; shoes painted red; folds of chiton rendered by careless grooves; plain himation over l. shoulder, falling obliquely with curved border across body. Both sides chipped off and head missing. White limestone. Height 32.5. Deposit of sculptures. 65.5.
503. Fragment of plank-shaped statuette; much damaged. White limestone. Height 18.0. Deposit of sculptures. In the filling.
504. Fragment of statuette, belonging to No. 439. Deposit of sculptures. 67.0.
505. Fragment, belonging to No. 447. Deposit of sculptures. 66.0.
506. Upper part of statuette with plank-shaped body; vertical arms along sides of body; oval head with smiling lips; eyes of myrtle-leaf shape; hair probably covered by a veil; chiton over l. shoulder. Lower part of body with hands missing; much worn. White limestone. Height 17.5. Breast to back 3.9. Shoulder width 10.0. Head height 6.7. Length 4.5. Width 3.6. Deposit of sculptures. 65.0.
- 507-508. Torso of a male statuette with plank-shaped body, elliptical in section; r. arm vertical along the side of body, holding some hanging object (sack?) in the closed hand; l. arm vertical along the side; in its hand, a bird held by a wing; chiton with vertical, grooved folds and short sleeves ending at elbows; himation over l. shoulder covering l. arm to elbow, with oblique folds of wide grooves over body and horizontal ones over l. upper arm. Lower part of statuette and head missing; head of bird missing; broken through body; chipped at l. shoulder and below breast. White limestone. Height 22.3. Breast to back 4.1. Shoulder width 9.2. Deposit of sculptures. 64.5.

509. Male statuette with plank-shaped body; standing on a small base; isolinear feet; vertical arms with closed hands; l. hand holding some object; long chiton with short sleeves and bordered himation over l. shoulder with flat, oblique folds marked with zigzag cuttings; chiton painted yellow, with red sleeves and red borders below neck and above ankles; himation painted red; traces of red colour at upper arms. Head missing; broken through legs. White limestone. Height 25.0. Breast to back 3.6. Shoulder width 8.8. Deposit of sculptures. 63.0.
510. Head, belonging to No. 347. Deposit of sculptures. 62.5.
511. Plain White VII jug with flat base; oval body; short, concave neck; flaring rim; handle from rim to shoulder. Much broken and repaired. Height 11.1. Deposit of sculptures. 64.0.
512. Fragment of statuette. White limestone. Height 35.0. Deposit of sculptures. 65.0.
513. Lower part of plank-shaped statuette; feet almost missing; body much damaged; part of chiton with careless, vertical grooves visible. White limestone. Height 17.0. Deposit of sculptures. 65.5.
514. Oval head with narrow, rather prominent chin; strained cheeks; straight mouth; nose in line with forehead; eyes of myrtle-leaf shape; plain ears; wreath around head; thick hair over forehead, rendered by parallel grooves; hair on head covered by a veil, falling down at back of head over the long hair. White limestone. Total height 8.7. Head height 6.2. Length 5.6. Width 3.8. Deposit of sculptures. 64.5.
515. Fragment of lion statuette. White limestone. Length 8.0. Deposit of sculptures. 74.5.
516. Fragment of a libation table consisting of a limestone slab, slightly hollowed out. Length 27.0. Deposit of sculptures. 74.5.
517. Moulded architectural fragment of limestone. Length 27.0. Deposit of sculptures. 74.5.
518. Fragment of large hand with sculptured fingers; only thumb and part of index preserved. White limestone. Length 19.0. Deposit of sculptures. 74.5.
519. Lump of iron. Length 5.5. Deposit of sculptures. 76.5.
- 520-351. Male statuette with plank-shaped body, elliptical in section; r. arm along side of body, slightly advanced, its hand holding circular object; l. arm bent, holding badly damaged buck along side of body; sloping shoulders; oval head (No. 351) with rounded chin and cheeks, slightly smiling lips; eyes of myrtle-leaf shape; nose in line with forehead; row of spiral curls over forehead; around head wreath of myrtle-leaves, short hair at back of head, the curls rendered by latticed grooves; chiton with parallel, vertical folds and sleeves ending at elbows; himation over l. shoulder with oblique folds over body and one vertical fold at l. side, on which faint traces of red are visible. Lower part from hands, nose, and front part of buck missing; broken below neck. White limestone. Height 38.5. Breast to back 10.2. Shoulder width 17.5. Head height 10.7. Length 8.0. Width 6.2. Deposit of sculptures. 74.5.
521. Roughly rectangular stone with oval cavity on upper side, probably used as a mortar or receptacle for offerings. White limestone. Length 20.0. Deposit of sculptures. 65.0.
522. Fragment of lower part of statuette; l. foot slightly advanced; shoes painted red; folds of chiton rendered by careless grooves. White limestone. Height 16.0. Deposit of sculptures. 63.5.
523. Square base of Ajia Paraskevi stone, with part of base and l. foot, belonging to statuette No. 10. Deposit of sculptures. 61.5.
524. Torso of plank-shaped statuette, female; l. arm vertical, attached to body; closed hand; r. arm bent below breast, holding flower; necklace with pendant; plain chiton with long sleeves. White limestone. Height 10.0. Deposit of sculptures. 69.0.
525. Fragment of Herakles leg, with part of lion-skin visible. White limestone. Length 15.0. Deposit of sculptures. 66.0.
526. Base, feet, and part of lower body of statuette; feet almost isolinear but diverging; shoes painted red; traces of red on plain chiton. White limestone. Height 14.0. Deposit of sculptures. 66.5.
527. Base and feet of statuette; l. foot slightly advanced; tongue of shoes with overfold; traces of red paint on shoes. White limestone. Length 12.0. Deposit of sculptures. 66.5.
528. Base, feet, and lower part of body of statuette; almost isolinear feet but diverging; shoes painted red; folds of chiton rendered by careless, vertical grooves. White limestone. Height 16.0. Deposit of sculptures. 63.5.
529. Fragment, belonging to No. 214. Deposit of sculptures. 73.5.
- 530-539. Male statuette with plank-shaped body, standing on a small base with l. foot advanced (No. 539); almost vertical arms along sides of body; closed hands; slightly rounded breast-line; sloping shoulders; oval head with conical cap; rounded chin; smiling lips; nose in line with forehead; eyes of myrtle-leaf shape; plain ears; hair falling in a compact mass at back of head down to shoulders; plain, long chiton. Broken at ankles, hips, and neck; nose chipped. White limestone. Height 56.0. Breast to back 5.5. Shoulder width 12.8. Head height 7.8. Length 6.2. Width 4.7. Deposit of sculptures. 72.5.
531. Statuette, as No. 532, but without sculptured dress. R. hand broken; head missing. White limestone with traces of soot. Height 44.5. Breast to back 5.9. Shoulder width 15.7. Deposit of sculptures. 72.5.
532. Male statuette with plank-shaped body, standing on a small base with l. foot advanced; shoes painted red; vertical arms along sides of body; long chiton with sleeves ending at elbows; himation over l. shoulder reaching just below knees. Red borders around neck and sleeves on chiton. Head missing, broken; slightly

- burnt on lower part. White limestone. Height 43.0. Breast to back 5.1. Shoulder width 14.8. Deposit of sculptures. 72.5.
533. Fragment of plank-shaped statuette. White limestone. Height 33.0. Deposit of sculptures. 73.0.
534. Oval head with slightly smiling mouth; strong chin and strained cheeks; nose in line with forehead; eyes of myrtle-leaf shape; short, convex cap on head; no hair visible; plain, disc-shaped ears. Surface much worn. White limestone. Height 10.1. Width 4.2. Deposit of sculptures 72.5.
535. Male statuette with plank-shaped body; l. arm vertical along side of body, with closed hand; r. arm bent over breast, its hand grasping the tail of a small lion; long chiton with marked border around neck; long himation over l. shoulder, falling obliquely over the breast and with a vertical fold at l. side. Lower part of statuette and head missing; lion's head damaged. Height 36.0. Breast to back 4.4. Shoulder width 17.6. Width below hands 11.5. Deposit of sculptures 72.5.
- 536-543. Male statuette with plank-shaped body, standing on a small base with isolinear feet; r. arm bent over breast, slung in a fold of the himation; l. arm vertical; closed hands; oval head with conical cap (No. 543); rounded chin; full cheeks, slightly smiling lips; eyes of myrtle-leaf shape without lids; nose in line with forehead; large, plain ears; the hair is visible in a row of curls below cap, the curls rendered by vertical, parallel grooves; at back of head hair falling in a mass down to shoulders; long, unfolded chiton with sleeves ending at elbows; himation falling over both shoulders with a triangular opening below neck. Red lips and feet; black iris; red cap; red chiton; black and red fringe of himation. White limestone. Height 44.5. Shoulder width 11.0. Width of body below l. hand 9.3. Breast to back 3.6. Head height 7.5. Length 5.7. Width 5.4. Deposit of sculptures. 75.3
- 537 Statuette, as No 531 Part of r. arm and head missing. White limestone with small traces of soot. Height 46.0. Breast to back 5.5. Shoulder width 14.5. Deposit of sculptures. 76.5.
- 538 Fragment of head; only part of r. eye preserved; long, plain hair falling at back of head and along sides of neck, leaving the disc-shaped ears visible. White limestone. Height 8.9. Width 4.2. Deposit of sculptures. 72.5.
- 539 Base with feet, belonging to No. 530. Deposit of sculptures 74.5.
- 540 Lower part of plank-shaped statuette; isolinear feet peeping out of chiton and resting on small base tablet; plain body; border of chiton with traces of red paint. White limestone. Height 17.5. Deposit of sculptures. 72.0.
- 541-278 Male statuette, rather full-bodied, standing on small base with l. leg and foot advanced, rather bulging breast; l. arm bent and advanced, with closed hand; oval head (No. 278) with prominent chin; prominent, rounded cheeks; nose in line with forehead; eyes of myrtle-leaf shape; hair falling straight down over forehead and rendered by vertical, slightly curved grooves; wreath around head; veil on head; short hair at back of head; long, plain chiton; himation with oblique, curved folds over body and vertical folds at left side from below l. arm, which is covered by the folds of himation; the body is visible through the dress. Part of base and r. forearm missing. White limestone, slightly burnt. Height 56.4. Breast to back 8.2. Shoulder width 15.5. Head height 10.0. Length 9.0. Width 6.0. Deposit of sculptures. 72.0.
542. Male statuette with plank-shaped body; vertical arms; oval head with rounded chin; full cheeks; smiling mouth; wide, straight nose; large eyes of myrtle-leaf shape; plain ears; conical cap; curled hair across forehead; unfolded chiton and himation over both shoulders. Traces of red on chiton, himation, and cap. R. arm and lower part of body missing; upper part of body worn. White, soft limestone. Height 28.0. Shoulder width 13.0. Head height 5.0. Length 5.4. Width 4.7. Deposit of sculptures. 72.0.
543. Head, belonging to No. 536. Deposit of sculptures. 72.0.
544. Oval head with short, rounded chin; smiling lips; rounded cheeks; nose in line with forehead; eyes of myrtle-leaf shape with lids; plain ears; short, convex cap on head; no hair visible over forehead but two strips of hair at either side of neck. Traces of red on lips. R. eye and nose worn; white, somewhat darkened limestone. Height 10.0. Length 4.7. Width 4.5. Deposit of sculptures. 73.5.
545. Male statuette with plank-shaped body, standing on a small base; naked, isolinear feet; vertical arms along sides of body, with closed hands; short, wide neck; oval, rather square head; rounded chin; full cheeks; thin, slightly smiling lips; nose in line with forehead, forming together an almost vertical line; eyes of myrtle-leaf shape without lids; rather high forehead; plain, roughly shaped ears; the hair is visible in a row of wavy curls over forehead and falling in a compact mass at back of head down to shoulders, the curls rendered at sides of neck by almost horizontal, parallel cuttings; fillet on head; long chiton with long sleeves; plain himation over l. shoulder. Red on lips, chiton, border of himation, and at ankles; black iris; traces of black on hair and red on fillet. White limestone with traces of soot on lower parts. Height 42.0. Breast to back 4.0. Shoulder width 10.0. Head height 6.5. Length 4.9. Width 4.3. Deposit of sculptures. 72.5.
546. Lower part of plank-shaped statuette; l. foot advanced; l. arm attached to body, slightly advanced; r. arm missing; worn surface. White limestone. Height 29.0. Deposit of sculptures. 71.5.
547. Fragment of a plank-shaped body. Height 22.5. Deposit of sculptures. 70.0.

548. Two painted stucco fragments decorated with borders, painted blue and red, and with stylized leaf ornaments in red colour. Top debris.
549. Statuette of Herakles with l. leg advanced; body and breast turned forwards; r. arm raised (now missing); girdled chiton ending above knees; short himation over both shoulders down to waist. Traces of red on chiton. Surface much worn; legs to knees, piece of l. thigh, both arms, r. shoulder, and head missing. White limestone. Height 28.7. Shoulder width 14.2. Hips width 10.0. G 4—6. Levelling debris below floor of Layer 7.
550. Fragment of head with face completely damaged. The ears are plain and small part of wreath around head visible on each side of head. Surface much worn. White limestone. Height 11.0. Width 5.6. G 4—6. Levelling debris below floor of Layer 7.
551. Male statuette with plank-shaped body, elliptical in section; r. arm vertical; l. arm bent, holding conventionalized buck; chiton with wavy, grooved folds and short sleeves ending at elbows; himation over l. shoulder with oblique, grooved folds over body and a vertical, flat fold ending in wide zigzag folds below l. hand. Lower part of statuette, r. hand, and head missing; broken at body; surface worn. White limestone. Height 32.0. Breast to back 5.1. Shoulder width 13.0. G 4—6. Levelling debris below floor of Layer 7.
552. Male statuette, as No. 132. Feet, l. arm, and head missing; surface worn and damaged; broken at knees and above feet. White limestone. Height 38.0. Breast to back 4.8. Shoulder width 11.9. G 4—6. Levelling debris below floor of Layer 7.
553. Arrow-head of bronze; leaf-shaped; four-sided; pointed end; tang missing. Length 4.7. G 4—6. Levelling debris below floor of Layer 7.
554. a) Two bronze coins; Ptolemaic; much corroded and indecipherable. Diam. 2.0; 2.5. Weight 6.8; 3.5.
b) Two bronze nails, one straight and one bent; flat, disc-shaped head. Length 6.0; 6.7.
c) Folded piece of bronze mounting. Length 4.5.
d) Angular, pin-shaped mounting of bronze. Length 5.0.
e) Piece of lead. Length 4.2. G 4—6. Levelling debris below floor of Layer 7.
555. Terracotta lamp covered with red glaze; flat base; short, rounded nozzle; concave disc; small filling-hole. On disc rosette ornament in relief, surrounded by encircling lines; volutes at base of nozzle; part of nozzle missing. Length 8.7. Top debris.
556. Piece of lead. Length 3.4. Top debris.
557. Bronze coin; representation entirely worn out. Diam. 3.4. Weight 3.0. Deposit of sculptures. In the filling.
558. Lump of bronze. Length 5.0. Deposit of sculptures. In the filling.
559. Terracotta lamp of grey clay, with flat base; biconical body; flat top with raised edge; central filling-hole; end of nozzle missing; band-handle (part missing).
Around shoulder, stamped leaf ornaments; palmette and volute ornaments at base of nozzle. Length 9.0. I—H 2. Layer 6.
560. Rectangular base of limestone with a rectangular cavity on the top for insertion of a base block of a statue of which only the feet are left; left foot advanced; toes and nails sculptured. The exterior of the base is smoothed to about level 63.5 and the base is built into Wall 7 A. From the size of the feet it can be inferred that the statue was about life-size (cf. p. 21). Length of base 75.0. Width 55.0.
561. Oval, narrow, long head; prominent, strong chin; slightly smiling, protruding lips; flat cheeks; long nose; the line between nose and forehead slightly convex; large eyes of myrtle-leaf shape; short, conical cap with elongated top; upturned cheek-pieces, marked by incised lines; no hair visible. Red lips and painted iris. Back of head, r. ear, and top of helmet missing. Bluish limestone. Total height 10.8. Head height 6.1. Width 4.5. J 7. 66.5.
562. Fragment of a Plain White V jug. J 7. 70.5.
563. Bichrome III jug with base-ring; oval body; short, concave, rather wide neck; out turned rim; handle from rim to shoulder; tubular spout on shoulder. Encircling lines and bands around shoulder; on shoulder, bands of vertical, parallel lines and framed triangles filled with chequers; swastikas in the fields between; encircling lines around rim and base of neck; short-rippled line around neck; framed zigzag line on handle. Broken and parts missing. Height 17.0. I 5. 58.5—59.5.
564. Ten small, cylindrical beads of blue faience, with central holes. Diam. 0.8. I 5. 60.5.
565. Bronze nail with disc-shaped head, and fragments of others. Length 6.4. G 4—6. Levelling debris below floor of Layer 7.
566. Two bronze coins, much corroded and indecipherable. On reverse of one coin, a central knob. Diam. 2.4. Weights 5.4; 4.3. Top debris.
567. Biconical spindle-whorl of steatite, with a hole pierced lengthwise; decorated with incised circles. Length 1.9. G 4—6. Levelling debris below floor of Layer 7.
568. Ivory *stilus* with a moulded head, decorated with latticed incisions and surmounted with a carved miniature bottle of Hellenistic type. Pointed end missing. Length 8.5. F.6. 95.5.
569. Oval head with prominent chin; oblique cheeks; slightly smiling mouth; nose in line with forehead; eyes of myrtle-leaf shape; plain ears; wreath around head; hair over forehead, the curls rendered by shallow notchings; hair on top of head roughly grooved; long hair falling at back of head and along sides of neck; the side curls rendered by oblique, curved, shallow grooves. L. side of head worn. White limestone. Total height 8.8. Head height 6.9. Length 5.8. Width 3.2. G 2. Levelling debris below floors of Rooms 11, 12, 15.
570. Oval head with smiling mouth; nose in line with forehead; eyes of myrtle-leaf shape; rows of curled hair over

- the forehead, the curls rendered by parallel notchings; wreath around head; plain veil covering hair on head. L. side of head worn; r. side missing. White, soft limestone. Total height 8.9. Head height 7.7. Length 5.8. F 2. Levelling debris below floors of Rooms 11, 12, 15
571. Male statuette, as No. 28, but rather thick and wide at hips, l. arm is longer than the r. one. Red on chiton and feet. Head missing. Height 16.7. Breast to back 2.8. Shoulder width 8.0. Hips width (below hands) 5.4. G 2. Levelling debris below floors of Rooms 11, 12, 15
572. Base and r. foot with sculptured toes and nails. White limestone. Height 17.0. G 2. Levelling debris below floors of Rooms 11, 12, 15
573. Head, belonging to No. 246. F 2. Levelling debris below floors of Rooms 11, 12, 15.
574. Head with round face, small, straight mouth; nose in line with forehead; eyes of myrtle-leaf shape; notched hair over forehead; plain ears; long hair at back of head; plain diadem on head. White limestone. Total height 6.9. Head height 5.1. Length 3.8. Width 3.3. F 2. Levelling debris below floors of Rooms 11, 12, 15
575. Oval head with full cheeks; eyes of myrtle-leaf shape; nose in line with forehead; wreath around head; hair on crown of head rendered by grooves; rows of notched curls over forehead. Both sides of head missing; chin and mouth damaged. White limestone. Height 8.8. Length 5.1. F 1. 85.0.
576. Head, belonging to No. 52. F 1. 85.0
577. Fragment of terracotta idol. Height 12.5. E 1. 87.0.
578. Bronze nail with flat, disc-shaped head. Length 12.0. F 1. 85.0—85.5.
579. Half of a bronze coin; corroded and indecipherable. Diam 3.3. F 1. 87.0.
580. Bronze chain consisting of flat, hooked links joined by straight links through which small pins are passed. Length 6.8. E 3. 90.0.
581. Rectangular plaque of lead, probably a miniature copy of a table of offerings, with relief representations of cakes, hind legs of animals, leaves, fruits, and flowers. Length 8.0. E 1. 85.5.
582. Fragment of head with oval face, faintly smiling mouth; fat cheeks and chin; nose in line with forehead; eyes of myrtle-leaf shape, two rows of curled hair over forehead, the curls rendered by notchings; wreath around head. Only face with part of wreath preserved. White limestone. Height 6.4. Width 3.5. B—C 2—3. Mixed debris outside Room 18
583. Fragment of head; only face preserved; oval rounded chin; mouth with faint smile; thin, slightly concave nose, eyes of myrtle-leaf shape, no lids; sloping forehead, hair over forehead in two superimposed, notched rows. White limestone. Height 6.5. B—C 2—3. Mixed debris outside Room 18.
584. Head with round face; strong chin, full cheeks; slightly smiling mouth; eyes of myrtle-leaf shape; four rows of curled hair over forehead, the curls rendered by notchings; hair on head rendered by rough grooves; band around head held together by a flower and leaf ornament at front. Traces of red on the lips. Back of head, part of r. cheek, and nose missing. White limestone. Height 11.1. Width 5.3. B—C 2—3. Mixed debris outside Room 18.
585. Oval head with rounded chin; full cheeks; slightly smiling lips; nose in line with forehead; eyes of myrtle-leaf shape; wreath around head with leaves arranged in one direction; hair over forehead, the curls rendered in two rows of parallel notchings; rough grooves on top of head; long hair falling down at back of head and along sides of neck in roughly twisted plaits, leaving the plain ears visible. White limestone. Total height 8.1. Head height 6.4. Length 4.6. Width 4.0. B—C: 2—3. Mixed debris outside Room 18.
586. Lamp of terracotta, covered by black glaze, almost effaced; base-ring; watch-shaped body; central filling-hole with ring-shaped rim; knob on side; long nozzle; end missing. Length 8.0. B—C:2—3. Mixed debris outside Room 18.
587. Female statuette with plank-shaped body; standing on a small, square base with isolinear feet; shoes painted red; l. arm along side of body; r. arm bent over breast and holding an object (bowl?) between the slightly prominent breasts; double necklace around neck; unfolded chiton with long sleeves and red borders. Head with part of r. shoulder missing. White limestone. Height 14.4. Front to back 2.7. Shoulder width 5.0. B—C:2—3. Mixed debris outside Room 18.
588. Bronze coin, similar to No. 598, but rather worn. Diam. 1.9. Weight 7.1. B—C:2—3. Mixed debris outside Room 18.
589. a) Bronze coin. *Obverse*: Head of Arsinoe III, looking r, wearing stephane and earring. *Reverse*: Two cornucopiae, tied with fillet. Inscription worn. Cf. No. 601 b. Diam. 1.0. Weight 1.6.
b) Bronze coin. *Obverse* Entirely corroded. *Reverse*: Eagle standing on thunderbolt, looking l; wings open; much worn. Ptolemaic. Diam. 2.5. Weight 7.8.
c) Bronze coin. *Obverse*: Entirely corroded. *Reverse*: Horse (?) walking l. Much worn. Possibly Euagoras II. Diam. 2.2. Weight 2.5.
d—e) Bronze coins; corroded and indecipherable; parts missing. Diam. 1.7; 1.9. B—C:2—3. Mixed debris outside Room 18.
590. Head, belonging to No. 24. White limestone. B—C:2—3. Mixed debris outside Room 18.
591. Fragment of naked, full-bodied Apollo statuette; lower part of torso and thighs preserved; fragment of lyre attached to l. thigh. White limestone. Height 9.5. B—C: 2—3. Mixed debris outside Room 18.
592. Fragment of upper part of female statuette; body semi-circular in section; r. arm bent over the breast, its hand holding small object between the slightly prominent breasts; l. arm vertical along side of body; necklace around neck; plain chiton with long sleeves and red

- border around neck. Lower part of body, l. hand, and head missing. White limestone. Height 8.6. Breast to back 3.1. Shoulder width 6.0. B—C 2—3. Mixed debris outside Room 18.
593. Fragment of head with short, convex cap. Face and details worn out. White limestone. Height 10.5. Width 4.1. B—C 2—3. Mixed debris outside Room 18
594. Oval head with eyes of myrtle-leaf shape; prominent nose in line with forehead; plain ears; wreath of berries around head; rows of curled hair over forehead. R. cheek and mouth damaged. White limestone. Height 8.2. Width 3.5. B—C 2—3. Mixed debris outside Room 18.
595. Oval head with rounded but well defined chin and cheeks; slightly smiling mouth; nose in line with forehead; eyes of myrtle-leaf shape; plain ears; hair rendered by zigzag notches and falling in compact mass at back of head; wreath around head. L. ear missing. White limestone. Total height 9.5. Head height 7.5. Length 6.2. Width 5.2. B—C 2—3. Mixed debris outside Room 18
596. Bronze coin. *Obverse*: Head of Zeus Ammon looking r. *Reverse*: Eagle standing on thunderbolt, looking l.; wings open. Inscription worn away. Diam. 4.0. Weight 42.7. F 2. 90.0.
597. Bronze coin. *Obverse*: Head of Tiberius looking r. Inscription obliterated. *Reverse*: Head of Augustus, looking r., wearing radiate crown; in front thunderbolt. DIVOS AVGVSTVS PATER PATR. Diam. 3.3. Weight 16.4. F 3. 92.0—93.0.
598. Bronze coin. *Obverse*: Head of Alexander the Great looking r., with horn of Ammon; clad in elephant's skin and aegis. *Reverse*: Eagle on thunderbolt looking l.; wings open; between eagle's legs Σ , $\text{H}\Gamma\text{O}\text{.A}\text{E}\text{M}\text{H}\text{O}\text{O}$ ΒΑΣΙΛΕΩΣ. Diam. 2.3. Weight 4.5. E 3. 90.0.
599. Two bronze nails with flat, disc-shaped heads; fragment of a third nail. Length 9.8; 6.1. E 3. 84.0—89.0.
600. Fragment of an oval jug of buff faience, covered by blue glaze and decorated with ornaments in white glaze; radiating, furrowed lines around the bottom; a kymation frieze around neck; around belly, a frieze of figure representations consisting of a warrior riding on a horse, galloping to the r., with spear in his r. arm and attacking a bearded foot-soldier with spear in both hands and walking to the l.; an animal, buck(?), walking to the l. and followed by a man with head looking to the r. and whip in his r. hand. This central frieze is encircled by a frieze of rosettes on the shoulder separated from the central frieze by a band with small pellets in relief, and band of guilloche pattern and running dog ornaments below. Only half of body preserved; broken into many pieces. Height 9.2. E 3. 84.0—89.0.
601. a) Bronze coin. *Obverse*: Bull standing looking r.; star. *Reverse*: Bunch of grapes and star. Diam. 1.3. Weight 2.0.
b) Bronze coin. *Obverse*: Head of Arsinoe III looking r. and wearing stephane. Much worn. *Reverse*: Double cornucopiae, tied with fillet. $\text{H}\Gamma\text{O}\text{.A}\text{E}\text{M}\text{H}\text{O}\text{O}$ ΒΑΣΙΛΕΩΣ. Diam. 1.0. Weight 1.3.
- c—d) Two bronze coins, much corroded, indecipherable. Diam. 2.2; 2.1. Weights 4.2; 3.0. E 4. 84.0—89.0.
602. Mottled Black and Red Lustrous II bowl with base-ring; incurved rim. Diam. 12.5. D 4. 84.0—89.0.
603. Black Lustrous II bowl, shape as No. 602. Half missing. Diam. 12.5. D 4. 84.0—89.0.
604. Plain White open, saucer-shaped terracotta lamp with flat base; pinched wick-holder; plain rim. Length 7.9. D 4. 84.0—89.0.
605. Terracotta lamp, covered by red glaze; base-ring; biconical, watch-shaped body; central filling-hole with rim surrounded by double rings; string-hole knob at one side; straight, long nozzle with flat top (end missing). Alternating tree- and leaf-ornaments on shoulder; spear-head in relief on top of nozzle, framed by incised lines. Length 11.5. F 4. 92.0.
606. Terracotta lamp, covered by black and red mottled glaze, almost effaced; with flat, raised base; biconical, high body, central filling-hole with edges sloping inwards, surrounded by incised lines; knob at one side; nozzle missing. Length 8.2. F 4. 92.0.
607. Black Mat bowl, partly covered by slip; base-ring; double-curved, angular outline; flaring rim. Slip much effaced. Diam. 12.4. F 4. 92.0.
608. Three bronze coins, corroded and indecipherable. Diam. 2.3; 1.6; 1.7. Weights 4.4; 1.3; 0.9. E 3. 89.0—92.0.
609. Depressed globular bead of ivory, pierced by central hole. Diam. 2.1. E 4. 89.0—92.0.
610. Bronze coin. *Obverse*: Macedonian shield; in the centre, Gorgon's head facing. *Reverse*: Macedonian helmet with double crest and cheek-pieces; caduceus l.; rather worn. Diam. 1.7. Weight 3.3. D 4. 89.0—92.0.
611. Button-shaped bead of multi-coloured glass with flat base and convex upper side. Slightly damaged. Diam. 1.6. D 4. 89.0—92.0.
612. Plain White Hellenistic jug with pear-shaped body; base-disc. Neck and handle missing. Height 16.0. D 5. 89.0—92.0.
613. Red Lustrous II (black mottled) shallow bowl with base-ring; curved outline; incurved rim. Impressed ornaments of palmette star in the middle, surrounded by notched line. Diam. 11.8. C 6. 85.0.
614. Black Lustrous II bowl shape, as No. 613; plain. Parts missing. Diam. 12.5. C 6. 85.0.
615. Black Lustrous II (red mottled) shallow bowl with base-ring; curved sides; flattened, swollen rim. Diam. 15.5. C 6. 85.0.
616. Black Lustrous I bowl, shape as No. 613. Notched line inside. Diam. 13.5. C 6. 85.0.
617. Red Lustrous II (black mottled) bowl, as No. 614. Diam. 13.2. C 6. 85.0.
618. Fragment of a Cypriote capital of limestone with parts of volutes preserved. Length 16.0. D 5. 86.5.
619. Black Mat (red mottled) bowl, as No. 614; part missing. Diam. 8.3. E 4. 90.0.
620. Red Mat bowl, as No. 614. Diam. 8.5. E 4. 90.0.

- 621 Fragment of ante capital of limestone with concave and convex mouldings; covered with red and blue stucco. Length 14.0. E 4. 92.0.
622. Iron knife, straight, with one cutting edge, curved towards the point; flat tang, inserted in flat ivory handle, and fixed by three bronze rivets. Length 23.2 D 3. 87.0
- 623 Fragment of oval head with rounded cheeks, almond-shaped eyes; marked eyebrows, hair covered by a plain veil below which some plain hair is visible over forehead; large, roughly cut ears. Only parts of r. side of face preserved. White limestone. Height 9.3. J 7 66.5

CLASSIFICATION OF FINDS

Pottery (Pl. XXXVII).

The following classes are represented: Bichrome III (No. 563), Plain White V (No. 562), Plain White VII (Nos. 413, 481, 511), Red Figured Attic (No. 475), Black and Red Lustrous I—II Hellenistic (Nos. 602, 603, 613—617) Black and Red Mat Hellenistic (Nos. 607, 619, 620), and Plain White Hellenistic (No. 612).

Bichrome III Ware is represented by a jug with base-ring; oval body; short, concave neck; out-turned rim; handle from rim to shoulder. It is decorated with encircling lines and bands around the body; and on the shoulder, bands of vertical, parallel lines and framed triangles with filled chequers and swastikas in the fields between. Plain White V is represented by fragments of a jug (No. 562); Plain White VII by a shallow, rounded bowl (No. 413) and jugs with semi-oval body, concave neck, handle from rim to shoulder, or with oval body; short, concave neck; flaring rim; handle from rim to shoulder (Nos. 481, 511); Red Figured Attic by a sherd (No. 475); Black and Red Lustrous I—II Hellenistic by shallow, rounded bowls with base-ring and incurved rim (Nos. 602, 603, 613—617); Black and Red Mat Hellenistic by bowls of the same type (Nos. 619, 620) and bowl with base-ring and double-curved, angular outline (No. 607); Plain White Hellenistic by a sack-shaped jug (No. 612).

Stone sculptures.

The sculptures are classified into six different styles.

It is necessary to define the meaning of the term style in this classification. If we look at the sculptures of, e. g., Styles II and III it may seem strange that No. 52+576, which has a typically plank-shaped body, and No. 254—350, with a rather full-bodied torso, have been attributed to the same style, i. e. Style II. The same holds good for, e. g., No. 545 and No. 139—256—449 of Style III: No. 545 has a purely plank-shaped body, while No. 139—256—449 is full-bodied. If, however, only the head of No. 52—576 had been discovered there would be no objection to assigning this to the same style as No. 254—350 because they are both characterized by the same influence from the Eastern-Greek art upon the Cypriote sculpture. The structure of the head and features of the face form, therefore, the criterion of the style, more than the shape of the body, and this is entirely in accordance with the ideas of the Cypriote art, which more or less, and intentionally, neglects the formation of the body and concentrates upon the expression of the face. Moreover, the plank-shaped torsos of some sculptures form an intermediate stage between the full-bodied and the plank-shaped types, and there is no possibility of dividing these sculptures into different

styles because there is a continuous line, a coherent series from one extreme to the other. The same phenomenon holds good for the heads, too. Some heads of Styles II and III are closely akin to the Greek prototypes, others display more typical Cypriote features and a mixture of Greek and Cypriote types, but there is a coherent stylistic series of the heads, too. The sculptures of one style thus form a group of sculptures characterized by common, essential stylistic features, but they share these features to a higher or lesser degree and may be different in matters not considered essential by the artist.

Furthermore, it should be noted that the sculptures of each style are of very unequal artistic quality, and form a continuous series of decreasing quality from the master-pieces to the roughly worked specimens of the same style. The leading sculptures within each style are few. They have inspired the artists of the great mass of sculptures, which therefore represent the same style of art as the leading works, though in a conventionalized or rougher form.

The sculptures of each style are, if possible, divided into two classes, representing less and more advanced stages within the style. Some sculptures, however, are so fragmentary or in such a bad state of preservation, that they cannot be assigned to any of these classes within the styles, and, finally, there are fragments of sculptures which are of such insignificant character that they cannot be assigned with certainty to any definite style.

Mutatis mutandis, the same principles are used for the classification of the sculptures from the other sites, too.

Style I (Pls. V, VI, XIII: 1—3).

Two groups of sculptures, A and B, can be distinguished within this style. Style I A is represented by Nos. 186, 395, 437, 468, 561, and Style I B by Nos. 166, 397, 415, 429. Fragments of sculptures, which can be assigned to Style I, but not with certainty to any of these groups, include the following specimens: Nos. 26, 149, 198, 227, 391.

The bodies of the sculptures are of the plank-shaped type; the sides are concave, and the chest flat. The arms are usually strictly vertical, with clenched hands (No. 415), or one arm is vertical and the other bent across the chest (Nos. 198, 227, 391). Only the flute-players (Nos. 26, 149), who hold a double flute in their hands, have both their arms bent across the chest. The dress consists of a chiton with short sleeves, sometimes covered by a mantle wrapped round the body over the left shoulder, or over both the shoulders.

The sculptures of Style I A have long, narrow faces, of a strong, strained structure, with powerful chin and firm cheeks; the front of the face is sharply defined from the sides. The nose and forehead form either a slightly concave or convex line; the eyes are large and prominent, semi-lunar or myrtle-shaped; the lips are protruding, with their corners drawn up, but there is no smile, rather a grimace. The crown of the head is flat, which can be seen when it is only covered by a veil (No. 186); the conical cap, which covers other heads, is sculptured in rather high relief above the forehead. The hair falls in a compact mass at the back of the head, with straight or concave sides.

In Style I B the modelling of the face is softer, with smooth transitions between its different parts; no details are much accentuated, and the front part is not so sharply defined. The mouth is straight and the lips are rather thin; the eyes are of myrtle-leaf shape, smaller, narrower, and not so prominent. The form of the head is more rounded, ovoid and widening upwards. The hair and head-covering are usually the same as in Style I A, but the hair of No. 415 is parted in the middle and a plait hangs down on the breast on either side of the neck: a type of hair represented in Style II, too (cf. below). On the other hand, the slender structure of the body, the smooth, broad planes of the surface, the delicate details, and the artistic refinement of the carefully worked specimens, e. g. No. 415, show influence from the Egyptianizing school of Cyprus (cf. Vol. IV).

St y l e I I (Pls. VII—XII, XIII: 4—6).

Two main groups, A and B, are represented in this style, too, but the line of demarcation between these groups is not always clear. As in all the other styles, the sculptures naturally form a coherent series and, though the extreme types within each group are clearly distinguished, there are also some intermediate specimens. Nos. 67, 206, 218+178, 254—350, 356, 387, 389, 392, 411, 412+488, 448, 487, 506, 534, 623 are more or less typical specimens of Style II A, and Nos. 52+576, 71, 118, 187, 318+337, 364, 371+457, 396, 405, 406, 430, 435, 442, 459, 461, 499, 530—539, 544 can be assigned to Style II B. Fragments of sculptures which cannot be attributed to any of these groups include Nos. 32+205, 37+16, 62—182+370, 66, 70, 99, 108, 109, 112, 211, 222—282, 261, 264, 268, 352, 358, 494, 524, 531, 532, 535, 537, 571, 587, 592, 593.

Style II is characterized by the Eastern-Greek influence upon the Cypriote art of sculpture.

In the modelling of the body there are two different types: one type is plank-shaped, the other more full-bodied and best represented by the figure No. 254+350, the *chef d'œuvre* of the sculptures of this style. The plank-shaped body is the old-Cypriote type, which is characteristic of the earliest Cypriote stone sculptures and, as shown above, represented in Style I. It is, however, less flat than in Style I, the breast is more or less bulging, usually with a marked ridge between the upper and lower parts of the chest, and the sides of the body are not so concave. There are also intermediate types between the purely plank-shaped and more full-bodied torsos, e. g. Nos. 62+182+370, 218+178, 371+457, 530+539, with the hinder parts also indicated, and the outline of the legs visible through the dress. The figures stand in a frontal position, usually with the left leg advanced; the position of the arms is similar to that of Style I, except that the arms, when vertical, are not strictly so but only slightly advanced. The male dress consists of a chiton with sleeves ending at the elbows and very often a mantle, wrapped round the body over the left shoulder. The female mantle is of the Ionian, oblique type.

The sculptures of Style II A have a long and rather narrow head with vigorously modelled chin and cheeks; the eyes are large and more or less prominent; the nose is strong and in

a line with the forehead; the lips are firm and protruding, but the smile is not so vivid; the hair falls in a compact mass at the back of the head; it is either plain or sculptured in continuous plaits rendered by grooved lines, sometimes it is parted in the middle and arranged in plaits hanging freely down the breast on either side of the neck; the head is uncovered, or covered by a veil or a conical cap as in Style I.

Nos. 356, 387, and 487 may be considered as extreme and pure representatives of Style II A. Other sculptures, e. g. Nos. 254+350 and 218—178, are of a more mixed style. The eyes of No. 254—350 are rather narrow and not very prominent, but the nose and the lips are protruding, the still vigorous features are softened, and the expression of the face is mild and serene: the smooth surface, the delicate details, and the artistic refinement show some connexion with Style I B but, on the whole, the stylistic features are Style II A. The gently curved mouth of No. 218—178 with its vivid smile reminds one of Style II B and the nose is not prominent, but the large eyes and the long and narrow head with its sharp outline, are typically Style II A. Nos. 206 and 534 are also transitional types between Styles II A and B.

In Style II B the head is rounded, ovoid or almost trapezoid, and usually widening upwards; the modelling is soft and delicate; the chin and cheeks are smoothly rounded and sometimes fleshy; the eyes are narrower, not so prominent, and not seldom placed obliquely; the nose is usually in line with the forehead, but shorter than in Style II A. The lips are gently curved and the smile is more vivid; the hair of the male figures is similar to those of Style II A, but it is never parted in the middle, and the front-hair is often rendered in a different way, with narrow incisions or notches. Occasionally the hair is cut short, with a wreath instead of a *taenia* around the head (No. 118). This hair-dress is typical of Style III. The only female head preserved (No. 371+457) has a bonnet-shaped hair-dress, wrapped up by hands.

Style III (Pls. XIV—XXVII).

Two groups of sculptures called A and B, can be distinguished within this style, too. Nos. 10+42+164+523, 22+111, 33+191+213+303—310, 64—68—460, 96, 104, 117, 139+256+449, 141+167+170+175+207+220+317+331, 144+237, 235, 257, 270, 294, 308+21, 427, 432, 456, 463, 536+543, 541+278, 545, 594, belong to Style III A and Nos. 19+145+378, 24+590, 57, 100, 125, 157, 188+154, 219, 224, 234—250, 236, 242+253+284, 251+14, 362, 441, 492, 542, 569, 574, 583, 584, 585, 595 to Style III B.

The following fragments of sculptures can be attributed to Style III in general but not to any one of its two groups: Nos. 40, 53+142+163+241, 54—94, 61, 91, 93, 114—247+249+349, 115, 143+140, 169+229, 171—420, 204—208, 245—410, 255—379, 263, 275, 295, 333, 340, 360, 390+489, 409, 433, 439+504, 455, 464, 509, 549, 591.

The sculptures of Style III A form a direct continuation of those of Style II, and in some cases it is a matter of taste whether the sculptures are attributed to Style II B, or the beginning of Style III A. The limit between the styles is not always clearly defined, and a few sculptures show features characteristic of both styles. In general, however, Style III

is well defined. The parallel series of plank-shaped and full-bodied torsos continue, and there is the same marked ridge between the upper and lower parts of the breast, though somewhat rounded off. The plank-shaped bodies are usually still flatter and thinner than in Style II and quite rectangular, with straight sides. The legs and arms of the sculptures are placed in the same traditional positions as before. The only female figure represented, No. 235, has fuller breasts than the corresponding figure No. 371-457 of Style II but at the same time, the lower part of its body is somewhat thinner than that of No. 371-457. The sculptures of the Greek-influenced series have the same positions of the legs as in Style II but the positions of the arms are different from, and less stiff than, in that style. Usually the arms are advanced and slightly bent forwards so that they are detached from the body. Occasionally other positions are represented. No. 139-256-449 has the left arm advanced and the right one bent and uplifted, having held a spear. No 144-237 has the left arm advanced holding a votive offering of a buck, while the right arm is bent upwards and at the same time forwards in a gesture of adoration; the arms of the Herakles figures are kept in their usual and canonic position, and the female figure No. 235 has the same position of the arms as the corresponding figure No. 371-457 of Style II. The inherited frontal position is thus preserved, but the Herakles figure No. 64-68-460 shows a slight bend of the head. The figures are sometimes dressed in a short, girdled chiton only (Nos. 33-191-213-303-310, 64-68-460), leaving the lower part of the legs free, but usually in long chiton and mantle. The chiton has sometimes an overfold (Nos. 33-191-213-303-310, 64-68-460, 139-256-449). The Herakles figure No. 22-111 is naked, which occurs only rarely in Cypriote sculptures, and shows the Greek influence. The dress of the plank-shaped sculptures is only plain, slightly raised surface. On the sculptures of the less plank-shaped type the dress is usually folded. The same holds good for the dress of the full-bodied sculptures and the dress folds of the most carefully worked specimens, e. g. No. 10-42-164-523, are still less conventionalized and the surface of the himation is worked with a pointed chisel by which the textile stuff is rendered. A characteristic feature of these sculptures is that the body is visible through the dress (e. g. Nos. 10-42-164-523, 139-256-449, 235, 541-278) and the difference in stuff between the thick, woollen mantle and the thin, linen chiton, is represented, too (No. 139-256-449).

The head is more softly modelled than in Style II giving the face a smoother, rounded shape without very sharply defined transitions between its parts. The head of the plank-shaped sculptures is shorter in profile than those of Style II and with vertical, flat back. The smile of some specimens is still rather vivid but somewhat restrained on the more advanced ones. The eyes are of myrtle-leaf shape, both with and without modelled lids as before. The nose is in line with the sloping forehead. Some of the plank-shaped statuettes still wear a conical cap or helmet and their hair falls in a plain, compact mass down the back of the head. The hair of the other sculptures is rendered in various ways: it is often short, and marked by parallel grooves ending on the forehead, sometimes plain, but often with cork-screw curls in superimposed rows which are not found in Style II; on the less worked specimens, the cork-screw curls are rendered by shallow notches. Long hair is used, too, and

rendered in the same fashion as the short hair with grooves or notches; cork-screw curls occur only occasionally. This long hair either falls in a compact mass down the neck and shoulders or it is tied up on the back of the head. A wreath or a taenia are often wound around the head, sometimes combined with a covering veil. The hair of the female figure No. 235 falls in a compact mass down the back of the neck and shoulders and is rendered with shallow incisions and notches, as the corresponding hair of the male figures; three plaits fall on each side of the neck down the front of the shoulders; there is a remarkable difference between the rendering of the similar plaits on No. 487 of Style II and those of this figure: on No. 487 they are straight and stiff, sculptured in rather high relief, while on No. 235 they are made in low relief and stuck on to the body, following its rounded outline in the same way as the thin chiton.

The characteristic features of Style III B distinguishing it from Style III A may be summed up as follows. Though the inherited types of the body structure are predominant, there is one sculpture which shows a remarkable change in this respect: the Herakles figure No. 19 + 145 + 378 stands with both legs in profile and the left leg slightly bent, while the torso is seen *en face* and the head in three quarter profile. On the other hand, the purely Cypriote series of plank-shaped or almost plank-shaped sculptures display a general tendency to have the legs isolar and not the left leg advanced which is the rule in the earlier styles; and at the same time the arms are less advanced; a sign of increased conventionalism and stereotyped form. As regards the structure of the body it is worthy of notice that the almost angular ridge dividing the upper and lower parts of the breast which is typical of Styles II and III A has disappeared and the outline of the breast forms an evenly curved line. The faces are less vigorously modelled and the features are softened; on the most advanced specimens the smile has almost disappeared. The rendering of the hair follows the general tendency to conventionalism, with shallow, and somewhat careless incisions and notches. In the series of plank-shaped statuettes, the heads are still often covered with a conical cap or helmet, which has lost its curved outline and is straight-sided; the hair does not fall in a plain mass but its surface is notched and the notched curls come out of the cap in front.

Style IV (Pls. XXVIII—XXXIV).

In the same way as the sculptures of the preceding styles, those of Style IV are divided into two groups, called A and B. Nos. 44—321—327, 75—231, 82—450, 238, 239, 246—573, 328, 347 + 510, 374, 381, 385, 393—404—452, 399, 408, 417, 419, 453, 514, 520—351 belong to Style IV A and Nos. 133, 138, 194, 274, 451, 484, 491, 497, 570, 575 to Style IV B. The following fragments of sculptures can be attributed to Style IV in general but not to any of its two groups: Nos. 27, 34, 43—49—305, 56—58—95—193, 131—446, 132, 136—276, 148, 159, 162—217, 173—156, 189, 214—529, 216, 262, 267, 286, 287, 301, 357, 373, 380, 400, 418—438, 431, 445, 465, 479, 483, 500, 507—508, 551, 552.

In the Herakles figure No. 347 + 510 the strict law of frontality is broken by an attempt to represent a dynamic standing position: the right leg supports the weight, the left leg is

bent, and the medial axis of the torso describes a curved line, but there is no displacement of the hips. It cannot be doubted that this sculpture shows an attempt to appropriate the contemporary Greek "*Standmotif*". This renewed Greek influence is also shown by some of the large and more carefully worked heads, e. g. No. 239, and some body fragments of large statues, but the attempts to keep pace with the development of the early Classical sculpture of Greece are only sporadic and in general the Cypriote character of style becomes more and more predominant. The bodies are usually plank-shaped or show a tendency to become so. Only a few specimens preserve the more full-bodied type. The left leg is usually slightly advanced in Style IV A, but in Style IV B the isolinear position is common, or if the feet are not strictly isolinear, no longer the left leg, but, as a rule, only the left foot is slightly advanced.

Sometimes the heads are still rather long in Style III A but show a tendency to become shorter, and in Style IV B the short head is typical. In Style III A the features of the face have lost the Archaic strength, the form of the better worked specimens is still strained though stereotyped, the smile is stiff and sometimes almost disappears. In Style IV B the features are relaxed, the whole face is rounded off to an unelastic mass, the smile is very faint or has entirely disappeared. The period of decadence begins.

It is also interesting to notice the conventionalized representation of the animals brought by the figures as votive offerings compared with the more carefully worked specimens in the earlier styles, and to see how the forepaws of the lion-skin tied on the breast of the Herakles figures which, as a rule, are widely apart in the preceding styles, hang slack and nearer each other on the Herakles figures of this style.

In Style IV, as in the preceding styles, there is still an artistic affinity between the better worked sculptures and the rougher specimens which are inspired by the former and reflect the same style of art, though in a conventionalized form.

Style V (Pls. XXXV, XXXVI: 1—2).

This style is represented by the following specimens: Nos. 23, 30 + 20, 76, 134, 135, 202—35, 223, 258, 260, 290, 330, 359, 447—505, 496, 502, 522, 528, 582.

The sculptures are thus rather few in number and the majority consist of fragments, so that it is not possible to divide them into typological groups as in the preceding styles. A comprehensive analysis of the style cannot therefore be based on the comparatively scanty material found in Kiton but is given below in the classification of the sculptures, found in Mersinaki (Style IV) and Arsos (Style VIII). The sculptures of this style are a direct continuation of the roughly shaped, conventionalized sculptures of Style IV and show how the art sculpture degenerates into handicraft work with standardized types, gradually passing into pure idol sculptures.

Style VI (Pl. XXXVI: 3—6).

Only one sculpture of this style was found: No. 130, a Herakles head of an early Hellenistic type.

F r a g m e n t s.

Many fragments of sculptures are in such a fragmentary or bad state of conservation that their style cannot be determined with certainty. They include the following specimens: Nos. 8, 11—13, 15, 17, 18, 25, 28, 29, 31, 36, 38, 39, 41—160, 45—48, 50, 51, 55, 59, 60, 63, 65, 69, 72, 73, 77—81, 83—90, 92, 97, 101—103, 105—107, 110, 113, 116, 119—123 + 128, 124, 126, 127, 129, 137, 146, 147, 150—153, 155, 158, 161, 165, 168, 172, 174, 176, 177, 179—181, 183—185, 190, 192, 195, 197, 199—201, 203, 210, 212, 215, 221—297 + 300, 225, 226, 228, 230, 232, 233, 240, 243, 244, 248, 252, 259, 265, 266, 269, 271—273, 277, 279, 283, 285, 288, 289, 291, 293, 296, 298, 299, 302, 304, 306, 307, 309, 311—316, 319, 320, 322—326, 329, 334—336, 338, 339, 341—346, 348, 353—355, 361, 363, 365—369, 372, 376, 377, 382—384, 386, 388, 394, 398, 401—403, 407, 414, 416, 421—425, 428, 434, 436, 440, 443, 444, 454, 458, 462, 466, 467, 478, 482, 486, 490, 493, 495, 498, 501, 503, 512, 513, 515, 518, 525—527, 533, 538, 540, 546, 547, 550, 560, 572.

Terracotta sculptures.

Only four specimens of terracotta sculpture were found (Nos. 9, 375, 477, 577). Nos. 9, 477, and 577 are fragments of idol plastic, and No. 375 is a representative of the so-called Tanagra figurines.

Iron (Pl. XXXVIII).

Only a few objects of iron were found: a straight knife with one cutting edge; curved towards the point; flat tang inserted in a flat ivory handle and fixed by bronze rivets (No. 622); a straight pin (No. 2) and a shapeless lump (No. 519).

Bronze (Pl. XXXVIII).

The bronze objects are not numerous either: a four-sided arrow-head (No. 553) and fragment of an arrow-head (No. 332); nails with flat, disc-shaped head (Nos. 292, 554 b, 565, 578, 599); chain of flat, hook-shaped links (No. 580); strip-shaped mounting decorated with embossed ornaments of palmettes and volutes (No. 485) and pin-shaped mounting (No. 554 d); folded sheet (No. 554 c); shapeless lump (No. 558).

Lead (Pl. XXXVIII).

A rectangular table of offerings (No. 581) and shapeless lumps (Nos. 281, 554 e, 556) are the only lead objects.

Terracotta (Pl. XXXVIII).

Besides a conical cover (No. 426) the terracotta objects consist of lamps. Six types are represented.

1. Open, saucer-shaped lamp with pinched wick-holder; plain or flat rim (Nos. 4, 5, 98, 604).
2. Lamp with watch-shaped, or slightly biconical body; covered top with central filling-hole encircled by single or double relief rings or edges sloping inwards; knob on one side,

sometimes pierced by a string-hole; short or longer nozzle with rounded upper side. The lamps are covered with black or red glaze (Nos 3, 586, 606).

3. Lamp, similar to Type 2, but with squat, biconical body; nozzle with flat, upper side; decorated with moulded tree and leaf ornaments on the shoulder and a spear-head ornament on the nozzle (No. 605).

4. Lamp, similar to Type 2; biconical body; flat top with raised edge and provided with band-handle; on the shoulder, moulded leaf ornaments; palmettes and volutes at base of nozzle (No. 559).

5. Lamp with flat base; concave disc pierced by small filling-hole; short, rounded nozzle; on disc, moulded ornaments, floral or figural (No. 470, 471, 555).

6. Lamp, as Type 4, but with loop-handle. Moulded leaf ornaments on disc; volutes at base of nozzle (No. 472).

7. Lamp, as the preceding types, but larger, with large, crescent-shaped handle and two nozzles; volutes at base of nozzle (No. 473).

Faience (Pl. XXXIX).

Some cylindrical beads with central hole (No. 564) and a fragment of a jug (No. 600) are the only specimens of faience. The jug fragment is made of buff faience covered with blue glaze and decorated with ornaments in white colour; a central frieze of figure representations, horse-men, foot-soldiers, animals, etc., encircled by bands of kymation, rosettes, guilloche pattern, and running dog ornaments in a late Archaic style.

Glass (Pl. XXXIX).

The few glass objects consist of some beads and a bottle. The beads are made of blue, white and red-veined glass (No. 6), dark-glazed glass with white incrustations (No. 196), and multi-coloured glass (Nos. 280, 611). No. 6 is globular in shape and without hole; No. 196 is globular too, but provided with central hole; it is decorated with circles of white incrustation; Nos. 280 and 611 are button-shaped with flat base, convex upper side, and without hole. The bottle No. 476 is sack-shaped, with flat base; the upper part is missing.

Stone (Pl. XXXIX).

The stone objects consist of a flat, circular button, pierced by a central hole (No. 474); a biconical spindle-whorl with central hole and decorated with incised circles (No. 567); a libation table (No. 516); a bowl possibly used as a receptacle for offerings (No. 521) and fragment of a similar object (No. 74); a goblet (No. 480); a rectangular stele (No. 209); fragments of a Cypriote capital and an ante capital (Nos. 618, 621), and other architectural fragments (No. 517).

Bone (Pl. XXXIX).

Only three objects of bone were found: a depressed, globular bead of ivory pierced by a central hole (No. 609) and two *stili* of ivory with carved, moulded heads (Nos 1, 568).



Fig. 23. Kition. The deposit of sculptures in the rectangular pit. The "innermost stratum", resting on slabs of Platform 34.

Stucco.

The stucco fragments No. 548 are decorated with stylized leaf ornaments painted in red and borders in blue and red.

Coins (Pl. XXXIX).

All the coins are of bronze: No. 589 c is possibly from the time of Euagoras II²; Nos. 588, 596, and 598 were struck by Ptolemaeus Philadelphus³; Nos. 589 a and 601 b by Ptolemaeus Philopator and Arsinoë III⁴; Nos. 554 a and 589 b can only be indentified as Ptolemaic, but an exact attribution is not possible on account of their corrosion and worn surface; No. 610 is Macedonian⁵ from the period 286—277 B. C.; No. 601 a is Euboean from the period 197—146 B. C.⁶, and No. 597 was struck by Tiberius⁷. The coins Nos. 7, 469, 557, 566, 579, 589 d—e, 601 c—d, 608, are entirely corroded and indecipherable.

CONDITIONS OF FINDS (FIGS. 23—29)

Very few objects were found in undisturbed culture strata. These objects are Nos. 1—7, 559, 568, 580, 596, 598, 605—612, 619, 620, discovered in strata of Period 9; Nos 575—579, 581 in strata of Period 8. Of these objects, the stone heads Nos. 575, 576 and the terracotta idol No. 577 cannot, however, be dated on this stratigraphical evidence as we know that the sculptures were removed from temenos to temenos, from Period 5 onwards to Period 8 (cf. below). The stone head No. 575 is of Style IV B and should therefore, on typo-



Fig. 24. Kition. The deposit of sculptures after removal of the "front stratum".

logical evidence, be assigned to Period 8, and the head No. 576 is of Style II B and should therefore be assigned to the middle or rather the end of Period 6 (cf. Chronology, p. 72). It is an important fact that the head No. 576 fits the plank-shaped torso No. 52 which was found in the large deposit pit (cf. below, p. 65), which proves that the sculptures buried in the pit were deposited in the temenos of Period 8. Nos. 561, 562, and 623 were found in strata of Period 6. For the stone heads Nos. 561 and 623 the same remarks as before regarding the sculptures and stratigraphy, hold good: these heads may very well be fragments of statuettes, removed to the temenos of Period 6 from that of Period 5 but, on the other hand, they cannot be later than Period 6. No. 560, the base of the cult statue of Period 5, is built into Wall 7 A of that period. Nos. 563 and 564 were found in a stratum of Period 4.

All the other objects were found in disturbed layers, mixed layers of debris, or buried in deposits together with finds of various periods. For the dating of these objects we have therefore altogether to rely on typological evidence. The conditions attending the finding of these objects may be summed up as follows: Nos. 8—468, 475, 488—547, 557—558 were found in the large pit dug in Squares J—K:4—7. It has been shown in the preceding that



Fig. 25. Kition. The deposit of sculptures before removal.

the pit was dug at the beginning of Period 9 when the last temple was demolished and served as a depository for the waste *ex votis* of the demolished temple. It can therefore be inferred that the objects found in this pit must be earlier than Period 9. Their further chronology and *terminus post quem* can only be based on typological evidence. A stylistic examination of the sculptures, which form the overwhelming majority of these finds, shows that the earliest sculptures belong to Period 5 (cf. Classification of finds, pp. 55 ff. and Chronology, p. 72). From this we can infer that the *ex votis* were removed from the temple of Period 5 to the ensuing temple of Period 6 and at the destruction of that temple its *ex votis*, both those deposited in that temple and those removed from the temple of Period 5, were removed to the newly built temple of Period 7, whence they were again removed to the temple of Period 8, together with *ex votis* of Period 7. These *ex votis* of Periods 5—7, together with those of Period 8, were finally deposited in the pit at the destruction of the temple of Period 8. The conclusive proofs that the sculptures buried in the pit were deposited in the temenos of Period 8 is given by the sculpture No. 52 + 576, as mentioned above.

Nos. 477—487, 549—554, 565, 567, 569—574 were found in the levelling debris of Layer



Fig. 26. Kition. Detail of the deposit of sculptures.



Fig. 27. Kition. Detail of the deposit of sculptures.

7 below Platform 35 and the floors of Rooms 11, 12, 15. This platform, as shown above, was laid as a border round the top of the refilled pit in the beginning of Period 9, and the floors were laid at the same time. The objects in question, the majority of which are fragments of sculptures of the same kind as those buried in the pit, evidently consist of some waste *ex votis*, which happened to get into the levelling debris below the stratum of Period 9 instead of being buried in the pit. The typology of the non-sculptural objects found in this debris, of which the bronze coins No. 554 a cannot be earlier than Period 9, and the spindle-whorl No. 567 cannot be later than Period 6 (cf. Chronology, p. 73) also shows that this debris consists of a mixture of earth from different periods.

Nos. 582—595 were found in an accumulation of disturbed earth outside Room 18. This earth evidently comes from some illicit digging, and the objects found there thus form a mixed lot.

Nos. 599—604, 613—618, 621, 622 were found in the mixed debris along Walls 20—23, below the floor-level of Period 9. The objects in question are of two categories: Nos. 599, 600, 618, 621, and 622 were found scattered in the debris of Periods 7—8, disturbed by the erection of the walls of Period 9, while Nos. 601—604, 613—617 were found in definite groups. As these objects typologically belong to Period 9, it seems obvious that they were deposited below the floor of that period as foundation offerings at the erection of the house



Fig. 28. Kition. Group of sculptures leaning against the supposed boards in the lower pit.



Fig. 29. Kition. Group of Fig. 23 seen from the side.

complex of Period 9. The former objects thus belong to Periods 7—8, inasmuch as they are not removed from the temples of earlier periods; and the latter objects belong to the beginning of Period 9.

The bronze coin No. 597, struck by Tiberius, was found at level 90.0—91.0, in a stratum of Period 9. This period, however, must be assigned to Hellenistic times and cannot have continued until the Roman period (cf. Chronology, p. 72). This bronze coin must, therefore, be intrusive, though it could not be ascertained that the earth had been disturbed on the spot where it was found.

Nos. 469—474, 476, 548, 555, 556, and 566 were found in the top-debris which, as shown before, cannot be attributed to any definite period of habitation.

CHRONOLOGY

The chronology of the strata representing the ten successive periods stated above is based upon the intact vases of pottery and potsherds found in these strata. The intact vases are comparatively few and were not found in every stratum, the majority in strata representing Period 9 (cf. below). The chronology cannot therefore be based on the pottery vases alone, but this scanty and unequally distributed material must be completed with the great number of potsherds collected from the different strata. Nevertheless, great number of potsherds were found in disturbed layers and they are, of course, useless from a chronological point of view. Only potsherds from undisturbed layers are, therefore, registered in the Statistical list of potsherds given below.

	Square K 2.		<i>Level 48.5—40.5</i>	White Painted I 5
<i>Level 76.5—68.5</i>	White Painted V 4		Period 2 A	White Painted I—II 8
Period 6	Black Figured 1			White Painted II 4
	Plain White (Type V represented) 52			Black Slip I 1
				Black Slip I—II 1
<i>Level 68.5—66.5</i>	White Painted V 3	<i>Level 46.4—42.5</i>		White Painted I 10
Period 6	Plain White (Type V represented) 24	Period 1 B		Black Slip I 2
			<i>Level 42.5—40.5</i>	White Painted I 14
<i>Level 66.0—63.5</i>	White Painted IV 2	Period 1 A—B		
Period 5	White Painted V 6		<i>Level 40.5—10ck</i>	White Slip 1
	Black Slip V 1		Period 1 A	Levanto-Helladic 2
	Plain White (Types IV and V represented) 13			Sub-Mycenaean 9
				White Painted I 4
<i>Level 62.5—59.0</i>	White Painted V 2			
Period 4	Bichrome IV 1			Square J 2.
	Bichrome V 1		<i>Level 76.5—70.5</i>	White Painted V 6
	Black-on-Red II (IV) 16	Period 6		Bichrome V 1
	Black-on-Red III (V) 1			Black Glazed Greek 2
	Red Slip II (IV) 11			Black Figured 1
	Black Slip IV—V 1			Plain White (Type V represented) 7
	Plain White (Types IV—V represented) 20			
<i>Level 59.0—56.5</i>	White Painted III 6	<i>Level 70.5—66.5</i>		Plain White (Type V represented) 29
Period 3 B	White Painted IV 3	Period 6		
	White Painted III—IV 3		<i>Level 66.5—64.5</i>	White Painted IV 1
	Black-on-Red I (III) 1	Period 5		White Painted IV—V 2
	Black-on-Red II (IV) 16			Black-on-Red II (IV) 6
	Red Slip I (III) 2			Black-on-Red III (V) 4
	Red Slip II (IV) 5			Red Slip II (IV) 3
	Black Slip III 2			
	Plain White (One Type II and some Type IV represented) 28			Red Slip III (V) 4
				Plain White (Types IV and V represented) 16
<i>Level 56.5—54.5</i>	White Painted II 2			
Period 3 A—B	White Painted II—III 6	<i>Level 62.5—56.5</i>		White Painted III 2
	White Painted III 8	Period 3 B—4		White Painted III—IV 3
	Black-on-Red I (III) 3			Black-on-Red II (IV) 1
	Black-on-Red II (IV) 4			Black-on-Red III (V) 2
	Red Slip I (III) 4			Black Slip II 1
	Red Slip II (IV) 2			
<i>Level 54.5—51.5</i>	White Painted II 1	<i>Level 54.5—51.5</i>		White Painted II 2
Period 3 A	White Painted II—III 2	Period 3 A		White Painted II—III 4
	Black Slip II 4			Bichrome II 1
	Red Slip I (III) 5			Black Slip Painted II 1
<i>Level 51.5—48.5</i>	White Painted I 2	<i>Level 51.5—48.5</i>		White Painted I 2
Period 2 B	White Painted II 8	Period 2 B		White Painted I—II 6
	White Painted III 3			White Painted II 5
	Black Slip I 1			
	Black Slip II 5	<i>Level 48.5—45.5</i>		White Painted I 5
	Red Slip I (III) 3	Period 2 A		White Painted I—II 6
				White Painted II 4

<i>Level 45.5—43.5</i> (Period 1 B)	White Painted I 4 White Painted I—II 2	<i>Level 69.5—68.5</i> (Period 6)	White Painted V 5 Bichrome V 1 Black Figured 1
<i>Level 41.5—39.5</i> (Period 1 A)	Late Helladic III 1 Levanto-Helladic 4 Syrian Red Slip 1 Sub-Mycenaean 8 White Painted I 7	<i>Level 68.5—66.5</i> (Period 6)	White Painted III—IV 1 White Painted V 3 Black Slip V 1
<i>Level 77.5—74.5</i> (Period 6)	Square L 5. White Painted V 2 Black-on-Red II (IV)—III (V) 1 Bichrome Red II (V) 1 Red Slip III (V) 1 Black Glazed 5 Black Figured 1	<i>Level 62.5—60.5</i> (Period 4)	White Painted III 5 White Painted III—IV 4 Bichrome III 1 Bichrome IV 1 Black-on-Red I (III) 1 Black-on-Red II (IV) 10 Black-on-Red III (V) 2 Black Slip III 4 Red Slip II (IV) 5 Red Slip III (V) 1
<i>Level 66.5—63.5</i> (Period 5)	White Painted IV 4 White Painted V 2 Bichrome V 3 Black-on-Red I (III) 1 Black-on-Red II (IV) 1 Black-on-Red III (V) 2 Black Glazed Greek 2 Black Figured 1 Plain White (Type V represented) 12	<i>Level 87.0—85.0</i> (Period 8)	Room 1. Much Plain White (Type VII and a few Type VI)
<i>Level 63.5—61.5</i> (Period 4)	White Painted III—IV 2 Bichrome IV 1	<i>Level 83.0—80.0</i> (Period 7)	Black Glazed Greek 7 Much Plain White VI.
<i>Level 61.5—60.0</i> (Period 4)	White Painted III 2 White Painted IV 2 Black-on-Red II (IV) 2 Red Slip II (IV) 2 Red Slip III (V) 1	<i>Level 71—66.5</i> (Period 6)	White Painted IV 1 White Painted V 1 Plain White (Type V represented) 12
<i>Level 59.0—56.5</i> (Period 3 B)	White Painted III 9 White Painted III—IV 7 Black-on-Red II (IV) 1 Black Slip III 1 Red Slip I (III) 1 Red Slip II (IV) 6	<i>Level 62.0—58.5</i> (Period 4)	White Painted III 3 White Painted III—IV 6 Black-on-Red II (IV) 1 Red Slip II (IV) 1
<i>Level 56.5—53.5</i> (Period 3 A)	White Painted II 4 White Painted II—III 9 White Painted III 5 Bichrome III 1 Red Slip I (III) 1	<i>Level 75.5—66.5</i> (Period 6)	Square K 4. White Painted IV—V 3 Bichrome IV—V 1 White Painted V 3 Black-on-Red II (IV) 1 Black-on-Red III (V) 2 Black Glazed Greek 2 Black Figured 1
<i>Level 51.5—46.5</i> (Period 2)	White Painted I 6 White Painted I—II 6 White Painted II 4	<i>Level 62.5—60.0</i> (Period 4)	White Painted III 3 White Painted IV 12 White Painted V 1 Black-on-Red II (IV) 3 Black-on-Red III (V) 1 Red Slip II (IV) 4
<i>Level 76.5—69.5</i> (Period 6)	Square K 3. White Painted V 2 Black Glazed and Red Figured 7	<i>Level 75.5—65.5</i> (Period 6)	Square K 7. White Painted V 3 Bichrome V 1 Black Glazed Greek 3

<i>Level 65.5—64.5</i>	White Painted IV—V 2		Much Plain White Hellenistic among which fragments of Rhodian amphorae.
Period 5	White Painted V 10		
	Black-on-Red II (IV) 4		
	Black-on-Red III (V) 3		
	Black Slip IV 1	<i>Above floor of Period 9</i>	
	Red Slip II (IV) 2	Period 9	Black Lustrous and Black Mat Hellenistic 15
	Red Slip III (V) 3		Red Lustrous and Red Mat Hellenistic 1
			Much Plain White Hellenistic.
<i>Level 58.5—56.5</i>	White Painted and Bichrome III 4		
Period 3 B	White Painted III—IV 3		
	Bichrome IV 2	<i>Level 88.0—85.0</i>	Black Glazed Greek and Plain White VII 32
	Black Slip II 1	Period 8	
	Black Slip III 1		
		<i>Level 84.0—82.0</i>	Black Glazed Greek 5
<i>Level 56.5—55.5</i>	White Painted and Bichrome III 5	Period 7	Black Slip VI 1
Period 3 B	White Painted and Bichrome IV 3		Plain White VI—VII 27
	Black-on-Red I (III) 6	<i>Level 82.0—80.0</i>	White Painted VI 2
	Black-on-Red II (IV) 4	Period 7	Black Glazed Greek 3
	Black Slip III 1		Plain White (Type VI frequently represented: pithoi with large loop-handles; torpedo pithoi, etc.) 25
	Black Slip IV 1		
	Red Slip I (III) 3		
<i>Level 55.5—53.0</i>	White Painted II 1		
Period 3 A	White Painted II—III 5		Square G 1.
	White Painted III 7	<i>Level 84.0—80.0</i>	White Painted VI 3
	Black Slip II 7	Period 7	Red Figured 5th Cent. B.C. 2
	Red Slip I (III) 2		Black Glazed Greek 18
	Red Slip II (IV) 1		Much Plain White (Type VI represented) 22
<i>Level 50.5—48.5</i>	White Painted II 8		
Period 2 B	White Painted II—III 12		Square H 6.
	White Painted III 2		
	Black Slip II 2	<i>Debris below Platform 35</i>	White Painted V (intrusive) 1
	Black Slip III 1	Period 8	White Painted VI 1
			Red Figured 4th Cent. B.C. 3
			Red Figured Late 5th Cent. B.C. 1
<i>Above floor of Period 10</i>	Room 4.		Black Glazed Greek 29
Period 10	Black Lustrous and Black Mat Hellenistic 4		Plain White (Types VI and VII represented) 35
	Red Lustrous and Red Mat Hellenistic 4		Black Lustrous Hellenistic 2

This statistical list of potsherds shows that Period 1 is characterized by a majority of potsherds of Cypro-Geometric I: White Painted I, Black Slip I, and Plain White I, and some specimens of the latest phase of Late Cypriote III: White Slip, Syrian Red Slip, Levanto-Helladic, Late Helladic III, and Sub-Mycenaean wares. The sherds of the latter category were found in the lower part of the strata of the period, in the earth on the solid rock. In the upper part of the strata the pottery is entirely of Cypro-Geometric I, with a few stray sherds of White Painted I—II Ware. Period 1 may, therefore, be divided into two sub-periods: Period 1 A and B, the former covering the end of Late Cypriote III and the

beginning of Cypro-Geometric I, and the latter covering the middle and late part of Cypro-Geometric I.

In Period 2 the pottery consists of a majority of Type II: White Painted and Bichrome II and Black Slip I—II, a minority of Type I: White Painted I, and some sherds of Type III: White Painted III, Black Slip III, and Red Slip I (III). It can be seen that the few sherds of Type III are only found in the upper part of the strata. In consequence of this distribution of the pottery types we can divide Period 2 into two sub-periods, of which Period 2 A covers the first part of Cypro-Geometric II, while Period 2 B can be assigned to the later part of Cypro-Geometric II and continues to the beginning of Cypro-Geometric III.

In Period 3 the majority of potsherds consists of Type III: White Painted and Bichrome III, Black-on-Red I (III), Black Slip III, and Red Slip I (III). Besides, a number of potsherds of Type II were found: White Painted and Bichrome II and Black Slip II, and a considerable number of Type IV: White Painted IV and Bichrome IV, Black-on-Red II (IV), Black Slip IV, Red Slip II (V). The list shows that the potsherds of Type IV — with the exception of a single sherd — occur only in the upper part of the strata, but they are there rather numerous. This difference in the composition of the pottery types in the upper and lower parts of the strata also accounts for a division of Period 3 into two sub-periods: Period 3 A, which can be assigned to Cypro-Geometric III, and Period 3 B, which continues to about the middle of Cypro-Archaic I.

Period 4 is characterized by a majority of potsherds of Type IV: White Painted and Bichrome IV, Black-on-Red II (IV), Black Slip IV—V, Red Slip II (IV), a few sherds of Type III: White Painted and Bichrome III, Black-on-Red I (III), Black Slip III, and some sherds of Type V: White Painted and Bichrome V, Black-on-Red III (V), Red Slip III (V). This combination of pottery types shows that Period 4 dates from the middle of Cypro-Archaic I to the beginning of Cypro-Archaic II.

In Period 5 the potsherds are almost exclusively composed of Types IV and V: White Painted and Bichrome IV—V, Black-on-Red II (IV) —III(V), Black Slip IV—V, and Red Slip II (IV)—III (V). Besides, some sherds of Black Figured and Black Glazed Greek pottery are represented. The sherds of Type V are somewhat more numerous than those of the Type IV. This indicates that the end of Period 5 should be assigned to shortly after the middle of Cypro-Archaic II.

In Period 6 the potsherds of Type V are in the majority: White Painted and Bichrome V, Black-on-Red III (V), Bichrome Red II (V), Black Slip V, Red Slip III (V). Furthermore, a number of Black Figured, early Red Figured, and Black Glazed Greek potsherds are represented. No pottery of Type VI, was found, not even in the debris which covered the culture remains of Period 6 and was placed there at the beginning of Period 7 as a levelling layer for the floor of the temple of that period. Pottery of Type VI, on the other hand, is typical of Period 7. This seems, therefore, to indicate that the end of Period 6 approximately coincides with the end of Cypro-Archaic II.

Pottery of Type VI, as mentioned, is found in the strata of Period 7, and pottery of Type VII appears in Period 8: White Painted VI and Plain White VI—VII. Besides, numerous

sherds of Red Figured and Black Glazed Greek pottery are represented. As far as could be determined from the small fragments of the Red Figured pottery, specimens of the 5th century were found in the strata of Period 7, and specimens of the 4th century in the strata of Period 8. Finally, stray sherds of Black Lustrous Hellenistic pottery are found in Period 8. We may therefore infer that Periods 7 roughly corresponds to Cypro-Classic I and Period 8 to Cypro-Classic II. The latter period ends at the beginning of the Hellenistic epoch.

Periods 9—10 are characterized by Black and Red Lustrous, Black and Red Mat, and Plain White Hellenistic pottery, assigning these periods to the Hellenistic epoch. The coins found in the undisturbed strata of these periods agree with this dating: they are all Ptolemaic (except the coin No. 597, cf. p. 67).

We now proceed to the chronology of the finds. As pointed out in the Conditions of finds, this chronology can only to a small extent be based on stratigraphic evidence but in general one is referred to typological indications.

In the Conditions of finds the dating evidence for each object has been stated, and the reader is, therefore, referred to that chapter as regards the kind of evidence on which the objects are dated.

We start with the pottery. The Bichrome III jug No. 563 dates from Period 4, the Plain White V jug No. 562 from Period 6, the Plain White VII pottery Nos. 413, 481, and 511, which are typical of Cypro-Classic II, can be assigned to Period 8, the Red Figured Attic fragment No. 475 to Period 7, the Black and Red Lustrous, Black and Red Mat, and Plain White Hellenistic pottery Nos. 602, 603, 607, 612—617, 619, 620 to Period 9.

The chronology of the sculptures is entirely based on typological evidence. The archaeologically fixed points for dating them are given by the excavations in Ajia Irini (Vol. II, pp. 815 ff.) and Vouni (Vol. III, pp. 288 f.), and will be exhaustively dealt with in the comprehensive chapter on the chronological problems in Vol. IV.

On the basis of these chronologically fixed points we are able to assign the sculptures of Style I to the early or middle parts of Cypro-Archaic II, while those of Style II date from the latter part of Cypro-Archaic II. We may, therefore, attribute the sculptures of these styles to Periods 5 and 6.

Sculptures of Style III date from the end of Cypro-Archaic II and the beginning of Cypro-Classic I. Some of these sculptures may, therefore, belong to the end of Period 6, and others to the beginning of Period 7.

Sculptures of Style IV are typical of the remaining part of Cypro-Classic I, and they can accordingly be assigned to Period 7.

Sculptures of Style V are represented in Cypro-Classic II and those of Style VI at the beginning of the Cypro-Hellenistic period, and the sculptures of these styles can therefore be assigned to Period 8. As this period ends shortly after the beginning of the Hellenistic period, it is in accordance with this fact that only one sculpture of Style VI was found.

The chronology of the few objects of iron, bronze, lead, terracotta, faience, glass, stone, and bone is more difficult to establish within the same definite and narrow limits as the sculpt-

ures, inasmuch as they are not found in undisturbed layers, because the types of these objects are, as a rule, represented in more than one of the periods in question.

The faience beads No. 564 belong to Period 4; the bronze nail No. 578, the bronze coin No. 579 and the lead plaque No. 581, belong to Period 8; the ivory *stili* Nos. 1 and 568, the ivory bead No. 609, the iron pin No. 2, the lamps Nos. 3—5, 559, 601, 605, 606, the glass beads Nos. 6 and 611, the bronze coins Nos. 7, 596, 598, 604, 608, 610, the bronze chain No. 580, belong to Period 9.

All the other finds of these kinds of objects must be dated on typological evidence, in accordance with the conditions of finds as specified above, pp. 64 ff. These types of objects, however, are not so strictly limited from a chronological point of view as the styles of the sculptures, because the majority of the types are representative of more than one period. Their chronology must, therefore, as a rule, be less exact than that of the sculptures.

The lamp No. 98, the globular faience bead No. 196, the fragment of a bronze arrow-head No. 332, the glass bead No. 280, the piece of lead No. 281, the bronze nail No. 292, the conical terracotta cover No. 426, the fragment of a libation table No. 576, the architectural fragment No. 577, the iron lump No. 519, the indecipherable bronze coin No. 557, and the bronze lump No. 558, were found in the deposit pit together with the sculptures. Nothing in their shape indicates whether they are to be included among the earliest or latest objects of those deposited in the pit (Periods 5—8). On the whole, however, they probably date from Period 8, with the exception of the libation table fragment No. 516, because it seems unlikely that these small and unimportant objects were removed from *temenos* to *temenos* in the same way as the sculptures. The libation table, on the other hand, may very well have been successively removed from the earlier sanctuaries of Periods 5—7 to that of Period 8.

Of the objects found in the mixed debris close by, and below Platform 35, the spindle-whorl No. 567 cannot be later than Period 6, the bronze coins No. 554 a are Ptolemaic and consequently date from Periods 9—10, the bronze arrow-head No. 553, the bronze mountings Nos. 485, 554 c, d, the bronze nails Nos. 554 b, 565 and the piece of lead No. 554 e, may be from any one of Periods 5—8.

Of the objects found scattered in the debris of Periods 7—8, the iron knife No. 622, the bronze nails No. 599, and the ante capital No. 621 can be assigned to any of these periods, but the Cypriote capital No. 618 cannot be later than Period 6, and the style of the figural representation on the faience jug fragment No. 600 shows that it dates from Periods 5—6. These two latter objects must consequently have been removed from the sanctuaries of Periods 5—6 in the same way as the sculptures which is easily understood in view of their artistic quality.

The lamp No. 586 and the bronze coins, Nos. 588 and 589 a, b, d, e, found in the accumulation of disturbed earth outside Room 17, are Hellenistic and date, therefore, from Periods 9—10; the much corroded bronze coin No. 589 c may be from the time of Euagoras II, and would in that case belong to Period 8.

There remains the chronology of the objects found in the top debris, which could not be

connected with any definite period of habitation. Of these objects, the lamps Nos. 470—473, 555 are Roman, as is also the glass bottle No. 476. The bronze coin No. 597, struck by Tiberius, thus dates from the same period. The circular stone button No. 474, the piece of lead No. 556 and the architectural fragment No. 548 may be from any period, and the bronze coins Nos. 469 and 566 are indecipherable.

SUMMARY

The Acropolis of Kition began to be inhabited at the end of Late Cypriote III and the beginning of Cypro-Geometric I.

From this period to about the middle of Cypro-Archaic I (Periods 1—3) the architectural remains within the small area examined by us are probably of a secular character and consist of a house with rectangular walls, built of mud-bricks on foundations of rubble. The same house was in use during all this time, the floors being successively raised and the walls heightened.

About the middle of Cypro-Archaic I (Period 4) a temenos was founded on the debris of the earlier settlement. This temenos was in use until the beginning of Cypro-Archaic II, when a new temenos was built on top of it (Period 5). Towards the last part of Cypro-Archaic II this temenos was restored (Period 6). All these sanctuaries, as far as the architectural remains allow of judgement, were of the same type: a temenos with open votive and altar courts, and a roofed-in chapel, placed in a corner of the votive court. The *ex votos* consist mainly of sculptures. It should, however, be noted that no sculptures were found which can be attributed to the temenos of Period 4, and we may, therefore, infer that the *ex votos* were of a non-sculptural kind before Period 5, or have been removed to a place outside the area excavated.

At the end of Cypro-Archaic II a fourth temenos was erected on the same spot, but on a considerably higher level, resting on a thick layer of debris by which the temenos of Period 6 was covered. This new temenos of Cypro-Classic I was mainly of the same type as the previous one, but was built on a larger scale and of a more monumental design. It was surrounded by a solid peribolos wall of ashlar blocks and an inner temenos, rectangular in shape, was screened off within the peribolos area. The limits of the inner temenos are marked by a platform of limestone slabs, but no traces of a partition wall remain. Within the inner temenos there was a small and low altar, consisting of a square stone, and outside the same a rectangular pillar altar. The *ex votos* of Periods 5 and 6 were removed to this temenos and new votive sculptures were deposited there.

In the Cypro-Classic II period this temenos was restored and raised to a higher level. The *ex votos* of the earlier sanctuaries were removed to this, the fifth and last temenos, and two large, square altars were erected within its sacred area. In the beginning of the Hellenistic period the temenos was demolished and a large part of the *ex votos* were at the same time buried in a large, rectangular pit dug down through the debris of the inner temene of Periods

6 and 7, and partly down to the level of the temenos of Period 5. Afterwards the pit was filled in and its place marked by a platform of limestone slabs on top of the debris.

After the destruction of this temple the place was no longer used for sacred purposes, but in the Hellenistic period it was occupied by a secular house of store-rooms and workshops. For the subsequent history of the Kition acropolis no conclusive material has been obtained by our excavation.

There remains the question as to which god the temples were dedicated. No inscriptions were found elucidating this matter, but it can be solved on the evidence of some of the sculptures representing the god: I refer to the sculptures representing a god dressed in a lion's skin and with a club in his right, raised hand. This god is a Cypriote variety of the Greek Herakles, which the Phoenicians identified with their god Melkart, the city-god of Kition. In consequence of this it cannot be doubted that the remains of the temples excavated are those of the city-god of Kition. At the same time this affords an explanation that the temple was destroyed at the beginning of the Hellenistic period and never rebuilt. We know that Pumiathon, the last king of Kition, sided with Antigonos in the struggle between him and Ptolemaeus. He lost his life and throne, was captured by Seleucus in 312 B. C., and Kition ceased to be an independent state after Ptolemaeus' conquest of Cyprus. It is then natural to suppose that the temple of Melkart, the religious sign of the political independence of Kition, was destroyed at the same time, in the same way as the temple of the city-goddess Anat-Athena was destroyed when Idalion was conquered by Kition (cf. Vol. II, pp. 625, 628).

E. G.

V O U N I

INTRODUCTION

The remains of the ancient habitation of Vouni on the N. W. coast of Cyprus, though they were hardly visible above the ground, have attracted the attention of several travellers. They are set out on the map of Cyprus drawn by Lord Kitchener. Cesnola visited the site (*Cyprus*, etc., p. 231) and identified it, like other travellers, with the ancient Aipeia, a city which should have existed before Soli, and mentioned by Plutarch (*Sol.*, 26). Pockock, however, in 1745, does not seem to have associated the ruins at Vouni with Aipeia, as he mentions a village called Epe, situated in the mountains above Soli, which he explains as being derived from the ancient name. In 1837 E. Oberhummer, accompanied by Ohnefalsch-Richter, passed over Vouni and accepted the identification of Cesnola (Pauly-Wissowa, *Realenc.*, art. *Soli*). The theory that Aipeia should have been situated on the summit of Vouni is only based on the fact that the name Aipeia fits the topography of the site which is really provided with very steep slopes, and the situation seems to tally with Plutarch's quotation. As the excavations undertaken on the place by the Swedish Expedition, however, did not reveal the slightest material which could be dated to a period earlier than the 5th Century B. C., the theory proved to be wrong. On the contrary, the whole habitation of Vouni must be associated with a much later epoch in the history of Soli, as will be demonstrated in the ensuing pages, and the site of Aipeia has to be sought for elsewhere.

The excavations at Vouni were started in the spring of 1928, and were continued until the autumn of 1929. Subsequently, supplementary diggings were made on sundry occasions in connexion with the analysis of the architectural remains and the attempts made in order to obtain as accurate datings as possible of the various periods.

Topography

(Figs. 31—36; Plan VII)

Vouni is the local name of a rocky hill which rises directly from the sea about 4 miles N. W. of the ancient city of Soli. A traveller riding from Nicosia to the W. will see the characteristic contour of Vouni in front of him as soon as he has passed the village of Peri-

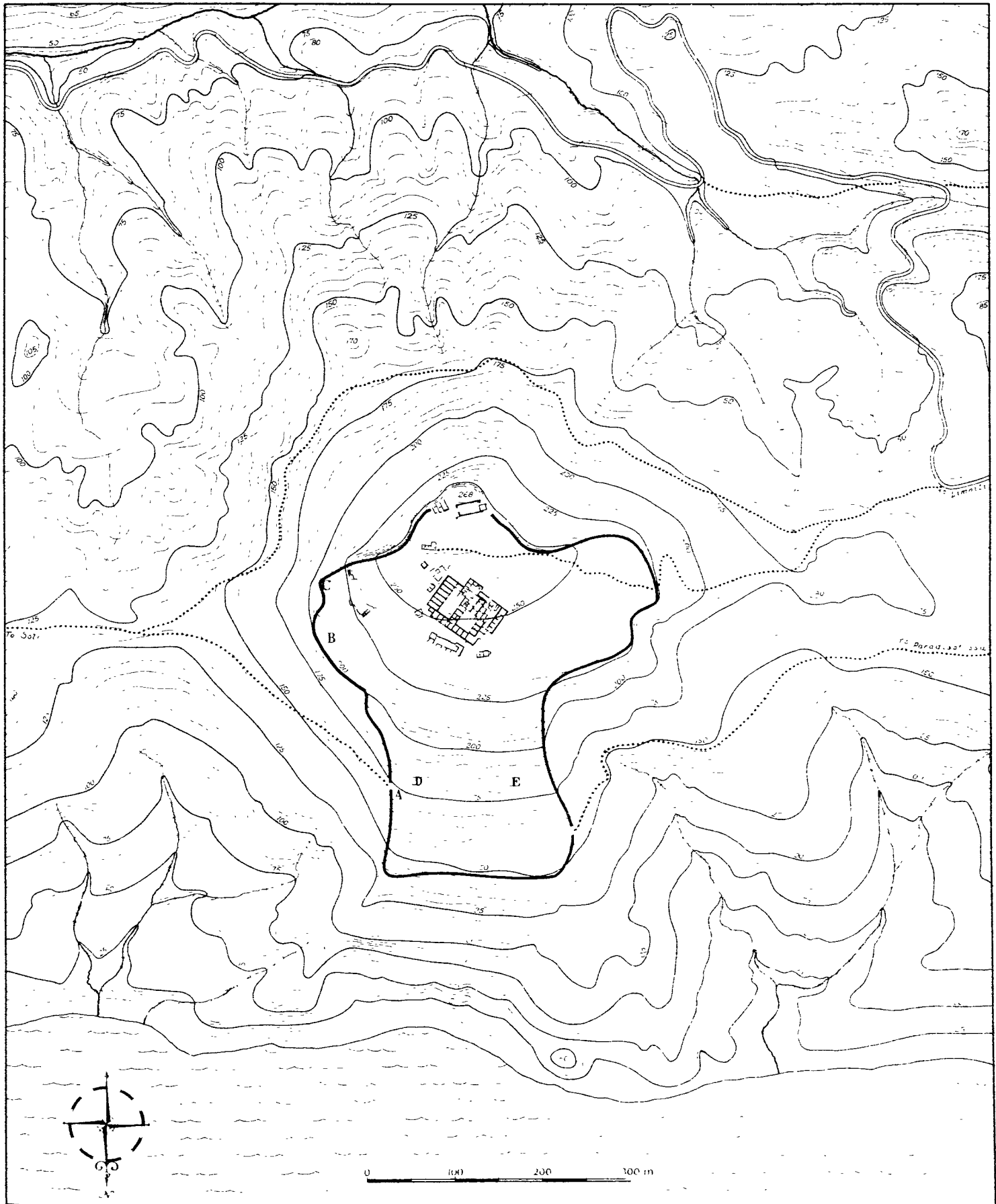



sterona. Also from the mountains of Troodos the hill is recognized a long way off in spite of its not being higher than 268 m. This is due to the fact that Vouni is isolated from other mountain ranges, and stands out as a separate hill with steep sides all round. The nearest connexion with other mountains is on the W., with the wild, rocky landscape along the N. W. coast of Cyprus. In reality Vouni may be considered as one of the easternmost spurs of these mountains.

It is evident that the nature of the steep rock itself, and the position of it not far from the western boundary of the plain of Mesaorea, close to the sea, and with good communications with the interior, should make the place extremely suitable for a fortress at its top.

In close vicinity to the hill there exist several remains, indicating the way in which the roads in ancient times were constructed. There must certainly have been good communications with Soli, to the E., and Marion, via Limnitis, to the W. There are also traces of another road to the south of the hill, running across the rill, straight up on the opposite slope of the valley. The ancient road from Soli can be traced more or less the whole way from the western city gate of Soli through the site of Cholades (cf. p. 416) and behind the low ridges along the coast to Mersinaki (cf. p. 340). From the N. W. part of the plain of Mersinaki the road continues almost in a straight line up the eastern slope of Vouni. It is here visible for short distances as a trench in the rock. Just where the incline to the top-plateau begins, the ancient road seems to have been laid out in the same direction as a modern path on a ridge with steep slopes on either side, towards the sea and, on the other side, to the S. At A on Plan VII the road passed through a gate in the rampart, and turned sharply to the S. It runs here more or less horizontally on the side of the hill to a vast area B, at about 200 m. above sea-level. This area is enclosed on three sides by the rampart, and is limited on the W. by the vertical rock wall. The various stairs which lead up from the area B to the upper plateau will be described below.

The ancient road leading up to Vouni from the W. seems to have come from the site of Limnitis. In all probability one road followed the same valley as the modern one, but there seems also to have existed another road much nearer to the sea, and parallel with the shore. At present, there is a minor path passing the site of Paradisotissa, about 1.5 km. W. of Vouni. Between Paradisotissa and Limnitis the path runs across some more or less horizontal plateaus with traces of ancient habitations. The potsherds found in these fields seem to indicate that these houses existed contemporaneously with, or slightly later than, the constructions of Vouni. No doubt the western ascent of the hill was situated in ancient times along the same ridge as at present. How much of the foundations for the modern path on the slope of Vouni might be remains of an ancient road, is uncertain. The path runs, however, after a few sharp turnings, straight up to a gate in the ramparts, still traceable on this side. There might possibly have been another branch of this ancient road running to the lower, northern part of the hill, called Loures (cf. p. 291).

An ancient road seems to have existed about 200 m. from the shore, passing on the very steep slopes of the N. side of the hill, evidently outside the ramparts. The road has altogether vanished but remains of bridges over the brooks N. E. (at Androuklies) and N. W.



Fig. 30. View of Vouni from the West.

(at Kakotriches) of the hill indicate the previous existence of the road. The bridge-heads can be distinguished, though with difficulty, made up of large, white limestone rubble sunk down in the dark rock on either side of the rill. The white limestone is foreign to this place. The remnants of the bridges have been washed away by the rills. Another ancient bridge is better preserved at a place called Lakshes tou Nikola, S. of the summit of Vouni, in the deep valley close to the road. Here, the northern bridge-head is fairly well preserved, consisting of a high wall built against the vertical rock. The wall, which served as a support for the bridge-arch is constructed of large, irregular rubble, sometimes carelessly hewn, and wedged in position with smaller chips. This bridge seems to have carried the traffic over the rill up to the region of the villages Galini and Varisia, a tract which was inhabited also in ancient times, as can be proved by the vast necropoleis.

The topography of the sites Mersinaki and Paradisotissa will be described on other pages, and likewise the situation of the western necropolis of Vouni. We shall now proceed to the remains on the top-plateau of Vouni within the ramparts. The latter can be traced in the earth more or less all round the edge of the plateau, which is very distinct and thus offers a natural position for a defensive wall. In reality this seems to explain all the irregularities in the plan of the wall. On the very summit there are no remains of the wall left due to the weathering of the rock. Evidently parts of the rock-edge have fallen down together with the rampart built upon it. W. of the summit the wall is clearly discernible where it runs along the edge which is somewhat curved.



Fig. 31. View of Vouni from the acropolis hill of Soli.

After passing a large tower, the foundations of which could be traced in the soil, the wall continues on the western side of the hill. Here it is hidden entirely by debris but by means of diggings its situation could be ascertained. It seems to have followed the very edge of the plateau, which also is the natural way of solving the defensive problems on this part of the hill, as the sides here are very steep. In mighty curves the wall runs down the slope in the direction of the sea. The wall towards the sea has vanished almost entirely, but remains of it can be seen about 150 m. above sea-level just where the slope begins to be almost vertical. The N. E. corner of the rampart is easily distinguished on a promontory of the rock whence the wall turns to the S. following the natural rock-edge. At the point where the road from Soli reaches the rampart some very large limestone blocks indicate the previous existence of a gate in the wall. The edge is not so distinctly marked on this spot, and the wall does not run as previously on top of the plateau but turns to the S. E. downward on the slope so that there is place for a wide road between the rampart and the almost vertical side. Further to the S. E. the wall encloses an oblong plateau (B) situated 200 m. above sea-level and about 25 m. below the upper plateau. To the S. this lower plateau was defended by a strong, square tower, at C. on Plan VII. The S. E. side of Vouni is very steep. Just below the top plateau the side consists of a vertical wall about 30 m. high. Naturally this has been made use of in connexion with the ramparts, which consequently are continued just above this precipice. Its continuation originally met the rampart on the S. W. side. On the very top, however, large pieces of the rock have fallen down so that no remains of the ramparts are



Fig. 32. Vouni from the South.



Fig. 33. Vouni. View towards the South from the summit.

left there. The destruction of the rock is due to special conditions. On the top-plateau the surface layer of the rock, about one metre thick, is very hard. Below this, the rock is much softer and crumbles easily. The marked edge of the top-plateau is caused by the rock on the sides crumbling and being eroded, while the crust on the surface has resisted the destruction. In places weather and wind have hollowed out large caves below the hard surface layer, which in this way becomes undermined.

Within the ramparts, the space is divided in a very significant way. The area on the very top, to the S., is reserved for the temple of Athena (cf. below); on the second largest terrace is situated the palace, surrounded by various minor sanctuaries or chapels. The palace area does not seem to have been separated from the sanctuary of Athena by any kind of wall or other construction. To the N., however, the palace area is delimited by means of a strong, high terraced wall which must have hidden the greater part of the palace from view of anyone standing on the steep northern slope of the hill. This terrace wall follows the contour about 240 m. above sea-level, and close to it there are no remains of buildings. Between the contours 225 and 190 m. above sea-level some rock-tombs were found. Most of them were open like caves and the steep slope made the usual dromos superfluous, so that one could enter the tombs directly from the doorways. This necropolis is situated like a narrow band across the slope from the western to the eastern ramparts. By reason of the position of the



Fig. 34. Vouni. View of the plane of Soli from the summit. In the foreground, left, the site of Mersinaki.

tombs in a steep slope all the contents had as a rule been removed. Below the strip of tombs the area enclosed by the ramparts was occupied by houses of a character similar to the palace. Several of the houses were trenched over, and the results of these diggings will be described in the ensuing (p. 291). On summing up the results of this investigation as to the use of the various parts of the area enclosed by the ramparts, the following characteristic features will be noted: in the very centre of the area is situated the royal palace, surrounded on three sides by many minor sanctuaries or chapels; on the fourth side, on the very top of the hill, the large temenos of Athena is placed. The roof of this temple would have been visible a very long way off. A strip of tombs or necropolis has separated this upper area with the palace and the various temples from the rest of the habitation on the hill, which is located on the lowest part within the ramparts. Owing to the steep slope of this side of the hill, the palace could neither have been seen from these houses nor could the latter have been visible from the palace. Communication between the various portions took place by a multitude of narrow roads excavated in the rock or laid out on foundations of large rubble, and running in an E.—W. direction. In a N.—S. direction, the steep slope made stairs necessary. Stairs are also noted on various points, cut in the solid rock or built of oblong ashlar. It seems to have been impossible to drive a chariot within the ramparts, with the exception of the area B. and the road up to it from the afore-said Soli-gate. In reality, area B may have been just the parking-place for the chariots coming from the E. It would have been possible

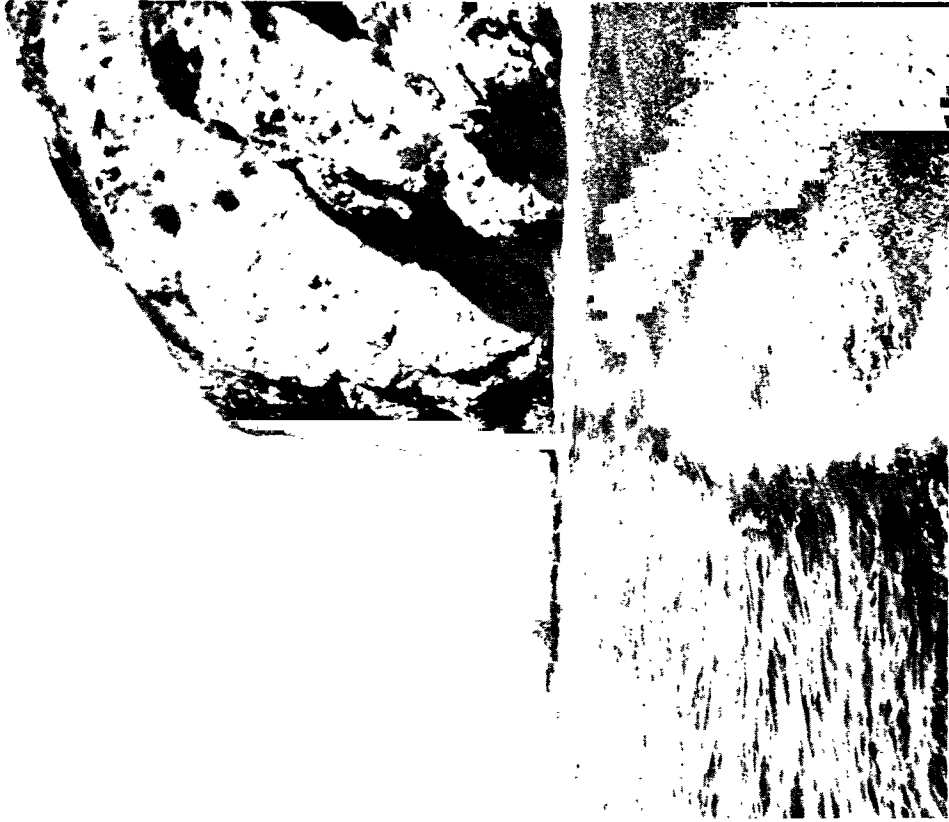

Fig. 36. Voumi. On the shore.

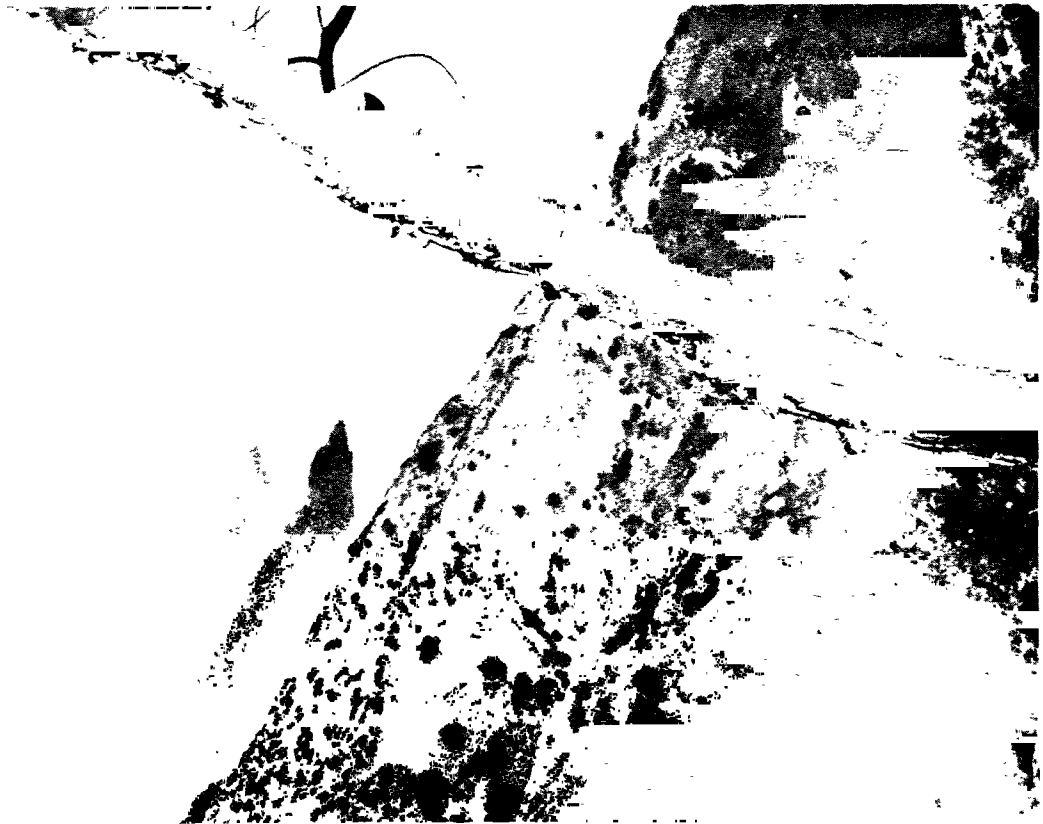

Fig. 35. Voumi. View of Petra tou Limmniti from the slope of the hill.

to pass through the gate to the lower part of the city but the palace could never have been reached by means of chariots from the said gate.

The area B was, as far as could be ascertained, provided with a spacious cement floor. As no diggings were made here it is impossible to describe in detail the nature of the constructions. To the W., the space was limited by the rock wall, which had evidently been cut vertically for a distance of about 150 m. The northern portion of this purposely levelled wall has partly fallen down, but the southern end seems to be fairly well preserved in its original state. Communication between the area B and the central region with the palace and the sanctuaries was by means of stairs cut in the rock-wall. Three separate stairs can be clearly distinguished, but there might have been others, on the northern part of the rock-wall, which have fallen down. Large pieces of rock are noted on the area B or near it, and on many of them traces of the stairs are distinguishable in the shape of step cut on one side. The conditions in connexion with the stairs will be described and we shall start with the southernmost one.

This stair must have started just inside the rampart. The rock-wall is here about 25 m. high. Unfortunately, only very scanty remains of the steps are preserved. Evidently, they were cut in the rock leading from the S. up to the N. The stair reaches a kind of a small vestibule just on the edge of the rock, the eastern portion of it being destroyed. This small room is entered from the S. through a doorway, 1.25 m. wide, with jambs cut out of the rock. The western jamb is 1.75 m. high, while the eastern one measures only 0.70 m. The vestibule is oblong in plan, the walls being excavated in the rock. From its northern short wall a small stair starts, 0.65 m. wide, and cut in the solid rock. It turns to the left and leads up to a kind of ramp, 4.0 m. wide, and running at right angles to the afore-said rock-edge. The ramp ascends sharply to a road running in a S.—N. direction, parallel to the rock-edge. The road is cut in the rock for a distance of about 50 m. At the N. end it meets other, similar roads which join in a large stair, leading up to the palace area. The small vestibule mentioned above is sheltered by a deep furrow cut in the rock. In this the rain-water is collected and carried away from the vestibule and the stair.

About 20 m. N. of the vestibule there are remains of a similar stair on the rock wall, also leading up from the area B to the palace area. The lower parts of the stair are totally destroyed but just below the upper edge four steps are partly preserved. They lead directly, without any kind of vestibule, up to a road cut in the rock very near the precipice, and parallel with the other, 50 m. long road.

While the two stairs on the rock-wall, described in the preceding are situated S. of the main road to the palace area, the third stair is found about 80 m. N. of it. This stair is not like the previous ones, which, as far as could be ascertained, had the steps running straight up along the rock wall. The third stair, however, is composed of various portions arranged as an irregular shift staircase, following the irregularities of the rock. The steps are about one metre wide and turn after 5—6 steps. The uppermost steps lead to a vestibule similar to that of the first stair. The entrance into the vestibule, however, is not on one of the ends but in the middle of the eastern side. The way continues through the S. end by means of

a road, parallel with the rock edge, and cut in the rock. It meets the other two roads along the rock-edge and joins the large entrance into the palace area.

This begins just above the rock-edge where a large stair was noted, laid out of well hewn ashlar.

The road leads close to the vicinity of the palace. The left side of it is cut in the rock, while the right side must have had foundations of large rubble, which has now partly disappeared. This road continues on the S. side of the palace, just above the temenos, constituted by Rooms 120—124. The way in which the various constructions around the palace were connected with roads will be described below.

A. W.

The temple of Athena

At the very summit of the hill the remnants of some much destroyed constructions were cleared. As the ground is very much exposed to weather and wind, and not sheltered by any trees or bushes, the soil which once had accumulated between the walls and in the deeper parts of the rock had easily been blown away. A great deal of the debris from the buildings had also been washed away by the rain. In consequence of this, only the lowermost portions of the walls were left, and the soil between them was only occasionally undisturbed. A triangular space on the summit was cleared in the summer of 1928, and the architectural remains within this excavated area were examined.

ARCHITECTURE (Plan VIII)

The architectural remains consisted of foundation walls and floors of various constructions and compositions. Besides some bases for statues and altar were noted, which might have been more or less connected with the architecture. The construction of the walls will be clear from the following descriptions. They all belonged to types well illustrated in the royal palace. In a few cases the local conditions and the rough bedrock may have caused some variations in the types mentioned.

ARCHITECTURAL ELEMENTS (FIGS. 37—46)

W a l l s.

Wall 1.

Width: 0.70 m. Height: 1.00 m.

This wall constitutes the rear of a square room to the E. of it. It is erected on the solid rock which here slopes towards the W. In order to level the ground, a solid foundation is laid consisting of 1—2 courses of ashlar kept together with gypsum mortar. Also smaller flat stones are used in order to level the upper face of this foundation wall, on which the upper portion is erected. As regards this, two parts are noted, the lower one consisting



Fig. 37. Vouni. The temple of Athena. Room II.

of ashlar raised on edge to make an irregular box-wall construction (cf. below), the upper part consists of irregular rubble fixed with gypsum mortar. The E. face of the wall is plastered with a thick layer of hard gypsum. The S. portion of the wall is destroyed and partly missing.

Wall 2.

Width: 0.65 m. Height: 0.50 m.

Here the construction is similar to that in the previous wall. But the foundation of ashlar is superfluous as the rock is much higher on this side. The rock has been made use of as part of the wall and is therefore cut to the same width as the wall. The wall resembles the uppermost part of Wall 1. The N. face of the wall was plastered with a layer of crystalline gypsum similar to that in the floor of Room I (cf. below).

Wall 3.

Width: 0.65 m. Height: 1.00 m.

This wall is of the same construction as Wall 1, with the exception that the ashlar in the foundation project below or overlap each other like the steps in a stair. In the middle, the foundation portion is superfluous as the rock here comes up rather high. The course of box-wall construction extends up to the floor of Room I.

Wall 4.

Width: 0.70 m. Height: 0.60 m.

This is the E. wall of Room I. As far as can be seen it had the same construction as Wall 2. The ashlar are very irregularly laid on the inside. On the outside, there is a row of ashlar, two courses on the N. end of the wall, which are laid close to the wall. They

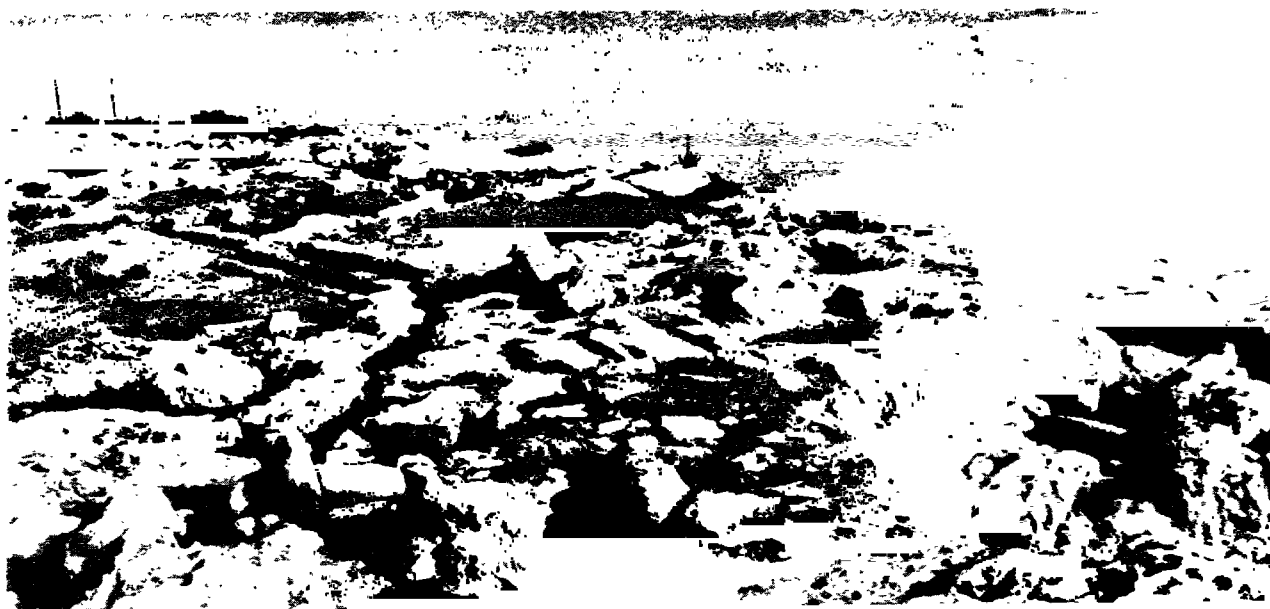

Fig. 38. Vouni. The temple of Athena. E. portion.

are kept together with gypsum mortar. Through a line on the gypsum it is possible to determine the original floor-level of Room II (cf. Fig. 40). Not in the middle, but placed a trifle to the S. on this wall, a doorway can be distinguished, the jambs of which might have been placed on low foundations just inside the doorway. All the walls 1—4 seem to have been bonded to each other (Figs. 40 and 41).

Wall 5. Width: 2.20 m. Height: 0.15—1.00 m.

This wall constitutes the northern limit of the large rectangular area called Room II. The extremely solid construction seems to indicate that the wall was built in order to retain a terrace whose upper surface was indicated on the E. face of Wall 4. Evidently the wall was much higher originally. It is founded on the solid rock and consists in its present state of roughly hewn ashlar of various sizes in a flat position. As a rule, three ashlar correspond to the whole width of the wall. The stones are fixed with a great quantity of gypsum mortar. The joint between this wall and Walls 3—4 is of great importance for the question as to the joint between Room I and Room II. As far as could be seen, Wall 5 was originally connected with Wall 7 by means of Wall 6 which was removed almost totally in order to give place to Room I. The latter was added so that Walls 3—4 abut against the W. end of Wall 5. Some ashlar placed on edge were oriented in accordance with the extent of Wall 3, and aligned with the S. face of that wall.

Wall 6. Width: 2.20 m. Height: 0.85 m.

As has been described above this wall has been destroyed so that only a very short fragment of it is preserved, the original full extent being between Walls 5 and 7. The fragment preserved indicates that the wall was constructed on the box-wall principle (cf. p. 128).



Fig. 39. Vouni. The entrance into the sanctuary of Athena.



Fig. 40. Vouni. The temple of Athena. The floor-level of Room II indicated on the façade of Wall 3 of the sanctuary.

It is founded on the solid rock, and was at least bonded with Wall 7 and probably, originally, also with Wall 5. Only one course of raised ashlar is preserved.

Wall 7.

Width: 2.20 m. Height: 0.20—1.00 m.

This corresponds to Wall 5 to which it is parallel. Its construction is to a great extent determined by the surface of the rock which is here very uneven and full of cavities alternating with higher portions. As to the masonry, it differs from Wall 5. In the eastern portion, however, the construction of the wall is more or less of the same nature. The western part of the wall shows some peculiar features as regards the arrangement of the ashlar, which probably should be a variety of the box-wall type, possibly in order to strengthen the wall. The raised ashlar are often double, and sometimes the whole "box" is filled with raised ashlar. The whole is founded on a core of gypsum mortar on the solid rock. The wall is clearly bonded with Walls 6 and 8.

Wall 8.

Width: 2.00 m. Height: 0.30—0.65 m.

The large rectangular area within Walls 5—7 is shut off on the E. by Wall 8. It is of the same construction as Wall 5, on to which the N. end abuts. In the middle of the wall there is an entrance, about 4 m. wide. Possibly a flat stone on the N. side near the jamb may have been a part of a threshold. In that case there must have been a sloping ramp from this entrance up to the level of the terrace. The rock in the middle of the entrance, immediately W. of it, is very rough and there was no sign of a level surface anywhere in the soil.

Wall 9.

Width: 0.70 m. Height: 0.80 m.

This wall consists of shells of raised ashlar with a core of small rubble. Part of it is founded on the rock, while the rest is placed on the bottom layer, consisting of dark-red earth. The wall abuts loosely on to the end of Wall 5, and is connected with a kind of platform made

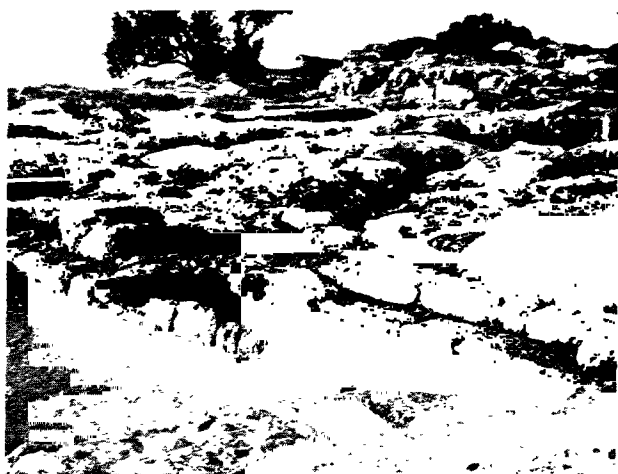

Fig. 41. Vouni. The temple of Athena. The entrance between Rooms III and IV.



Fig. 42. Vouni. The temple of Athena. Stair 19 from the East.

of rubble lined with raised ashlars. The platform may have served as a base for sculptures while the wall constitutes the northern limitation of a courtyard to Room II.

Wall 10.

Width: 0.95 m. Height: 0.20 m.

This is so much despoiled that the construction of the wall can hardly be distinguished. Only a line of rubble along the edge of the floor of Room V indicates the extent of the wall. The outside of it is marked by a raised ashlar.

Wall 11.

Width: 1.00 m. Height: 0.10—0.60 m.

This wall separates Room V from Room VI. It is laid of large roughly hewn ashlar of local hard stone. They are placed as shells on either side of the core of rubble chips. No blocks preserved are in the S. part but the wall can be traced by the solid rock which continues the wall foundation to the S. Evidently, the wall originally extended to the edge of the plateau.

Wall 12.

Width: 0.65 m. Height: 0.60 m.

This is a very short piece of wall, which may have extended across Room VI. It consists of shells of raised ashlars and a core of rubble chips. The wall abuts on to Wall 11.

Wall 13.

Width: 0.85 m. Height: 0.65 m.

The wall abuts on to Wall 11 and is constructed of rubble placed on the rock, with a course of ashlar laid on top of it. The E. portion of the wall is occupied by an entrance marked by a row of lying ashlar placed on debris.

Wall 14.

Width: 0.80 m. Height: 0.15—1.10 m.

This seems to be a continuation of the previous wall with which it is bonded. It consists of rubble founded on the rock, and is preserved in three courses.



Fig. 43. Vouni. The temple of Athena. Altar 20.



Fig. 44. Vouni. The temple of Athena. Joint between Walls 3 and 5.

Walls 15—17.

Width: 0.75 m. Height: 0.10—0.45 m.

These are of the same construction, irregular rubble founded on the rock. The walls are very much destroyed. In the W. end of Wall 15, a doorway can be distinguished. The wall was not bonded with Wall 14.

Stairs.

It is possible that stairs were used on several occasions between the various planes within the sanctuary but they are preserved only in a couple of cases.

Stair 18.

To pass from Room IV to Room III there were two steps partly cut out in the rock but finished off lying ashlar of soft, local rock. The stair is 2.80 m. wide. About one m. E. of the lowest step there was a row of raised flat stones which may be explained as the real threshold of the entrance. These stones were placed in the floor-filling of Room IV and up to the level of this (Fig. 41).

Stair 19.

This leads up from Room IV to Room V. It occupies the whole width of Wall 11. The stair consists of three steps of lying ashlar which evidently were covered with a layer of concrete.

Altar.

Altar 20.

The only construction which with any degree of certainty can be explained as an altar is situated close to Wall 8 on the floor of Room III, N. of the entrance through the wall. The altar is founded on a layer of dark earth, and consists of a core of irregular rubble kept together with gypsum which is plastered on the sides in several layers. The upper part of the altar is damaged (Fig. 43).

VOUNI

Temple of Athena

Architectural plan

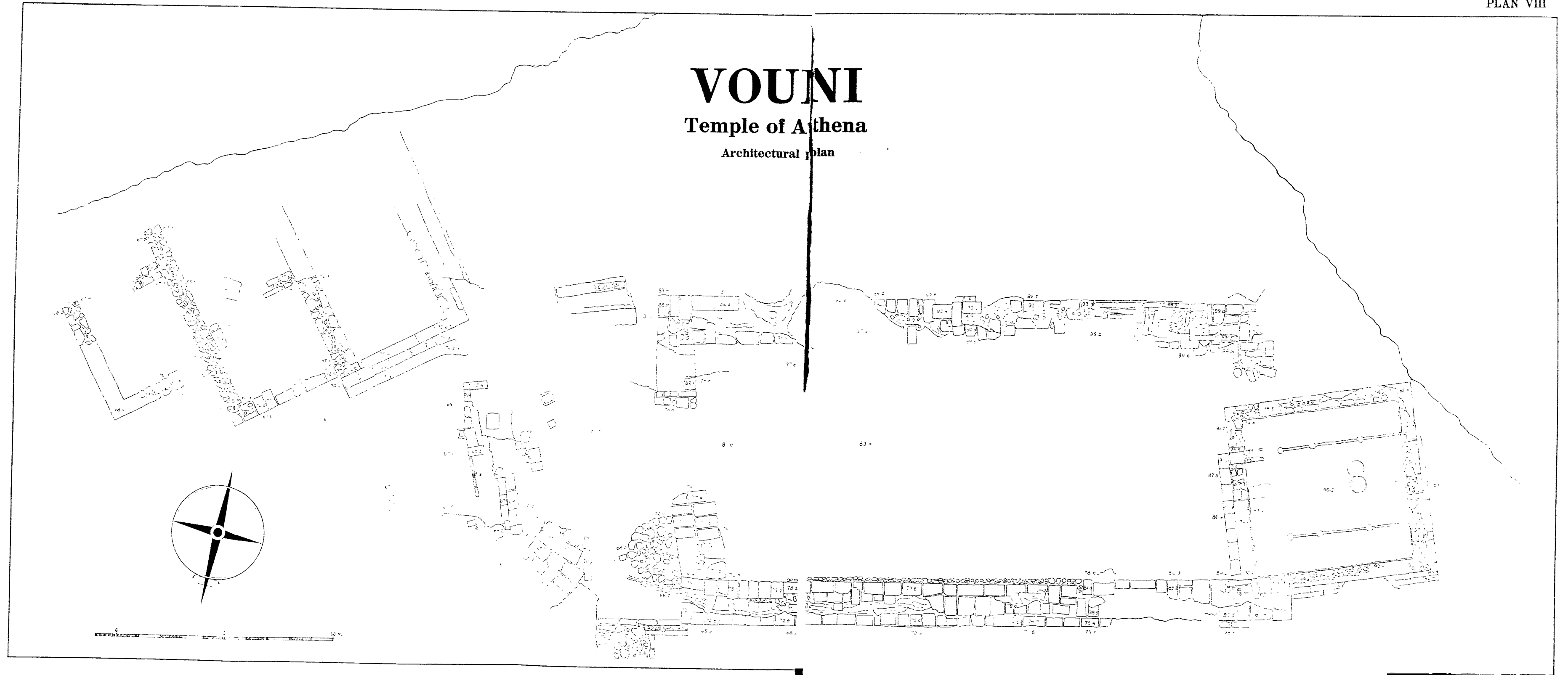



FLOORS.

The floor of Room I is laid out on a foundation of small limestone chips. Just below the floor the chips are flat, about 20 cm. wide. The floor rests on this foundation. It consists of a layer of gypsum, about 5—10 cm. thick, containing large crystals. The floor is comparatively well preserved. Somewhat beside the centre, there is a hole shaped like two intersecting circles. This was filled with limestone chips down to the rock, about 40 cm. below the floor. This was possibly the place of an altar or a base for a statue. The floor is divided into three portions by grooves forming traces of walls, evidently wooden, which had been sunk down in the floor; the centre portion is the largest. These two wooden walls started at Wall 1 but never reached Wall 4. In this way entrances were left between the middle and the side portions of Room I which are called A, B, and C. The wooden walls were symmetrically strengthened by each three posts, the positions of which were clearly discernible in the floor.

The large area of Room II must have changed considerably since the temple was in use. The natural rock is nowhere levelled off in connexion with a floor or anything similar, and the earth found above it could not supply any information as to the level or position of the original floor. We are therefore confined to the architectural remains. The powerful walls which limit the area indicate that they are meant for enclosing an artificial plateau or terrace. On the other hand the doorsill-stones in the gate of Wall 8 indicate the floor-level at the entrance into the space from the E. This doorsill-stone is situated at level 78.0. In the W. the level of the original floor is clearly marked on the east façade of Wall 4 where a distinct line in the gypsum revetment is noted (Fig. 41). This line is on level 88.0. There is thus a difference of 1.0 m. between the floor in the E. and in the W. Apparently the floor of Room II sloped from the higher western to the lower eastern part. As to the construction and nature of the floor, nothing can be ascertained, since nothing is preserved of it but this latter circumstance may indicate that the floor was an earthen one, and that the whole area had an uneven surface. This is also confirmed by the fact that the rock in the S. E. projects with rather high portions.

The floor of Room III varies as to its construction, and parts are not discoverable. The best preserved part is located to the N. where the floor consists of large ashlar laid out in an irregular pattern. At the sides of the ashlar, the rock is levelled off. The same treatment is noted also in the southern parts where the floor is formed by the natural rock which has been made even. In the middle, between the entrances into Rooms III and II, the floor consists of hard white concrete, rather coarse in its consistency. The concrete is laid on a layer of debris.

The floor of Room IV has a loose consistency. It is laid on a layer of debris, and closely connected with the steps of Stair 19. The floor consists of grey concrete mixed with gravel.

The floor of Room V is fairly well preserved. It consists of red, burnt clay, more or less like red concrete. The surface itself was covered with a thin layer of cement or concrete. The foundation for the floor consists of dark-red earth. The eastern portions of the floor are damaged.

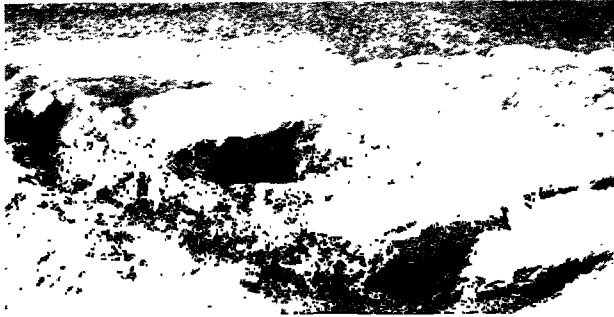

Fig. 45. Vouni. The sanctuary of Athena (Room I),
N. E. corner, floor removed.

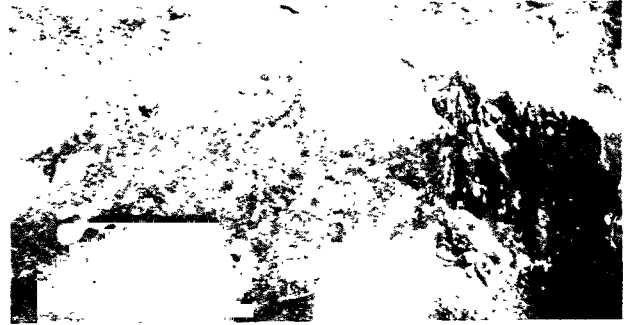

Fig. 46. Vouni. The temple of Athena. Layers
near Wall 9.

In Room VI no real floor could be distinguished, nor could the floor-level be determined from horizontal lines marked on the sides of the walls. In the eastern parts of the room, however, the natural rock is levelled, and it is likely that this marks the original floor-level.

In Room VII, only a very small fragment of the floor was preserved close to Wall 14. This consisted of white concrete laid on a layer of dark earth. Probably the floor was the same all over the room.

Bases for statues.

In Room III, which might have been a small open courtyard or forecourt to the large, rectangular court, Room II, various bases for sculptures were found, some of them being placed in niches in the rock. In other cases only the square depressions remained. As far as could be seen the statues had been placed without any special order, and the fronts of the sculptures had been in different directions. Most of these bases were found just inside the entrance, above Stair 18. East of the wall-corner 7—8 there is a rectangular depression in the rock in which was placed a row of hard ashlar. N. of this, there are other cuttings in the rock indicating that other structures had been removed. It seems likely that this part corresponds to Wall 9, and its enlargement on the N. of the courtyard, and that the row of ashlar indicates the southern limitation of it. In that case the depressions in the rock in front of the ashlar may be explained as places in which bases for statues were once placed. Of course, there is reason to believe that sculptures were placed also on the floor of Room II, but as this floor is not preserved there are no remains of the bases nor their original place.

STRATIFICATION

As has been mentioned before, most of the earth from the site had blown away or washed away by the rain. For the same reason it is clear that many of the strata had been removed or mixed, and that the finds in the earth, therefore, in many cases might have originated from other places in the vicinity. As a general rule the stratification was very simple. On a few occasions only the depth of the earth was more than 1.50 m. Some of the layers were recognized all over the site. Thus, below the usual surface layer, 15 cm. thick, there followed a layer

of brown or grey, homogeneous earth which rested on a stratum of dark-red virgin soil that filled most of the cavities in the rock. This was the rule for the stratification. On several occasions, however, special conditions made it more complicated. This was the case in the localities connected with the construction of Room I; furthermore, as regards the layers below the western portion of Wall 7 and the conditions of earth connected with Wall 9. Finally, the stratification below the floor of Room VI was found to show slight changes from the layers mentioned above.

The floor of Room I was covered by a layer of debris consisting of pieces of the walls and the roof structure of the building. The same layer extended outside the building, especially on the N. side where a triangular layer was visible in a section. Below the floor of Room I the stratification was examined only in the eastern part. Here the floor was removed on a square of 2.0 m. The layers below the floor consisted of a filling of brown earth, containing a few potsherds. On the rock was a thin layer of dark-red virgin soil.

Below the western portion of Wall 7 was found a pit filled with foreign layers which deserve description. The wall has been erected across the pit so that the layers were recognized on either side of the wall. Evidently all the finds in the pit must belong to a period prior to the wall, but the pit might have been arranged in connexion with its construction. Below the surface layer there follows a stratum of light-brown earth, fairly homogeneous in consistency. This is about 0.45 m. thick. On either side of the wall this layer rested on a heavy stratum containing plenty of charcoal and ash, together with minor lumps of earth. In this, a great many finds were made. The layer was 10—15 cm. thick and rested on dark-red, virgin soil.

Between the altar (20) and Wall 9, the layers deserve some explanation (Fig. 46). The altar was laid on the foundation of dark-red bottom earth. Through this, a foundation trench for Wall 9 was dug down to the rock. The trench was filled with white, hard earth containing a quantity of gypsum which was found just below Wall 9. The rest of the trench was filled with brown earth mixed with lumps of white gypsum.

As to Room VI, it seems impossible to ascertain whether the layers in which the finds were made should be regarded as foundations for the floor in the room or if they were originally placed on the floor. The latter seems to be the most natural explanation. At any rate, no differentiation in the earth could be distinguished to indicate on which level the floor had been.

ARCHITECTURAL ANALYSIS AND SYNTHESIS

A glance at the map will be sufficient to show that the architecture of the place could be divided in three distinctly separate portions. The first one is constituted by the square building Room I enclosed by Walls 1—4; the second, Room II enclosed by Walls 5—8. To this latter is added a small fore-court, Room III. Furthermore, there is a third part, Rooms V—VII, which together make a block of houses built together. The question whether all these structures belong to one and the same period, or if they must be ascribed to different epochs, cannot possibly be settled definitely, but weighty reasons indicate that one has

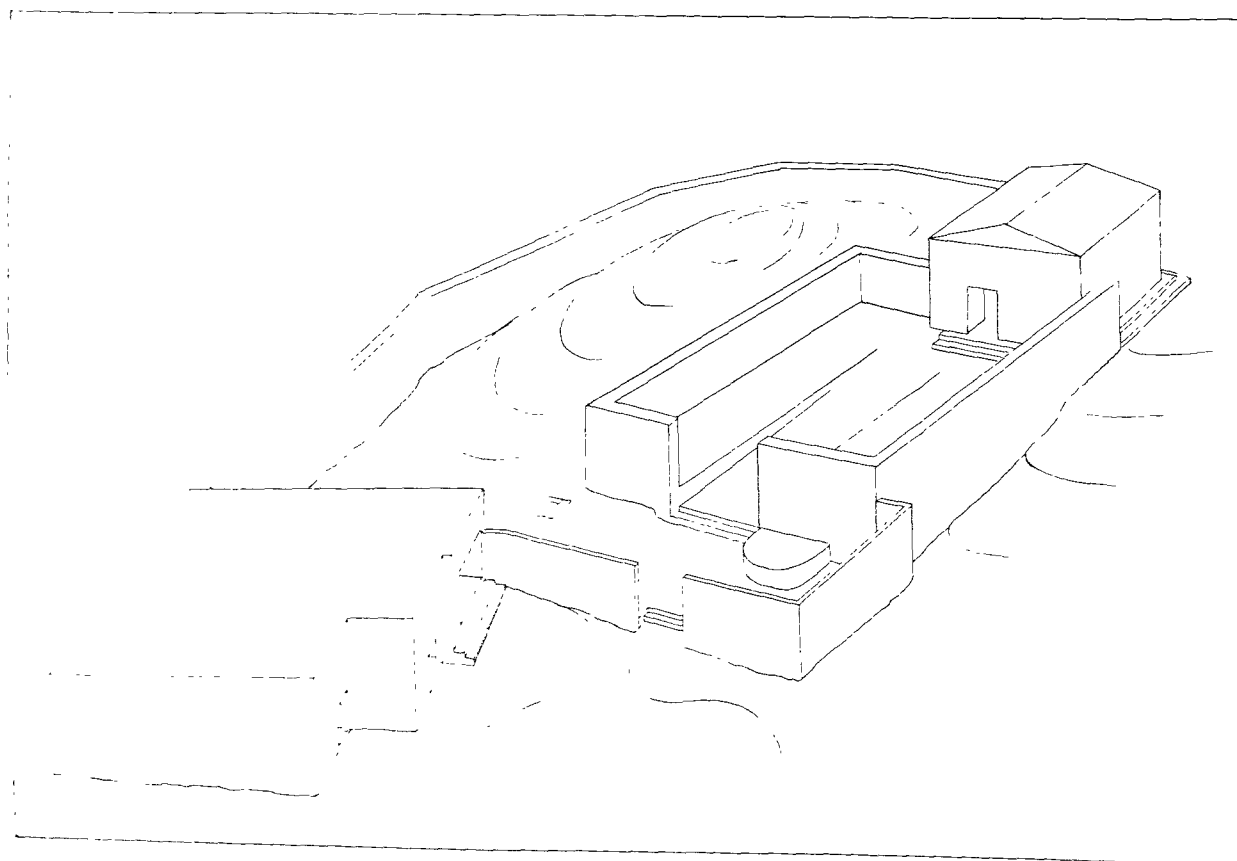
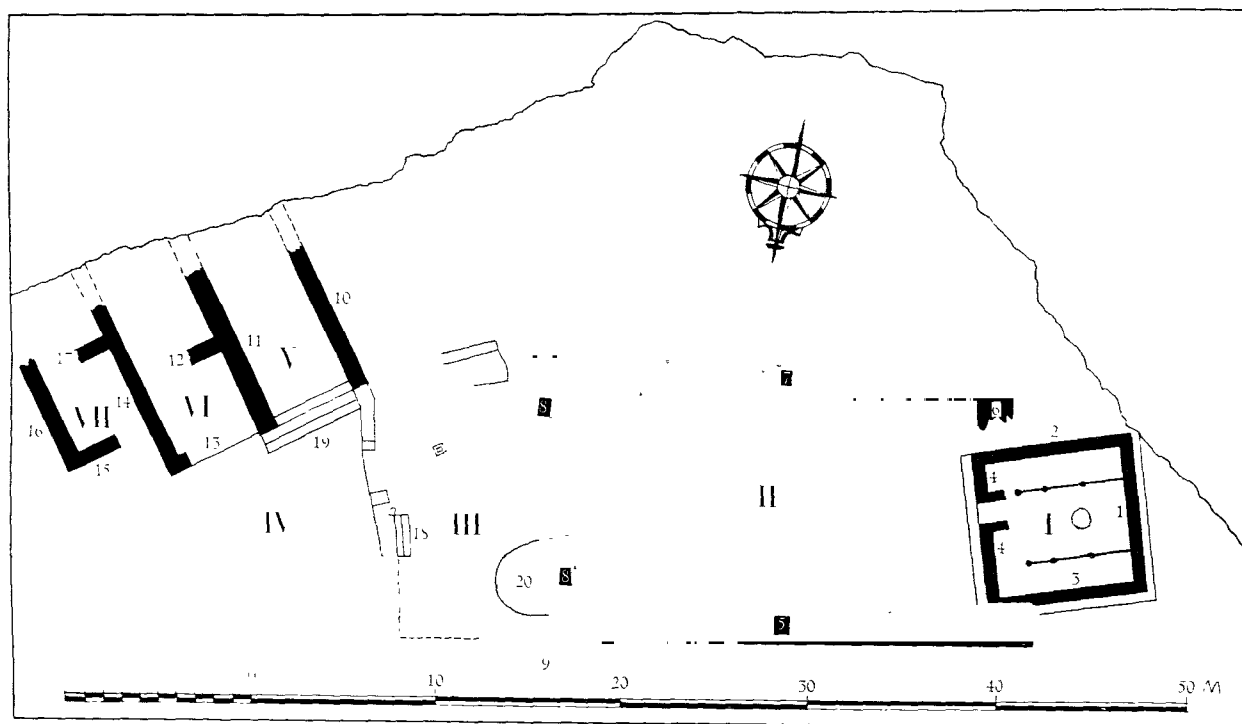

Fig. 47. Vouni. The temple of Athena. Analytical plan and conjectural, reconstructed sketch.

to distinguish at least two different occasions on which the buildings were erected. Walls 1—4 must be contemporary, as they are bonded to each other; and for similar reasons Walls 5—8 must belong to one and the same period. The joint between the two blocks, however, indicate two periods. There can be no doubt that Room I has been added subsequently to the large rectangular room, the W. wall of which (Wall 6) has been destroyed partly in order to make room for the building. The whole situation of the two buildings, and the way they join, makes this clear. Possibly all the remaining structures are of the same period. The offering pit below Wall 7, however, indicates that the buildings are not the earliest traces on the ground. It has been pointed out before that the ash with the minor objects in the pit must have originated at an earlier period, and that the pit may have been arranged in connexion with the erection of the wall. Unfortunately, the poor state of preservation of the remains does not allow a closer determination of the various portions.

If we consider the general plan of the buildings, we note first of all the irregularities and the asymmetrical grouping of them. The entrance into the temenos seems to have been from the N.—W. into the first courtyard, called Room IV. This was of irregular shape. To the S. it was limited by the front of the building containing Rooms V—VII. The eastern and northern boundaries of the court had vanished, and could not be ascertained by means of digging. The building consisting of Rooms V—VII has evidently been oriented along the rampart and not in accordance with the courtyard, Room IV. This may also explain why the same building has quite another orientation than the rest of the structures. From the first courtyard one passes through a gate to a kind of fore-court, Room III, in front of the eastern façade of the large rectangular construction of Room II. Room III is limited in the E. by a fence or screen, the foundations of which are traceable in the rock, and by rectangular ashlar laid out in line with the W. corner of Room V. The N. boundary is constituted by Wall 9, and the western by Wall 8. In the S. the conditions are not so clear. Here Wall 7 is continued to the E. in a kind of foundation sunk down into the rock. The foundation may also have served as a base for sculptures. The arrangement should perhaps be reconstructed as follows: The S.—E. corner of Room II, and the W. corner of Room V were probably connected by means of a fence or screen, or some similar arrangement, which terminated the courtyard, Room III. In how far this court was symmetrical, may be difficult to state on account of the considerable portions which are missing in the walls. The main purpose with the court seems to have been to set up sculptures in the same. There is no visible order in which the sculptures have been placed on the floor, but to judge from the preserved holes for the bases in the rock, most of them stood in the centre of the court, just inside the entrance. A safe reconstruction of the enclosure can nowhere be made. The preserved remains are not sufficient for that purpose, but most likely there has been only a lower fence and no high wall. The court might be a mere passage up to the real fore-court of the temple which is called Room II.

The heavy foundations which mark out this area indicate that the building should be reconstructed in quite another way. Here, too, it must have been a matter of an open courtyard, like the previous ones. But while the floors of those were more or less preserved, no-

thing was left of the floor of Room II. It has already been suggested that Wall 5 should be the wall enclosing a large terrace the floor of which has disappeared, as it was situated on a comparatively high level, in any case above the present surface of the field. The nature of this courtyard cannot be determined with any certainty. It has already been put forward that the floor was sloping and rather irregular. Most likely the courtyard was used, like the court, Room III, for sculptures and altars, though no traces of the same are preserved. Though no traces of the walls which enclosed the terrace area, could have been preserved, it must be assumed that such walls existed around the upper edge of the terrace. The height of the walls cannot be determined.

The question may be raised as to what was originally the central or chief portion of the terrace court, before the temple, Room I, existed. This can only be answered by mere surmises in that no architectural remains are preserved which might settle the question definitely. There might, of course, have been some large altar placed directly on the terrace, but the subsequently added, closed temple may indicate that there was some recess or similar structure at the rear of the courtyard. In the temple, Room 123, (p. 189) N. of the palace, there was a similar arrangement in the first period. The recess was subsequently rebuilt. However, no traces of such a recess in Wall 6 are preserved. It is, however, hardly to be expected that anything should have been preserved outside Room I. The floor of the room was removed only over a comparatively small area, and there may still be remains of a recess below the floor.

The position of the temple, Room I, is surprising. It has been placed at the side of the main axis of the rectangular court and, furthermore, the axes of the two structures diverge. The arrangement is best explained by the vicinity of the rock-edge W. of the temple. As has been shown above, the rectangular building must have been erected first. When Room I was constructed, the Wall 6 was pierced and the sanctuary placed partly where this wall had once stood and not in line with it, which would have been natural. It seems difficult to adduce any other explanation of this matter than lack of space. The whole temple is situated very near the edge of the rock which is here distinctly marked by the perpendicular side of the mountain. As can be seen on the plan, the S.—W. corner of the sanctuary just touches this edge. Granted that the building should have the present size, there is actually no other way of placing it than somewhat removed to the north of the axis of the terrace-court, or superimposing this. The present effect was achieved by these local conditions. Axiality and symmetry were thus lost, but the architect apparently tried to obtain a certain degree of axiality by placing the entrance as near the central axis as possible. This explains its present peculiar position as not being in the middle of the wall, but to the S., though the building is otherwise symmetrical. A similar endeavour to place entrances and altars on the same axis will be demonstrated as regards the temples of Soli (cf. p. 487).

From the aforesaid we may make the following conjectural reconstruction of the buildings on the site. The area which has been called Room II was a large courtyard situated on a terrace enclosed by heavy walls. Possibly no building was connected with this courtyard though there might have been a small recess in the W. At any rate the building, called

Room I was added subsequently in the way described above. This must have had a tiled roof. As to the nature of the roof, it is, of course, not possible to state anything with any certainty. As the roof was tiled it seems most likely that it was saddle-shaped and the reconstruction with a flat, or almost flat roof is less likely. The antefixes found among the debris were the ends of the tiles. The interior of this building was divided into three parts by means of wooden, parallel partition walls so that the middle portion is somewhat wider. As the whole building has a perfectly square plan the three interior rooms, and especially the side-rooms, are rather narrow. There is only one entrance into the building, and one had to pass from the middle room into the side-rooms. The large rectangular terrace-court in front of the sanctuary had a floor sloping towards the entrance in the E., opposite the building. The courtyard, called Room III, may be considered as a mere throughfare to reach the terrace. It is symptomatic that the votive sculptures were evidently concentrated at this part. In the sanctuary, mentioned above, to the N. of the palace, the sculptures were concentrated at a corresponding part of the building, e. g. grouped around the entrance into the rectangular, large courtyard in front of the sanctuary proper. The nature and complete shape of the first courtyard (Room IV) cannot be determined as two sides of it were entirely destroyed.

The building on the S.—E. side of it, containing Rooms V—VII, deserves some explanation. The structure was provided with flat roofs, possibly connected with each other at the same level. The rear of the building was most likely joined with the rampart wall, at present fallen down with the whole rock edge on this side. The many finds made in connexion with the excavation of these rooms indicate that the structure served as a treasury, in which votive offerings were stored. There seems to be no other explanation of this house than the one mentioned. We thus meet with a rather interesting type of sanctuary which, though much damaged by weather and wind, shows features characteristic of previous Cypriote periods, as well as of Greek temple sites. The square sanctuary at the rear of several courtyards behind each other may for the time being be taken as a plan characteristic of Cyprus, while its combination with treasuries may indicate Greek influence. Unfortunately most of the votive offerings had disappeared like the votive sculptures which had once been placed on the bases in the middle courtyard, but few pieces left showed that a similar mixture as in the architecture should have been possible to demonstrate also as regards the votive offerings.

FINDS

OBJECT REGISTER

1—148. See The Palace.

149. Fragments of a bronze bowl with rather wide rim.
Surface find.

150. Bronze relief representing a bull attacked by two lions.
The bull is seen in right profile, bent down with r. foreleg and l. hind leg bent underneath the body; the

l. foreleg and r. hind leg are outstretched; the head is turned towards the spectator and seen nearly full face. The legs have marked hoofs and muscles; the muscles are marked on body, and the loose skin on brisket is rendered; sculptured mouth, nostrils and eyes with eyelids; outstanding ears; ends of horns missing.

- The bull is attacked by two lions on his back; the r. one with the body in right profile, the l., in l. profile, the lions thus facing each other; the hind legs of the l. lion are placed on the outstretched r. hind leg of the bull; its r. foreleg grasps the side of the bull; its head is lowered, its jaws are sunk in the bull's back; his tail hangs down with the end turned upwards. Details of paws, claws, and muscles of body are well marked; the mane falls backwards over the curved neck; the head is turned *en face* with erect ears; eyes with lids and incised iris; thick whisker-hair; and a deep wrinkle between the eyes gives the lion a fierce expression. The r. lion is sitting with its hind legs placed on bull's neck; in shape and other details like the l. one. The relief is made of thick bronze; the back of the relief is flat but for concave surfaces which correspond to the bodies of the three animals. The tip of tail of r. lion missing. Length 19.5. Height 8.5. Length of l. lion (tail included) 11.0. Length of r. lion (end of tail missing) 9.2. Length of bull (leg to leg) 14.2. Length of bull's body (r. ear included) 10.8. Room I. Floor.
151. A replica of the bronze relief No. 150, but it is not cast in the same mould. There are some small differences to be distinguished. the head of the bull is a little more uplifted, the gap between the bull's r. foreleg and its l. hind leg is larger, etc. Ends of horns missing. Length 22.5. Height 9.0. Length of l. lion (tail included) 11.5. Length of r. lion (tail included) 10.5. Length of bull (leg to leg) 15.5. Length of bull's body (ear included) 11.5. Room I. Floor.
152. Statuette of solid bronze representing a cow walking forwards with r. foreleg and hind leg well advanced; a ring of incised lines above the hoofs representing hair, well modelled legs, udder, and body; thick neck with brisket, the loose skin on neck well rendered; the head is slightly turned to the left; modelled muzzle with mouth and nostrils; eyes in relief with marked eyelids, r. ear cocked forward; l. ear backwards; curved horns; only short part of tail preserved. The l. hoof of foreleg and the r. of hind leg is provided with a central peg for fixing the statuette to a base. The representation is very realistic. Length 25.0. Height (pegs included) 20.0. Thickness over belly 7.0. Width of neck 6.3. Length of head 6.3. Room I. Floor.
153. a) Terracotta antefix in shape of a palmette growing up from the centre of a double volute; a rhombic field in centre, rough back. L. lower part and top missing. Length 17.5. Width 14.0. Thickness 4.0.
 b) R. side of a terracotta antefix, as No. 153 a.
 c) The central part of a terracotta antefix, as No. 153 a. These fragments seem to have been cast in the same mould as No. 153 a. Room I. Floor.
154. Three edged arrow-head of bronze with concave sides, midrib, short, tubular socket with rivet-hole. Length 3.5. N. of Wall 3.
155. Handle of bronze belonging to a bowl or large ladle; flat, narrowing towards the top which ends with a goose's head; fixed to the bowl with a curved triangular mounting, in one piece with the handle, and pierced by seven rivets along the edges; a solid bronze loop attached to handle. Slightly deformed. Length 25.0. Width of handle at base 3.0. Width of handle at top 0.8. Length of goose's head 3.5. Length of mounting 6.4. Diam. of loop 3.0. N. of Wall 3.
156. Fragment of a large bronze sheet, rather thick, with one side straight with flat edge, bent up; pierced by two holes placed the one under the other, near edge. Length 27.0. Thickness of edge 0.6. N. of Wall 3.
157. R. hand with fingers closed around an object which was inserted through a bored hole through hand; bracelet around wrist. White limestone. Length 4.8. On Wall 3.
158. a) Long, rectangular bronze mounting with one rounded end; the other straight; pierced by five square holes for rivets. The mounting is folded together. Length 32.0. Width 2.5.
 b) Five bronze nails with large flat heads; square, transverse section, probably belonging to No. 158 a. Length 3.2.—2.5.
 c) Eight bronze nails of various size; square section and large, flattened heads; one of which has the pointed end bent into a loop, two of which are angularly bent, and three of which with missing heads. Length 12.0—3.7.
 d) Chisel of bronze; splaying edge; curved. Length 13.5.
 e) Fragment of a spear-head; square in section; hollow. Only pointed end preserved. Length 6.6.
 f) Fragment of a rod of bronze, square in section. Some irregular cuttings at one end. Length 9.4.
 g) Small fragments of bronze sheet decorated with embossed dots surrounded by wavy lines; fragments of two small hinges, one of which is pierced by a rivet.
 h) Large pieces of lead, probably used as a weight in a base for some object. Length 8.0; 9.0. N. of Wall 5.
159. Two arrows of bronze, fixed together with a piece of lead; a votive gift.
 a) Long, solid arrow with head as No. 184 a; moulded end with concave top for the bow-string; the feathers are rounded forwards and end in acute angles and inserted in a slit, decorated with parallel incised lines. Length 48.6.
 b) As No. 159 a, but feathers missing. Length 49.3. N. of Wall 9.
160. Cylinder of black steatite pierced by a hole through the longitudinal axis. The representation consists of two men walking to the r. with feet in profile; heads marked as dots; helmets on head; the first one with arms along the sides of body holding some object in l. hand which might be a bow; the second with l. arm uplifted; wearing long gowns, horizontally hatched; in front of them lies a deer in l. profile with head turned backwards showing the r. profile; large eye marked with

- a dot; outstanding r. ear; long curved horns; above deer's back, a sitting bird in l. profile with pointed beak and large eye marked by a dot; in the space between bird and first human figure, a *bucranium*. Length 2.2. Below Wall 9.
161. Fragment of a large bronze sheet broken off in a roughly semicircular shape. The edges bent up. Length 26.5. Width 13.0. N. of Wall 9.
162. Bronze rod with twisted and hooked ends, square in section. Deformed. Length 6.9. N. of Wall 9.
163. Pike of bronze with circular section, tapering towards the pointed end; tubular socket with moulded ridge between socket and pike. Length 17.5. N. of Wall 9.
164. Fragments of a marble bowl with square outside; the bowl is shallow and sunken down in a square piece of marble with slightly moulded straight sides. On upper, flat side runs an inscription in Cypriote characters (See Appendix IV). The bowl is partly restored in gypsum. Square 24.5. E. of Wall 7.
165. Fragment of bronze arrow-head. Room IV. Floor.
166. Bronze nails, as No. 158 c. Below Wall 9.
167. Large spear-head of iron, split up into four portions; tubular socket pierced by rivets of which two are preserved; the socket ends with a ring-shaped, flat mounting of bronze; at the joint between spear-head and socket, a moulded ring-shaped bronze mounting is placed. Length 41.0. Diam. of moulded bronze mounting 3.8. Room VI.
168. Spear-head of iron with leaf-shaped blade; midrib; pointed end; tapered socket ending with a flat, ring-shaped mounting of bronze. Large piece of well preserved wood in socket. Length 33.2. Length of wood 8.8. Room VI.
169. Iron dagger, narrow lancet-shaped with low midrib; cross-bar, and flat hilt. Fragments of bone found close by, probably the iron hilt was inserted in a bone handle. One side of cross-bar, and most of hilt missing. Length 39.0. Room VI.
170. Pike-shaped spear-head of bronze with square transverse section; tapered socket, circular in section; moulded ridge between spear-head and socket, and small moulding placed higher up on socket. Pointed end of spear-head, and end of socket missing. Length 22.0. Room VI.
171. Leaf-shaped spear-head of bronze; hollow; two edges; pointed end; short; slightly tapered socket pierced by two rivet-holes; socket with circular section. Length 16.2. Room VI.
172. Pike or spear-head of bronze with solid head, square in section; tapered outline; pointed end; the socket is formed by folding the bronze around the shaft; socket pierced by rivet-hole. Length 10.6. Room VI.
173. Fragment of a bronze sheet broken off in a roughly square shape with three rounded corners; edges slightly bent; pierced by a rivet-hole. Length 14.0. Room VI.
174. a) Seven arrow-heads of bronze, as No. 154, but with prolonged socket. Length 4.6—3.7.
- b) Four arrow-heads of bronze, as No. 174 a, but the pointed end with straight sides, and triangular in section; socket without pierced hole. Length 4.6—4.4.
- c) Two short, three-edged arrow-heads of bronze with straight sides; pointed end; short, tubular socket. Length 2.8; 2.7. Room VI.
175. a) Eight bronze nails with thick head; square section, and bent at right angles. Length 6.0.—4.0.
- b) Four circular bronze mountings with convex outside; remains of some material at centre on the concave side for fixing it to the nail; three of them incomplete. Diam. 1.6.
- c) Bronze rivet with square section. Length 2.3.
- d) Staple of bronze with hooked ends. Length 2.5.
- e) Rather thick, circular ring of bronze. Diam. 3.8.
- f) Bronze nail bent to an irregular ring. Diam. 1.9. Room VI.
176. Thin bronze rod, square in section, hooked at one end which is flattened; opposite end slightly pinched; probably the handle of a ladle. Length 38.8. Room VI.
177. Various fragments of iron, among which can be distinguished
- a) Two nails with large, flat heads; pointed ends missing. Length 8.5; 8.2.
- b) Large nail with square section; widening head; pointed end missing. Length 11.3.
- c) Leaf-shaped arrow-head with midrib; pointed end; narrow tang (missing). Length 7.5. Room VI.
178. a) Four-sided arrow-head of bronze; double-curved sides; rapidly tapering outline, rhombic in section; narrow, solid tang.
- b) Plain finger-ring of bronze. Diam. 2.5.
- c) Socket of bronze belonging to a spear-head; moulded base; end missing. Length 4.5.
- d) Two bronze nails, one with large, flat head; broken; the other with small, thick head. Length 8.2. Room V. Floor.
179. Flat, circular spindle-whorl of terracotta, pierced by a hole through the centre. Diam. 6.0. Room V. Floor.
180. Coarse shallow bowl with flat base; straight sides; widening upwards; plain rim; two projections below rim. Diam. 27.0. Stair 19.
181. a) Bronze pin with circular section slightly widening towards the upper plain, flat end; pointed end missing. Length 16.8.
- b) Bronze pin or instrument with plain, flat top; upper part square in section; narrowing towards the pointed end; lower part of pin circular in section; point missing; broken. Length 19.5.
- c) Six bronze nails with large mushroom heads; square in section; pointed ends. One of them has the point bent to a coiled loop; one fragmentary. Length 21.2—3.7. Room V.
182. a) Segment-shaped mounting of bronze; slightly convex, pierced by a rivet in the middle; one rivet-hole at the edge. Length 3.6.

- b) Fragment of bronze mounting of irregular shape, pierced. Length 3.9.
- c) Staple of bronze with hooked ends. Length 2.7.
- d) Cylinder of bronze leaf retaining small slit along side; slightly upturned edges. Length 2.9. Stair 19.
183. Fragments of a bronze bowl with upright rim, slightly splayed. W. of Wall 10.
184. a) Six three-edged arrow-heads of bronze with edges elongated into barbs; short, tubular socket; two of them with pierced socket. Length 2.8.—2.4.
- b) Two staples of bronze, as No. 182 c. Parts of ends missing. Length 2.7; 2.2. W. of Wall 10.
185. a) Iron knife with broad blade and pointed end; one cutting-edge; thick back; flat tang with a rounded excrescence near the blade, pierced by rivets. Broken in two pieces; incomplete. Length 13.5; 14.5.
- b) Fragment of iron sheet with two straight sides forming an obtuse angle, pierced by a rivet in the corner; fragments of a corroded bronze rivet at one side; the sheet is bent, giving the fragment a gently convex outside. The fragment might belong to a helmet or cuirass. W. of Wall 10
186. Fragments of an iron knife with one edge and flat tang. Length of fragments 7.8; 5.3. Room II. E. corner.
187. a) Fragments of a large bronze bowl. Only pieces of the deformed rim preserved, which was decorated with an incised line. On one piece of rim, a folded bronze sheet pierced by four rivets, probably a repair in ancient times. Length 17.0; 11.5.
- b) Bracelet of bronze with flattened, round ends. Deformed, one end missing. Diam. 5.5.
- c) Circular, convex bronze mounting with the edge folded upwards; pierced by a central hole. Incomplete. Diam. 3.3
- d) Upper part of the handle belonging to a ladle of bronze with square, transverse section; top of handle bent in a hook and ending in a goose's head. Length 9.8.
- e) Bronze nail with mushroom head; bent. Length 6.7. Room II. E. corner.
188. Three arrow-heads of bronze, as No. 174 c. Length 3.4, 3.5, 4.0. Room II. E. corner.
189. Circular, flat disc of terracotta, one side with smooth surface, the other with unworked surface; pierced by a hole at centre; probably the wheel to a chariot statuette. Diam. 6.6. Room II. E. corner
190. Fragment of bronze sheet. Length 5.8. Wall 8. Entrance.
191. Spiral twisted bronze rod, square in section; tapering into a pointed end; opposite end missing. Length 10.4. Wall 8. Entrance
192. Bronze tool with tapering socket with moulded end; from socket starts a rod, with octagonal section; top bent at right angle calling of a modern hammer. This cross-bar has flattened ends, and rounded excrescences at the upper side at either end with concave tops; at the joint between socket and tool, there is a moulded mounting. Length 17.0. Diam. of socket 1.7. Wall 8. Entrance
193. Spear-head of bronze, as No. 170, but socket broken in ancient times; the head re-used by fixing to the spear with a rivet. Length 18.0. Wall 8. Entrance.
194. a) Six bronze nails with square section, and large button-shaped heads. Hooked and deformed. Length 16.7—7.5.
- b) Bronze loop with the ends pinched together; loop circular in section; legs square in section; ends of legs missing. Length 7.4.
- c) Bronze pin with pointed end; head missing. Deformed. Length 12.0. Wall 8. Entrance.
195. Iron nail with square section and hammered, bent head. Head and two points belonging to three other nails. Length 9.3. Wall 8. Entrance.
196. Fragment of the wide, flat rim belonging to a bowl of greenish steatite. Length 5.8. Wall 8. Entrance.
197. Lump of lead. Length 4.0. Room II. N. corner.
198. a) Two spear-heads of bronze, as No. 193, but without pierced rivet-hole. Length 11.8; 11.2.
- b) Circular bronze disc with moulded edge, pierced by four rivet-holes near the edge. Diam. 4.8. Room II. N. corner.
199. Arrow-head of bronze, four-sided with straight sides; pointed end; square section; long, solid tang. Length 13.8. Room II. N. corner.
200. Two arrow-heads of bronze, as No. 154. Length 3.4; 3.2. Stray find.
201. Antefix of terracotta, as No. 153, but better preserved. Length 24.5. Width 14.0. Stray find.
202. a) Arrow-head of bronze, as No. 178 a, but with concave sides. Pointed end defaced. Length 8.5.
- b) Fish-hook of bronze similar to modern fish-hook; sharp point and small barb. Length 2.2. Room II.
203. Lower part of an Athena statuette of limestone. Iso-linear feet standing on base; r. hand holding an object; l. arm along side of body, its hand holding circular shield with marked edge, which rests on the ground in front of the statuette. Upper part, from breast, part of r. foot missing; base chipped. Worn. White limestone. Height 25.0. Between Altar 20 and Wall 9.
204. a) Arrow-head of bronze, leaf-shaped with slightly double-curved outline; four-sided; rhombic section, and narrow, solid tang. Small part of tang preserved. Length 4.5.
- b) Handle of bronze, probably belonging to a ladle; square in section; top of handle bent to a hook ending in a flattened tip; lower end of handle forked with three prongs, the middle one bent up, for fastening the handle to the ladle. Length 21.0.
- c) Fragment of a large bronze nail with circular section; large, flat head. Length 3.5.
- d) Fragment of a bronze loop. Length 3.1.
- e) Fragments of bronze sheets, one with a rounded excrescence at one side, pierced by a hole. Length 5.3; 8.3.
- f) Silver strip forming a narrow row of contiguous ellipses, probably used as some mounting. Length 11.0; 4.7. Between Altar 20 and Wall 9.

205. a) Leaf-shaped arrow-head of bronze with midrib; short, solid tang, square in section, with small cuttings at the sides. Length 6.4.
 b) Arrow-head of bronze, as No. 154. Length 3.6.
 c) Arrow-head of bronze, as No. 205 b. Length 3.6.
 d) Various fragments of bronze sheet, defaced, some of them decorated with a string of beads and ridges in *repoussé*. Length 9.2; 8.5; 8.9.
 e) Two bronze mountings consisting of circular plaques pierced by a staple; defaced. The staple of one mounting is missing. Diam. of plaque 2.6; 2.9. Length of staple 4.5.
 f) Three bronze nails with square sections; one with large, button-shaped head, and lower end missing; heads of the two other missing. Length 7.0; 8.0; 10.4. Outside Wall 7.
206. Torso of female statuette of terracotta, similar to No. 243 a. Much worn. Height 8.4. Outside Wall 7.
207. Torso of female statuette, as No. 491. Broken at waist. White limestone. Height 7.5. Room II. Near Wall 5.
208. a) Arrow-head of bronze, as No. 154. Length 2.4.
 b) Straight bronze pin with slightly thickening head; point missing. Length 10.8.
 c) Fragments of plain bronze sheet.
 d) Small bowl-shaped mounting of bronze, possibly the central boss in the bottom of a bowl, or on a shield. Diam. 4.5. Room II. Near Wall 5.
209. Fragments of a terracotta antefix, as No. 153. Near Wall 5.
210. Head of Athena with Corinthian helmet; on top of helmet small fragments of a sphinx are visible; oval, narrow face with finely rounded chin; high cheeks; long, slightly bent nose (tip of nose missing); lancet-shaped eyes with double eyelids; marked eyebrows; smiling lips; three almost vertical wrinkles at the beginning of the nose give the face a grim expression; under the helmet, the hair falls over the forehead in spiral curls parted in the middle; the ears are covered by the curls, only the circular pendants of earrings visible; necklace with small pendant visible at front of neck. Broken obliquely from helmet at back of head to just below pendant of necklace. White limestone. Height 10.5. Room II. N. W. corner.
211. Fragment of the shoulders belonging to an Athena statuette; traces of necklace; the snake-heads of the aegis are visible at l. side. Height 5.0. Room II. N. W. corner.
212. Fragments of an Athena statuette, most of which is indistinguishable. The largest fragment represents a breast with part of neck; the border of the aegis is visible on back of shoulders. White, very soft limestone. Height of fragment 16.5. Room II. N. W. corner.
213. Fragment of upper part of statuette with hair hanging down on l. shoulder. No details visible; much worn. White, very soft limestone. Height 14.0. Room II. N. W. corner.
214. a) Fragment of a bronze mounting, probably circular in shape, decorated with lotus flowers in perforated and enchased work. Only part of a lotus flower and part of edge preserved. Length 3.6.
 b) Circular bronze mounting consisting of a circular, slightly convex plaque pierced by a staple with hooked ends. Diam. of plaque 3.3.
 c) Bronze nail with square section and large button-shaped head. Pointed end missing. Length 10.0. Room II. N. W. corner.
215. Fragment of a head (probably Athena). Only the circular rosettes in the ears clearly visible; part of helmet(?) preserved. White limestone. Worn. Height 7.0. Room II. Centre.
216. Head of Athena, similar to No. 210, but much worn; nose missing. White limestone. Height 8.0. Room II. Near Wall 4.
217. Silver obol. *Obverse*: bull standing l.; above, winged solar disc; border of dots. *Reverse*: eagle (?) standing l.; to the l., inscription: *pu ba*. To the r., olivespray with two leaves and one berry; the whole in incuse square. Diam. 1.1. Weight 0.75. E. of Wall 16.
218. Silver obol, as No. 217. Diam. 1.1. Weight 0.75. Room II. Centre.
219. a) Arrow-head of bronze, as No. 199. Tang missing. Length 5.5.
 b) Fragment of the rim belonging to a bronze bowl. The rim is flat and slightly splaying. Length 7.5.
 c) Fragments of bronze mountings, probably belonging to a shield. Room II. N. E. corner.
220. a) Arrow-head of bronze, as No. 154. Length 3.5.
 b) Arrow-head of bronze, leaf-shaped; tapering towards the pointed end, with high midrib; solid tang. Thick, clumsy, and asymmetrical. Length 6.3.
 c) Leaf-shaped arrow-head of bronze with midrib; triangular piece cut out at either side of the tubular socket, the edges thus forming pointed barbs; pierced socket. Length 4.5.
 d) Rivet of bronze with flattened head; square in section; pointed end. Length 2.0.
 e) Two pieces of silver strip, as No. 204 f; one fragment smaller. Length 1.5; 1.6. E. of Wall 16.
221. a) Circular, plain bronze disc with slightly upturned edge. Diam. 6.9.
 b) Bronze sheet; probably the rim of a bowl; much defaced. Length 15.5.
 c) Roughly rectangular bronze sheet with one long side slightly curved; the other roughly parallel; both short ends oblique. The bronze sheet might possibly be a cheek-piece of a helmet. Length 9.5.
 d) Bronze mounting consisting of circular plaque pierced by two square holes. Diam. 2.7.
 e) Rectangular sheet of bronze with straight short ends. Length 3.6. E. of Wall 16.
222. Bronze strigil with slightly curved blade, semicircular in section, but defaced with flat, rather wide handle. End of blade and the loop-handle missing. Length 17.5. E. of Wall 16.

223. Fragment with base of l. foot of terracotta, once wearing sandal; traces of folded chiton visible. Yellow clay. Height 7.0. E. of Wall 16.
224. Head of Athena with Corinthian helmet; oval face; strong, rounded chin; thick, slightly smiling lips; nose in line with forehead; large eyes of myrtle-leaf shape; the front hair rendered by curved grooves; the helmet had probably a crest. Broken off just below chin; parts of helmet missing. Worn. White limestone. Height 7.6. Room II. W. part
225. Fragment of head of terracotta put together from many pieces; oval face; small eyes of myrtle-leaf shape; marked lids; the hair lies over forehead in a wavy strip from ear to ear. Top and back of head behind the ears, part below r. eye, nose, and l. cheek missing; chin chipped. Red clay. Height 15.5. Room II.
- 226 See The Palace.
227. Fragments of thin bronze mounting, with circular outline, decorated by ridges and dots in relief. Some of the fragments are pierced. Probably part of the peripheric bands of a shield. Length 6.0. Pit below Wall 7
- 228 a) Several fragments of silver strips, as No. 204 f, in larger and minor scales, among which one is considerably thicker and slightly curved. Length 12.5.
b) Flat needle of silver with pointed end; head pierced by an eyelet. Bent. Length 8.0.
c) Fragment of a roughly circular disc of silver sheet; parts missing. Diam. 4.5. Among the fragments are some pieces with rounded corners; each corner pierced by a small hole. Pit below Wall 7.
229. a) Five strips of gold, as No. 204 f, but in various sizes.
b) Rectangular plaque of gold with rounded corners, pierced by a hole at one long side. A representation in relief of a bull walking to the l., with curved horns; hanging tail; muscles well marked. Length 2.0. Pit below Wall 7
230. White Painted (V) sherd, belonging to a large vessel. Length 8.5. Pit below Wall 7.
231. a) Circular bronze disc with slightly bent edge; parts of rim missing; broken. Diam. 7.8.
b) Fragments of bronze sheet, among which two larger pieces. On one of them, a representation of a closed hand in high relief, holding a coiled serpent. This forms a loop, but is not complete on the preserved sheet. On the other fragment, remains of a wing, with two rows of feathers partly preserved. Length 9.2. 8.0.
c) Arrow-head of bronze, four-sided, rhombic in section, straight sides, pointed end; solid tang, bent. Length 7.5
d) Three bronze nails with flat heads, square section; one bent and head missing. Length 6.7; 5.7; 3.5. S. of Wall 7
- 232 a) Fragment of a bronze bowl with plain rim. Length 24.0
b) Fragment of a large bronze sheet with thick, flat edge. The sheet is strong and thick along the edge, but rather thin along the broken side. Length 23.0.
c) Fragment of a bronze sheet with thick, flat edge, decorated by a narrow border of four incised lines near edge. Length 22.0. S. of Wall 7.
233. Statuette of terracotta representing a man lying on a square couch. The man faces the spectator resting the upper part of body on l. arm, which is hidden beneath the himation; r. arm rests on his r. knee which is uplifted. He wears chiton and himation. Head and neck missing; much worn. Height 7.0. Length 11.5. S. of Wall 7.
234. Fragment of a lion statuette, standing on rectangular base with forelegs outstretched. Only the middle part of statuette and paw of l. hind leg are preserved. White limestone. Length 11.0. Height 8.3. S. of Wall 7.
235. a) Fragment of bronze nail with button-shaped head. Length 4.3.
b) The point of a bronze spear-head with square section; partly hollow. Length 4.2.
c) Two fragments of bronze sheet, one rectangular, slightly widening at one rounded end, which is pierced by three rivet-holes in a row at the middle, two of which are pierced closed together; the other is an irregular square in shape with two corners pierced by rivet-holes. Length 5.0; 3.6.
d) Three fragments of bronze sheet, defaced. Length 4.7; 11.4.
e) Narrow bronze pin with one pointed end; the other Y-shaped. Length 3.9. S. of Wall 7.
236. Fragment of an animal with slender body; marked ribs; hanging tail; slightly bent hind legs. Base, forelegs, neck, and head missing. White limestone. Length 8.5. S. of Wall 7.
237. Two arrow-heads of bronze, as No. 154. Length 4.1; 3.1. S. of Wall 7.
238. Many fragments of silver strip, as No. 204 f, but in larger and smaller sizes. Pit below Wall 7.
239. Gold needle, square in section; pointed end; pierced by an eyelet through head. Length 15.4. Pit below Wall 7.
240. Hollow, bell-shaped pendant of gold, hanging in a narrow gold string, Length 2.3. Pit below Wall 7.
241. a) Fragment of a bronze nail, square in section; head missing. Hooked. Length 5.0.
b) Bronze staple, defaced. Length 5.5. Pit below Wall 7.
242. Bronze arrow-head; fragment. S. of Wall 7.
243. a) Moulded terracotta statuette with flat back representing a woman standing with both arms along sides of body; slightly marked breast; traces of hair hanging down over shoulders on either side. Head missing. Red clay. Height 13.0.
b) Fragment of female terracotta statuette with flat back, r. arm bent over breast, the hand placed between the breasts; l. arm slightly bent along side of body, the hand holding folds of dress; double necklaces

- hanging down over breast; traces of himation visible which resembles that of No. 510. Lower part, neck, and head missing. Worn; red clay. Height 8.8.
- c) Fragment of terracotta statuette, as No. 243 b. Red clay; worn. Height 5.7. N. of Wall 5.
244. a) Bronze spear-head, four-sided with tubular socket, most part of socket missing. Length 7.7.
b) Fragment of terracotta horse with four short, peg legs; straight neck; head with marked eyebrows; ears, r. foreleg, and back part missing. Height 9.0. Stray finds.
- 245—253. See The Palace.
254. Circular mounting of bronze with a central, convex boss. Fragmentary. Diam. 8.0. Room I. Below floor.
255. Button, as No. 413 b, of greenish steatite. Diam. 1.4. Room I. Below floor.
- 256—262. See The Palace.
263. Head of Athena with Corinthian helmet; oval face; faint smile on the slightly protruding lips; full cheeks; nose in line with forehead; eyes of myrtle-leaf shape; two rows of curls over forehead beneath helmet, the curls rendered by parallel notchings; circular rosettes in the ears; chin and nose chipped; crest and part of helmet missing. White, soft limestone. Height 5.5. Room II. W. part.
264. Horse's head of terracotta with long, narrow nose; slightly marked nostrils; rather bulging eyes; erect ears; mane visible between ears in an elevated mass decorated by parallel grooves. Red clay. Height 6.5. Stray find.
- 265—307. See The Palace.
308. a) Circular bronze mounting; the one side concave and the other convex; pierced from the concave side by a staple with ends bent up over the edge. Diam. 3.3.
b) Staple of bronze with legs pinched together. Length 2.6. Stray find.
- 309—387. See The Palace.
388. Silver coin. *Obverse*: Male head, facing r., Archaic expression. *Reverse*: Oblong incuse with irregular ground. Diam. 1.4. Weight 1.55.
- 389—412. See The Palace.
413. a) Arrow-head of bronze, as No. 174 a, Length 3.6.
b) Two buttons, one of greenish steatite, the other of bright-blue stone (lapis lazuli?), with one side flat, the other slightly convex, pierced by four holes. Diam. 1.5. Stray find.
- 414—584. See The Palace.

CLASSIFICATION OF FINDS

Pottery.

In comparison with the strata in the palace this temple-site produced only few potsherds. Only one complete vase was found (No. 180), a coarse bowl of common shape. As to the sherds, only one (No. 230) could be determined as belonging to the Cypro-Archaic II period. (This was found on the bottom stratum in the pit below Wall 7). The majority of the rest belonged to the Cypro-Classic periods. Among the local Cypriote ware there are a few imported sherds, some of them Red Figured.

Limestone sculptures (Pls. XL, XLI).

1. Most of the limestone sculptures can be identified as representing Athena (Nos. 203, 210, 211 212, 215, 216, 224, 263). 2. The rest of the fragments are attributed to various types of minor plastic (Nos. 157, 207, 213, 234, 236).

As to the Athena sculptures they may be classified in accordance with the styles established for the palace sculptures. None of the fragments can be ascribed to a style previous to III A. No. 210 represents this style and so do Nos. 224 and 263 though they are of smaller size. The rest are too fragmentary to be ascribed with certainty to any style.

Terracotta sculptures (Pl. XLI).

All the terracotta sculptures are of minor size and made in common moulds. 1. There are specimens of female terracotta statuettes with isolinear feet (Nos. 206, 243 a, b, c).

2. Another type represents a recumbent figure (No. 233). 3. No. 225 is of somewhat larger size and represents a moulded type common in Mersinaki. The foot (No. 223) is a mere fragment. Statuettes of horses are represented by Nos. 244 b, 264. No. 189 is a wheel of a terracotta chariot.

Bronze sculptures (Pls. XLII—XLIV).

The bronze sculptures are of two types. 1. A relief representing a bull attacked by two lions (Nos. 150, 151) and 2. the cow statuette (No. 152).

Iron.

Spear-head (Pl. XLIV).

Two types are represented, both with sockets: 1. Leaf-shaped with midrib (No. 168). 2. Head split up into four portions (No. 167). This was probably for sacred use or a mere votive offering.

Arrow-head (Pl. XLIV).

There is only one type, viz., leaf-shaped with midrib and tang (No. 177 c).

Dagger.

The dagger has a narrow, lancet-shaped blade with low midrib, chape, and flat hilt (No. 169).

Knife (Pl. XLIV).

Both knives represented are of a similar type, with one cutting edge and thick back (Nos. 185 a, 186).

Nail.

The nails show slight varieties of the same type, with square section and large, flat head (Nos. 177 a, b, 195).

Sheet.

The sheet (No. 185 b) might have been a part of a shield.

Lead.

Among the two pieces of lead only one (No. 158 h) has a shape which can be determined. Most likely it was a weight inside the foot of some bronze object or vase. The other (No. 197) is a mere lump.

Bronze.

Spear-head (Pl. XLV).

The spear-heads represent generally two types. 1. Socket right through; two leaf-shaped edges, the whole being lancet-shaped (No. 171) 2. Socket right through; straight, tapering point with square section (Nos. 170, 178 c, 193, 198 a, 235 b, 244 a). Besides these more or less complete spear-heads there is a fragment which cannot be classified (No. 158 e).

Votive arrows (Pl. XLV).

The solid arrows, No. 159, fixed together with a piece of lead, cannot have served any practical purpose, and should, therefore, be regarded as a votive offering. The arrow-heads are of Type 5 (cf. below).

Arrow-head (Pl. XLV).

A great many varieties are represented which can be divided into generally two classes in accordance with the principle for the method of fixing them to the arrow. The first group represents the tang-construction, the second the socket-construction. Within both groups various types are recognizable.

Type 1. Leaf-shaped with midrib and solid tang with square section (Nos. 205 a, 220 b).

Type 2. Four-sided, rhombic section, solid tang; a) straight sides (Nos. 199, 219 a); similar but with double-curved sides (Nos. 178 a, 202 a, 204 a, 231 c).

Type 3. Three leaf-shaped edges with socket. There are some varieties: a) the edges extend over the whole arrow in which there is a hole for the shaft (Nos. 154, 188, 200, 205 b, c, 208 a, 220 a, 237); b) the socket projects from below the edges; no rivet-hole (Nos. 174 a, 413 a); c) the very point with straight, triangular section (No. 174 b).

Type 4. Short type with triangular section (No. 174 c).

Type 5. Triangular type with leaf-shaped edges, ending in barbs (Nos. 184 a, cf. No. 159).

Type 6. Two edges with barbs; long socket; rivet-hole (No. 220 c).

Pike (Pl. XLV).

The pikes have sockets, and either 1. circular section through point (No. 163), or 2. square section (No. 172).

Strigil (Pl. XLV).

Only a fragment is preserved (No. 222) representing a common type.

Chisel (Pl. XLV).

Only one specimen (No. 158 d) with splayed edge was found.

Nail (Pl. XLV).

The nails are all of large size and defaced in various ways. 1. No. 204 c has a large head and circular section, while others, 2. have large heads with square section (Nos. 158 b, c, 166, 175 a, f, 181 c, 187 e, 194 a, 205 f, 214 c, 231 d, 235 a, 241 a). 3. No. 178 d is provided with a small, thick head.

Pin (Pl. XLVI).

Three types are distinguished. 1. Circular section (Nos. 181 a, 194 c, 208 b). 2. Upper part with square section; towards the point, circular section (No. 181 b). 3. Upper part forked, circular section (No. 235 e).

R i v e t (Pl. XLV).

The two rivets represented are both of the same type with square cross section (Nos. 175 c, 220 d).

S t a p l e.

The staples are of the same type with more or less hooked or bent ends (Nos. 175 d, 182 c, 184 b, 241 b, 308 b).

R i n g (Pl. XLVI).

The rings are of two types. 1. Finger-ring, plain (No. 178 b). 2. Ring of larger size (175 e).

B r a c e l e t (Pl. XLVI).

The bracelet (No. 187 b) has a round section and somewhat flattened ends.

F i s h - h o o k (Pl. XLVI).

The type represented resembles very much the modern hooks (No. 202 b).

R o d (Pl. XLVI).

The rods have all square sections (Nos. 158 f, 162, 176, 191).

L o o p (Pl. XLVI).

These are represented by Nos. 194 b and 204 d, and are similar in shape.

C y l i n d e r (Pl. XLVI).

No. 182 d may have been a kind of bead.

D i s c (Pl. XLVI).

The discs are all of circular shape with a somewhat upturned edge (Nos. 198 b, 221 a, 231 a).

S h e e t (Pl. XLVI).

A great many bronze sheets were found, most of them being mere fragments of various objects the original shape of which it is difficult to state. 1. No. 221 b is of circular shape. 2. Nos. 221 c, e and 235 c are rectangular in shape, while 3. Nos. 156 and 232 b, c, are provided with a thick edge, whereas the opposite side is irregularly shaped. 4. Besides these types there are many irregular sheets (Nos. 158 g, 161, 173, 190, 204 e, 205 d, 208 c, 231 b, 235 d).

M o u n t i n g (Pl. XLVI).

The mountings are of various shapes depending upon their original purpose. 1. The most common shape is the circular, pierced mounting often used in connexion with staples (Nos.

175 b, 187 c, 205 c, 208 d, 214 b, 221 d, 254, 308 a). 2. No. 182 a may have been part of a helmet, and is segment-shaped. 3. The rectangular mounting No. 158 a may have served a similar purpose. 4. No. 227 may have been part of the peripheric band of a shield. 5. Mountings of irregular shapes (Nos. 182 b, 214 a, 219 c).

Ladle (Pl. XLVI).

Only the handles are preserved (Nos. 187 d, 204 b). One of them is provided with a goose's head (No. 187 d).

Bowl (Pl. XLVI).

All the bowls belong to a large type with splayed, flattened or plain rim. Only fragments are preserved (Nos. 149, 155, 183, 187 a, 219 b, 232 a).

Indeterminable tool (Pl. XLVI).

The purpose of the tool, No. 192, seems to be doubtful.

Silver.

Needle (Pl. XLVII).

The needle, No. 228 b, was provided with an eyelet.

Strip (Pl. XLVII).

The strips made of a hammered-out strip of silver are all of a similar type, though slightly varying in size (Nos. 204 f, 220 e, 228 a, 238).

Sheet.

The pieces of silver sheeting described under No. 228 c seem to be waste left after other figures have been cut out.

Gold.

Pendant (Pl. XLVII).

No. 240 is a pendant the original shape of which is uncertain.

Needle (Pl. XLVII).

The needle, No 239, is rather thick, square in cross section and provided with an eyelet.

Strip (Pl. XLVII).

The strips, No. 229 a, are similar to the silver ones.

Plaque (Pl. XLVII).

The stamped plaque, No. 229 b, is rectangular in shape and bears a representation of a bull.

Terracotta.

Antefix (Pl. XLVII).

The pieces of antefixes indicate that the same stamp was used for them all. They are palmette-shaped (Nos. 153 a—c, 201, 209).

Spindle-whorl (Pl. XLVII).

The shape is flat, circular, with hole in centre (No. 179).

Stone.

Button (Pl. XLVII).

The buttons Nos. 255 and 413 b resemble each other. They are circular with one side flat, the other somewhat convex. Four holes.

Bowl (Pl. XLVII).

No. 164 is square in outline, with a circular, shallow depression. For inscription, see Appendix IV. A minor shallow bowl is represented by the fragment, No. 196.

Glyptic.

Cylinder (Pl. XLVII).

The glyptic is represented only by the cylinder, No. 160.

Coins (Pl. XLVII).

The coin, No. 388, seems to be indeterminable*, while Nos. 217 and 218 are from Paphos, identical with Hill, *Catalogue of the Greek Coins of Cyprus in the Brit. Mus.*, Pl. VII, 12.

CONDITIONS OF FINDS

As to the finds made within the area excavated, they were found roughly speaking in two ways: 1. Finds which were preserved more or less in their original position, *in situ*. This does not mean that their exact original position could be determined, but that they evidently had not been greatly disturbed. 2. The second group consists of merely stray finds which could not with any degree of certainty be associated with any part of the architecture. These were simply found in layers the origin of which could only occasionally be determined.

The finds which can be associated with the sanctuary proper are, except some stray finds just outside its walls, e. g. Nos. 149, 154—158, some finds which were discovered lying on the white gypsum floor in Room I. The most prominent ones are the bronze reliefs Nos. 150—151,

* Mr. E. G. Robinson, *Brit. Mus.*, has kindly informed me in a letter that the coin is extremely rare. Only one more specimen is known (*Brit. Mus.*) also coming from Cyprus, which shows, according to Mr. Robinson that it must be a coin of one of the Cypriote cities. The weight is perfectly compatible with this, and the irregular incuse on the back is just of the type which is found on early coins of Idalium and Soli. Mr. Robinson dates the coin shortly before 500 B. C. There is no indication of what city we should assign it to.



Fig. 48. Vouini. The temple of Athena. The bronze cow, No. 152, *in situ*.



Fig. 49. Vouini. The temple of Athena. Spear-heads, Nos. 167 and 168, *in situ*.

and the bronze cow, No. 152. The former seem to have been applied on the inside of Wall 2 as they were found on the floor, leaning against the said wall. The bronze cow was found close by. Apparently the S. room in the sanctuary was used for storing offerings. No finds were made in the other two rooms. In front of the sanctuary some fragments of sculpture, all belonging to statuettes representing Athena, were discovered in position which may justify the suggestion that they had been placed on the terrace in front of the building. These are Nos. 210—213, 215, 216. The pit below the W. end of Wall 7 is worthy of special interest. In the layer containing ash and charcoal some minor objects were found, which, in accordance with the stratigraphical evidence, must be assigned to a period prior to the erection of the terrace building, Room II. The objects were found in the same layer, and this was recognized on both sides of the wall, Nos. 227—230, 238—241.

Another locality which produced some finds that must have been preserved more or less *in situ*, is Room VI. In the very corner between Walls 12 and 13 some bronze and iron weapons were found. Nos. 167 and 168 were found close together (Fig. 49). Not far from these, the iron dagger, No. 169, was found. Other finds from the same locality are Nos. 170—177, and 181. Nos. 178, 179 were found on the floor of Room VII.

These were the localities where certain finds could be determined as being preserved more or less *in situ*. A great many other finds were made all over the area, but as far as could be seen, their position were more or less accidental.

IDENTIFICATION OF THE TEMPLE

The question as to which deity the temple was sacred may be discussed. Unfortunately there are but few indications preserved, useful for the solution of the problem. The archi-

ture by itself does not show anything as far as our present knowledge allows a judgement. We have to confine ourselves at the finds, and in this respect the sculptures are important. Not less than eight pieces could be determined as representing the goddess Athena or being fragments of sculptures representing the same. Nearly all these sculptures were found in the close vicinity of the sanctuary, Room I. Certainly these finds justify the suggestion that the temple was sacred to Athena. This is confirmed by the inscription on the bronze bowl, No. 183, which was consecrated to Athena (cf. Appendix IV). Unfortunately the inscription on the marble bowl, No. 164, is fragmentary. The part with the name of the deity to whom the bowl was dedicated is missing. The rest of the finds, too, speak for the view that the temple was consecrated to Athena. Votive sculptures are comparatively rare, whereas the weapons predominate. Similar conditions seem to characterize other Cypriote temples sacred to the goddess mentioned. Reference is here given to the western, main acropolis at Idalion, which was sacred to Anat (cf. Vol. II, p. 628) and provided a great amount of weapons, but no votive sculptures.

There are also conditions which may explain why the temple was constructed and sacred to Athena. Below, it will be shown that the construction must have been about contemporary with the third building period in the palace. As this can be connected with the expedition of Kimon, the Athenian, to Cyprus, in 449 B. C., it may be pointed out that also the construction of the temple at the summit of Vouni should be connected with the same event. It is but natural that the capture of Marion, and evidently also Vouni, by the Athenians, resulted in the construction of a temple sacred to Athena on the summit of Vouni.

CHRONOLOGY

As to the relative chronology of the place, there is no other evidence than that mentioned in the Architectural analysis. Some offerings may have been made on the place already before the buildings were erected. The remainder of these offerings were collected in the pit below Wall 7, most likely in connexion with the erection of Walls 5—8. On a subsequent occasion the building, Room I, was added to the rear of the courtyard, Room II. This is the gradual development of building operations on the place. As regards the absolute chronology, the conditions certainly could be compared with the finds in the palace. If the finds of the Athena temple can be associated with finds from the palace it should be possible to fix the dates more accurately as the chronology of the palace is fairly well established. As has been mentioned above, only one sherd dating from the end of Cypro-Archaic II period was found. Such pottery was found below the floors of the earliest parts of the palace (cf. p. 283). The pottery found in the layers from the Athena temple is throughout of the same kind as the later pottery of the palace, from its 3rd and 4th periods (cf. p. 284). It seems therefore natural to connect the start of the building operations in the temple with the third building period of the palace. Such is the evidence of the pottery.

If we turn to the other finds we have to start with the coins. Three silver coins were found; the earliest of which can be dated shortly before 500 B. C. (No. 388). The two later

ones (Nos. 217 and 218) are alike, dating from the reign of Stasandros of Paphos (about the middle of the 5th century). Evidently the coin, No. 388, must be of a much earlier period than the pottery found on the place. As it was a mere stray find on the rock its significance for the chronology of the whole site may be doubtful. The two Stasandros coins, however, seem to be more in accordance with the date of the rest of the finds, and especially so the pottery.

The finds in the southern portion of Room I, the bronze sculptures, may also be dated to the middle of the 5th Century B. C. As no pottery of the Cypro-Archaic II period was found below the floor of Room I, but some which could be determined as belonging to the Cypro-Classic I period, it may be right to assume that the sanctuary, Room I, was added to the somewhat earlier, large terrace about the middle of the 5th century. Evidently the sculptures, especially those representing Athena, should be attributed to the same period (Style III A). The way in which the pieces were found indicates that they, too, should be associated with the same building.

On summing up the results it may be ascertained that the place was used for offerings during the first half of the 5th century. In this period, too, the large terrace-court was constructed. After the middle of the century the sanctuary, Room I, was added as a rear to the court. Nothing indicates when the whole temple-site was destroyed or abandoned. There are no finds which should be ascribed to a period later than the Cypro-Classic II period. The destruction of the temple may, therefore, have happened contemporaneously with the destruction of the palace (cf. below).

A. W.

The palace

ARCHITECTURE (Figs. 55—142; Plans IX—XXV)

ARCHITECTURAL ELEMENTS (FIGS. 55—118; PLANS IX, XVI—XXIII)

Stone walls.

The material used in the stone walls consists of the local limestone of the Vouni rock, and a kind of light-green, homogeneous limestone from a place called Paradisotissa, about 1.5 km. N. W. of Vouni. The Vouni limestone is of two kinds: one of a rather soft consistency, brownish or red-brown in colour; and the other of a harder structure, grey or whitish in colour. Both these limestones are coarse-grained and the second is full of small shells.

Quarries in Paradisotissa, around the palace and below its later parts (cf. below) show whence the blocks have been quarried.

All the stone walls are built of the Vouni limestone, except Walls 1—4 in which the Paradisotissa stone is used, and Walls 126—136, where this stone is used in parts, and Wall 64 B where some blocks are of *pouropetra*.

As a rule, only the foundations are built of stone, while the upper walls were of mud-brick



Fig. 50. Vouni. The central part of the palace area before excavation.

(cf. below). In Rooms 42—45, 85—93, however, the walls of the ground-floor are built entirely of stone. The foundations are usually well preserved, often up to their original height, which is proved by the fact that, as a rule, remains of the brick-walls were found on top of the stone foundations. The heights of the palace walls are always measured from the adjoining floors. Where nothing else is stated, the walls are founded on the rock.

A classification of the structural types of walls, and a description of the walls of each type are given below.

1. Single-faced ashlar wall.

The wall rests on a socle of well dressed ashlar rising only slightly above the floor-level. On this socle the stone wall is founded with a carefully built face of orthostatic ashlar blocks; the opposite face is built of large, sharp-edged stones. The filling between these faces consists of chips of stone and red earth from bricks. The rubble face is covered with a coating of lime-plaster and the blocks of the ashlar face, especially those of the socle, are partly bounded with lime-mortar.

*Wall 1. (Room 52.)**

Width: 1.10 m. Height: 0.50 m.

Parts of this wall are preserved up to its original height which is evident from the fact that remains of the brick-wall were found on top of the stone foundation; other parts, how-

* In order to facilitate the identification of the walls whose numbers are indicated on the analytical plan, Fig. 119, the figures of the rooms enclosed by the walls in question are added in brackets.

ever, are destroyed down to the socle. The wall is not bonded to Walls 73 and 155 and the facing of ashlar continues inside these walls. In the middle of the wall a wide doorway affords communication between Rooms 52 and 55. Close to this doorway, the wall is faced with ashlar blocks on both sides.

Wall 2. (Room 52.)

Width: 1.10 m. Height: 0.20 m.

Of this wall much less is preserved than of the preceding: most of it has been destroyed down to the socle. The wall is not bonded to Walls 73 and 155 but its facing of ashlar continues inside these walls. In the middle of the wall a wide doorway opens between Rooms 52 and 49, opposite that between Rooms 52 and 55. The wall is entirely destroyed at this doorway, but it is to be supposed that it was built of ashlar on both sides as Wall 1.

Walls 3—4. (Room 52.)

Width: 1.10 m. Height: 0.50 m.

These are cross walls between Walls 1 and 2. Parts are preserved to their original height; other parts are entirely destroyed. The walls are faced all round with ashlar. In the middle of the walls are doorways between Rooms 51, 52, and 53.

2. Double-faced shell wall with a face of laid ashlar.

The blocks are placed in horizontal, isodome courses, with occasional, orthostatic blocks here and there. The blocks are not dressed on the inside and do not meet in the middle of the wall, but the interstice is very narrow and is filled with chips of stone and earth. The lowermost course rests on a levelling stratum of chips of stone on the rock.

Wall 5. (Rooms 33, 34, 36.)

Width: 0.95 m. Height: 1.20 m.

Four courses are preserved. In the S.W. part of the walls, the ashlar rests on a socle of rubble, sometimes reaching a height of 0.50 m. The N. E. part of the wall is almost entirely destroyed; only one course is preserved and this rests on the rock. The wall is bonded to Wall 137.

Wall 6. (Room 36.)

Width: 1.10 m. Height: 0.75 m.

The wall is a continuation of the preceding and built at right angles to it; it is preserved up to three courses. This wall and the N. W. part of the preceding wall have been restored with rubble up to the floor-level of Room 36 in order to save this floor and the adjoining walls from complete destruction.

3. Double-faced shell wall of orthostatic and transverse, horizontal blocks.

Two classes may be distinguished, A and B; the former represented by Walls 7—11, the latter by Walls 12—14.

The walls of Class A are built of alternate courses of orthostatic blocks as stretchers and



Fig. 51. Vouni. The palace during excavation.
Female worker with masculine strength.



Fig. 52. Vouni. The palace during excavation.
Pause in the work.

transverse, horizontal blocks as headers. Usually the transverse blocks cover the whole width of the wall but sometimes horizontal blocks placed lengthways occur among the transverse blocks. The space between the orthostatic blocks is filled with earth and chips of stone.

The walls of Class B resemble those of Class A, but they are narrower, the blocks are smaller and thinner and more carefully cut.

Wall 7. (Room 14.)

Width: 1.05 m. Height: 1.10 m.

Two courses are preserved. The lower course consists of transverse blocks covering the whole width of the wall or blocks placed lengthways and almost meeting in the middle; the upper course is built of orthostatic blocks. The blocks are usually large in size and roughly dressed. The lower part of the inner face of the wall towards Room 14, consists of cut rock, on which the stone foundation is laid. The wall is bonded to Walls 15 and 18.

Wall 8. (Room 13.)

Width: c. 0.90 m. Height: c. 1.00 m.

Of this wall, only the N. W. part of the S. W. face, consisting of a shell of orthostates, is preserved. These blocks are built into Wall 76, forming its N. E. face towards Room 13. The rest of the wall has been demolished for the erection of Wall 76. If we assume that Wall 8 had approximately the same width as Walls 9—11, this reconstructed width corresponds to a rectangular excision in the rock below Wall 18. It seems therefore evident that Wall 8 ran immediately to the N. E. of Wall 76. Contrary to this wall, Wall 8 entirely separated Rooms 13 and 14 without a communicating doorway between them as will be shown below (p. 134). It is further to be assumed that the S. E. part of Wall 8 was founded on a rock-cut ledge in the same way as Walls 9—11 (cf. below). When the wall was demolished this ledge.



Fig. 53. Vouni. The palace during excavation.

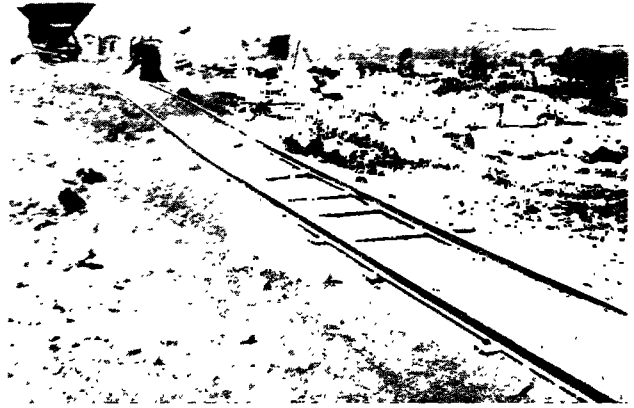

Fig. 54. Vouni. The palace during excavation.

too, was cut away, which explains the rectangular excision in the rock below Wall 18. The poor remains of the wall give no evidence of its original construction, but it is to be assumed that it was of the same type as the corresponding Walls 9—11.

Wall 9. (Room 13.)

Width: 1.10 m. Height: 1.45 m.

The wall consists of three courses of alternating orthostatic and transverse blocks, the lowermost being orthostatic. Of the uppermost course only a few blocks close by Wall 18 are preserved. Towards this wall where the rock rises, Room 12, as well as Rooms 10, 11, 13, and 14, is partly cut out of the rock and the wall is there founded on a projecting rock ledge. The sloping top of this ledge is levelled by a course of rubble. The N. W. end of the wall consists of a large, orthostatic block. The wall abuts against Wall 18.

Wall 10. (Room 12.)

Width: 1.10 m. Height: 1.30 m.

This wall differs from the preceding in that some of the blocks in the course of headers are not transverse, but placed lengthways. In some cases where the blocks of one course are not of exactly equal height, the interstices are filled with small stones. The wall abuts against Wall 18.

Wall 11. (Room 11.)

Width: 1.10 m. Height: 1.50 m.

This wall is identical in construction with Wall 9. It abuts against Wall 18.

Wall 12. (Room 26.)

Width: 0.80 m. Height: 0.82 m.

The wall is built with a bottom course of orthostatic blocks and a covering course of horizontal, transverse blocks. The covering course is missing on the N. E. part of the wall. At the N. E. end of the wall a staircase leads up from Room 25 to Room 28. The wall is not properly bonded to Wall 157 which is a rubble wall (cf. below), but two blocks on a level

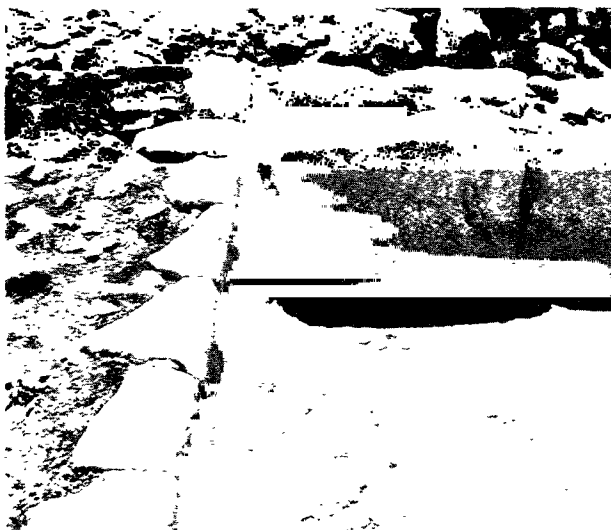

Fig. 55. Vouni. The palace. Walls 1 (left) and 73 (right).



Fig. 56. Vouni. The palace. Walls 1 (background, left), 73 (foreground, left), and 155 (right). Part of inner face of Wall 155 removed in order to show the structural interrelations of the walls. Part of Walls 126, 127, and the staircase between Rooms 57 and 65 furthestmost in the background.

with the covering course of Wall 12 are placed across the joint between this wall and Wall 157.

Walls 13—14. (Rooms 66, 68.)

Width: 0.90 m. Height: 0.16 m.

Only a single course of transverse blocks is preserved, resting on a levelling stratum of chips of stone. Wall 14 is built at right angles to Wall 13 and is a continuation of this wall to the S. E. construction. The further continuation of the wall to the S. E. by Wall 86 is of other construction (cf. below, p. 136).

4. Double-faced shell wall of orthostates alternating with horizontal blocks placed lengthways.

The walls are built of alternate courses of orthostatic and horizontal blocks placed lengthways. These latter are not dressed on the inside and do not reach the middle of the wall. Occasional transverse blocks occur among the orthostates.

There are two classes of this mural type:

A. These walls are usually built of large-sized, heavy blocks; the faces are often roughly coursed and the filling between the blocks consists of chips of stone and earth (Walls 15—20).

B. These walls are built of thinner blocks, the joints are better adjusted and coursed. The filling is usually mixed with lime-mortar which also is used in the joints of the blocks. Some of the walls of this class have only the bottom course of orthostatic blocks preserved, and it may be questioned if the stone foundation of some of these walls consisted of more than this bottom course (Walls 21—49).



Fig. 57. Vouni. The palace. Part of staircase between Rooms 55 and 64, traces of Wall 129 and Wall 130 (right), Wall 131 (background).

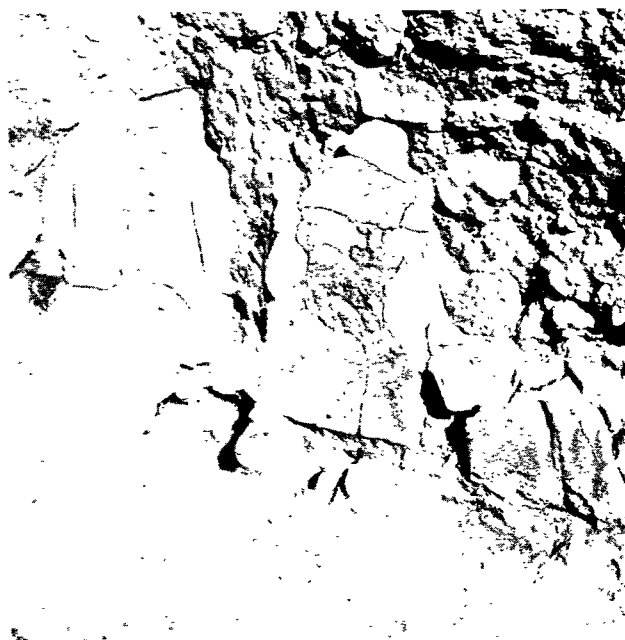

Fig. 58. Vouni. The palace. The corner between Walls 129—131.

Wall 15. (Rooms 10—14.)

Width: 1.25 m. Height: 1.20 m.

The wall is very solidly built of large-sized, heavy ashlars. The construction of the outer and inner faces differs. On the outside the lowermost course consists of orthostatic blocks; on the inside of two superimposed, horizontal blocks placed lengthways. This difference is due to the slope of the rock: this slopes to the N. and N. W., and its level on the outside of the wall is as much as 0.80 m. below that on the inside. In order to obtain a horizontal top for the courses of blocks, the rock was not levelled, but the method was chosen of placing two horizontal blocks in the inner face approximately equalling in height one orthostate in the outer face. Smaller differences were adjusted by means of chips of stone. Towards the gateway in Room 14 the construction of the wall changes to one of Type 6 (cf. below) by the insertion of some transverse, orthostatic blocks. The gateway has been blocked up later, with huge ashlars of which only one was preserved. The wall is bonded to Walls 7 and 16.

Wall 16. (Room 10.)

Width: 1.00 m. Height: 1.25 m.

This wall is built at right angles to the preceding wall and is bonded to it. In the wall is a doorway leading into Room 10. To the S. E. the wall is continued without a break by Wall 17. N. W. of the doorway only the bottom course of the wall is preserved. This consists of horizontal blocks placed lengthways, with a levelling layer of chips of stone. S. E. of the doorway, the wall is preserved for two courses and is built with a bottom course of horizontal blocks placed lengthways.



Fig. 59. Vouni. The palace. Walls 73 (left) and 155 (right) in the foreground. Part of the core of the latter wall removed. Foremost in the background: Wall 1; furthest: Walls 35, 126, 127, and the staircase between Rooms 57 and 65.



Fig. 60. Vouni. The palace. Entrance into Room 95, with the doorway narrowed by later additions.

Wall 17. (Room 16.)

Width: 1.10 m. Height: 0.90 m.

This wall, as mentioned above, is a continuation of Wall 16. In the middle of the wall, is a doorway communicating between Rooms 16 and 17.

Wall 18. (Rooms 10—14.)

Width: 1.05 m. Height: 2.40 m.

Three courses are preserved: a bottom course of large, orthostatic blocks, then a course of horizontal blocks placed lengthways, and a top course of orthostatic blocks. Occasionally transverse, orthostatic blocks are inserted between the facing orthostates. The lower part of the face towards Rooms 10—14 consists of cut rock on which the stone foundation is laid; in Room 14 aligned with the vertical rock wall, in Rooms 10—12 about 0.10—0.30 m., and in Room 13 about 1.00 m. inside the rock-cut wall. The construction of the stone wall displays some irregularities on account of the uneven rock surface. Thus the face of Room 12 is built of a bottom course of horizontal blocks placed lengthways and large, square, orthostatic blocks with two horizontal blocks placed lengthways in order to reach the level of the horizontal, transverse blocks of Wall 9; two such large, square blocks occur in the face of Room 10, too; smaller irregularities are levelled with chips of stones, which sometimes are also used as wedges between the large blocks. The wall is not bonded to Walls 9—11 and 76, which abut against it, but it is bonded to Wall 7.

Wall 19. (Room 47.)

Width: 1.00 m. Height: 0.35 m.

This wall consists of a bottom course of orthostates and a covering course of horizontal blocks placed lengthways, which are visible above the floor, while the bottom course of orthostates are below it.

Wall 20. (Room 33.)

Width: 1.05 m. Height: 0.12 m.

This wall is almost entirely destroyed. Only two blocks are preserved, but it seems to have been of the same type as the preceding one.

Wall 21. (Room 97.)

Width: 1.10 m. Height: 0.80 m.

This wall, as the subsequent ones, is a representative of Class B. It rests on a socle of rubble bound with lime-mortar. The lowermost course is orthostatic and of the second course of horizontal blocks placed lengthways only two ashlar are preserved. The wall is bonded to Walls 25 and 26.

Wall 22. (Room 97.)

Width: 1.10 m. Height: 0.50 m.

This wall is similar to the preceding one and rests on a socle of the same construction as in that wall. To the S. E. this socle is raised, and in this part of the wall the lowermost course consists of horizontal blocks placed lengthways which are thus on a level with the top of the orthostatic blocks in the other part of the wall. Only this bottom course is preserved. The wall is bonded to Walls 25 and 26.

Wall 23. (Room 95.)

Width: 1.10 m. Height: 0.30 m.

This wall is much ruined and only some of the orthostatic blocks of the bottom course are left, but the inner filling of chips of stone mixed with lumps of lime-mortar was still preserved. The wall is bonded to Wall 26.

Wall 24. (Room 95.)

Width: 1.10 m. Height: 0.80 m.

Of the face towards Room 94 only the bottom course is preserved. This consists of horizontal blocks placed lengthways. On top of this are two courses of orthostatic blocks which are only preserved on the face towards Room 95. The filling between the blocks consists of large and small, worked stones mixed with lime-mortar. The wall is bonded to Wall 25.

Wall 25. (Rooms 95—97.)

Width: 1.10 m. Height: 0.60 m.

This wall encloses Rooms 95—97 to the S. E. It is of the same construction as the preceding walls. Smaller irregularities are due to the considerable differences in levels of the rock which slopes to the N. E. and levelling courses are therefore inserted here and there. The wall is bonded to Walls 21, 22, and 24, but not to Wall 23.

Wall 26. (Rooms 94—97.)

Width: 1.10 m. Height: 0.65 m.

This wall encloses Rooms 94—97 to the N. W. It is interrupted by doorways leading into these rooms. The sides of the doorways are revetted with orthostatic blocks. The original doorways of Rooms 95 and 96 are, however, narrowed on a later occasion by added pieces of rubble. Two short offsets of walls, 1.75 m. long, project from the wall at the entrance to Room 96. These projections are contemporary with the original wall. Only the bottom course of orthostatic blocks is preserved. The wall is not bonded to Wall 24 but to Walls 21—23.

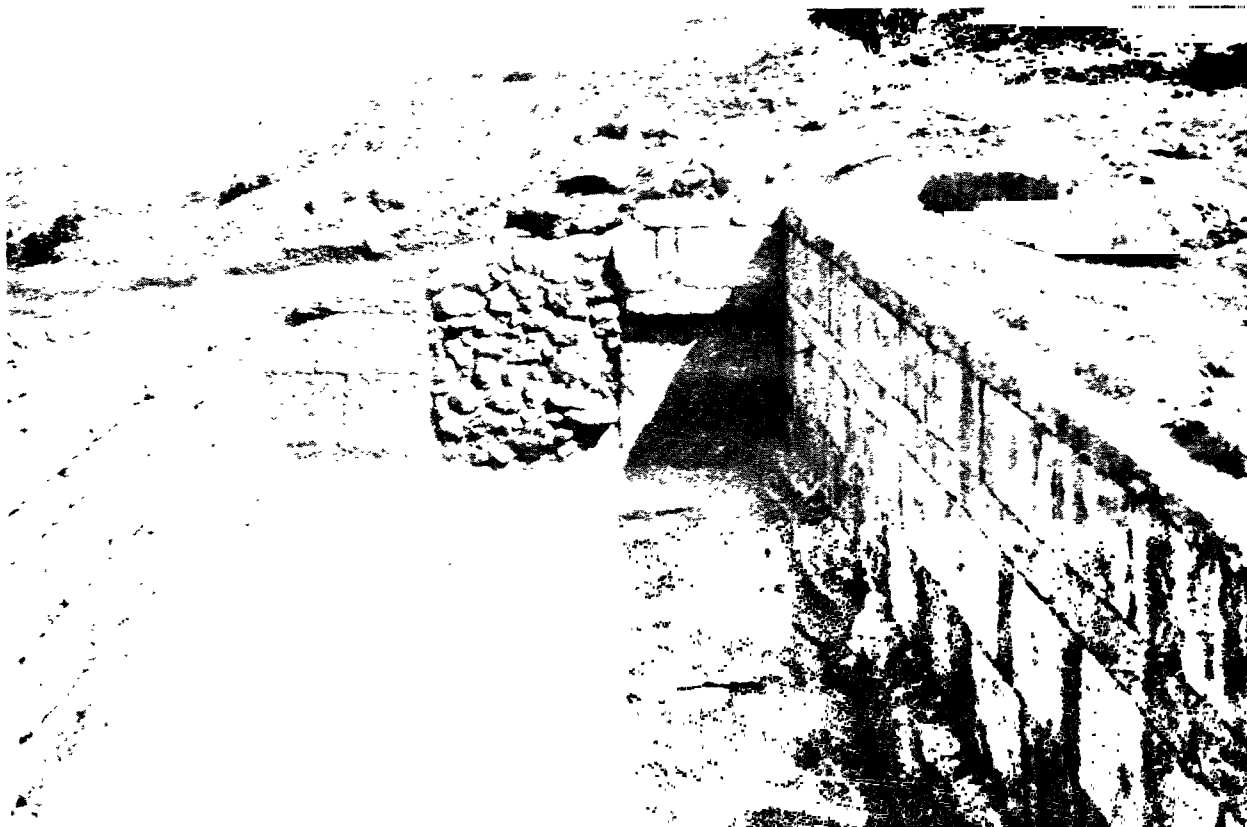

Fig. 61. Vouni. The palace Room 93. Walls 68 (right), 69 (left), and 71 (background), with the doorway blocked up.

Wall 27. (Room 94.)

Width: 1.10 m. Height: 0.25 m.

The type of this wall cannot be ascertained as only a part of the levelling stratum of rubble of the rock is preserved but most probably it was of the same construction as the preceding walls. It is to be noticed that the wall is aligned with Wall 71 but not with Wall 25, and the corner construction of the latter wall shows that it cannot have been bonded to Wall 27. These irregularities are explained by the fact that Rooms 94—97 were built in a later period than Rooms 92 and 93 (see Architectural analysis, p. 194).

Wall 28. (Room 100.)

Width: 1.55—1.70 m. Height: 0.55 m.

The bottom course consists of well dressed, horizontal blocks placed lengthways and on account of the width of the wall three blocks abreast. In the middle of the wall a wide door opened with the holes for pivots and door-jambs preserved (cf. below, p. 146). S. E. of the doorway a second course of orthostatic blocks is preserved. The filling between the blocks consists of small stones and lime-mortar; in the filling between the orthostates is also a large block inserted for strengthening purposes. The joints of the blocks, too, are often filled with lime-mortar and small stones.

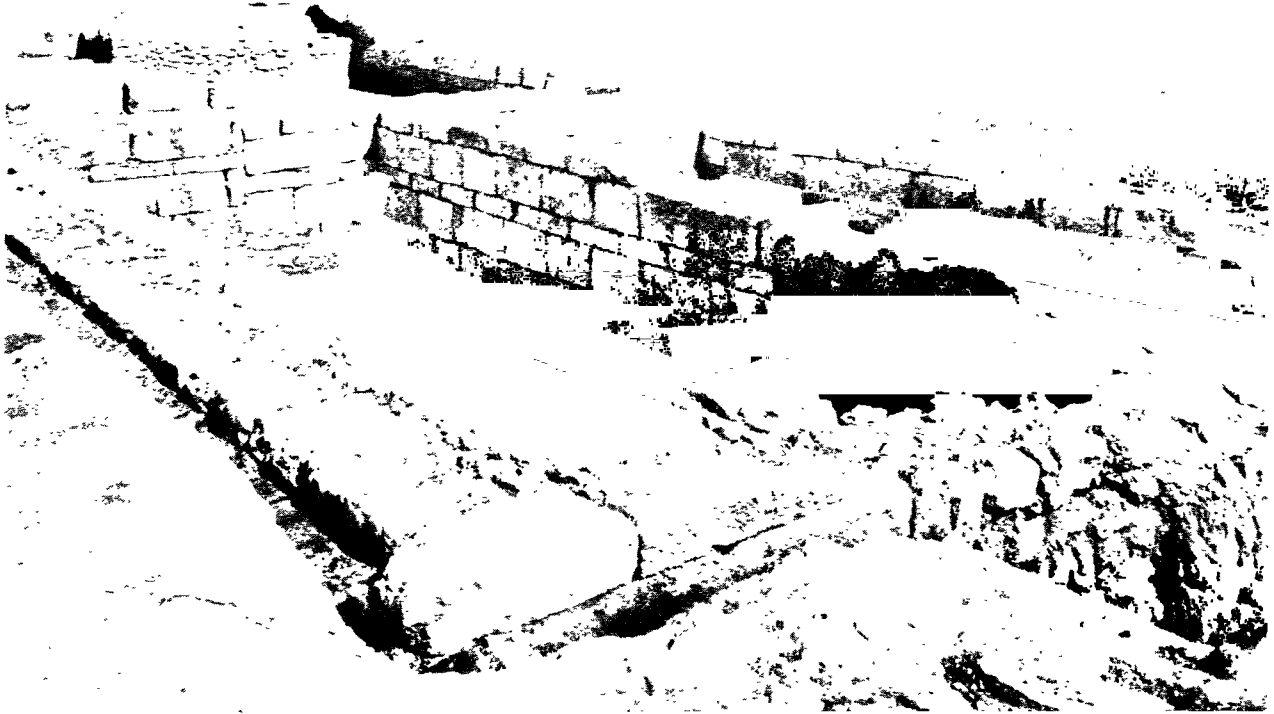

Fig. 62. Vouni. The palace. Walls of Rooms 93 (left) and 92 (right).

Wall 29. (Room 100.)

Width: 0.55 m. Height: 0.50 m.

This wall is rather thin; it is about half as wide as the preceding walls. The lowermost course consists of orthostatic blocks placed opposite each other. If a block on one side is shorter than that on the opposite side the interval is filled with smaller stones. The filling between the blocks consists of earth and chips of stone. Only the bottom course is preserved. On account of the small width of the wall the next course, if there ever was one, cannot have been formed by horizontal blocks placed along both faces of the wall, but may have consisted of horizontal blocks, placed lengthways and covering the whole width of the wall, as on Wall 65 (cf. below). There is a doorway in the wall between Rooms 81 and 100. The wall is not bonded to any of the adjoining walls. The sides of the doorway were revetted by transverse blocks; that on the N. W. side is missing.

Wall 30. (Room 100.)

Width: 0.75 m. Height: 0.65 m.

This wall is somewhat narrower but of the same construction as Walls 21 ff. The blocks rest on a substruction of undressed stones levelling the cavities of the rock. A waste-conduit of stone (see p. 171) is built into the wall of Room 76. Only a part of the bottom course of orthostatic blocks is well preserved; the S. W. part of the wall enclosing Room 73 is almost entirely destroyed. The wall is not bonded to any of the adjoining walls.



Fig. 63. Vouni. The palace. Room 97. Walls 25 (foreground), 21 (left), 22 (right), and 26 (background).

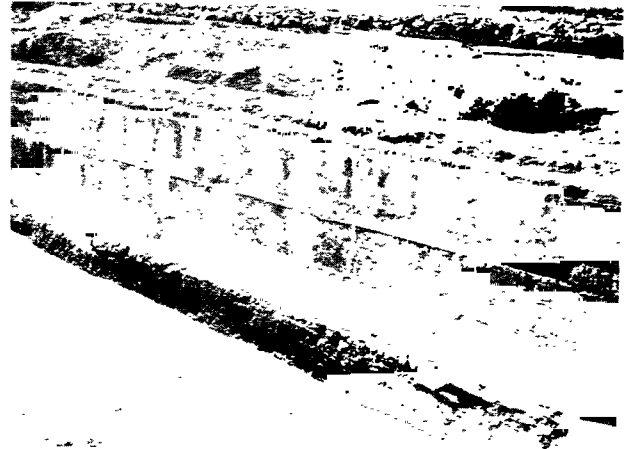

Fig. 64. Vouni. The palace. Wall 68.

Wall 31. (Room 73.)

Width: 0.72 m. Height: 0.12 m.

This wall is not well preserved, but has probably been of the same construction as the preceding. It rests on a substruction of large ashlar. Only a few orthostatic blocks of the bottom course are preserved.

Wall 32. (Room 74.)

Width: 0.70 m. Height: 0.30 m.

The wall is of the same type as Walls 29 ff. The doorway between Rooms 73 and 74 is revetted by an orthostatic, transverse block. The wall is not founded on the rock but in the debris below the floor. Only the bottom course of orthostatic blocks is preserved above the floor and some of the blocks are missing.

Wall 33. (Room 73.)

Width: 0.70 m. Height: 0.20 m.

This wall is a continuation of the preceding, built at right angles and bonded to it. The S. E. part of the wall is missing.

Wall 34. (Room 57.)

Width: 0.80 m. Height: 0.65 m.

This wall has a bottom course of orthostates of rather unequal size. If the stone wall ever consisted of more than this bottom course is uncertain, as in Walls 29 ff. In the N. W. part of the wall is another transverse block, forming the S. E. flank of a wide doorway opening between this wall and Wall 57.

Wall 35. (Room 57.)

Width: 0.80 m. Height: 0.65 m.

This wall is built at right angles to the preceding, to which it is bonded and is of the same construction. At the N. E. end of the wall is a staircase leading to Room 65.

Walls 36-40. (Rooms 113, 114.)

Width: 0.85-1.05 m. Height: 0.20-0.90 m.

These walls are all of the same construction. Rooms 113 and 114, enclosed by the walls, are partly cut in the rock, so that the lowermost part of the faces of the walls is rock-cut.



Fig. 65. Vouini. The palace. Room 12. Walls 15 (foreground), 9 (right), 10 (left), and 18 (background).



Fig. 66. Vouini. The palace. The S. E. part of Room 13 with the rock cavity after excavation. Walls 76 (foreground), 18 (right), 9 (foremost in the background), and 10 (furthermost in the background).

In the substructure of the walls horizontal, transverse blocks are used occasionally. The bottom course of the N. E. face of Wall 40 has orthostates on the outside and horizontal blocks placed lengthways on the inside.

Walls 41—44. (Room 101.)

Width: 1.10 m. Height: 0.15—0.80 m.

These walls enclose Room 101. The material consists of blocks of soft Vouini rock. In Wall 41 some transverse blocks are inserted between the facing orthostates so that the wall properly belongs to Type 6 (p. 128). In Wall 42 there is a bottom course of horizontal blocks placed lengthways except in the N. E. part of the wall where there are orthostates on account of the sloping rock. Wall 43 is almost entirely destroyed. The entrance of the room is in Wall 44. To the right of the entrance are two orthostatic blocks forming an angle. The filling of the walls consists of small stones and earth mixed with soft lime-mortar.

Wall 45. (Room 126.)

Width: 1.00 m. Height: 1.35 m.

The material consists of roughly cut blocks of Vouini rock. The face of Room 122 is built of three courses horizontal blocks placed lengthways, except the S. E. end, where the rock slopes and the isodomic structure is kept by using one horizontal and one orthostatic course corresponding to the three horizontal courses in the other part of the wall. The face of Room 126 is built with a levelling bottom course with rubble in the interspaces; then, a course of orthostatic blocks, and on top of that a horizontal course of ashlar placed lengthways. Lime-mortar is used at the joints. The wall is not bonded to any of the adjoining walls.

Wall 46. (Room 126.)

Width: 1.00 m. Height: 0.80 m.

The wall consists of a bottom course of orthostates and on top of that horizontal blocks placed lengthways. Only these two courses are preserved, and in the N. E. part of the wall

even the second course is missing. In the joints between the blocks is lime-mortar and occasionally a filling of small rubble. The wall is not bonded to the preceding one.

Wall 47. (Room 126.)

Width: 0.97 m. Height: 0.80 m.

This wall is of the same construction as the preceding one. The second course of horizontal blocks placed lengthways is better preserved. The wall is not bonded to Wall 45.

Wall 48. (Room 127.)

Width: 1.00 m. Height: 1.15 m.

The four lowermost courses are built of superimposed, horizontal blocks placed lengthways; on top of these is a course of orthostates. The top course is only preserved close to Wall 173. The wall is not bonded into that wall. Lime-mortar is used in the joints. A raised platform consisting of a single row of rectangular stone slabs revets the base of Walls 47, 173, and 48 in Room 127.

Wall 49. (Room 128.)

Width: 1.00 m. Height: 1.15 m.

The wall is of the same construction as the preceding one but only the two lowermost courses of horizontal blocks placed lengthways are preserved. The face of Room 129 has orthostates in the lowermost course. The wall is not bonded to Wall 173.

5. Double-faced shell wall as Type 4, but with a core of chips of stone and much hard lime-mortar.

Occasionally the walls are built of courses of orthostatic blocks only, as the core was considered solid enough to dispense with headers, but usually courses of horizontal blocks placed lengthways alternate as headers with the stretchers of orthostatic blocks. Not seldom two courses of orthostatic blocks occur between the courses of horizontal blocks. Occasionally a transverse block is inserted between the orthostatic, facing blocks. The joints of the ashlar are bound with hard lime-mortar and the face is partly covered with a calcareous plaster.

Wall 50. (Room 82.)

Width: 1.20 m. Height: 2.70 m.

This wall is the most imposing of those preserved in the whole palace. It is very solidly and carefully built of well dressed ashlar revetting the hard core of chips of stone and lime-mortar. The wall rests on a substructure of rubble levelling the irregularities of the rock. In the lower part of the facing, two courses of orthostatic blocks alternate with one course of horizontal blocks placed lengthways. It is possible that the faces were entirely covered by a calcareous plaster but this is only preserved on the surface around the joints. The preserved height shows that almost the whole wall of the ground-floor was built of stone. In the S. W. part of the wall is a doorway communicating between Rooms 46 and 78—83. To the N. E., between Rooms 42 and 84, there is a large hole in the wall, apparently made after its erection. In the face of Room 84, it can be seen that the half of an orthostatic block



Fig. 67. Vouni. The palace. Room 88. Walls 59 (left), 60 (right), and 70 (background).

Fig. 68. Vouni. The palace. Room 86. Walls 61 (left), 63 (right), and 58 (background).

has been cut off and the lower part of the superimposed block has been hollowed out so that the hole had an arched upper end; on the face of Room 42, on the other hand, it is evident that a whole block of the orthostatic ashlar has been removed, and replaced by a square block, half the length of the former one, and of another kind of limestone than the blocks of the original wall. The block in the superimposed course has been trimmed off like a block in a corbel-vault. The surface of the wall around the hole was covered with smoke. Inside, the hole is covered with thick remains of lime-mortar, which show traces of an object, having filled up the hole; what object will be discussed later (pp. 228 f.). It is further to be remarked that on the face of Room 42 there is a horizontal groove, square in section, about 0.90 m. above the floor, and a square hole immediately below the groove S. W. of the large hole mentioned above. The groove and the hole are filled with lime-mortar. The groove continues along Wall 52 and similar, square holes occur in that wall, too (cf. below).

The part of the wall between Rooms 41 and 85 is not visible above the floor. It was demolished to below the floor-level of Room 41 when Walls 63 and 64 A were built and the stone slabs floor of this room was laid on top of the demolished wall (cf. Architectural analysis, p. 192).

The wall is bonded to Walls 56, 91, 53, 52 but not to Walls 51 and 58.

Wall 51. (Room 42.)

Width: 1.10 m. Height: 0.80 m.

Of this wall, only two courses of orthostatic blocks are preserved. The wall is not bonded to Wall 50. At the N. W. end a doorway communicates with Rooms 40 and 42.

Wall 52. (Room 42.)

Width: 1.00 m. Height: 1.95 m.

A characteristic feature of this wall is a horizontal groove, square in section, which runs through the wall, about 0.90 m. above the floor. The groove is coated with lime-mortar. Immediately below this groove are three square holes through the whole width of the wall.



Fig. 69. Vouni. The palace. Walls 56, 133, and staircase between Rooms 46 and 60 (foreground, left), Wall 191 (foreground, right), Walls of Rooms 48—56 and the staircase between the central court and Rooms 48—51—54 (background).

It seems certain that wooden, transverse beams were fitted into the holes and that a wooden board rested on them and was inserted in the groove along the wall. The purpose of such a wooden bench will be discussed later (p. 204). The mural technique differs from the other walls of this type in that all the courses are orthostatic. The wall is bonded to Walls 50 and 54.

Wall 53. (Room 45.)

Width: 1.00 m. Height: 2.00 m.

The face of Room 45 is regularly built of alternating orthostatic and horizontal blocks placed lengthways. A part of the face of Rooms 43 and 44 is more irregularly laid, the third and fourth course from the bottom being both orthostatic. The wall is bonded to Walls 50, 54, and 55.

Wall 54. (Room 44.)

Width: 1.00 m. Height: 1.60 m.

The N. E. part of the wall is of the same structure as Wall 52, to which it is bonded; the

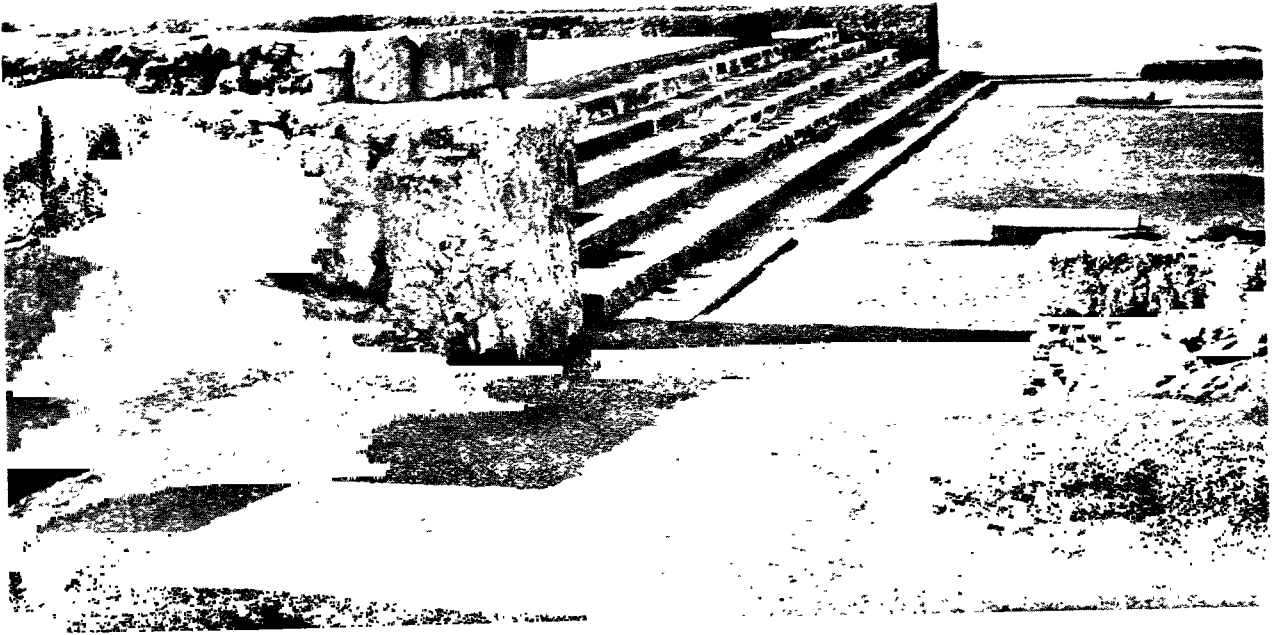

Fig. 70. Vouini. The palace. In the foreground: Walls 55 and 133; in the background: Walls of Rooms 48—51—54 and the staircase (after restoration) between these rooms and the central court.

S. W. part is of the same structure as the adjoining part of Wall 53, to which it is bonded. Between these two parts, there was originally a doorway which was later blocked up with rubble and roughly dressed blocks.

Wall 55. (Room 45.)

Width: 1.00 m. Height: 1.55 m.

This wall is a continuation of the S. W. part of Wall 54 and of the same structure. It is bonded to Wall 53.

Wall 56. (Room 46.)

Width: 1.00 m. Height: 1.60 m.

The wall is bonded to Wall 50 and of the same construction. Three courses of blocks are preserved in the S. E. part of the wall. On a substructure of horizontal blocks there are two superimposed courses of orthostates, and a third course of horizontal blocks placed lengthways. A stairway opens in the wall, communicating between Rooms 46 and 60 (cf. p. 157).

6. Double-faced shell wall of so-called box-wall type.

The walls are built of alternate courses of orthostatic and horizontal blocks placed lengthways, but between the facing, orthostatic blocks, transverse blocks are inserted across the wall. In this way, a series of rectangular "boxes" are formed with the long sides formed by the facing, orthostatic blocks and the short sides by the transverse, orthostatic blocks, the bottom and lid by the horizontal blocks placed lengthways. Such transverse blocks occur occasionally in some of the walls of the preceding types, too, as shown by the description of the walls, but there they are only used sporadically and do not form a characteristic, structural element. The boxes are filled with chips of stone, gravel, earth, and lime-mortar. The joints of the blocks are usually filled with lime-mortar. There are however several classes of this mural type as is shown by the description of the walls:

A. This is a primitive type with the transverse blocks placed irregularly and obliquely in the wall, and the filling consists only of small stones and earth; no lime-mortar is used in the joints but small wedging stones (Wall 57).

B. The filling in the walls of this type consists of a compact layer of rather soft lime-mortar and chips of stone; between the joints of the blocks are small wedging stones and lime-mortar; the transverse, orthostatic blocks are few, at least in parts of the walls (Walls 58—67).

C. This class may be considered as the typical box-wall. Still the construction displays some irregularities: there are transverse blocks, between every facing orthostate, or between every second and third one; sometimes there are courses of orthostates without transverse blocks; the two lowermost courses are usually of such construction; sometimes there are two, superimposed courses of facing and transverse orthostates without an intermediate course of horizontal blocks placed lengthways, etc. The filling consists of small stones, earth, and lime-mortar, but the mortar is not abundantly used. As a rule, the joints are filled with lime-mortar (Walls 41 [described together with Walls 42—44, p. 123], 68—72).

D. This type consists of a single course of facing, orthostatic blocks with transverse blocks between every second pair of facing blocks; the facing blocks are unusually thick and the wall is not so wide as the other box-walls, so that the boxes are rather narrow (Wall 73).

E. This class has abundant lime-mortar in the filling as the walls of B, but the lime-mortar is of a harder consistency and in the long walls, the construction is of a more regular box type than B, with transverse blocks between each, or every second, facing orthostate; the short walls, however, are less regular (Walls 74—76).

Wall 57. (Room 27.)

Width: 1.00 m. Height: 0.80 m.

The wall is built with a bottom course of orthostatic facing blocks with transverses between, placed obliquely across the wall, and an upper course of horizontal blocks placed lengthways. The blocks are roughly dressed and of unequal length and height; the difference in height is levelled by layers of small stones. Small wedging stones occur in the joints and the inner filling consists of small stones and earth. The N. W. part of the wall is almost entirely destroyed.



Fig. 71. Vouni. The palace. Room 43—44. Wall 52;
Wall 183 has been removed.

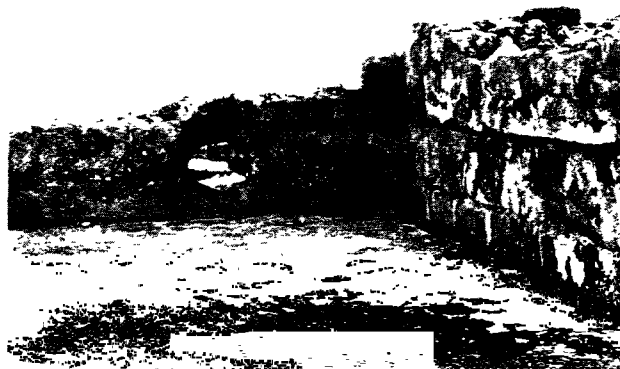

Fig. 72. Vouni. The palace. Room 42. Walls 50
(background) and 52 (right).

Wall 58. (Rooms 86—88.)

Width: 1.10 m. Height: 2.20 m.

The S. W. parts of Rooms 86—88, where the rock rises, is partly cut out of the rock and the lower part of the N. E. face of the wall is aligned with this rock-cut wall. In the W. corner of Room 88, between Walls 60 and 72, there was originally a doorway by which Room 88 communicated with the S. E. court of the palace (Rooms 80—83). This doorway was later blocked up with small wedging stones and ashlar blocks of the same kind as used in the wall, but the joint is very conspicuous (Plans XX, 1; XXII, 2). The original wall ended with transverse blocks in the courses of orthostates, by which a vertical flank of the doorway was obtained, as was often practiced in the ashlar walls. There are some irregularities in the face of Room 83, opposite Room 87. In the wall of Room 85, a hole has been opened for a water-conduit. In the face of Room 84, an orthostatic block has been removed and partly replaced by lime-concrete. The block in the superimposed course has been hollowed out underneath in order to make room for the water-conduit, and on the opposite face, i. e. of Room 85, a large block has been cut through the middle.

The wall is built of a levelling course of blocks at the bottom and on top of that courses of orthostates and horizontal blocks placed lengthways. On account of the irregular slope of the rock, which necessitated the insertion of levelling blocks, and the partial repair of the wall mentioned above, the faces of the wall are not regularly coursed. Three to four courses are preserved. Transverse orthostatic blocks occur sporadically in the lower courses, but in the uppermost of the preserved courses, they are more frequently used (see face of Room 86, Plan XXI, 3). The wall is bonded to Walls 60—64 A, but not to Wall 50.

Wall 59. (Room 88.)

Width: 1.00 m. Height: 1.65 m.

The S. W. part of the wall is founded on a rock-cut ledge forming the lower part of the face in Room 88 (cf. above). The irregularities of the rock below the wall are levelled with small stones and lime-mortar. Three courses are preserved and they are all orthostatic.

Transverse blocks are inserted between every second of the facing block in the two upper courses. Along the S. E. face of the wall runs a socle of stone slabs projecting 0.25 m. outside the wall. This socle abuts on Wall 66 and does not continue inside this wall. The wall is bonded to Walls 62 and 70.

Wall 60. (Room 88.)

Width: 1.00 m. Height: 2.05 m.

This wall is founded on a rock-cut ledge, as is the preceding one. At the bottom is a levelling course; on top of this are preserved three courses of orthostates and parts of a fourth course of blocks close by Wall 58. Towards Wall 62 the wall is much destroyed. A few transverse blocks are found in the preserved part of the wall, but they may have been used more frequently in the destroyed, upper part of the wall as was the case in Wall 58 (cf. above). The wall is bonded to Wall 58 but not to Wall 62.

Wall 61. (Room 87.)

Width: 1.10 m. Height: 2.00 m.

The construction of this wall is similar to that of the preceding ones. At the bottom is a levelling course partly consisting of horizontal blocks placed lengthways, and close by Wall 58 remains of a fourth course. In the face of Room 86 especially, several blocks are inserted between the facing orthostates. Towards Wall 62 the wall is much destroyed, as in the preceding walls (only two courses being preserved). The wall is bonded to Walls 58 and 62.

Wall 62. (Rooms 85—88.)

Width: 1.00 m. Height: 0.80 m.

This wall is pierced by three doorways leading into Rooms 86, 87, and 88 respectively. The wall is founded on a substructure of small stones and lime-mortar, levelling the irregularities of the rock. The wall is much destroyed: in part only the bottom course of horizontal blocks placed lengthways is preserved, but in the part of the wall running along Rooms 86 and 87, there are remains of the second orthostatic course, and the third course of horizontal blocks placed lengthways.

As far as preserved, the wall is of the same construction as the preceding walls. No transverse blocks are found, except as usually in the flanks of the doorways but the inconsiderable height of the wall may explain the absence of the transverse blocks as these usually occur in the upper courses of the preceding walls. As Wall 62 is of the same construction in all other respects, we are therefore justified in including it in the B variety of so-called box-walls. The wall is bonded to Walls 59 and 61 but not to Walls 60 and 63.

Walls 63 and 64 A — B. (Rooms 41, 85.)

Width: 1.25 m. (Wall 63); 1.05 m. (Wall 64 A); 1.00 m. (Wall 64 B).

Height: 2.45 m. (Wall 63); 2.25 m. (Wall 64 A); 1.40 m. (Wall 64 B).

These walls are of a particular construction necessary for their purpose. In Walls 63 and 64 A four small, almost quadratic boxes are built of ashlar blocks, and in Wall 64 B there are three. The boxes of Walls 63 and 64 A open on to the narrow passage between the walls, and those of Walls 64 A and B to Room 41 as well. Upwards the boxes taper into narrow



Fig. 73. Vouni. The palace. Walls of Rooms
103—105.



Fig. 74. Vouni. The palace. Walls of Room 101.

holes and the walls end in a corbel-vault over the narrow passage between them. Walls 63 and 64 A are founded on the rock and Wall 64 B on the floor of stone slabs in Room 41. Walls 63 and 64 A are bonded into Wall 58 but Wall 64 B is not bonded to any of the adjoining walls.

Ash and carbonized matter found in the boxes and traces of fire on the stone blocks indicate that fires have been lit there, and the whole structure is to be interpreted as a heating room from whence hot air was conducted through the holes in the walls to a room above, the sudatory of a bath (cf. below Architectural synthesis, pp. 212 f.). One of the blocks used in Wall 64 B was incised with the letter \pm (pa).

Wall 65. (Room 41.)

Width: 0.65 m. Height: 0.60 m.

This wall is a box-wall of a construction similar to Walls 58 ff. It is, however, narrower than these walls and the courses of horizontal blocks placed lengthways are therefore formed by single blocks covering the whole width of the wall. The wall is not bonded to any of the adjoining walls. The filling below the floor of Room 40 (cf. below, Stratification, p. 180 and Architectural analysis, p. 193) was dug through down to the rock for the erection of the wall.

Walls 66—67. (Room 91.)

Width: 1.10 m. Height: 0.75 m.

The characteristic feature of these walls are the two rectangular boxes built in Wall 66. The S. E. part of these boxes consists of orthostatic blocks resting on the rock inside the wall and on the bottom course of the wall itself, formed by horizontal blocks placed lengthways. The box is closed by such blocks on three sides and open on the fourth, to the N. E. The inside of these blocks is well dressed while the outside is left rough. The N. W. box is of the same construction but better preserved. The S. W. part of the box is covered by a horizontal block placed across the top and the inside of this block, i. e., that turned down,



is well dressed, too, while the upper side is rough and unworked. Finally, an orthostatic block is placed across the box close to the N. E. end of the horizontal block. The purpose of these boxes is obscure. Possibly they formed a part of a latrine (cf. below, p. 213). The walls are not bonded to any of the adjoining walls.

Wall 68. (Room 93.)

Width: 1.05 m. Height: 2.25 m.

This wall is the best preserved specimen of a typical box-wall of Class C. The lowermost part of the mural face is rock-cut; then follow two courses of orthostates, a third course of horizontal blocks placed lengthways, a fourth course of orthostates, and a fifth course of horizontal blocks placed lengthways. Transverse blocks are inserted between every orthostate or between every second and third one.

The wall is bonded to Walls 71 and 72.

Wall 69. (Room 93.)

Width: 1.05 m. Height: 2.20 m.

The construction of this wall is identical with that of Wall 68. The S. E. end of the wall is less well preserved in that only three courses of blocks are left. The rock-cut part of the face is partly missing and substituted by a levelling substructure of horizontal blocks placed lengthways. About 2.10 m. from the S. E. end of the wall there was originally a doorway which later has been carefully blocked up with masonry of the same kind as the wall itself, but the joints are conspicuous in both faces of the wall. The wall is bonded to Wall 72.

Wall 70. (Room 92.)

Width: 1.10 m. Height: 1.55 m.

The construction of this wall is similar to that of the preceding walls. Only three courses of blocks are preserved and the S. E. end is almost entirely destroyed. The faces of the wall are not so regularly coursed as those of the preceding wall on account of the irregular slope of the rock. The wall is bonded to Walls 59 and 71 but not to the other adjoining walls.

Wall 71. (Rooms 92, 93.)

Width: 1.15 m. Height: 2.20 m.

The wall is of the same construction as that of the preceding walls. Its N. E. part is much destroyed. Two doorways open in the wall, one leading to Room 92 and the other to Room 93. The latter doorway has been blocked up with rubble. The wall is bonded to Walls 68 and 70.

Wall 72. (Rooms 92, 93.)

Width: 1.10 m. Height: 2.20 m.

This wall is of the same construction as the preceding. The faces of the wall display breaks in the courses of the blocks caused by the slope of the rock, which necessitated careful levelling if such breaks should be avoided. The wall is bonded to Walls 68 and 69.

Wall 73. (Room 53.)

Width: 0.75 m. Height: 0.50 m.

The wall is built of one course of facing and transverse orthostates, the facing blocks placed opposite each other in pairs, with transverse blocks inserted between every second pair of



Fig. 75. Vouni. The palace. Wall 183.



Fig. 76. Vouni. The palace. Doorway of Room 44 blocked up with rubble.

facing blocks. In the middle of the wall, two transverse blocks project out of the S. W. face. This projecting part probably formed the substructure for a supporting pillar of mud-bricks along the upper mud-brick wall. The wall is not bonded to any of the adjoining walls.

Wall 74. (Room 36.)

Width: 1.15 m. Height: 0.60 m.

This wall is built of facing orthostates with transverse blocks between each or every second of the facing blocks. In the N. E. face there is a levelling bottom course of horizontal blocks placed lengthways on the rock. This levelling course is missing in the S. W. face because the rock rises there. Only the S. E. part of the wall is founded on the rock; to the N. W., where the rock slopes rapidly, it is founded in the filling below the floor, but this part of the wall has been entirely destroyed from about the middle of its length. The wall is partly built across the filled-in opening of the well-shaped cistern in Room 35 (cf. p. 166). The wall is bonded to Wall 75 but not to Wall 182.

Wall 75. (Room 47.)

Width: 1.00 m. Height: 0.50 m.

This wall is of the same structural type as the preceding one. Apart from the transverse blocks at the ends of the wall there is only one such block used in the masonry, but this is explained by the shortness of the wall.

Wall 76. (Room 14.)

Width: 1.25 m. Height: 2.00 m.

The wall is of the same construction as those preceding. There is a doorway in the middle of the wall between Rooms 13 and 14. The part N. W. of the doorway is much destroyed. As was stated above, the S. W. shell of the demolished Wall 8 was built into this part of Wall 76 forming its N. E. face. The wall is built on a rock-cut elevation of the same kind as the other walls (e. g. Walls 9—11, etc.) in rooms which are partly cut in the rock. The top of this elevation is cut in step-shaped ledges. This fact indicates that at the time when Wall 8 was in use there was a staircase built on this rock elevation along the S. W. face of that

wall, leading to the upper story of Rooms 10—12 (cf. p. 162). Room 14 was thus originally a vestibule, separated by Wall 8 from Room 13 and entered from the outside through the door in Wall 15 and communicating with the palace rooms by the staircase. When the door in Wall 15 was blocked up (cf. pp. 117, 199) and the room consequently was no longer used as a vestibule, the staircase ceased to function. Wall 8 was then demolished, the staircase transformed into a new wall (Wall 76) and a doorway was opened in this wall, by which Room 14 communicated with Room 13. The wall is not bonded to any of the adjoining walls.

7. Double-faced shell wall of so-called hook-wall type.

These walls are built of alternating orthostates and horizontal blocks placed lengthways, in such a way that a horizontal block placed lengthways and an orthostate on top of that in the one face corresponds in the opposite face to an orthostate and a horizontal block placed lengthways on top of it. In section, the blocks of the wall thus form a series of hooks. The space between the blocks is filled with small stones, earth, and sometimes pieces of lime-mortar, which is also sometimes used in the joints between the blocks. The construction is a vertical variety of the box-walls.

Wall 77. (Room 32.)

Width: 0.76 m. Height: 0.75 m.

The orthostates in the opposite faces are of unequal height; the difference in height is levelled by layers of smaller stones and the use of horizontal blocks of unequal thickness; in the N. W. face there are two superimposed courses of horizontal blocks placed lengthways for on account of the difference in level of Rooms 30—31 and 32, the course of horizontal blocks on the rock in Room 32 is on a level with the lowermost of the superimposed horizontal blocks on top of the bottom course of orthostates in Room 31. The joints of the blocks in the N. W. face are not so well adjusted as in the other part of the wall and are therefore wedged with chips of stone and lime-mortar. In the middle of the wall, there is a doorway between Rooms 30 and 32, and at the N. E. end of the wall there is a staircase leading from Room 31 to Room 32. The wall is bonded to Wall 78 but not to any other of the adjoining walls.

Wall 78. (Room 32.)

Width: 0.80 m. Height: 0.60 m.

The wall is of the same construction as the preceding. In the middle of the wall, is a doorway between Rooms 29 and 32. In the part of the wall S. E. of this door, the joints are filled with lime-mortar which is not used in the part of the wall N. W. of the door.

8. Double-faced shell wall of orthostates only.

This type of wall is built of superimposed course of orthostatic blocks revetting an inner filling of limestone chips. The blocks are joined with lime-mortar.



Fig. 77. Vouni. The palace. Rooms 62 and 63 from the S. W. Walls 148 (foreground), 130 (left), 101 (right), and 149 (background).



Fig. 78. Vouni. The palace. Walls of Rooms 75—77, with the hearth of Room 75, in the foreground; walls of Rooms 96 and 97 in the background.

Walls 79—82. (Room 117.)

Width: 0.80—0.90 m. Height: 0.65—2.25 m.

Room 117 enclosed by these walls is partly cut in the rock being situated in a steep slope of the rock. The lower parts of the inner faces of the walls are therefore rock-cut. One to three courses of superimposed orthostatic blocks are preserved. In Wall 82 is a wide doorway leading into the room. It is flanked by projecting pieces of side walls. Wall 79 collapsed when subjected to the first winter-rains after the excavations, as a result of the not very solid construction of this type of wall, in which no courses of headers are used.

9. Wall built of a mixed construction of rubble and ashlar.

In some of the rubble walls, ashlar are occasionally used for strengthening purposes. Such walls are not included here but are described under their respective types of rubble walls (cf. below).

Wall 83 A—C. (Room 67.)

Width: 0.70 m. Height: 0.10—0.25 m.

The wall is formed by three parts (A, B, C) built at approximately right angles and enclosing Room 67. The wall is not well preserved. Parts of the wall are almost entirely destroyed and other parts project only slightly above the floor-level. The wall is built of orthostatic blocks revetting the exterior of a rubble wall. In the W. angle (between Walls 83 A and B) is a cemented water-conduit (cf. below) serving as outlet of water from the room.

Wall 84. (Room 66.)

Width: 0.75 m. Height: 0.45 m.

The wall is of similar construction to the preceding one, being built of orthostatic blocks as exterior revetment to a rubble wall. It is bonded to Wall 85.

Wall 85. (Room 71.) Width: 0.75 m. Height: 0.30 m.

This wall is of the same construction as the preceding.

Wall 86. (Room 71.) Width: 0.80 m. Height: 0.65 m.

The lower part of the wall is built of orthostatic blocks facing an inner filling of rubble, and on top of that are isodomic courses of rubble and horizontal blocks placed lengthways, alternating on the outside and the inside of the wall.

Wall 87. (Rooms 71, 72.) Width: 0.80 m. Height: 1.05 m.

This wall is of the same construction as the preceding.

Walls 88 A—B. (Room 132.) Width: 1.05 m. Height: 0.50 m.

These walls are of a similar construction to Walls 83 and 84 with orthostatic blocks facing the exterior of a rubble wall. Along the interior face of Wall 88 A and the other walls of Room 133 there is a platform of a single row of stone slabs as in Room 127 (cf. Wall 48).

Walls 89—91. (Room 104.)

Width: 0.50 m. (Wall 89); 0.50 m. (Wall 90); 0.45 m. (Wall 91).

Height: 0.55 m. (Wall 89); 0.50 m. (Wall 90); 0.45 m. (Wall 91).

These walls are partly built of rubble, partly of ashlar facing a rubble core. They are bonded to each other.

10. Narrow rubble wall of obliquely laid stones.

The stones are not large, sometimes not larger than a clenched fist, and are laid in two rows obliquely to each other so that they are wedged in. On top there is usually a levelling layer of small stones. Sometimes the corners are strengthened with ashlar blocks. No binding material is used.

Walls 92—101. (Rooms 74—79, 62.) Width: 0.40—0.50 m. Height: c. 0.10—0.30 m.

Of Wall 92 only a few stones close to Wall 147 are preserved, and its construction cannot therefore be ascertained, but it seems most probable that it resembled that of the other walls in the coherent complex of Rooms 74—80. It has extended to Wall 102 which is indicated by the fact that the lower part of its face towards Room 80 is rock-cut and this rock-cut face extends to Wall 102.

Wall 93 has been overbuilt and widened by Wall 142. Its N. E. face is aligned with that of Wall 142, but its S. W. face is hidden by the addition to that wall. The wall is bonded to Wall 98.

Wall 94 is bonded to Wall 98, but not to Wall 99.

Wall 95 is bonded to Wall 98. Its upper part has been demolished below the upper floor in Room 75—77 (cf. below).

Wall 96 is bonded to Walls 98 and 99. It has been strengthened with some large stones covering the whole width of the wall.



Fig. 79. Vouni. The palace. Walls 63 (left) and 64 A (right), from the N. E.

Wall 97 is bonded to Wall 100. The part S. E. of Wall 32 has been demolished.

Both the N. E. and S. W. ends of Wall 98 are destroyed. To the N. E. the wall has extended to Wall 92 and to the S. W. to Wall 97. It is bonded to Walls 93, 94, 95, and 96.

In Wall 99 a doorway opens to Room 75. On both sides of this doorway the wall is strengthened with ashlar blocks, which, however, have been almost entirely destroyed. To the N. E. the wall seems to have extended to the now missing but safely reconstructed N. E. wall of Room 80 (cf. below, Wall 102); this part of the wall, however, has been almost entirely destroyed at the erection of Wall 14. Only a small part at the S. W. end of this wall is preserved. The wall is bonded to Wall 96, but not to Wall 94.

Wall 100 is bonded to Wall 97. At the N. E. end of the wall a doorway opens to Room 74.

Wall 101 is in a bad state of preservation. It is covered by the second floor of Room 62 + 63. Originally it seems to have abutted against the brick wall 193.

11. Narrow rubble wall of stones laid opposite each other.
Walls 102—118. (Rooms 79, 29, 22, 19, 30, 1—5, 105—109.)

Width: 0.45—0.65 m. Height: c. 0.10—1.00 m.

The stones vary in size, but, as a rule, they are somewhat larger than those of Type 10. They are laid in two rows, approximately opposite each other. Sometimes two small stones

along the one edge of the wall correspond with one larger stone on the opposite edge. The corners and other parts of the wall are sometimes strengthened by ashlar blocks. No binding material is used.

Wall 102 is partly strengthened with ashlar blocks. Its N. E. part is destroyed. It originally extended to the N. E. wall of Room 80, which is entirely destroyed, but indicated by a cutting in the rock.

Wall 103 is built of rather small stones. The S. W. end is strengthened by ashlars, both orthostatic and horizontal blocks placed lengthways. In the lowermost course the stones are of larger size. The wall is bonded to Wall 159.

The faces of Walls 104 A—B are entirely coated with thick lime-mortar. The stones are rather large and meet in the centre of the wall. On the top is a layer of smaller stones.

Wall 105 is founded on the floor. The N. W. part of the wall towards the doorway, between Rooms 18 and 19, is strengthened by orthostatic blocks placed opposite each other, along the faces of the walls. The wall is not bonded to the adjoining Walls 106, 107.

Wall 106 is almost altogether destroyed. In the middle of the wall are two large blocks covering the whole width of the wall.

Wall 107 is built of rather large stones meeting in the middle. The corner of Room 54 is strengthened with ashlar blocks. A doorway opens in the wall between Rooms 18 and 31. The wall is bonded to Wall 108, but not to Walls 105 and 5.

Wall 108 is of the same construction as the preceding wall. At the S. E. end a doorway opens between Rooms 30 and 31 and the wall is there strengthened with an ashlar block.

Wall 109 is not a house-wall: it supports the filling of earth which forms a slightly sloping ramp leading to the main entrance of the palace.

Walls 110 A and B are bonded to each other but not to Wall 109. Walls 111 A—B are bonded to each other but not to Wall 109. Walls 111 C—E are to a great extent destroyed. The angles of the walls are strengthened with ashlar blocks.

Walls 112—118 form a coherent complex, enclosing Rooms 105—109. The construction of the walls resembles that of Wall 102, but some are somewhat wider than that. They are occasionally strengthened with facing ashlars in the same way as Wall 102. The walls are bonded to each other as far as it is possible to state, except Walls 115 and 116. Doorways open into Room 105 in Wall 118, into Room 106 at the S. W. end of Wall 117, and in Wall 116, into Room 109 in Wall 115 and an exterior doorway between Walls 112 and 113. To Room 107—108 a doorway probably opened in Wall 113, though this could not be ascertained on account of the inconsiderable height of the wall. At the exterior entrance to Room 106, there is a projecting piece of Wall 117 which seems to be a later addition, the original end of Wall 117 being marked by a transverse, orthostatic block at the point from whence the projecting wall starts.

12. Wide rubble wall of middle-sized stones.

Walls 110—125. (Rooms 7 A—B, 37—40.) Width: 0.85—1.20 m. Height: c. 0.10—1.00 m.

The walls are rather irregularly built of rubble kept together by earth-mortar. The stones

are generally rather small. There is no defined facing of the wall, though the stones along the edges are somewhat larger than those in the core.

On the outside of Wall 119 A there are buttress bases of large blocks of stone, embedded in a concrete of lime-mortar, forming a very solid structure, opposite Walls 50, 124, and 123.

Wall 119 B is a continuation of the preceding wall and of similar construction. Though the walls are continuous and there is no clear joint between them, there are some irregularities in the masonry, opposite Wall 121 giving the impression that Walls 119 A and B have been botched together at this point.

Wall 120 is bonded to the preceding wall. Its S. W. end, at the main entrance of the palace, has been strengthened with large rubble and stone blocks.

Only the S. W. part of Wall 121, between Rooms 36 and 47, is preserved above the floor. The other parts of the wall have been demolished to below the floor-level, and form a sub-structure for the staircase leading to Room 37 from Room 7 A. The wall is bonded to Wall 125.

Walls 122, 123, and 124 are bonded to Wall 125 and Wall 124 is bonded to Wall 119 A, too. Wall 124 is partly strengthened with orthostatic blocks in the faces.

Wall 125 is well built of small, rather sharp-edged stones mixed with pieces of Paradisotissa stone, and thus forms a sort of transitory type between walls of Types 12 and 13. The construction of the wall is, however, similar to that of the preceding. The wall is partly strengthened by ashlar blocks. Three doorways, one to each of Rooms 37, 38, and 39, open in the wall.

13. Wall of sharp-edged stones.

Walls 126—138. (Rooms 56, 55, 54, 46, 49, 33.)

Width: 0.70—1.05 m. Height: c. 0.10—1.20 m.

While all the walls of the preceding types are built of rounded rubble, the stones of the walls of this type are sharp-edged being chipped, waste stones from the quarries. Pieces of Paradisotissa stone occur not infrequently in these walls. The stones at the edges are somewhat larger than those in the core but there is no definite facing. The stones are embedded in filling of red mud-brick earth and the faces of the walls are covered with a thick coating of lime-mortar by which they were kept together.

Wall 126 is rather carelessly built of comparatively small, sharp-edged stones of the Vouni rock mixed with pieces of Paradisotissa stone. In the angle of Wall 127 the stones are somewhat larger. Room 56 is partly cut in the rock so that the lower part of the face of the wall is formed by cut rock. The wall has originally extended to the doorway between Rooms 56 and 57, but has been demolished close to the doorway, at the erection of Wall 35 which now flanks the doorway.

Wall 127 is bonded to the preceding wall and of the same construction, and the lower face of the wall towards Room 56 is formed by the cut rock. At the ends of the wall and occasionally in between there are stones of a larger size.



Fig. 80. Vouni. The palace. Walls 63 (left) and 64 A (right), from the East.

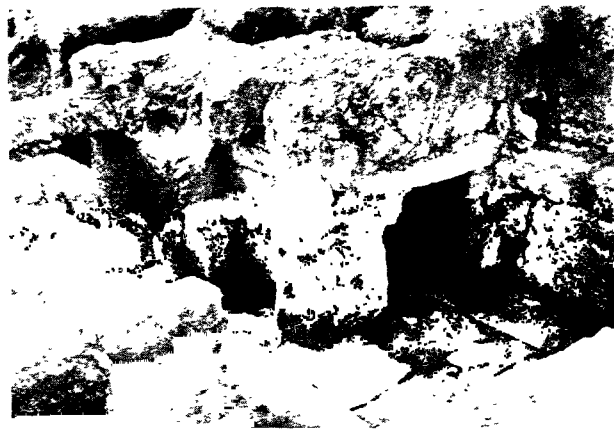

Fig. 81. Vouni. The palace. Walls 64 B (foreground) and 64 A (background), from the N. W.

Wall 128 is bonded to the preceding wall and of the same construction. As Room 55, too, is partly cut in the rock, this forms the lower part of the face of this wall, too. The wall is not bonded to Wall 130. A doorway opens in the wall between Rooms 55 and 56. The lower face of Wall 130 towards Room 55 is rock-cut as in the preceding walls. The wall has been substituted for Wall 129 which has almost altogether been demolished: only a few stones of the bottom course are left, near the east corner of the room. The stones are only preserved up to the cemented floor of the room and the floor is laid against this preserved part of Wall 129, and does not continue to Wall 130 which runs slightly inside Wall 129. Further to the S. W., where no stones of Wall 129 are preserved, the edge of the cement floor ends in line with the preserved part of that wall and from this edge, the floor consists only of the cut rock. Wall 129, however, did not run parallel with Wall 130: the preserved part of the wall and the edge of the floor form a line which runs slightly S. W. of Wall 130 so that the lines of the walls cut each other, at the present staircase leading from Room 55 to Room 64. S. W. of this staircase the line of Wall 129 coincides with the line of the rock-cut face of the room, while Wall 130 projects somewhat inside the rock-cut face overhanging it. It is thus evident that the original S. E. wall of Room 55 ran obliquely and that the adjusted, rebuilt wall aimed at giving the room a rectangular shape by cutting the rock somewhat inside the original wall N. E. of the staircase and hanging the wall somewhat over the rock-cut face S. W. of the staircase. There are traces of a staircase connected with Wall 129, S. W. of the staircase of Wall 130 (cf. p. 157).

Wall 131 is not bonded to Wall 130 which abuts against the wall with a transverse, orthostatic block, but is bonded to the preserved part of Wall 129. A doorway opens in the wall between Rooms 54 and 55.

Wall 132 is of the same construction as the preceding wall and bonded to it.

The S. E. face of Wall 133 is revetted with orthostatic blocks forming a continuation of the ashlar blocks of Wall 56. A doorway opens in the wall between Rooms 46 and 47. The part of the wall N. E. of this doorway is strengthened with ashlar blocks.



Fig. 82. Vouni. The palace. The roof of the fire-rooms of the sudatory.



Fig. 83. Vouni. The palace. Interior of Room 85 of the hot bath with outlet for the drainage channel in Wall 58.

Walls 134 and 135 are almost altogether destroyed. They are bonded to Wall 136. Doorways open in the middle of the walls between Rooms 49 and 50 and Rooms 48 and 49 respectively.

Wall 136 is aligned with the S. E. rock-cut edge of Rooms 29 and 32. It is partly strengthened with ashlar of Vouni rock at the edges, and occasional Paradisotissa blocks are also inserted in the masonry. The ashlar are joined with lime-mortar. The wall is bonded to Walls 134, 135, and 137 but not to Wall 78.

The N. E. face of Wall 137, S. E. of the doorway, runs 0.20 m. inside the edge of the floor of Room 33. Between the floor and the face of the wall is a groove filled with lime-mortar. This seems to indicate that the wall was provided with a wooden revetment there, a unique feature in the masonry of the palace walls. A similar construction is characteristic of the altar in Room 117 (cf. below). In the middle of the wall, there is a doorway through which there is communication between Rooms 33 and 31—32 by means of a staircase built along the S. W. face of the wall (cf. p. 159). The N. W. part of the wall passes over into the ashlar wall 5 (cf. p. 113). The S. W. part is bonded to Wall 138 which is an angular continuation of Wall 137 and of the same construction.

14. Wall of rubble with edge stones.

Walls 139—178. (Rooms 98, 76, 64, 69, 59—63, 84, 57, 28, 23, 16, 118, 121, 125, 122, 123, 133—135.)

Width: 0.55—1.10 m. Height: c. 0.10—1.30 m.

The walls are built of an inner filling of earth and small stones, with stones of a larger size along the edges. In structure, the walls are connected with those of Type 11; on account

of their inconsiderable width, the stones usually meet in the middle, or there is only a narrow space of filling in between, but if a narrow wall of that type was to be made wider, it naturally became a wall of Type 14.

Walls 139, 140, and 141 form a coherent complex bonded to each other, but not to Wall 21. The stones used in these walls are of medium size. Near the S. W. end of Wall 140 an ashlar block is inserted in the wall. In Wall 141, there is a doorway between Rooms 98 and 100. The door-jambes are formed by transverse, orthostatic blocks.

Wall 142 is built on top of Wall 93 and revets its S. W. face. Along the wall, in Room 76, there is a rectangular platform of rubble. At the S. E. end of this platform is a sink walled in (cf. p. 171; Fig. 103).

Wall 143 is built as a continuation of Wall 97, but is not bonded to it. From its N. W. end, a short piece of wall projects to the S. W. at right angles to the wall. This projection is wider than the wall itself, and is built on top of a rock-cut elevation, but is almost altogether destroyed. Close by the N. E. face of the wall is a square base, built of rubble.

Wall 144 is built of medium-sized rubble as edge stones. It is not bonded to Wall 86.

Walls 145 and 146 are founded in the debris and not on the rock. The walls are built in the same technique as the preceding wall and are bonded to each other, but not to Wall 86. At the S. W. end of Wall 145 there is a doorway leading to Room 69.

Wall 147 is the widest wall of this mural type and at the same time its most typical representative, with large edge stones and a rather loosely built core of small stones and earth filling. In the N. E. part, there is a hole for a drainage groove through the wall (cf. p. 171). This hole is built of square stones and is rectangular in shape. It can be seen that the hole has been cut in the wall after its erection: the stones around the hole are smaller and laid in a more irregular way than in the remaining part of the wall, indicating that a part of the hole opened for the water-conduit has been blocked up there.

Wall 148 is somewhat narrower than the previous one but of similar construction. The walls are, however, not bonded to each other. An examination of the faces of the wall close to Wall 147 shows that there was originally a doorway there, about 1.15 m. wide, which was later blocked up with smaller rubble. This blocked up part is not properly bonded to Wall 147, and botched up with the remaining part of Wall 148. This is bonded to Wall 130.

Walls 149, 150, 151, and 152 form a coherent complex of walls built as substructures for a staircase leading to the upper story of the palace (cf. pp. 162 f.). The edge stones are smaller than those of Wall 147. The walls are bonded to each other and Wall 149 is bonded to Wall 130 but not to Wall 132. The walls are strengthened with occasional ashlar in the corners and at the ends.

Walls 153 and 154 are of the same construction as Walls 144 ff. They are bonded to each other. Wall 153 abuts against the ashlar wall 50. At the N. E. end of Wall 154, a doorway opens on to Room 84.

Wall 155 revets the exterior face of Wall 73. Edge stones of the same size as in Wall 147 occur only in the exterior face of the wall; the interior is piled up of small stones and earth in an irregular way. The wall is founded on the upper floor of Room 57.



Fig. 84. Vouni. The palace. Walls of Rooms 21—23 from the N. E.

Walls 156, 157, 158, and 159 form a coherent complex of walls bonded to each other. They are built of rather large stones in the faces and the stones have rather sharp edges, but are not of the chipped, sharp-edged type used in walls of Type 13. The walls thus form an intermediate type between Types 13 and 14. Rooms 27 and 28, enclosed by the walls, are partly cut in the rock and the walls are built aligned with these rock-cut faces. At the S. W. end of Wall 156, there is a doorway with a flight of steps between Rooms 27 and 57, and in the middle of Wall 159 another doorway opens on to Room 28 from the lowermost steps of the staircase built along the exterior face of the wall, and leading up to Room 50 from the lower level of Room 29.

The construction of Wall 160 resembles that of Wall 147 with large edge stones in the faces. At the N. E. end of the wall, a doorway opens on to Room 23 and the wall is there strengthened with facing, orthostatic blocks. The interior of the wall is entirely coated with a thick layer of lime-mortar in the same way as Wall 104. The wall abuts against the ashlar wall 57.

Wall 161 is of the same construction as the previous wall. It is bonded to Wall 104, but not to Wall 181.

Walls 162 and 163 are bonded to each other and abut against the ashlar walls 5 and 17. The walls are of a solid construction with regularly laid faces which to some extent are strengthened with ashlar blocks. In the middle of Wall 162, a wide doorway opens on to Room 16.

Wall 164 is a freely standing wall, running parallel with Wall 81 and screening off a passage along the N. W. wall of Room 117. The stones are of a rather large size.

Walls 165, 166, 167, and 168 are badly preserved; some parts are entirely missing and of others only the bottom course of rubble is preserved. Walls 165 and 166 are bonded to each other. Wall 168 is oblique and cuts off a part of the N. E. corner of Wall 166, which shows that it was built later than that. It is bonded to Wall 167 which abuts against Wall 169.

Wall 169 A is somewhat better preserved. Its N. E. end is cut off by an oblique piece of wall (169 B) running parallel with Wall 168. The outside of this piece of wall is partly revetted with cut blocks facing the staircase leading up to Room 122. At the S. W. end of the wall is a rock-cut staircase leading up to a doorway between Rooms 121 and 122, the latter room being on a lower level than the former.

The S. E. part of Wall 170, along Room 122, is entirely destroyed. Room 122, however, is cut in the rock and it can therefore be safely reconstructed, on the evidence of the vertically cut rock wall. The N. W. part of the wall, along Room 123, is better preserved. At the S. corner of this room, the wall makes an angular turn and then proceeds in the same direction as before. The wall is not bonded to Wall 184, but at the junction of the two walls there is a conspicuous break. As will be shown below, p. 201, Wall 170 originally made an angular turn to the N. E. and was bonded to Wall 171, as shown by the analytical plan, Fig. 119, p. 189. This corner of the wall was destroyed at the erection of Wall 184.

Wall 172 is almost entirely destroyed, but can be safely reconstructed from the small parts preserved at both the S. W. and N. E. ends. It is bonded to Wall 173.

The S. E. end of Wall 173, close to the staircase entrance of Room 100, is strengthened with ashlar blocks. The wall is bonded to Wall 172, but not to the ashlar walls 48 and 49.

Walls 174, 175, 176, 177, and 178 form a coherent complex of walls bonded to each other. In the middle of Wall 178, a doorway opens on to Room 134. Walls 176 A—C enclose a small recess, Room 135, and a narrow doorway in Wall 175 opens on to this recess from Room 134. The walls are partly destroyed.

15. Rubble wall of irregular construction.

Walls 179—189. (Rooms 65, 20, 34, 43, 124, 110.)

Width: 0.40—1.00 m. Height: c. 0.10—2.05 m.

Walls 183—187 are wide walls, the others are narrow.

Walls 181 and 182 are built of very small stones. The N. E. angular end of Wall 181 is strengthened with cut stones. The walls are founded on the floor of respective rooms.

Walls 179 and 180 are bonded to each other and Wall 180 abuts against Wall 35. The walls are built of small and large stones in irregular construction.

Wall 183 is also built of large and small stones without any distinct order. It is founded on the floor of Room 43-44 and abuts against the ashlar walls 52 and 53.

Walls 184, 185, 186, and 187 form a coherent complex. The walls are built of small and large stones in irregular construction. At the N. E. end of Wall 186, there are some cut blocks. Wall 184 is not bonded to Wall 170; the corner between Walls 185 and 186 is miss-



Fig. 85. Vouni. The palace. S. W. face of Wall 191.

ing. At the S. E. end of Wall 187, a rock-cut staircase leads up to a doorway opening on to Room 124.

Walls 188 and 189 are bonded to each other. The S. W. end of Wall 189 is destroyed so that it cannot be ascertained if the wall was bonded to Wall 115. The walls are built in an irregular construction of small and large rubble, and are partly strengthened with cut, facing blocks.

16. Terrace wall of rubble.

There is only one wall of this type: viz. Wall 190, supporting the terrace in front of the palace temenos (Rooms 121—129) and the N. W. cult-chapel (Rooms 132—135). The terrace is formed by a filling of earth and gravel, and the wall is built in a solid construction with a carefully laid exterior face of large rubble in distinct courses.

Mud-brick walls.

The stone walls formed substructures for the upper walls of mud-bricks. Only three walls are entirely built of mud-brick: Walls 191—193. Wall 193 is almost entirely destroyed and only preserved below the upper floor of Room 62 + 63 (cf. pp. 149 and 195). It is founded in a groove cut in the rock. Walls 191 and 192 are preserved up to a height of 1.65 m. The walls rest on a levelling bottom layer of chips of stone. They are coated with lime-mortar.

The construction of the mud-brick walls can best be studied in this preserved wall and the collapsed, upper walls in Room 88. The mud-bricks are of two different shapes: Types A and B. Type A measures 0.48 × 0.225 × 0.16 m. and Type B 0.46 × 0.46 × 0.14 m. Type A

is thus rectangular and Type B square in shape. These two types have been used in such a construction, that on a course of four bricks of Type A placed lengthways and side by side across the width of the wall, is laid a course of bricks of Type B in such way that two bricks cover the width of the wall. Probably the third course consisted of two bricks of Type A along the faces of the wall with one brick of Type B between them, so that the wall was properly joined, but unfortunately this could not be ascertained. The joints of the red bricks were filled with red earth and the whitish bricks with white earth. The faces of all the brick-walls were probably coated with lime-mortar, as the preserved wall 191. It is obvious that the width of two rectangular bricks of Type A placed lengthways with an interstice of 1 cm. for the joint between them corresponds to the width of one square brick of Type B. Furthermore, the width of a brick-wall constructed in this way, the joints between the bricks and the coating of the faces included, would be about 0.95 m. which corresponds to the normal width of the stone foundations.

Gates and doors.

The construction of the gates and doors can be studied on the preserved remains, especially in Rooms 7 B, 44, 45, 100.

The thresholds seem, as a rule, to have been of wood resting on a substructure of stone slabs or rubble, or in one case (Room 16) of a rock-cut elevation. At two of the exterior gates (Rooms 100 and 7 B), however, the thresholds are formed by stone slabs without any wooden covering structure, which can be seen from the fact that in the gate of Room 100 there are holes for the bolts of the door in the slabs of the threshold. The wood has naturally decayed and, as a rule, without leaving any traces. In one case, however, the wood structure could be proved, viz. in Room 45: in the threshold-structure of rubble and lime-mortar, there are clear impressions of the wooden planks of the threshold; this had however been nailed on to two cross pieces of wood, of which there are wedge-shaped impressions in the substructure.

The door-jambs, too, have been of wood. They were sunk in square cavities (Room 100), or rested on raised, square bases (Rooms 7 B, 53) at the exterior gates and the wide doorways of the palace rooms. In the doors of the other rooms, the door-jambs seem to have rested direct on the wooden thresholds. Impressions of the wooden planks of the door-jambs are visible in the doorways of Rooms 44 and 45, where the walls flanking the doorway end with a concrete of small stones and lime-mortar which has coated the door-jambs.

The lintels, as well as the doors themselves, have naturally been of wood.

In one case (Room 100) it was possible to state that the doors swung on pivots on the evidence of pivot holes carved in the stone slabs of the threshold. As no door hinges of metal were found, it is to be supposed that the doors, as a rule, swung on pivots though this no longer can be proved, as the pivot holes were carved in the wooden thresholds.

The wide gates were closed by double doors and then the one half of the door was fixed by means of bolts, as can be seen from holes for such bolts bored in the stone slabs of the thresholds of Room 100.



Fig. 86. Vouni. The palace. Entrance into Room 45 with impressions of the wooden door-posts.



Fig. 87. Vouni. The palace. Floor of Room 51; Walls 1 and 3 in the background.

Floors.

The floors are of the following structural types:

1. Floor of levelled rock, with or without a thin layer of lime-cement levelling the irregularities of the rock.

Floors of this type are represented in Rooms 10, 11, 12, 16, 27, 28 (lower floor), 85, 98, 103, 117, 121, 123, 124, 125, 126, and 128.

In Rooms 11 and 12 the floor is rock-cut without any levelling layer of lime-cement. The floor slopes towards the N. W. Along the wall, there are holes cut in the floor. The holes are conical in shape with the pointed end down and seem to have been made for the purpose of keeping storage vessels with pointed base, such as Nos. 246, 248, 249, 265, 266—268, 297, 464, 465, 570 (see Obj. Reg.) in their place. There are traces of fire on the floor.

The floor of Room 10 has a covering layer of thin lime-cement on the carefully levelled rock floor, especially in the N. W. parts of the room. No holes for storage vessels are cut in the rock. As in Rooms 11 and 12 there are traces of fire on the floor.

In Room 16 the floor is roughly rock-cut without covering lime-cement. It slopes to the gate in the N. W. wall of the room.

The floor of Room 27 is roughly rock-cut as that of Room 16 and there are unlevelled traces of the cutting visible. The floor slopes towards the middle of the room and is blackened by a thick layer of carbonized matter which accumulated in the N. corner of the room.

In Room 28 there are two floors. The upper floor is of Type 5 (cf. below); the lower floor

consists of the roughly levelled rock. That this has once served as a floor is evident from the fact that here is a groove cut in the rock which once led off the water to an outlet through Wall 12. This outlet was later blocked up when the staircase from Room 25 was built at this place (cf. p. 158), and the upper floor of lime-cement covering the groove was laid. Another indication supporting this is given by the fact that there is a cemented water-conduit covered by the cement floor, and running from the basin in Wall 158 to the cistern in Room 19. Water-conduits of this type were only used *above* the floors (cf. pp. 163, 167).

The floor of Room 85 is roughly rock-cut and slopes to the exit in the N. E. wall of the room by stepped ledges.

Room 98 has a roughly rock-cut floor as those of Rooms 16 and 27. There are no traces of fire on the floor and some of its irregularities were filled with earth.

In Room 103 the floor seems to have consisted of roughly levelled rock. In any case there were no remains left of a floor of another type.

The floor of Room 117 consists of carefully levelled rock without any covering coat of lime-cement. In the E. corner of the room the floor shows traces of fire.

Rooms 125, 126, and 128 have a rock-cut floor with a thin covering coat of lime-cement, which to a great extent is worn off and damaged. The floor of Room 125 slopes to the N. E. towards the open front side. In the E. corner of Room 126, where the rock slopes there is a filling of earth below the cement coat. On the floors of both Rooms 125 and 128, there are traces of fire.

In Rooms 121, 123, and 124 the rock is only roughly levelled, or entirely unworked. The irregularities seem to have been filled with hard-packed earth. The floor-level follows the natural slope of the rock.

2. F L O O R O F L E V E L L E D R O C K A N D L I M E - C O N C R E T E .

Floors of this type are represented in Rooms 13, 14, 86, 87, 88, 92 (lower floor), 93, and 101.

In Rooms 13 and 14 the rock is not much levelled, and the irregularities are filled with white lime-concrete; in Room 13 this concrete is thickest in the S. E. part of the room, where it fills a natural cavity in the rock; in Room 14 the thickest filling is found in a cavity in the W. corner of the room.

The floors of Rooms 86—88 are rock-cut in the S. W. parts of the rooms and consist of a filling of white buff, occasionally reddish lime-concrete in the N. E. parts where the rock slopes.

The lower floor of Room 92 consists of levelled rock and a filling of white lime-concrete mixed with gravel. This filling covers a part of the levelled rock, too. Later on this floor was covered with a floor of Type 5 (cf. p. 152).

The concrete of the floor of Room 93 resembles the lower floor of Room 92; it is mixed with gravel, and occasionally small stones, and covers most of the levelled rock below.

In Room 101 the S. W. part of the floor seems only to have consisted of levelled rock.

In the W. corner, however, pieces of lime-concrete were found which show that the irregularities in the rock were filled with such concrete.

3. Floor of white lime-marl.

Rooms 34 + 35 (upper floor), 57 (lower floor), 60—63, and 64 (lower-most and middle floors), have floors of this type.

On the lower floor of Room 34 + 35 (Type 5) there is an upper, thick floor of white lime-marl of rather hard consistency. This upper floor covers the mouth of the cistern there. The lower floor is cut through by Wall 74; the upper floor abuts against this wall, and Wall 182 is founded on the upper floor.

The lower floor in Room 57 is of this type and covers the irregularities of the roughly cut rock. The floor is cut through by Wall 34 and continues S. W. of this wall where it is preserved in patches.

In Rooms 59—63 there are two floors, the one on top of the other, both of white lime-marl. The lower floor is thin and of a soft consistency, levelling the irregularities of the rock. The upper floor is thicker and of harder consistency. The lower floor is cut through by Wall 147.

In Room 64 there are three floors, the one on top of the other. The upper floor is of Type 4 (cf. below). The lowermost floor is of a grey lime-marl covering the irregularities in the levelled rock. Below the two uppermost steps of the staircase, leading from Room 55, there is a stepped ledge of blue-grey lime-cement laid on the lower floor, and abutting against the middle step of the staircase in the doorway and covered by the middle floor of the room. This middle floor is made of white lime-marl.

4. Floor of red lime-marl.

Floors of this type are represented in Rooms 7 A + B, 57 (upper floor), 64 (upper floor), 66 (upper floor), 67, 68, 69, 81—82, 95, 96, 97, 104—110, 113, 114, 122, 127, 129, 133, 134, and 135.

The floor of Room 7 A + B is made of a red lime-marl of hard consistency. It is very thick and has proved to be of a great elasticity: in spite of considerable sinkings, especially in the northern parts, and cracks caused by these sinkings, the floor forms a continuous surface. Below the floor is a thick filling of earth covering the levelled rock.

The upper floor of Room 57 consists of a substructure of almost white lime-marl covered by red lime-marl of a softer consistency than that of Room 7 A + B. The floor abuts against Walls 34 and 73 and Wall 155 is founded on the floor.

The upper floor of Room 64 is made of a red lime-marl of softer consistency and is covered by a coat of white lime.

In Rooms 66 (upper floor), 67, 68, and 69 the floor is of the same hard consistency as in Room 7 A ÷ B and is covered by a similar coat to that of the floor in Room 64. The upper floor of Room 66 is much worn and the surface is uneven. The floor slopes to the West, towards the doorway in Wall 13. Below the floors are fillings of earth and waste material (cf. Section XXVII, p. 186).

The floor of the S. E. courtyard consisted to a great extent of hard-packed earth, at least partly covered with reddish lime-marl. This is especially preserved in the S. W. and S. E. parts of the courtyard (Room 81 + 82). In its N. E. part (Room 83), where the rock slopes steeply, there is a filling of earth resting on the rock below the floor and the floor-level is there only marked by rammed earth (cf. p. 153). The rock has here been quarried for building-stones in the same way as below the floor of Rooms 66 and 69 (cf. Stratification, pp. 178, 186).

In Rooms 95, 96, and 97 there are remains of a floor of red lime-marl along the walls of the rooms, but some parts of the roughly levelled rock are above the level of these patches of lime-marl. It is therefore evident that the lime-marl was only used as a filling of the cavities in the rock floor.

The floors of Rooms 104—110 are all of the same structure; the red lime-marl of the floor in Room 110 is, however, of a softer consistency than in the other rooms. In the middle of the floor of Room 104 and all over the floor of Room 110, there were traces of fire. In the S. part of Room 107 + 108, the floor rests on the levelled rock but in the remaining part of the room on top of a large cavity filled with earth. This pit extends partly below the floors of Rooms 109 and 110, too. The floor in Room 107 + 108 has sunk along the edges of the cavity. Between these rooms there is a narrow groove in the floor, and three circular holes, measuring about 0.22 m. in diameter, at a distance of 1.25—1.50 m. from each other and the adjoining walls divide the groove into three parts. It is to be supposed that this groove marks the existence once of a wooden partition separating the two rooms with supporting, wooden posts in the holes.

The floors of Rooms 113 and 114 consist of the levelled rock with filling of hard, red lime-marl in the cavities, and in the E. part of Room 114, where the rock slopes. In the latter room there are traces of fire on the floor.

In Rooms 122, 127, and 129, there are floors of a similar structure. In Room 122 the greater part of the floor consists of levelled rock; only to the E. where the rock slopes there is a filling of hard, red lime-marl. The floor of Room 127 is entirely covered with red lime-marl. In Room 129 there is a filling of white rock material below the floor in parts where the rock slopes. On the floor of this room there are traces of fire. The floor merges into that of the road along its open front without any line of demarcation (cf. pp. 153, 200).

Rooms 133 and 134 have floors of the same structure as those of the preceding rooms. In Room 132 there is a layer of sterile, red earth on the rock, above that a filling of carbonized matter and debris containing fragments of waste *ex votis* (cf. p. 280), and on top of this filling is a substructure of rubble, on which the floor was laid. This is now missing but was most probably of the same structure as those of Rooms 133 and 134.

5. Floor of thick, blue-grey lime-cement with a coat of white plaster.

This type of floor is commonest in the palace rooms. It is represented in Rooms 17—23, 25, 26, 28 (upper floor), 29—33, 34+35 (lower floor), 36—40, 42—56, 60, 73, 74, 76, and 92 (upper floor).

The floors of Rooms 17—20, 25, and 26 are continuous and seem to have been cast in one piece. The floors are well preserved with exception of damaged pieces in the S. corner of Room 17 and along the staircase in the same room. The floors abut against the walls of the rooms except Walls 105 and 181 which are founded on the floor. In Rooms 17 and 18, the floor declines rather steeply to the doorway in Wall 17, forming a sloping ramp.

The floors of Rooms 21—23 are made of an unusually hard lime-cement and slope towards the outlets in Wall 57 (cf. p. 172).

In Room 28 the upper floor of lime-cement is not grey-blue but rather buff in colour. It slopes towards the doorway in Wall 12.

The floor of Room 29 has a thin, finishing coat of white lime of an unusually fine and hard consistency. The floor has sunk in the N. W. corner of the room above the water-conduit passing below the floor (cf. p. 167). It is well preserved with the exception of a piece not far from the cistern in this room.

In Rooms 30 and 31 the floors are of the same structure as in Rooms 17 ff. The floor of Room 30 is damaged in the corner and in the middle of the room, above a water-conduit below the floor (cf. pp. 167 f.). Traces of fire are visible on the floor. In Room 31 two repairs of the floor can be observed: one in the W. corner, close by the doorway between this room and Room 18, and another one along the staircase leading up to Room 32. The damaged floor in these parts of the room has been mended with patches of lime-cement of finer consistency than that used in the original floor.

The floor of Room 32 is rather thin and the cement is of a softer consistency. Large pieces are torn off. Below this cement cover is a substructure of red cement. The floor is damaged along the staircase leading up to Room 33 and at the doorway to Room 30.

Only the half of the floor of Room 33 is preserved. The cement is buff in colour.

The floors of the rooms around the central court (Rooms 34+35 [lower floor]—40, 42—46, 48—56) and that of the court itself (Room 47) are in general of the same structure and differ mainly in the state of preservation. As a rule, the floors are made of a thick, blue-grey cement, rather coarse, and resting on a substructure of reddish cement. They were covered with a finishing coat of fine lime which often has been worn off.

The floors of Rooms 36—40 are almost altogether missing, owing to the fact that the walls of the rooms were destroyed down to the floor-level, or even below it. Below the floors there is a thick filling of earth (cf. p. 180) forming a levelling terrace on the steeply sloping rock.

The floor of Room 40 slopes toward the outlet of the water-conduit leading to Room 85 along Wall 51. Close to this wall, there is a circular part with the finishing coat well pre-

served. Probably a vessel of metal or wood which was once placed there prevented the coat from being worn off as in other parts of the floor.

Similar circular pieces are preserved in the floor of Room 42, along Wall 51 and in the S. corner. The floor of this room is well preserved and slopes to the W. towards the outlet of the water-conduit which is built into Wall 50, and leads to Room 85.

The floors of Rooms 43 + 44 and 45 resemble each other; in Room 45 the finishing coat of fine lime is better preserved, though even there some parts are worn off. Close to Wall 50 part of the floors in both the rooms have been repaired with a cement of darker colour. Wall 183 is founded on the floor of Room 43 + 44.

A similar repair is found in the middle of the floor of Room 46. The rest of the floor is well preserved. The staircase leading up to Room 60 is founded on the floor which abuts against the steps of the doorway to the S. W. courtyard (Rooms 81—83). The floor also abuts against the walls of the room, as always where nothing else is stated.

The finishing coat of the floor of the central court (Room 47) is worn off and the blue-grey cement is visible. In the N. part of the floor the cement is missing within an area bounded by straight edges around the mouth of the bottle-shaped cistern. It seems therefore that the cement has been purposely removed for a repair of the floor, which they were not able to finish before the palace was destroyed. On top of the filled-in basin cistern in the middle of the court, (cf. pp. 184, 191) the floor consists of white lime-marl without a covering stratum of cement.

All the floors of Rooms 48—56 consist of the same blue-grey, coarse lime-cement on a substructure of reddish cement as in the preceding rooms, but there is no substructure of red cement in Room 53, indicating that the floor of Room 53 was not laid at the same time as the floors of the other rooms, but on a later occasion. The floors are slightly damaged in the doorway, but for the rest they are well preserved. The floor of Room 51 has a well preserved finishing coat of thin and fine lime.

Room 60 has a well preserved floor of hard, blue-grey cement covered with a rather thick, finishing coat. It slopes towards the staircase.

The floors of Rooms 73, 74, and 76 are of the same type as that of Room 60. The cement is so hard that it has better resisted destruction, than the walls of these rooms which are sometimes destroyed below the floor-level.

The floor of Room 73 slopes slightly towards the doorway to Room 76, and the floor of this room slopes towards the outlet of the water-conduit built into Wall 30.

In Room 92 the upper floor consists of blue-grey lime-cement of rather soft consistency. This floor was laid on top of the lower floor when that began to be worn. The upper floor, too, is much worn.

6. Floor of stone slabs.

Only a single floor, viz. in Room 41, is of this type. The floor consists of rather large, rectangular limestone slabs on which there are traces of fire. The reason why this unique type of floor was used in this room seems to lie in the fact that the room was used as a place from

where fuel was brought into the fire-rooms of the sudatory, in the S. E. wall of the room. It is therefore natural that the floor was subject to much wear and the action of fire, which a floor of stone slabs resists better than lime-cement of a rather soft consistency. The floor abuts against Walls 64 A and 65, while Wall 64 B is founded on the floor.

7. Earth floor.

Floors of rammed earth were found in Rooms 66 (lower floor) 75, 77, and 84, and in the N. E. part of the S. E. court (Room 83). Below the floors are fillings of earth of different kind (cf. pp. 177 ff.; 185 f.) levelling the irregularities of the rock. In Room 75+77 there was an upper floor of rammed earth mixed with lime which is only partly preserved on top of Wall 95, which shows that this wall was no longer used at the time of the upper floor. Earth floors were thus used in courts (Rooms 66, 83) and in rooms where fires were lit: Rooms 75 and 77 were the kitchens of the palace (cf. p. 208) and Room 84 was used for heating water for the hot bath (cf. p. 228).

In some rooms, e. g. Rooms 71, 72, 94, no floor was preserved.

The roads outside the palace are usually cut in the rock without any other levelling material than earth, gravel, and lime stuff in the irregularities. Only where the road widens into small, open places, or on account of the steep slope of the rock, was terracing necessary, and the roads are covered with a pavement of different structure. Thus the road running along the N. E. exterior wall of the palace has a pavement of red lime-earth, on a filling of earth, gravel, and small stones in its S. E. part, where the rock slopes. To the N. W., the road widens to a small, open space which later was cut off by Walls 119 B—120 and Room 7 A+B (cf. p. 192), and the rock floor of this space was coated with thin lime-cement.

A similar pavement of red lime-marl is found on the road running along the N. E. long side of the main temenos (Rooms 121—129). Below the pavement, there is a very deep filling of earth and gravel, as the rock slopes very steeply here; this filling is supported by the terrace wall 190.

RooFs.

The roofs have not been covered by terracotta tiles: for not a single fragment of such was found. The roofing was constructed in such a way, that a matting of reeds ceiled with earth and lime was laid on horizontal, wooden beams. Many impressions of reeds on pieces of the preserved roofing, found chiefly on the floor of Room 53, prove this with certainty.

As there is no spring on Vouni it was necessary to collect a maximum quantity of water during the rainy season. The roofs were used for this purpose and the water collected on the roofs was carried off by gutters into a number of cisterns in different parts of the palace. On account of this, the roof cannot have been absolutely horizontal, but must have had a slight slope. On the other hand, the fact, that the roofs were used for an effective and necessary collection of rain-water makes it most improbable that they were saddle-shaped, because some of the cisterns are so placed, that in such a case, only half of the water falling on the roof could be collected in some parts of the palace. Thus the cistern receiving the water from

the roofs of Rooms 10—14 is found in Room 19, the water from the roofs of Rooms 37—40 was carried to the cistern in the central court (Room 47), and the water from the roofs of Rooms 85—98 was collected in the cistern of the S. W. courtyard (Rooms 81—83). In all these cases and others too, as can be seen from Plan IX, only half of the water falling on the roofs could have been collected in the cisterns, if the roofs were saddle-shaped. The roofs have therefore sloped in one direction only, and the question is how great was the inclination, if the roofs sloped slightly so that they looked almost horizontal, or steeply so that they were desk-shaped. The roofing material seems to deny the latter alternative: the steep slope would have given the water an unnecessarily great force which would have damaged the packing of earth and lime. It is naturally very hazardous to calculate the inclination, and such a calculation must be hypothetical. If, however, we suppose that the height of the rooms covered by the same roof was approximately constant, e. g. Rooms 31 and 32, we can calculate that the inclination was about 1:5, having regard to the fact that the floor-level of Room 31 is about 0.60 m. below that of Room 32. Such a slight inclination seems most probable, and roofs of this type, either sloping slightly or horizontal, have always been used in the architecture of this and adjoining regions of the Near East, and are still used in their modern architecture.

The roofs of the palace therefore seem to have been of this type. It is only possible to take into consideration, that the roofing has been of another shape in a single place, viz., in Rooms 51—53. It is possible that the roof covering these rooms formed a watershed, so that the water from the N. W. part of the roof was carried off by the gutters in Rooms 18 and 28 to the cistern in Room 19, and from the S. E. part of the roof to the cistern in Room 61 during the 1st and 2nd building-periods and to the cistern in the central court during the 3rd and 4th building-periods (cf. p. 167). The existence of a saddle-shaped roof is therefore *possible* in this place, but on the other hand, it must be pointed out that a roof sloping slightly in both directions would make possible the same collection of the water and, finally, it is not at all necessary to suppose that the roof of these rooms formed a watershed: equally, the roof may have sloped only to the N. W. and in such a case all the water collected on the roof was carried to the cistern in Room 29. In any case it seems probable that it was a lantern roof in order to admit sufficient light and this is supported by the fact that the walls of the rooms in question are considerably wider than those of the adjoining rooms (cf. p. 206).

C o l u m n s.

Columns were used to support the roof of the peristyle of the central court and of the walls with open fronts.

The preserved fragments of the columns are of hard limestone of the Vouni rock. The stylobate of the peristyle consists of well dressed, rectangular slabs of Paradisotissa limestone. These slabs rest on a substructure of chipped stones. A great number of these slabs were removed after the destruction of the palace to be used as building-stones. The position of these removed slabs, and the extent of the stylobate are, however, demonstrated by



Fig. 88. Vouni. The palace. The column base in the E. corner of the central court with a small piece of the column shaft placed in position.



Fig. 89. Vouni. The palace. The column base in the E. corner of the central court. Remains of melted lead for fixing the column to the base.

the fact that the floor of lime-cement is preserved all around the stylobate, so that the parts where the slabs are missing now appear as straight-sided grooves in the floor. The stylobate extended along three sides of the central court: to the N. W., N. E., and S. E. The columns were raised on a low plinth, consisting of a rectangular slab of stone which rises 12.0 cm. above the top surface of the stylobate.

The columns are of two types. Type 1 has a cylindrical shaft, tapering upwards and with plain surface. The diameter of the base is 0.47 m. In section, the shaft of Type 2 has the shape of an ellipse with the short ends cut off. Two dimensions are represented: the one is 0.63 m. long and 0.43 m. wide at the base, and the other is 0.46 m. long and 0.40 m. wide. The length of the shaft is unknown. The lower part of a cylindrical column and fragments of the base of the columns of Type 2 are preserved, but as the relation between the base diameter and the length of the shaft is unknown the length cannot be exactly calculated.

The capital of one of the columns is preserved. It has the shape of a Cypriote variety of the Egyptian Hathor capital with a female head sculptured in relief on the two wide sides, and above the heads a niche with an *uraeus*. The capital is described in the Object Register, No. 290.

The shafts of the columns were fixed to the plinth by means of melted lead, of which pieces are preserved.

The position of three columns is given by the preserved plinths; the columns in the W., E., and S. corners of the stylobate. The position of the others is given by the preserved

substructures of cut stones below the plinth. It can thus be stated that there were four columns on the long sides and three columns on the short side of the peristyle, the columns in the corners between each long side and the short side included in the number of columns on each side. The columns in the corners were of Type 2 and the others of Type 1. The columns in the corners between the long sides and the short side were of the smaller size of Type 2.

At the level of the uppermost step of the staircase leading from the central court to Rooms 48, 51, 54, and in the longitudinal axis of Room 51, there is a distinctly marked, trapezoidal excision in the floor. This seems to mark the place of a plinth for a column supporting the wooden beam in the open front of Room 51.

In the open front walls of Rooms 125—127 there are rectangular stone slabs which seem to have been substructures for pillars, or columns supporting the roofs. In the front side of Room 125, there are three such slabs at a distance of c. 0.80 m. from each other, and in Rooms 126 and 127, there is a continuous stylobate of such slabs.

Staircases.

Stairs were used not only to lead to the upper story of the palace, but also on the ground-floor, to facilitate communication between rooms on different levels; these varied very much owing to the floors, following the natural rise and fall of the rock. Usually the stairs were staight, but there is one example of a three-flight staircase (Room 60), leading to the upper story. The short, straight staircases, communicating between rooms on different levels on the ground-floor, were, as a rule, built of stone blocks, but outside the palace some of the short stairs were rock-cut; the longer ones leading to the upper story were of wood resting on a stone substructure, or were entirely made of wood. The three-flight staircase was made of wood, and rested on a stone substructure.

The stairs are described below.

Short, straight stairs.

From the central court (Room 47), a magnificent staircase of seven steps leads up to Rooms 48—51—54. The staircase, which is 16.75 m. wide, extends across the whole width of the court. The steps are built of well dressed, rectangular blocks of *agriopetra*, and a special kind of *pouropetra*, called *kampanopetra*, because it rings when struck. Blocks of these kinds of limestone are used arbitrarily. The blocks rest on a stepped substructure of rubble. The blocks in the N. W. part of the staircase had been removed some time before our excavation by the owner of the field to be used as building-stones. The width of the steps is about 0.40 m. and their height about 0.13 m.

In Room 46 a stair of two steps leads up to the doorway between Room 46 and the S. E. courtyard. Each step is built of three blocks of hard Vouni limestone, with lime-mortar in the joints. The stair is founded on the rock and the floor of Room 46 abuts against it. The width of the steps is 0.30 m. and their height c. 0.20 m.



Fig. 90. Vouni. The palace. Staircase leading from the road along the N. E. front of the main temenos to Room 122 and the cemented water-conduit along the S. E. side of the staircase. In the background: staircase between Rooms 121 and 122.



Fig. 91. Vouni. The palace. Threshold slabs of gate of Room 100.

In the same room another stair of five steps leads up to the doorway between Rooms 46 and 60. The steps are built of single, large blocks of soft Vouni limestone on a substructure of small rubble, a single, horizontal block placed lengthways, and lime-mortar, which also is used in the joints. The stair is founded on the floor of Room 46, which indicates that it is a later addition, and an examination of Wall 56 shows, too, that the ashlar blocks have been removed and cut off in line with the sides of the stair, down to the lowermost course. The first and second steps are laid outside the wall on the floor of Room 46, the third and fourth steps are placed in the doorway and the fifth step reaches the floor-level of Room 60. The steps are c. 0.45 m. wide and c. 0.25 m. high.

In Room 55 there are traces of an earlier staircase which led up to Room 64 and a later, preserved staircase leading up to the same room. The earlier staircase was placed S. W. of the later one. It is entirely demolished, but has left traces in the floor of Room 55 where the steps, which rested on the rock, were removed without covering the part of the rock thus laid bare with floor cement. The width and extension of the stair, 1.40 m., are thus given. This stair led up to the lowermost floor of Room 64 which is evident from the fact that the later staircase, too, originally led up to the same floor (cf. below). It can be calculated that the stair reached the floor of Room 64 by four steps.

When Wall 129 (cf. p. 140) was demolished and substituted by the present, preserved wall 130, the later staircase was built N. E. of the earlier one. It is wider than that, being 1.85 m. wide. The steps are built of two or three blocks of soft Vouni rock and are wedged with chipped stones in the joints, except the third step, which is cut in the rock and at the

same time formed a substructure for the threshold of the doorway. The lowermost step is founded on the floor of Room 55 and the second step rests on a substructure of rubble founded on the same floor. The rock-cut third step reaches the ledge of blue-grey cement on the lowermost floor of Room 64 (cf. p. 149). The fourth step reaches the level of the middle floor and the fifth step the level of the upper floor of Room 64. It is thus evident that the stair originally had only three steps and that the fourth and fifth steps were added later, when the middle and upper floors in Room 64 were laid. The middle step, being substructure for the threshold, is widest, filling the whole width of the wall; the others are 0.35—0.50 m. wide and 0.20—0.25 m. high.

In the E. corner of Room 57 a stair leads up to Room 65. The steps are built of single blocks of soft Vouni rock. They rest on a substructure of rubble, a pair of ashlar blocks, and lime-mortar. Only three steps and part of the fourth step are preserved. The stair is founded on the upper floor of Room 57. As the stair is built along the doorway between Rooms 56 and 57 this was partly blocked up and Room 56 was entered from the steps of the stair. The steps are 0.25—0.35 m. wide and 0.20—0.23 m. high.

The stair between Rooms 57 and 27 is built of two blocks of hard Vouni rock in each step. It is founded on the rock which is cut in steps. Only the two lowermost steps and the uppermost are paved with blocks; the two middle steps are only rock-cut. The steps are 0.30—0.50 m. wide and c. 0.25 m. high; the third step is widest: it fills up the whole width of the wall and served also as a substructure for the threshold of the door between the rooms.

From Room 25 a stair leads up to Room 28 in the angle between Walls 12 and 159. The three steps are built of two blocks, one small and one large, and are founded on a substructure of rubble and lime-mortar. The stair rests on the floor of Room 25 and leads to the upper floor of lime-cement in Room 28. The steps are 0.40 m. wide and 0.22—0.24 m. high.

In the angle between Walls 136 and 159 a stair leads from Room 29 up to Room 50. Of the originally six steps only four are preserved. Each step consists of two or three blocks of hard Vouni rock wedged with chipped stones in the joints but with no binding material preserved. The stair is built on a substructure of rubble founded on the rock, and the floor of Room 29 abuts against the lowermost step. The N. E. flank of the staircase is revetted with orthostates and horizontal blocks placed lengthways. The steps are 0.40—0.45 m. wide and 0.15—0.17 m. high.

A staircase, which is 3.40 m. wide, and, consequently, much wider than the usual type, is built in the angle between Walls 18 and 161. It leads up from Room 20 to the upper story of Rooms 10—14. Each step consists of three to four blocks of hard Vouni rock without any preserved binding material in the joints. The steps are founded on a substructure of rubble which rests on the rock. The floor of Room 20 abuts against the stair. Only three steps are preserved. They are 0.40 m. wide and 0.15—0.18 m. high. The N. E. flank of the stair has been revetted with ashlar blocks of which a few are preserved.

Another, somewhat wider stair, measuring 3.75 m. in width, leads from Room 19 to Room 29. It is built of ashlar blocks of hard and soft Vouni rock in three steps, of which the uppermost is covered with the same kind of lime-cement as the floor in Room 29. The blocks rest



Fig. 92. Vouni. The palace. Staircase between Rooms 27 and 57.

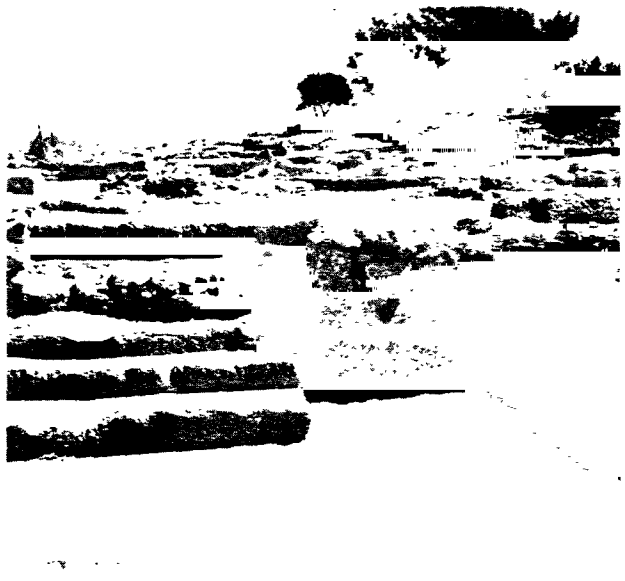

Fig. 93. Vouni. The palace. Staircase between Rooms 55 and 64; Walls 128 and 130 to the right.

on a substructure of rubble, founded on the rock, and the floor of Room 19 abuts against the stair. No binding material is used in the joints. Two blocks, one in each of the first and second steps are missing. The steps are 0.40 m. wide and 0.20 m. high.

The stairs between Rooms 31—32 and Rooms 32—33 have been rebuilt and united to one staircase, but originally they were separate. They are therefore conveniently described in one context. The original staircase between Room 31 and 32 began c. 0.55 m. further to the N. W. in Room 31 than the later staircase. Traces of the removed, lowermost step are there visible in the floor which has been repaired with lime-cement covering the part of the rock laid bare by the removal of this step. In the S. W. face of Wall 137, to which the blocks of the stair were bonded, the steps of the stair can be traced, too. The original staircase led up to the floor of Room 32 by three steps, 0.45—0.50 m. wide, i. e. wider than the normal width of the staircase steps, and 0.20 m. high. The original staircase between Rooms 32 and 33 is very narrow and measures only 0.65 m. in width. It is built of single blocks of hard Vouni limestone along the S. W. face of Wall 137 and led by four steps, c. 0.35 m. wide and 0.18 m. high, to a large landing block in front of the doorway to Room 33. This landing block rests on a substructure of orthostates and horizontal blocks placed lengthways. The stair thus ended on a line with the N. W. flank of the doorway to Room 33 and, consequently, the two stairs were originally separated by a narrow passage between Wall 77 and the stair to Room 33. This arrangement was found to be inconvenient and the two stairs were therefore joined together. For this purpose the earlier stair between Rooms 31 and 32 was demolished and replaced by the later stair, built of single blocks of hard Vouni limestone, and leading up to the landing block by four steps, 0.40—0.45 m. wide and 0.18—0.25 m. high, and a platform of lime-marl between the second and third steps. This platform served also as a threshold of the door between Rooms 31 and 32. The blocks rest on

a substructure of rubble. At the same time the stair in Room 32 was widened by three orthostatic blocks with lime-mortar in the joints, revetting a filling of rubble between these and the original flank of the stair. This added part is founded on the floor while the original stair is founded on the rock.

A wide staircase, measuring 7.70 m. in width and extending across the whole width of Room 7 A leads from that room to Room 37. It is the widest but one of the palace stairs: only the staircase between the central court and Rooms 48—54 is wider. It is built of well dressed and carefully joined blocks of *pouropetra*. Of the originally nine steps only the two lowermost are preserved. The other seven are reconstructed. The blocks rested on a stepped substructure of rubble and lime-mortar which is not founded on the rock but on the cement pavement of an earlier road running here (cf. p. 153). The steps are 0.30—0.35 m. wide and 0.14—0.18 m. high.

The staircase between Room 37 and the central court (Room 47) was found almost entirely destroyed and is reconstructed. Its width, 3.00 m., is given by the preserved edges of the cement floor which once abutted against the stair. It was built in three steps.

To the doorway in the S. E. wall of Room 103 a small stair leads in three steps, the two lowermost formed by single blocks of hard Vouni rock and the top step by the levelled rock. The blocks are founded on the rock-cut floor of the room. A similar, small stair consisting of only two steps is found between Rooms 116 and 110.

Between Room 125 and 126 a stair of five steps leads up from the road along the N. E. front of the main temenos to Room 122. The stair reaches the room in its E. corner. The steps are built of three to four blocks of rather soft Vouni limestone. The N. W. side of the stair abuts against Wall 46; along the S. E. side is a cemented water-conduit. The steps are 0.40 m. wide and 0.16—0.20 m. high.

Another, similar stair leads from Room 127 to the N. corner of Room 122. It has three steps, built of the same kind of limestone as the previous stairs. The steps are 0.40—0.45 m. wide and 0.15—0.20 m. high.

In the S. corner of Room 122 there is a narrow stair of four steps leading up to the doorway of Room 121. The steps are built of blocks of soft Vouni rock and rest on a substructure of small rubble and lime-mortar. In front of the doorway of Room 121 is a large landing block. The steps measure 0.30 m. in width and 0.17—0.22 m. in height.

Room 123, the altar court of the main temenos, was entered from Room 122 by a wide staircase across the whole width of the front side of the court. The stair reached the level of the court by four steps; of these, however, only the rock-cut substructure is preserved with exception of a single block of the lowermost rock step. All the other blocks have been removed. The blocks of the first step rested on the floor of Room 122, which in front of the stair consists of the cut rock (cf. p. 148). It was flanked on both sides by votive sculptures, of which the bases were found *in situ* while the sculptures themselves were found tumbled down in a more or less fragmentary state of preservation (cf. p. 277).

A narrow, rock-cut stair of five steps leads from Room 129 to the E. corner of Room

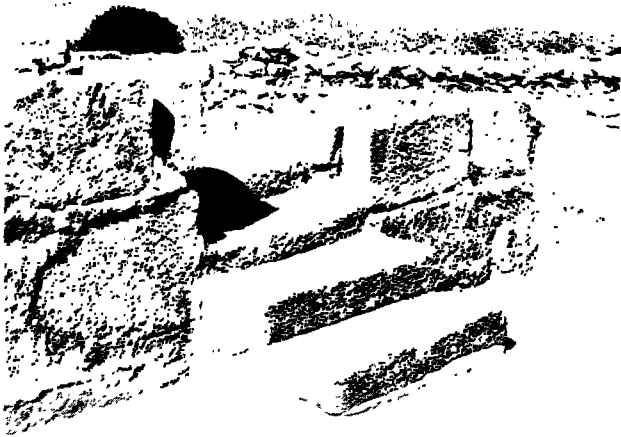

Fig. 94. Vouni. The palace. Staircase between Rooms 46 and 60 through Wall 56.

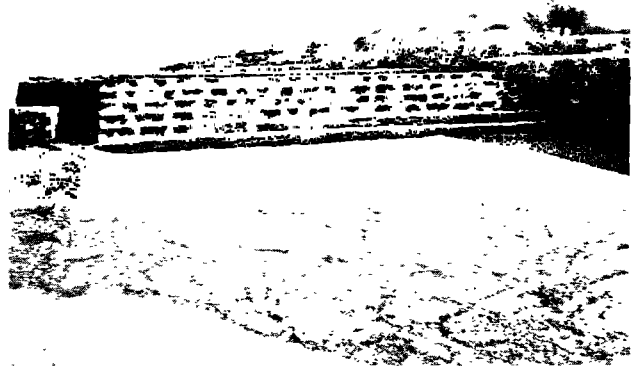

Fig. 95. Vouni. The palace. Staircase between Rooms 7 A and 37.

124. The steps are 0.35—0.40 m. wide and 0.19—0.25 m. high. As the steps are worn, it seems unlikely that they were covered by stone blocks.

Other rock-cut stairs, partly with preserved stone blocks are found, which facilitate communication between the different levels of the roads outside the palace. Remains of such stairs are found N. W. of Room 117, W. of the main temenos, and S. of the chapel of Rooms 132—135.

Long, straight stairs.

In Room 17 a staircase of this type was built along Wall 18. It has been 4.35 m. long and 1.00 m. wide and led to the upper story, to the room above Room 16. The stair is founded on the floor of the room and consists of a substructure of rubble on which the steps rested. Of these only the three lowermost steps built of single blocks of soft Vouni rock are preserved. The height of these steps varies between 0.18 and 0.20 m. The steps of the upper part of the stair were probably of wood, as there is no indication that the stone substructure ever was higher and it does not continue to Wall 17, but there is a passage between the substructure and the wall, which in consideration of the fact that the upper wall was of mud-brick, could only have been bridged over by a wooden structure. The number of steps can be calculated to thirteen. With an average height of 0.19 m. the uppermost step would be about 2.50 m. above the lowermost, but the floor-level of Room 16 is on an average 0.75 m. below the floor-level of Room 18 at the base of the staircase. The height of Room 16 can thus be calculated to about 3.25 m.

Along Wall 148, in Room 64, there is a similar substructure for a stair, which, however, is only 1.50 m. long and 0.95 m. wide. Only the lowermost of the steps, consisting of a worn block of rather soft Vouni rock is preserved. As the stone substructure is much shorter than that of the previous stair and there is a passage of 1.65 m. between it and Wall 99 to be brid-

ged over, it is evident that the upper part of the stair must have been of wooden structure. Remains of the wood were found in the E. corner of Room 64, where a distinctly limited accumulation of carbonized matter and ash was found, exactly in position below the upper, wooden part of the stair, which consequently was burnt. The stair has led up to the roof of Room 77: on account of the narrow walls of this and the adjoining rooms it seems unlikely that this part of the palace ever had an upper story. On the other hand it is possible that Rooms 69, 71—73, the walls of which are of normal width, had an upper story which then would have been reached by means of this staircase across the roof of Rooms 75—77, forming a balcony in front of the rooms of the upper story.

In the description of the walls it has already been mentioned (cf. pp. 133 f.), that there was originally a staircase running along Wall 8 and leading to the upper story, to the room above Room 13. This staircase was later rebuilt to Wall 76 when Wall 8 was demolished (cf. p. 134). The existence of the staircase is proved by the fact that the rock-cut elevation on which Wall 76 is founded is cut in steps forming the substructure for the staircase. Moreover, some of the blocks used in the wall, are not usual ashlar blocks but rectangular blocks of the kind used for the steps in the staircases. The stair has been c. 7.00 m. long and 1.20 m. wide. If we suppose a width of c. 1.20 m. for the door leading from the landing place of the staircase to the room above Room 13 the stair has consisted of about fifteen steps and with an average height of about 0.20 m. for each step the upper story would be about 3.00 m. above the average floor-level of Rooms 10—14. We obtain the same result if we calculate the height of the rooms on the evidence of the top level of the stair which from Room 20 has led to the same room above Room 13 (cf. p. 158). The top level of that stair has been about 112.5, as the fourth step which is the uppermost preserved of the original six steps is at level 109.5—109.6 and the height of each step is about 0.15 m. This level of 112.5 is about 3.00 m. above the average level of 82.5 of the floors of Rooms 10—14.

Apart from these long, straight stairs of which the stone substructures are preserved there are traces of other similar staircases entirely built of wood. The existence of such a staircase leading to the upper story along Wall 183 can be proved on stratigraphic evidence (cf. p. 182). Close by Wall 183 there was a thin layer of red sand on the floor. This sand had evidently drifted there through an oblong hole in the roof before this collapsed because pieces of ceiling lime-earth of the roof were found on top of the sand layer. These stratigraphic conditions seem to be best explained by assuming a wooden staircase leading down to Room 43 from the upper story: the only possibility of entering Room 43 after the erection of Wall 183. It is to be supposed that there was a similar staircase in Room 44, though the stratigraphic conditions did not give information about that.

T h r e e - f l i g h t s t a i r c a s e .

There is only a single staircase of this type: that one which led from Room 60 to the upper story, to the room above Room 46. Of the stair only the stone foundations serving as substructure for the wooden stair are preserved. A thick layer of carbonized matter and ash



Fig. 96. Vouni. The palace. Staircase between Rooms 31 and 32; Walls 107 (right) and 137 (left).



Fig. 97. Vouni. The palace. Staircase between Rooms 26 and 28.

found in Room 59 shows that the stair was burnt by fire at the destruction of the palace. The stair started in Room 60 which forms the base platform with a slightly rising cement floor. From this platform the stair led by a flight of steps to the first landing-place in the S. corner of Room 59; then by another flight of steps to another landing-place in the W. corner; and, finally, by a third flight of steps up to the doorway of the upper room 46.

Cisterns, water-conduits, and drainage.

The cisterns are of four main types: tank-shaped, well-shaped, bottle-shaped, and bell-shaped. The water was carried to the cisterns in conduits of three different types: terracotta pipes; open, cemented drains, V-shaped in section; and cemented drains covered by stone slabs. The terracotta pipes were used to carry the water from the roof along the walls in roofed-in rooms; the open, cemented drains were used for the same purpose in open places within the palace; the covered drains were used for the conduits below the floors. On the floors the open drains end in round, cemented basins from whence the water ran in covered drains below the floors to the cisterns. The terracotta pipes do not open into such basins but into the covered drains below the floors.

The original cistern in the central court is tank-shaped, an oblong shaft c. 6.80 m. long and c. 3.00 m. wide, cut in the rock to a depth of c. 7.90 m. below the floor-level. The inside of the cistern is coated with a very hard, blue-grey lime-cement. In places where this was necessary on account of irregularities in the rock its edges are heightened to the floor-level by superimposed ashlar to serve as substructure for the floor and the cover of the cistern. It cannot be ascertained how the covering was arranged but probably the cistern was covered by a wooden floor resting on beams across the opening of the shaft.



Fig. 98. Vouni. The palace. Cemented basin of water-conduit in Room 28.



Fig. 99. Vouni. The palace. Cemented basin of water-conduit in Room 26.

This cistern was filled with water running in two water-conduits opening into the cistern below the floor, one on the S. E. long side and the other on the N. W. long side of the cistern. The S. E. water-conduit comes down from the roof in terracotta pipes along the W. corner of Room 44. The pipes are fixed to the wall with lime-mortar. Below the floor a covered, cemented conduit carried the water to the cistern, opening on to it near its N. E. end. The N. W. water-conduit has come down in terracotta pipes from the roof of Room 34+35, but of these nothing is preserved. Only a part of the cemented, covered conduit below the floor of the central court was found intact. It opens on to the cistern at the middle of its N. W. long side. This conduit went out of use when the original cistern was rebuilt (cf. below) and the water pipes were therefore removed. It seems most likely that they were placed in the S. corner of Room 34+35 as Walls 74 and 75 were built contemporarily with the rearrangement of the cistern and no earlier wall existed there (cf. p. 190). The water collected on the roofs of the rooms N. W. of the central court was thus carried to the cistern by the N. E. conduit and the water from the roofs of the rooms on the N. W. and S. W. sides of the court by the S. W. conduit.

In Room 35 a cylindrical, well-shaped cistern is cut in the rock to a level of 8.50 m. below the floor-level which is c. 0.10 m. below that of the central court; consequently the cistern in Room 35 is 0.50 m. deeper than the cistern in the central court. The inside of this well-cistern is coated with lime-cement of the same kind as the cistern in the central court and the opening of the floor of Room 35 is surrounded by a circular, raised edge of lime-cement. A subterranean passage is cut in the rock, 0.50 m. above the bottom of the well-cistern. It is coated with lime-cement of the same kind as the cisterns; it is 0.50—0.70 m. wide and 1.50—1.60 m. high; its roof is cut in shape of a pointed arch. This passage leads to the cistern in the central court but its opening there has been filled up with lime-cement in connexion



Fig. 100. Vouni. The palace. Mouth of the cistern in the S. E. court (Room 83).



Fig. 101. Vouni. The palace. Room 91.

with the rebuilding of the cistern (cf. below). The tank-cistern in the central court and the well-cistern in Room 35 thus communicated with each other: the water collected in the tank-cistern was drawn up from the well-cistern. The latter was cut 0.50 m. below the bottom of the tank-cistern and the rock-cut passage in order to collect the dirty particles of the water on the bottom of the well-cistern so that they did not accumulate in the passage and obstruct the communication between the cisterns. As a matter of fact this deepened part of the well-cistern was found full of earth, pieces of broken pottery, and a bronze jug dropped in the cistern.

Such were the original arrangements. Later, these were considered inconvenient and the cisterns were rebuilt. From the bottom of the N. E. part of the tank-cistern, a new, deep cistern was cut out of the rock to a depth of 14.85 m. below the bottom of the earlier cistern and 22.75 m. below the floor of the central court. The new cistern has the shape of a beer-bottle with the neck tapering upwards, and its inside coated with lime-cement of the usual kind. On top of this bottle-shaped cistern another one of similar shape was built within the N. E. part of the earlier tank-cistern by building a circular wall of horizontal blocks placed lengthways across the middle of this cistern and along the sides of its N. E. part. The lower part of the wall was cemented on the outside across the middle with an unusually hard, dark-grey cement, so hard that it cannot be chipped with an iron pick-axe. The circular wall tapered upwards by means of a corbel-vault forming the neck of the "bottle" and its inside was coated with lime-cement of usual kind. The rebuilt cistern thus consists of two bottle-shaped cisterns, the one on top of the other. The floor around the cistern had been purposely removed and the mouth lacked its superstructure. Only the substructure of cut limestone blocks was preserved (cf. below). The top blocks of this substructure on which the raised superstructure of the mouth would have rested were placed in rows radiating from



Fig. 102. Vouni. The palace. Cemented water-conduit below the floor of Room 28.



Fig. 103. Vouni. The palace. Room 76. Sink (left) and waste-conduit (right).

the opening of the cistern. By this arrangement, the S. W. part of the earlier tank-cistern was put out of use and was filled in with chips of Vouni rock and covered with a floor of white lime-marl. The well-shaped cistern, in Room 35, became superfluous, too; it was filled in with sandy earth, greenish in colour, and its mouth was covered with the second floor in Room 35 and partly cut off by the erection of Wall 74 (cf. p. 133).

A special construction for hoisting water from this deep cistern was found necessary. Originally a hoisting structure of wood seems to have been used with a rolling cross-beam resting on two wooden stands. This is indicated by the discovery of a rectangular hole in the lime-marl floor S. W. of the cistern. The hole was filled with dark, organic earth which seems to be remains of mouldered wood. On the opposite side of the mouth of the cistern the floor was destroyed as mentioned above, and a corresponding hole there could not therefore be observed. This wooden structure was replaced by a similar one of stone when the palace was destroyed. This is indicated by the discovery of a stele of limestone found on the floor of the central court, close by the cistern. This stele (see Obj. Register, No. 289) is similar in shape to the specimen of the Cypriote variety of the Hathor capital found in the central court and used as capital of one of the columns of the peristyle (cf. p. 155 and Obj. Register, No. 290). The stele has a rectangular groove on the top for receiving the cross-beam of the hoisting structure and on each of the wide sides an unfinished, female relief head. It is thus evident that the plan of replacing the wooden stands of the hoisting structure by sculptured stelae of stone was not carried out when the palace was destroyed, and this is consistent with the fact, mentioned above, that the floor around the cistern had purposely been removed and its mouth lacked the finishing superstructure. Both these facts indicate that the arrangements around the cistern were being repaired at the time of the destruction of the palace.

The cistern was filled with water through the S. E. conduit coming from Room 44, which was one of the conduits used to fill the earlier, tank-shaped cistern. The N. W. conduit

on the other hand could no longer be used as it opened outside the later, rebuilt cistern. As there is no evidence that this conduit was replaced by another one, the water collected on the roofs of the rooms N. W. of the central court must therefore have been carried to another cistern, probably to that in Room 19 (cf. below).

In the N. E. part of the S. W. court (Room 83) there is a well preserved cistern cut in the rock. In shape it resembles the lower "bottle" cistern in the central court and is 15.30 m. deep. The hard crust of the limestone rock is very thick on this place and that explains why the neck of the bottle is rather long: the cistern does not widen before 5.00—7.00 m. below the surface. The inside is coated with a lime-cement of the usual kind. Around the mouth of the cistern there is a superstructure of cut limestone blocks, placed in two concentric, stepped courses and covered by the same cement as in the cistern itself. To the N. there is an U-shaped basin added to the superstructure. The walls of the basin are coated with lime-cement and its bottom consists of the rough rock. In the N. part of the basin there is a rectangular groove for the affluent water and there is a corresponding groove in the superstructure of the mouth of the cistern for its outlet. This arrangement served to clear the water: the dirty particles in the water filling the basin, sank to the bottom before the water reached the upper edge of the basin and poured into the cistern. The conduit by which water was carried to the cistern is not preserved, but the northern direction of the grooves in the edges of the basin and the superstructure indicates that the water-conduit has run to the N. corner of the court, at the entrance of Room 84, and from there along the wall up to the roof of Room 86. The water filling the cistern was thus collected on the roofs of the rooms on the N. E. and S. E. sides of the court.

In Room 61 there is a cistern of the bell-shaped type. Its filling of earth was not cleared out on account of the dangerous condition of the rock so that its depth is unknown. It was filled with water running in a channel in the lowermost floor of the room and ending with an outlet, rectangular in section, cut in a stone slab. The inside of the cistern is covered with cement as usual, but no raised rim around the mouth was preserved. The cistern was covered by the upper floor of Room 61: it was thus in use only during the time represented by the lowermost floor of the room (cf. p. 195) and served as a receptacle for the water collected on the roofs of the adjoining rooms 62, 63, 74, 75, 77—80, and possibly those of Rooms 54—56, too. When the cistern fell out of use the water collected on the roofs of these and the other, newly built rooms 71—73, 76 (cf. p. 197) must have been carried in gutters to the bottle-shaped cistern in the central court.

In Rooms 19 and 26 there are two cisterns of the same bell-shaped type with cemented insides. They were filled with earth to 2.00—5.00 m. from the top and were never excavated, so that their depth is unknown.

The mouth of the cistern in Room 19 was surrounded by a substructure of thick, short blocks founded on the rock, but the superstructure was missing. The cistern received water in four conduits: one coming down along Wall 158 to a collecting, cemented basin on the floor of Room 28, and continuing to the cistern below the cement-floor of this room, and in Rooms 29 and 19; another, covered channel is found below the floor of Room 30, but could



Fig. 104. Vouni. The palace. Room 61. The cistern in the foreground and Wall 147 with a rectangular hole for a drainage channel.



Fig. 105. Vouni. The palace. The circular wall of the bottle-shaped cistern built into the tank-cistern in the central court.

not be traced further; a third channel comes down Wall 107 to a cemented, collecting basin in the corner between Walls 105 and 107 and from there it continues below the floor where it unites with the covered channel from Room 30 by means of a lead pipe; the fourth channel comes down Wall 18 to a cemented basin on the floor of Room 18 approximately opposite Wall 10 whence the channel continues below the floor to the basin in the S. corner of Room 18, where it unites with the third channel. The water on the roofs of the rooms adjoining to the S. W. was collected by the first conduit, and the second conduit probably collected the water from the roofs of the rooms N. W. of the central court. It was shown above, p. 167, that the water from the roofs of these rooms which had originally been carried to the tank-cistern in the central court, was not collected in the rebuilt, bottle-shaped cistern in the same court. It had then to be collected in another cistern, and for that purpose, the cistern in Room 19 was nearest at hand. This supposition agrees with the fact, that the water-conduit was evidently placed below the floor of Room 30 after this was laid, as the floor was damaged and repaired exactly above the conduit (cf. p. 151). The third conduit collected the water on the roofs of the rooms to the S. W. and W. of the central court and the water on the roofs of Rooms 10--12 was collected by the fourth conduit.

The mouth of the cistern in Room 26 is bordered by four orthostatic blocks of which two have fallen into the cistern. The top of the blocks is on a level with the rock surface. On top of two of these blocks two other orthostatic blocks are placed on opposite sides of the mouth of the cistern. The cistern was fed with water by a single conduit leading down along Wall 160 to a cemented basin and from there by a covered conduit below the floor to the



Fig. 106. Vouni. The palace. Drainage channel in Room 124 with Wall 184 in the background and Wall 185 to the right.



Fig. 107. Vouni. The palace. Drainage channel along the S. W. exterior wall of the main temenos; Room 122 to the left in the background.

cistern. The conduit collected the water from the roofs of Rooms 21—23 and, probably, Rooms 13 and 14, too, as the water collected on the floors of the small rooms 21—23 does not seem to have been of such a quantity that a cistern of this size was necessary for the purpose.

Outside the palace there are two cisterns, one S. W. of the palace and the other N. E. of the main temenos. The cistern S. W. of the palace is situated c. 7.00 m. S. W. of Wall 34. It is of the bell-shaped type and the inside is cemented. Its depth is unknown as it was never excavated. The cemented mouth of the cistern has been mended with flat stones in ancient times. The cistern received water by a rock-cut channel coming from Room 67, and passing through Walls 83 and 13, carrying off the water slopped on the floor of this room which seems to have been used for washing. The water collected in the cistern was not therefore clear rain-water as that filling the other cisterns described above, and cannot have been used for drinking.

The cistern N. E. of the main temenos is situated near the wall supporting the terrace of the road there, at the point where this wall makes a sharp turn opposite Rooms 128 and 129. The cistern is of the "bottle" type, the lower part cut in rock and the upper part built of cut stones in the technique of a corbel-vault. The mouth is surrounded by a rim of small rubble, as a substructure for a cemented edge which is now missing. The grooved end block of a water-conduit is preserved at the mouth of the cistern. This conduit has been covered with stone slabs as can be seen from one preserved slab found *in situ*. This is an indication



Fig. 108. Vouni. The palace. The substructure for the mouth of the bottle-shaped cistern in the central court. Part of the tank-cistern behind. Staircase between the central court and Rooms 48—51—54 in the background.

that the conduit was laid below the pavement of the road. From the direction of the preserved part of the conduit it is evident that it ran in E. and S. E. direction along the terrace wall, but no remains of it were left. It seems however probable that it was connected with a cemented conduit which runs along the S. E. side of the staircase leading to the E. corner of Room 122 (cf. p. 160). This conduit has continued along Wall 169 up to the roof of Room 125, and has carried off the water collected on the roofed-in parts of the temenos.

Drainage channels served to carry off the rain-water falling on the floors of the open spaces within the palace, and on the roads outside it, and the water poured out on the floors of the wash-rooms, bath-rooms, and sculleries. The drainage channels, too, are of different types: outside the palace and on the open spaces within it, they are cut in the rock and sometimes cemented as the open water-conduits; when they are located below the floors, or pass along or through the walls, they are cut out of stone blocks and are rectangular in section.

The drainage channels carrying off the water slopped on the floor of Room 67 to the cistern S. W. of the palace has already been mentioned.



Fig. 109. Vouni. The palace. The substructure for the mouth of the bottle-shaped cistern in the central court with one stela of the hoisting structure placed in position. Behind the cistern, part of a cylindrical column erected on one of the peristyle bases. Walls of Rooms 42—44 in the background. The damaged floor around the cistern restored with straight edges.

Another drainage channel cut in a stone block inserted in Wall 30 carried off the water from Room 76 which was a scullery as shown by the sink built in a platform of rubble along Wall 142 (cf. p. 142). This sink is rectangular, 1.25 m. × 0.60 m., and built of orthostatic blocks. It was filled to its upper edge with pieces of smashed terracotta vases. In the S. E. short side of this sink, there is an outlet for the dirty water.

In Wall 147 there is a rectangular hole for a drainage channel carrying off the water from the second floor of the room to the S. E. court (cf. p. 142). The relation of this hole to the floor proves, that the hole was opened in the wall after its erection and after the floor was laid (cf. p. 196). The drainage channel can be traced by cuttings in the rock along the exterior of Wall 147; it seems to have continued in N. E. direction to a drainage hole in Wall 153, passed through Room 84 to another drainage hole cut in Wall 58 (cf. p. 129) and opened into the corridor 85 whence the water ran through the narrow doorway in Wall 62 to the road along the N. E. exterior wall of the palace.

In the E. corner of Room 42, there is a similar drainage hole (cf. p. 152) carrying off the



Fig. 110. Vouni. The palace. W. part of the central court before restoration. Mouth of the cistern to the right; Rooms 43—45 in the background.

water slopped on the floor of that room to the corridor 85. Another channel, cut from several stone blocks which are fixed to Wall 51 with lime-mortar, carried off the dirty water from Room 40 to the same corridor.

In Room 28 there is a channel cut in the rock-floor which opens into a drainage hole in Wall 12, which later was blocked up in connexion with the cement floor being laid in Room 28 (cf. p. 151). The water streamed through this hole down a cavity in the rock below the floor, outside Wall 12. This cavity was filled in when the hole was blocked up and the drainage fell out of use.

Cemented drainage channels carried off water poured on the floors of Rooms 22 and 23 through Wall 57. Outside this wall the channels were united.

At the exterior doorway leading to Room 57 there are other drainage channels cut in the rock to carry off the water from the door and prevent streaming into the room.

A similar channel cut in the rock passes Room 16 along Wall 17, through Wall 162 to the open space outside the palace in front of Rooms 10 and 16. From the doorway between Rooms 16 and 17, the drainage channel runs below the floor of Room 17 to a cemented water-basin located at the inner face of Wall 17 in the open space between that wall and the N. E. end of Wall 18. This water-basin has been almost demolished, but the preserved part shows that it has been of the same construction as all the other water-basins to which the water-conduits from the roofs descended, as described above. This

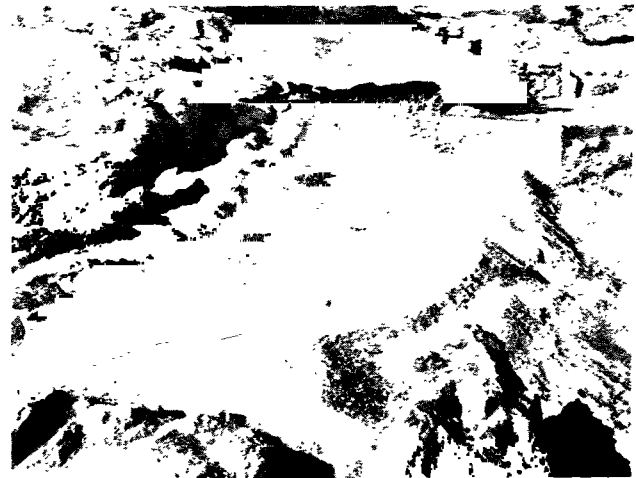

Fig. 111. Vouini. The palace. Room 22. Cemented outlet for the water.

Fig. 112. Vouini. The palace. Cemented water-basin in Room 106.

demolished water-basin has received water from a conduit from the roof of Room 16 and the water was carried off by the drainage channel from the basin to the sloping rock in the open space between Rooms 10 and 16. That the water collected on the roof was not conducted to a cistern, but was allowed to be wasted is a unique phenomenon which is explained by the fact that on account of the lower level of the roof of Room 16 than those of the adjoining rooms the water would have to be collected in a special cistern (cf. p. 210).

The rain-water falling on the floor of the central court was carried off by a cemented drain with a circular mouth opening in the cement floor approximately in the middle of the N. E. stylobate. The floor of the central court slopes slightly towards this mouth of the drain. The drain ran below the floors of the N. E. peristyle and Room 38, passed through Wall 119 A; it continued in the rock and can be traced down to a cemented channel which is cut along the S. W. wall of the main temenos. This drain prevented the water from pouring into the temenos. Opposite the place where Wall 170 makes an angular turn (cf. p. 144) is the highest point of the drain, forming a watershed from where it slopes to the N. W. passing through Wall 184 down the rock floor of Room 124 to Room 129 and to the S. E. to a point outside the S. corner of Room 121, where it unites with a drain that can be traced across the road running along Rooms 86—91 to the rocky slope outside the S. E. exterior wall of the palace. From the meeting place of these drains, they continue in a single drain along the S. E. walls of Rooms 121 and 125 down to the road along the front side of the main temenos.

In Room 106, finally, there is a large water-basin, 3.40 m. × 1.20 m., built of blue-grey cement and a substructure of white and red lime-marl on an elevation of the rock. This water-basin extends across the whole width of the room along Wall 113 and has an outlet through this wall. The edge of the basin rises 0.15—0.20 m. above the floor of the room; its N. corner is rounded off, and the bottom of the basin slopes towards the outlet.

Hearth.

A hearth was found on the lower earth-floor of Room 75. It consists only of an open cooking place on the floor surrounded by semicircular settings of stones along Wall 96. The stones are blackened by fire and the place within was covered by a layer of carbonized matter and ash. The cooking seems to have been done in pots placed on stands of stones, or tripods of other material, terracotta or metal. This primitive cooking place is astonishing, considering the magnificent architecture of the palace.

The upper floor of Room 75 was not much preserved (cf. p. 153); neither are there any traces of the hearth belonging to this floor.

Altars.

In Room 113 there is a rectangular altar, 2.70 m. \times 1.45 m., with its N. E. short side abutting against the middle of Wall 40. It is of small rubble which in the superimposed courses are placed obliquely to each other, forming a herring-bone pattern. The faces of the altar are not coated with any kind of lime-mortar contrary to those of the following altars.

Another, square altar is found in the middle of Room 117. It is built of rubble with ash-lars at the corners. The altar measures 1.95 m. \times 1.70 m. The lower part of the faces are surrounded with a layer of lime-mortar, but the stones are not coated with the mortar, there being an interstice of 5 cm. between these and the mortar. Probably the faces of the altar were revetted with wooden planks which were coated by the lime-mortar.

On the front side of the altar, close by its E. corner, there is a small, square structure added to it. It measures 0.55 m. \times 0.45 m. and is built of rubble with the faces coated by lime-mortar.

Four altars are erected in Room 123, the altar-court of the main temenos. Of these, two are circular and the other two are semicircular. The circular altars, measuring 0.90—0.95 m. in diameter, are built of lime-mortar to a height of 0.30 m. above the rock. Of the E. of the circular altars, only the half is preserved. Close to these altars, accumulations of carbonized matter and ash were found. The semicircular altars have a diameter of 1.80—1.85 m. and a height of 0.40—0.65 m. They are built of a core of rubble revetted along the semicircular circumference by a thick layer of lime-mortar of the same kind as that revetting the other altars. The core of rubble is not preserved in the E. of the two semicircular altars.

Varia.

In Room 110 there are two square structures, 1.05 m. \times 0.75—0.85 m., built of roughly cut stones. They are placed symmetrically opposite each other. Their purpose is uncertain.

Along Wall 189 there are two parallel rows of orthostatic blocks at a distance of 1.50 m. from each other and with a length of 2.15—2.25 m., and in Room 109 there is a single row of orthostatic blocks at a distance of 1.60 m. from the N. E. wall of the room (now destroyed) and parallel to that wall. Parallel with Wall 112 and at a distance of 0.45 m. from it



Fig. 113. Vouni. The palace. Semicircular altar in the main temenos (Room 123).



Fig. 114. Vouni. The palace. Altar in the cult-chapel, Room 117.

there is a short piece of a wall, at right angles to this row of orthostates. The purpose of these structures, too, is uncertain.

SECTIONS AND STRATIFICATION (FIGS. 115—118; PLANS X—XV)

Several sections through different parts of the palace show the interrelations of the levels of floors and walls and explain the stratigraphic conditions on and above the floors.

Sections I—VIII are purely architectural and Sections IX—XXX are stratigraphic.

Section I (Plan X, 1).

This section runs in S. W. direction from Room 88 through Rooms 92—97 to Room 98.

Section II (Plan X, 2).

This section runs parallel with Section I. It begins in Room 86, crosses Wall 58 and the S. E. court (Rooms 81—83) running somewhat to the N. W. of the longitudinal axis of the court, and through Rooms 80, 79, 76, 73, 72 to Room 71.

Section III (Plan X, 3).

The section begins in the open front side of Room 126 and crosses that room and Room 122 in S. S. W. direction; then it turns to the S. W. running parallel with Sections I—II, crossing the roads along the N. E. exterior wall of the palace and Rooms 40, 42, 44, 45, 46, 60, 59, 63, 64, 66—68.

Section IV (Plan X, 4).

This section runs parallel with Section III. It starts at the terrace wall, supporting the filling of the road running along the N. E. side of the main temenos, and crosses Rooms

128 and 123 in S. S. W. direction; then it turns to the S. W., crossing the roads along the N. E. exterior wall of the palace, and cuts through Room 38, the central court (Room 47) with the cisterns in the middle of the court and Rooms 51—53, 57, and 58.

Section V (Plan X, 5).

This section runs in S. W. direction, parallel with Sections I—II. It begins at the terrace wall supporting the filling of the road between the main temenos and the cult-chapel of Rooms 132—135, crosses this road and the road along the N. E. exterior wall of the palace; then it crosses Rooms 7 B, 8, 16—22.

Section VI (Plan X, 6).

This section runs in S. W. direction through the palace; beginning in Room 98, it crosses Rooms 100, 76, 75, 64, 56, 52, 50, 29, 25, 20 and ends in Room 13.

Section VII (Plan X, 7).

This section runs parallel with Section VI. It starts in Room 93, crosses the S. E. court and the cistern there, Rooms 43, 44, the central court (Room 47) and the bottle-shaped cistern, Room 35 and the well-shaped cistern, Rooms 34 and 16. In the central court the section makes two angular turns to the S. W. and in Room 34 a third, angular turn in the same direction.

Section VIII (Plan X, 8).

This section runs parallel with Sections VI—VII. Starting in Room 91, it crosses Rooms 88, 87, 86, 85, 42, 39, 38, 37, 7 A, and ends in Room 1.

Sections IX—XI (Plan XI, 1—3).

The stratification of Rooms 86—88 is given by these sections. They are cut at right angles through the earth of each room: Section IX from Wall 70 to Wall 60, Section X from Wall 60 to Wall 58, and Section XI from Wall 61 to Wall 58. The stratification is uniform in all the rooms, and consists of the following layers:

1. Surface layer.
2. Layer of grey and white mud-brick and decomposed mud-brick earth.
3. Bottom layer of red mud-brick earth.

The grey and white mud-bricks are best preserved in Room 88, where many specimens are entirely preserved and their size and shapes could be determined (cf. pp. 145 f.). The stratification shows that the red mud-bricks which form the bottom layer, have been used higher up in the wall than the grey and white mud-bricks. Probably the walls of the upper story were built of red mud-bricks and those of the ground-floor of the grey and white mud-bricks.

VOUNI

The palace

Section IX

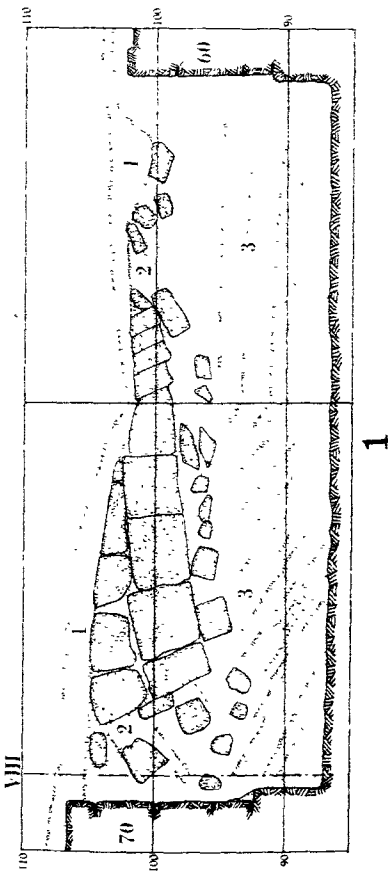

1

Section X

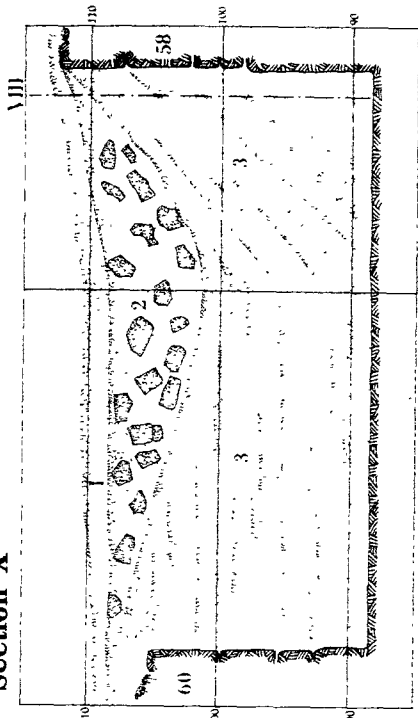

2

Section XI

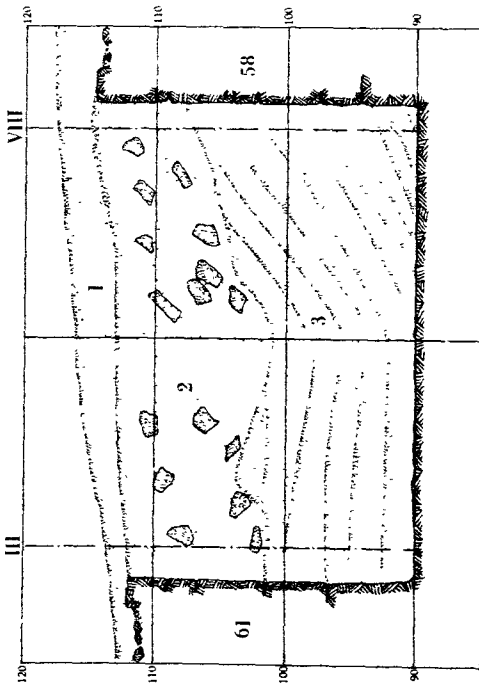

3

Section XII

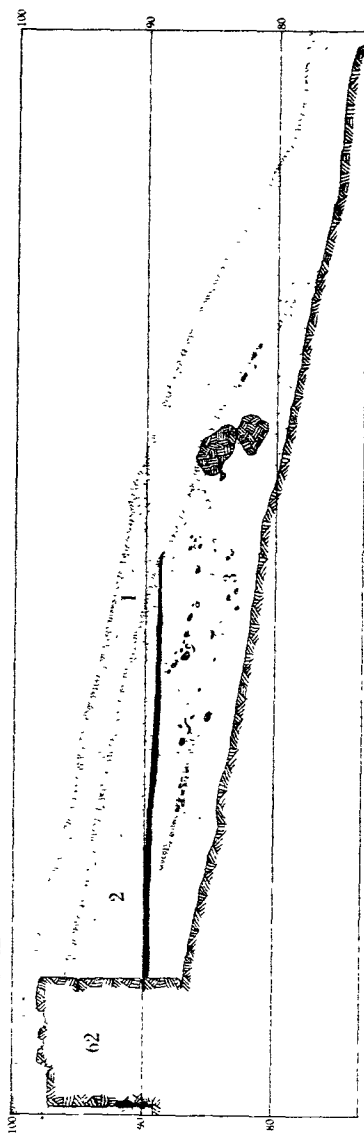

4

Section XIII

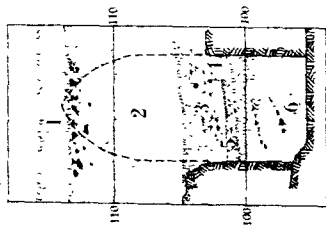

5

Section XIV a-b

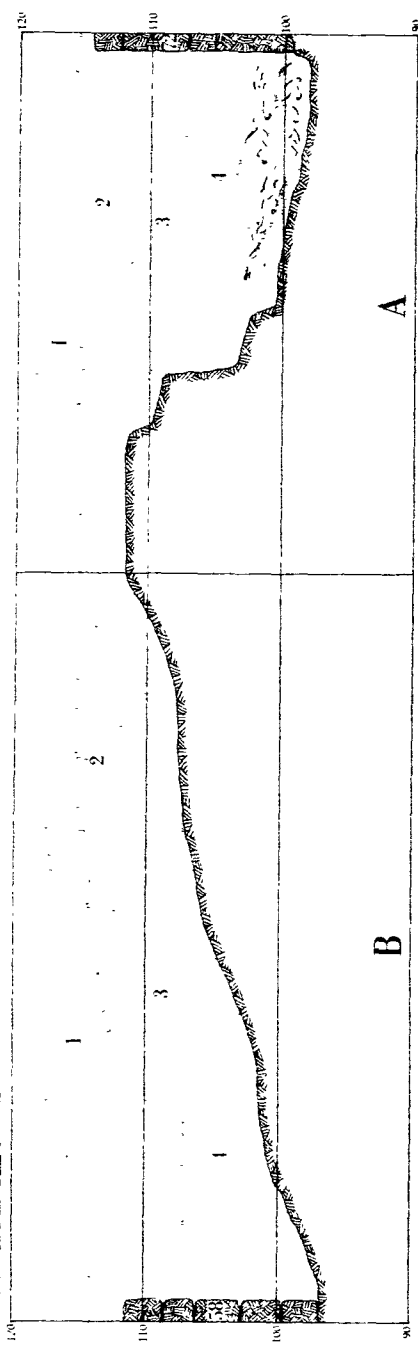

6

Section XIV c XVA

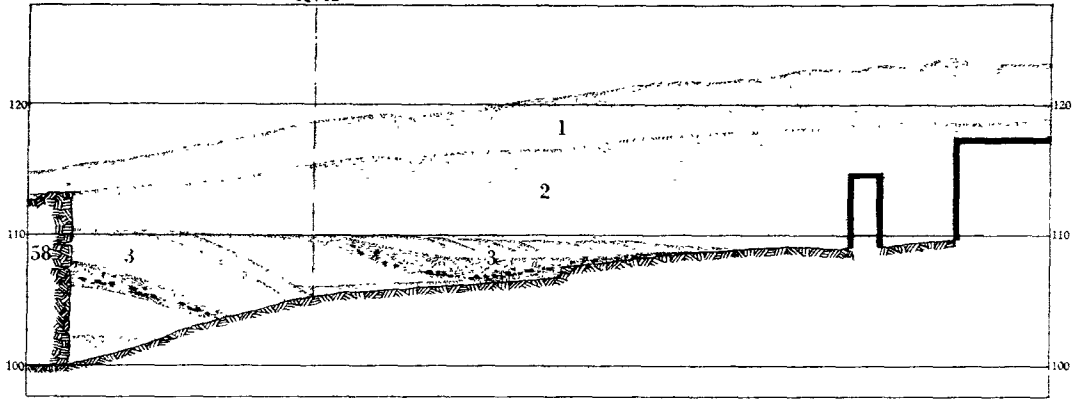

1

Section XV a

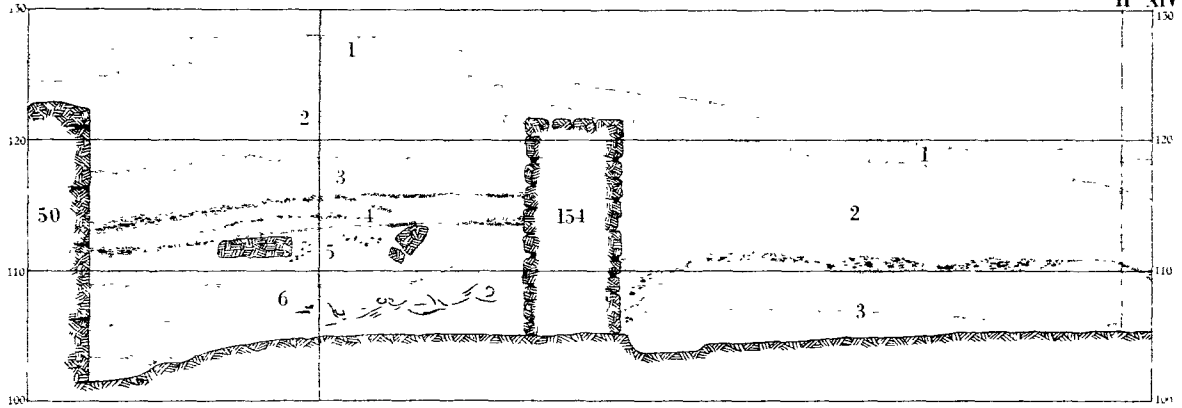

2

Section XV b

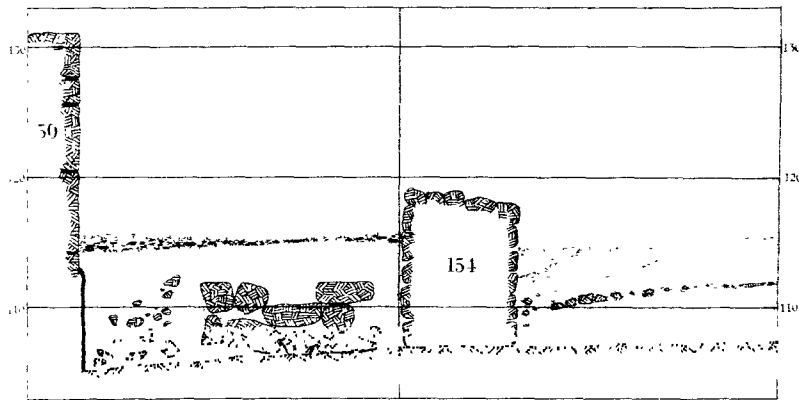

3

Section XVI

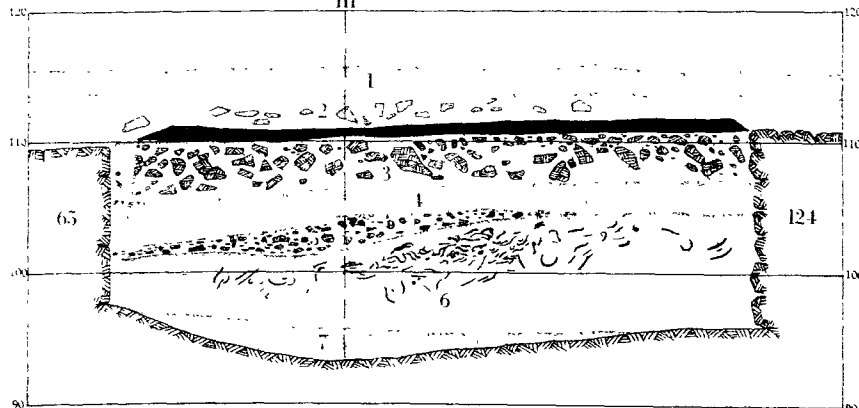

4

Section XII (Plan XI, 4).

This section shows the stratification of the S. E. part of the road running along the N. E. exterior wall of the palace. The section crosses the road from Wall 62 in N. E. direction. It is composed by the following layers:

1. Surface layer.
2. Layer of dark earth, resting on the red lime-marl pavement of the road.
3. Filling layer of earth, gravel, and small stones down to the rock and supported by a terrace wall of rubble.

The filling and the pavement of the road abut against Wall 62 and are not cut through by it. This shows that the wall cannot have been built later than the pavement of the road was laid. This is of importance for the dating of the part of the palace formed by Rooms 85—93 (cf. pp. 193 f.).

Section XIII (Plan XI, 5).

The strata of Room 85 are recorded by this section which runs across the room from S. E. to N. W. The stratification shows the following sequence of the layers:

1. Surface layer.
2. Layer of brown earth mixed with clay and pieces of lime-mortar. The upper part of the layer contained much lime-mortar.
3. Layer of ash containing pieces of carbonized matter.
4. Thin, yellow-coloured layer of pulverized earth.
5. A layer of the same consistency as Layer 3.
6. Bottom layer, dark-greenish in colour, with pieces of charcoal, and containing some sand.

The horizontal stratification seems to indicate that the layers have infiltrated with water pouring through the opening of the fire-rooms of Walls 63 and 64 A—B: Layer 2 consists of remains of decomposed mud-bricks from the wall mixed with lime-mortar of the stone foundations. It is worthy of notice that the lime-mortar occurs almost exclusively in the upper part of the layer, which is in accordance with the natural sequence in time of the decomposition process of the walls: the upper brick-walls were decomposed before the decomposition of the stone foundations began. Layers 3, 5, and 6 are remains of fires lit in the fire-rooms of Walls 63 and 64 A—B. Layer 4 seems to represent remains of some organic material.

Sections XIV A—C (Plans XI, 6; XII, 1).

These sections are intended to show the sequence of strata in the N. E. part of the S. E. court (Room 83).

Section XIV A runs from Wall 72 in N. W. direction for a length of four metres. It has the following stratification:

1. Surface layer.
2. Horizontal layer of dark-coloured gravel.
3. Horizontal layer of light-coloured gravel.
4. Bottom layer of dark waste earth mixed with ash and full of potsherds.

The rock has been quarried for building-stones used in the walls of the palace and descends by cut steps marking the excised blocks. Layer 4 is evidently a filling layer thrown in the cavity of the quarry and serving as a levelling stratum for the floor of the court. Layers 2—3, as shown by Section XIV C, are alluvial layers brought there by the rains and accumulated on the floor-level of the court which thus is formed by the rammed surface of the filling of Layer 4.

Section XIV B runs from end of Section XIV A in N. E. direction to Wall 58. The stratification is composed of the following layers:

1. Surface layer.
2. Horizontal layer of dark-coloured gravel which in the N. E. part of the section has been washed away by the rains.
3. Horizontal layer of light-coloured gravel.
4. Bottom layer of red, sterile earth. This bottom layer is only represented in the N. E. part of the section where the rock slopes towards Wall 58.

Layers 1—3 are the same as in the previous section but Section XIV B differs from that in two respects: the rock has not been quarried and the bottom layer is of another kind. It is not a waste layer containing culture remains of ash and potsherds, but consists of the sterile, red earth which is found everywhere on Vouni below the earliest culture remains where these do not rest direct on the rock, and it thus represents the original earth which covered the rock before the place was inhabited. This original bottom earth was so deep within the area cut by this section that an artificial filling was not necessary for levelling the court.

Section XIV C runs parallel with the previous section, 4.50 m. N. W. of it, from Wall 58 to the cistern of the court. The stratification consists of the following layers:

1. Surface layer.
2. Horizontal layer of light-coloured gravel.
3. Bottom filling composed of superimposed layers of red and brown clay, ash, gravel, and sand. These layers are oblique and slope from Wall 58 but their upper part is cut horizontal on a level with the rock around the cistern.

It is thus evident that this filling forms a levelling layer for the floor in this part of the court, and corresponds therefore to Layer 4 of Section XIV A, though it is not of the homogeneous composition as that. Layer 2 corresponds to Layer 3 of the previous sections, while Layer 2 of those sections is missing in Section XIV C having been entirely washed away by the winter-rains, as a part of it was in Section XIV B. The relation of Layer 2 to the rock-floor and the cistern which is covered by this layer shows that it is a later alluvial layer brought by the winter-rains after the palace was abandoned.

Sections XV A—B (Plans XII, 2, 3).

The relation of the layers inside Room 84 to those of the S. E. court is illustrated by these sections.

Section XV A is an angular section running in the longitudinal axis of Room 84 from Wall

58 for a length of 1.75 m., then turning to the S. E., it crosses Wall 154 and extends to Section XIV C. The stratification inside Room 84 consists of the following layers:

1. Surface layer.
2. Layer of grey mud-brick earth.
3. Layer of reddish mud-brick earth mixed with sand.
4. Alternating streaks of ash, carbonized matter, and dark-green, burnt earth resting on a floor-level of rammed earth.
5. Layer of grey mud-brick earth mixed with small pieces of charcoal.
6. Earth and gravel, reddish in colour, with streaks of lime and containing a great quantity of potsherds.

Outside Wall 154 the stratification is in accordance with that of the adjoining part of Section XIV C, and consists of:

1. Surface layer.
2. Layer of light-coloured gravel.
3. Bottom filling of alternating layers of ash, carbonized matter, gravel, and sand.

This bottom filling has been dug through at the erection of Wall 154, which was shown by the existence of a foundation trench filled with disturbed earth, close to this wall.

Of the layers inside Room 84, Strata 2—3 are remains of decomposed mud-bricks fallen from the walls; Stratum 4 consists of accumulated waste of fires, alternating with successively raised floor-levels of rammed earth; Strata 5—6 are filling layers below the floor.

This bottom filling inside Room 84 thus corresponds to Layer 3 of the section outside this wall. It is, however, of different composition and abuts against Wall 154, while the bottom filling outside this wall is dug through by a foundation trench, as mentioned above. On the other hand, there is evidence that the layers, at least in part, contain the same waste material: pieces of the Red Figured amphora No. 9 were found both in the filling outside and inside Wall 154. This seems to indicate that the filling of the court outside Wall 154 originally covered the area later occupied by Room 84. At the erection of the walls of this room, the filling was first removed within the area of the room to be built; the foundation trench outside Wall 154 marks the limit of this cleared area; after the erection of the walls of Room 84 the filling was replaced below the floor of the room. This explains both the similar contents to the filling outside Wall 154, and the difference in stratification.

Section XV B runs from Wall 50 in S. E. direction through Room 84, parallel with Wall 153, crosses Wall 154 obliquely and continues for a length of 2.00 m. to the S. of that wall.

The upper part of the layers down to the floor-levels of Room 84 and the S. E. court had been removed when the section was drawn and only the bottom fillings are preserved. These correspond to those of Section XV A, and the foundation trench outside Wall 154 was clearly marked. Inside Room 84, the section cuts through a drainage channel built on a substructure of rubble. This channel runs from an outlet in Wall 147 to Room 85 (cf. p. 171).

Section XVI (Plan XII, 4).

This section cuts through the layers of Room 40 between Walls 65 and 124 and consists of the following strata:

1. Surface layer.
2. Fragments of grey mud-brick and red earth, resting on the cement floor of the room.
3. Layer of small and larger rubble, at the bottom merging into greyish earth.
4. Layer of dark-brown, sterile earth.
5. Layer of small rubble and pieces of lime-mortar.
6. Layer of dark-brown earth containing quantities of potsherds.
7. Bottom layer of dark-red, sterile earth.

Layer 2 above the floor is formed by decomposed mud-bricks, fallen from the walls. Layers 3—6 below the floor are superimposed filling strata of earth and waste material, and Layer 7 is the original, sterile bottom earth, covering the rock (cf. Section XIV). It is to be observed that the floor and the strata below the floor are cut through by a foundation trench, close to Wall 65, while they abut against Wall 124, indicating that the former was built later than the latter, and after the filling was heaped up (cf. p. 193).

Section XVII (Plan XIII, 1).

This is an angular section, cutting through the strata of Room 39 and running from Wall 124 to Wall 119 A. It shows the following stratification:

1. Surface layer.
2. Reddish layer of decomposed mud-bricks.
3. Horizontal layer of greenish earth.
4. Oblique layer of greyish earth, in part interrupted by a wedge-shaped piece of brown, sterile earth. The layer slopes towards the walls.
5. Oblique layer of the same earth as in Layer 3.
6. Oblique layer of grey earth and a quantity of rubble.
7. Horizontal bottom layer of brown, sterile earth.

The floor of the room was not preserved within the area of the section, but had lain on top of Layer 3. Below the floor-level there is a deep filling consisting of Layers 3—6 similar to that below the floor of Room 40, and a bottom layer of the original, sterile earth covering the rock. It is shown by the section that a part of this bottom earth was removed close to Wall 124 when this wall was founded, so that the bottom layer close to the wall is formed of the grey earth of Layer 6. That part of the bottom earth dug away was found higher up in the filling, where it reappears as a wedge-shaped piece of brown earth in Layer 4. On the other hand, this bottom earth abuts against Wall 119 A, which shows that at the erection of this wall the bottom earth was only dug away in line with the interior face of the wall.

Sections XVIII A—B (Plan XIII, 2).

These two sections cut through the strata below the floor of Room 7 A, at right angles to each other, Section XVIII A running from Wall 119 B in S. W. direction for a length

VOUNI

The palace

Section XVII

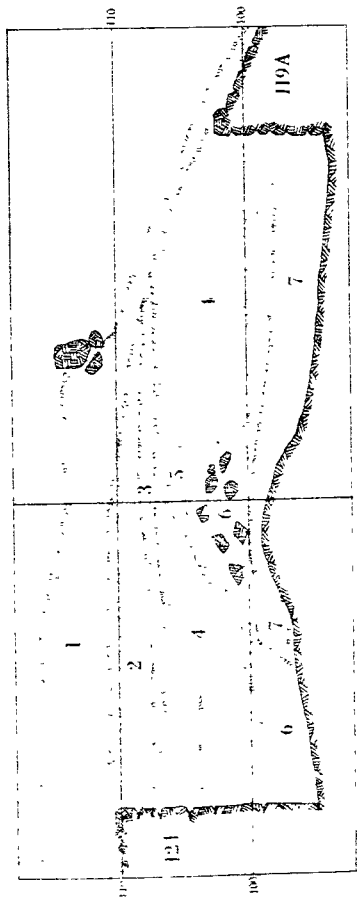

1

Section XVIII

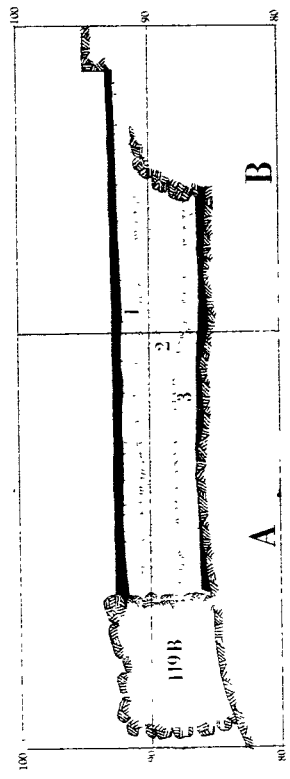

2

Section XIX

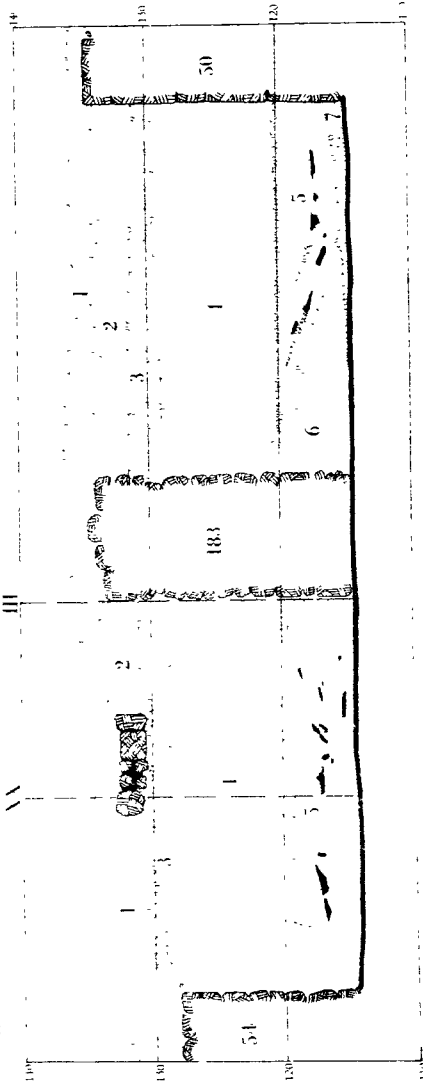

3

Section XX

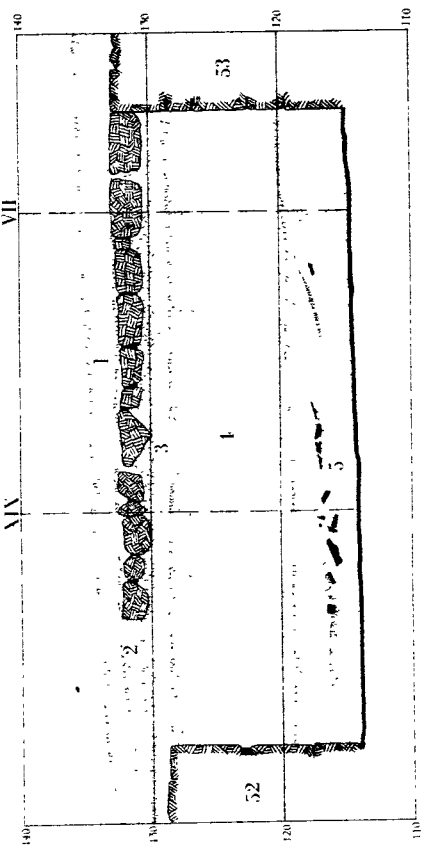

4

Section XXI

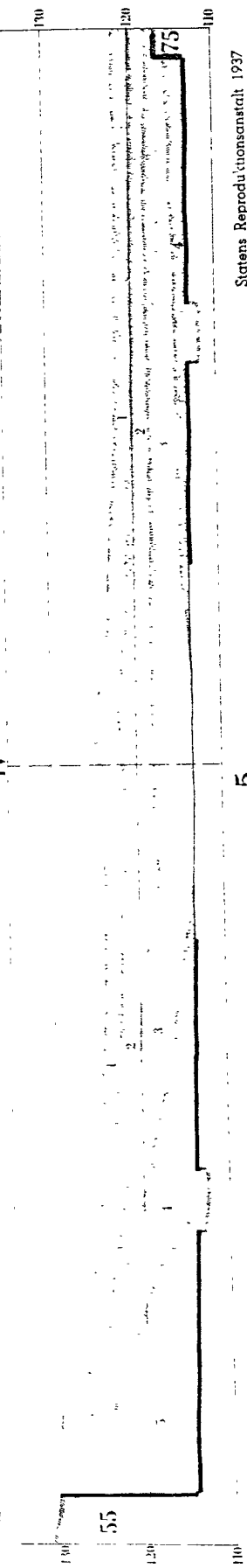

5

of 2.00 m. and Section XVIII B from the S. E. end of Section XVIII A in S. W. direction to the staircase leading from Room 7 A to Room 37.

The stratification is the same in the sections and is composed of three layers:

1. Layer of red earth serving as substructure for the floor of Room 7 A.
2. Buff-coloured layer of earth.
3. Layer of dark earth resting on the cemented rock-floor of the road running along the N. E. exterior wall of the palace and widened to a small, open place in the angle between Rooms 36 and 37. The stratification shows that this open place was later occupied by Room 7 A and the potsherds found in Layer 3 of the filling below the floor of this room are important for the dating of this part of the palace architecture (cf. p. 192).

Section XIX (Plan XIII, 3).

This section cuts through the strata of Rooms 43 and 44, running in S. E. direction from Wall 54 to Wall 50. The layers in Room 44 have the following stratification:

1. Surface layer.
2. Layer of lime-earth.
3. Layer of decomposed, red mud-bricks.
4. Layer of decomposed, grey and white mud-bricks.
5. Layer of pieces of cement, gravel, and reddish lime-marl.

Layer 5 is apparently the remains of the floor of the upper story which has collapsed. Layers 3 and 4 are decomposed brick walls. The grey mud-bricks (Layer 4), which have fallen first were consequently used higher up in the wall than the red mud-bricks (Layer 3), which are accumulated above. This indicates that the walls of the upper story were built of grey and white mud-bricks and those of the ground-floor of red mud-bricks. It is worthy of notice that the red layer of mud-bricks is much thinner (about 20 cm.), than that of grey and white mud-bricks (about 90 cm.), which is in accordance with the fact that the walls of the upper story were built entirely of mud-bricks while those of the ground-floor were almost entirely of stone. Layer 2 is formed by lime-mortar and weathered limestone material from the stone walls, the upper part of which began to crumble after the collapse of the brick walls.

This part of the section crosses a stone foundation built of a single row of rubble and running parallel with Wall 183. It is founded in the upper part of Layer 3 and is embedded in Layer 2. It was therefore built after the brick walls had collapsed, but before the stone walls began to crumble, i. e., not a very long time after the destruction of the palace. The purpose of the foundation is entirely unknown.

The stratification of the layers in Room 43 differs from that of Room 44 in one important respect: below Layer 5 there is a wedge-shaped stratum of red sand and earth abutting against Wall 183 and sloping to the middle of the room (Layer 6); below that again is a thin bottom layer (Layer 7) of fine, drifted sand, sloping from Wall 50 to the middle of the room, i. e., in the opposite direction to Layer 6.

Layers 6—7 consist of the red earth and sand which form the soil on the rock of Vouni



Fig. 115. Vouni. The palace. Section through the floors of Room 57.

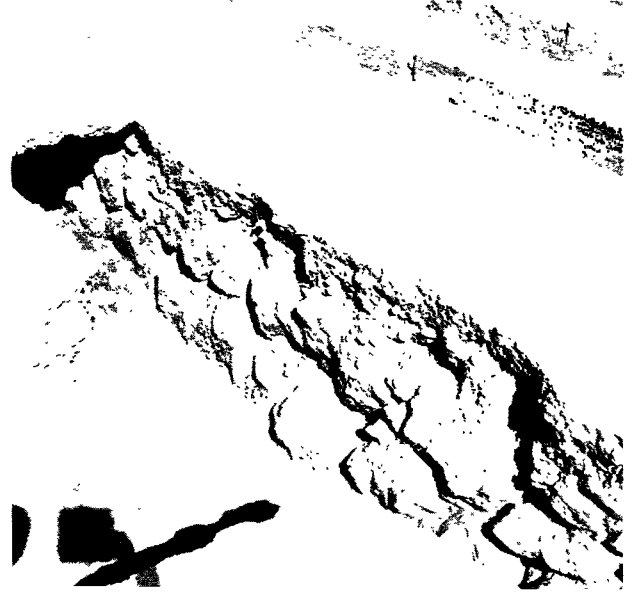

Fig. 116. Vouni. The palace. Section below the floor of Room 7 A.

and the neighbourhood. They must have accumulated on the floor before the roof (Layer 5) collapsed. As there are no traces of windows in the walls these layers must have infiltrated through an opening in the floor of the upper story, probably driven there by the wind: such red earth and sand fills the air of Vouni, even nowadays when a strong wind blows. An opening of this kind communicating between the upper story and the ground-floor seems to be best explained by assuming the existence of a wooden staircase along Wall 183; the only way by which one could enter Room 43 after the erection of Wall 183.

It seems possible that there was a similar staircase in Room 44, too, as otherwise there would be no entrance to this room either after the erection of Wall 183. There is, however, no stratigraphic evidence of such a wooden staircase in this room.

Section XX (Plan XIII, 4).

This section runs across Room 44 from Wall 53 to Wall 52 crossing Section XIX. Its stratification is the same as that of the crossed part of Section XIX. The section shows the extension of the post-palatial stone foundation which runs parallel to Wall 183, and is founded in the debris of Layer 3 (cf. above).

Sections XXI—XXVII (Plans XIII, 5; XIV, 1).

These sections run across the central court from S. E. to N. W., Section XXI from Wall 55 to Wall 75 and Section XXII from the blocked-up door of Room 44 to the doorway of Room 36. Their importance lies in the fact that they show us the brick-wall construction of the rooms around the central court and they support the evidence of Sections XIX—XX in this respect.



Fig. 117. Vouni. The palace. Layers below the floor of Room 39.



Fig. 118. Vouni. The palace. The filling of the tank-cistern in the central court.

Section XXI has the following stratification:

1. Surface layer.
2. Red mud-brick layer.
3. Grey-white mud-brick layer
4. A—B. Red mud-brick layer.
5. Grey-white mud-brick layer.

All the strata below the surface layer thus consist of alternating layers of decomposed red and grey-white mud-bricks, fallen from the walls of the rooms around the central court. Layers 4 A—5, as shown by the section, are formed by mud-bricks from the rooms S. E. of the central court. Layer 4 B abutting against Wall 75 is composed of mud-brick earth from walls of the rooms N. W. of the central court as the layer slopes from Wall 75 to the middle of the court. Layers 2—3 belong to the walls N. E. of the court as they slope from that direction which, however, cannot be shown by the section. It is thus evident that the brick walls of the rooms S. E. and N. E. are represented by a lower layer of grey-white mud-bricks and an upper layer of red mud-bricks, while the brick-walls of the rooms N. W. of the court are only represented by a single layer of red mud-bricks. If we compare this with the mud-brick stratification of Sections XIX—XX it is evident that the stratifications agree: the layers of grey-white mud-brick were always found below those of red mud-brick, and we are therefore justified in drawing the conclusion that the brick walls of the upper story were built of grey-white mud-brick, while those of the ground-floor were built of red mud-brick. As there is only one layer of red mud-brick belonging to the walls of the rooms N. W. of the court, this shows that the brick walls of this upper story did not tumble into the central court. Apparently they fell to the N. and N. W., and their remains have been washed away

by the winter-rains together with a great part of the floors and stone walls of these rooms (cf. p. 151). As the mud-brick layers of the rooms N. E. of the court are stratified on top of those belonging to the rooms S. E. and N. W. of the court, it can be seen that the walls of the latter rooms were destroyed first.

Finally it is to be observed that the layers of mud-brick are intact above the channels for the missing slabs in the stylobate, which proves that the slabs were removed before the mud-brick walls collapsed, a short time after the palace was abandoned.

The stratification of Section XXII agrees with that of Section XXI, except that the layer corresponding to Layer 2 of Section XXI is missing: it has been washed down the slope by the rains. The section cuts through the capital (Object Register No. 290) of one of the columns of the peristyle. The capital rests on the red mud-brick earth of the walls S. E. of the court, and is embedded in the grey-white mud-brick earth of the walls N. E. of the court, which indicates that the column of the capital belonged to the N. E. side of the peristyle; and we may therefore with great certainty attribute the capital to the column in the middle of the N. E. stylobate, near whose place it was found.

Section XXIII (Plan XIV, 2).

The stratification around and in the filled hole marking the place of a wooden stand for hoisting water from the cistern (cf. p. 166) is shown by this section. We see the edges of the cistern, the top of its filling, and the covering floor of white lime-marl (cf. p. 152). The rectangular hole for the wooden stand is sunk in the upper part of the filling to a depth of c. 0.25 m. below the floor-level, and the floor of lime-marl abuts against the earth of the hole. The hole was filled with dark earth of mouldered, organic matter.

Section XXIV (Plan XIV, 3).

In the cavity below the floor of Room 13 (cf. p. 148) and above the same, quantities of potsherds of chronological importance were found. The strata of the filling in the cavity and on the floor are recorded by this section, showing the following sequence:

1. Surface layer.
2. Thick layer of buff-coloured mud-brick earth, consisting of a mixture of red and grey-white mud-bricks.
3. Layer of buff-coloured earth containing waste material, potsherds, etc. and forming a convex mound.
4. Layers of superimposed streaks of hard, rammed earth, greenish and brown in colour.
5. Dark layer of ash, carbonized matter, and other waste material.
6. Bottom layer of yellow sand and gravel, containing only a few potsherds.

Layer 6 forms the original filling of the cavity on which a filling of waste material was thrown in (Layer 5). This filling was then covered with a floor of rammed earth (Layer 4) which has sunk in the middle and interior parts of the cavity and was levelled with a layer of earth and waste material swept away in the sunk part of the floor (Layer 3). Finally,

VOUNI
The palace

Section XXII

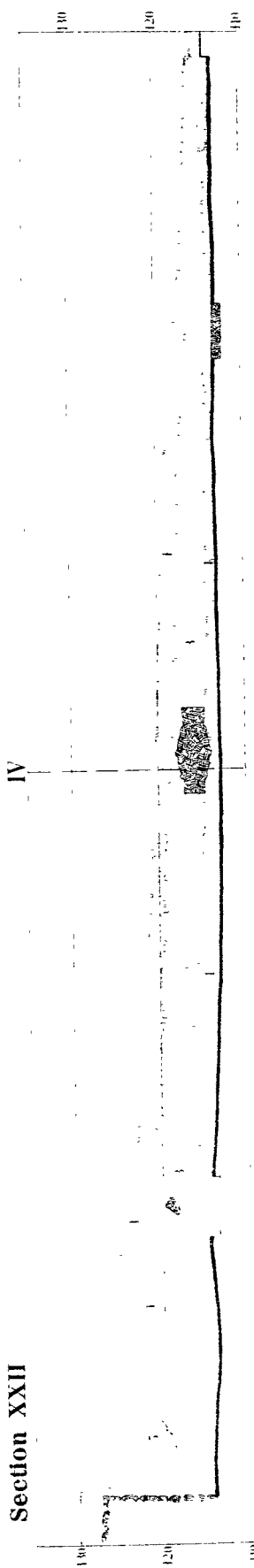

Section XXIII

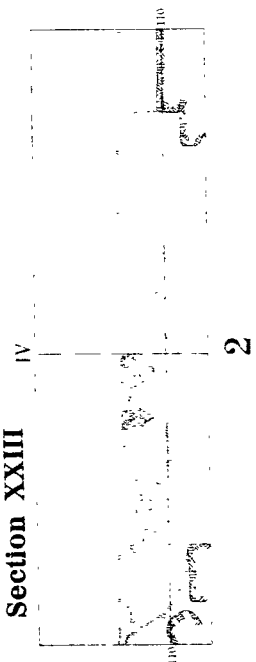

Section XXIV

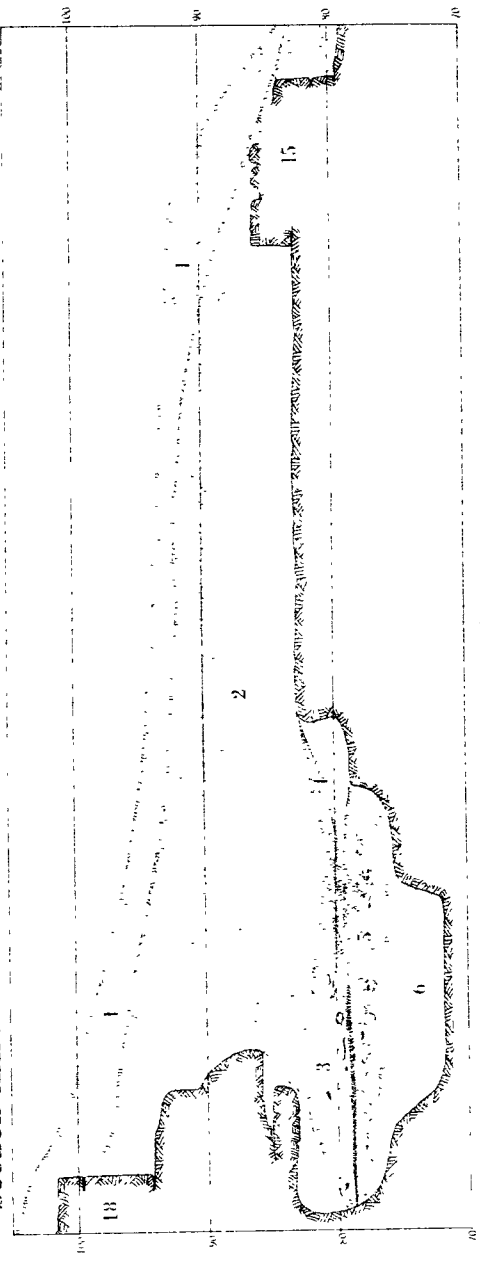

Section XXV

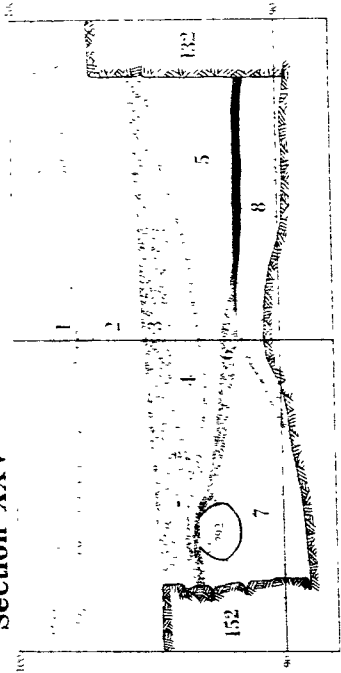

Section XXVI

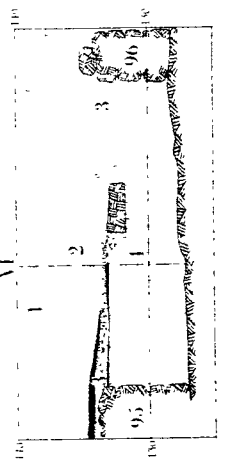

when the palace was destroyed the earth of the adjoining mud-brick walls covered the room (Layer 2).

Section XXV (Plan XIV, 4).

This section shows the stratification in Room 59, at the place where the treasure of silver and gold was found (Obj. Register No. 292). The section runs from Wall 132 in S. E. direction to the doorway leading to Room 60, and turns there at right angles in S. W. direction to Wall 152. The stratification consists of the following layers:

1. Surface layer.
2. Layer of red-brown mud-brick earth.
3. Dark layer of carbonized matter.
4. Grey layer of ash.
5. Layer of grey-white mud-brick earth.
6. Dark layer of carbonized matter.
- 7—8. Bottom layers of sterile earth, light in colour with lumps of red earth (Layer 7) or dark-red (Layer 8).

Layers 5 and 6 rest on the floor-level which is marked by a layer of lime-marl close by the doorway leading to Room 60 but in the remaining part of the room consisting of the sloping surface of the bottom filling. The terracotta jar containing the treasure had been placed in a shallow cavity dug out of the bottom filling, and with its bottom on a level with the preserved lime-marl floor, and was covered by the layers above the floor.

It can be seen (cf. above, pp. 162 f.) that Room 59 was a dark closet below the staircase leading to the upper story. The jar had evidently been hidden there at the time of the destruction of the palace, and was quickly covered with the burnt remains of the wooden staircase (Layer 6), the earth of the grey-white mud-brick walls of the upper story, other burnt remains (Layers 3—4) and the earth of the red mud-brick walls of the ground-floor. In this way the treasure was hidden and was not found again after the destruction of the palace; either the person who placed it there forgot the hiding-place, or was killed by the conquering enemies.

Section XXVI (Plan XIV, 5).

This is a transverse section through Room 75, running between Walls 95 and 96 across the cooking-place of the room.

The stratification consists of the following layers:

1. Surface layer.
2. Layer of brown-grey mud-brick earth which above Wall 95 rests on the scanty remains of the upper floor of Room 75+77.
3. Layer of ash and carbonized matter around and above the bordering stones of the cooking-place. This layer rests on the lower floor of rammed earth which abuts against Wall 95.
4. Bottom filling of red-brown earth below the lower floor.

Section XXVII (Plan XV, 1).

This section illustrates the layers of Room 66 from about 2.00 m. N. E. of Wall 145, cuts that wall, and runs across Room 69 to Wall 86.

The stratification consists of the following layers:

1. Surface layer.
2. Layer of red-brown earth of decomposed mud-bricks. This layer rests on a floor of red lime-marl, which abuts against Walls 86 and 145. Layers 1—2 are only included in the part of the section outside Wall 145 and the floor of red lime-marl in Room 69 is on a lower level than in Room 66.
3. Filling layer of brown and dark earth mixed with waste material. In Room 66 this layer rests on a lower floor-level of rammed earth. Close to Wall 145 and in Room 69 this floor-level and the upper part of Layer 4 are cut through by a pit filled with the earth of Layer 3.
4. Deep filling of similar earth and waste material, resting on the rock.

In Room 66 the rock descends by cut steps of the same kind as below the floor-level of the S. E. court (Section XIV A), showing that it has been quarried for building-stones. Layer 4 was then thrown in as filling of this quarry, levelling the place for a floor of rammed earth. Some time later the S. W. part of this floor together with the top of Layer 4 was dug away and within this sunk area Room 69 was built. A new filling of earth, Layer 3, was thrown on top of the floor-level of rammed earth in Room 66 and in the pit dug out for Room 69. The upper floor of red lime-marl was laid on top of this filling. Finally, the mud-brick walls of Room 69 collapsed and formed Layer 2 on top of this upper floor.

Sections XXVIII—XXX (Plan XV, 2—4).

These sections illustrate the stratification in the main temenos; Section XXVIII runs through Room 122, from Wall 170 to the doorway in its E. corner and down the staircase; Section XXIX runs from the middle of Room 123 across Wall 173 and Room 128; Section XXX crosses Room 129 from Wall 173 to its open front side. The stratification of Sections XXVIII and XXX show the same sequence of layers:

1. Surface layer.
2. Layer of brown earth of decomposed mud-bricks.
3. Bottom layer of red, pulverized culture earth: the typical earth containing finds of sculpture, and represented in the temenos and the cult-chapels within the areas where sculptures were found.

The stratification of Section XXIX is more varied and differs in Rooms 123 and 128. The surface layer and second layer of brown earth are the same all over the section and correspond to Layers 1—2 in the previous sections.

In Room 123 there is a third layer of ash and carbonized matter from the burnt sacrifices which occurs around the altar close to the section. Below that there is a bottom layer of sterile, red earth filling the irregularities of the rock-floor.

Section XXVII

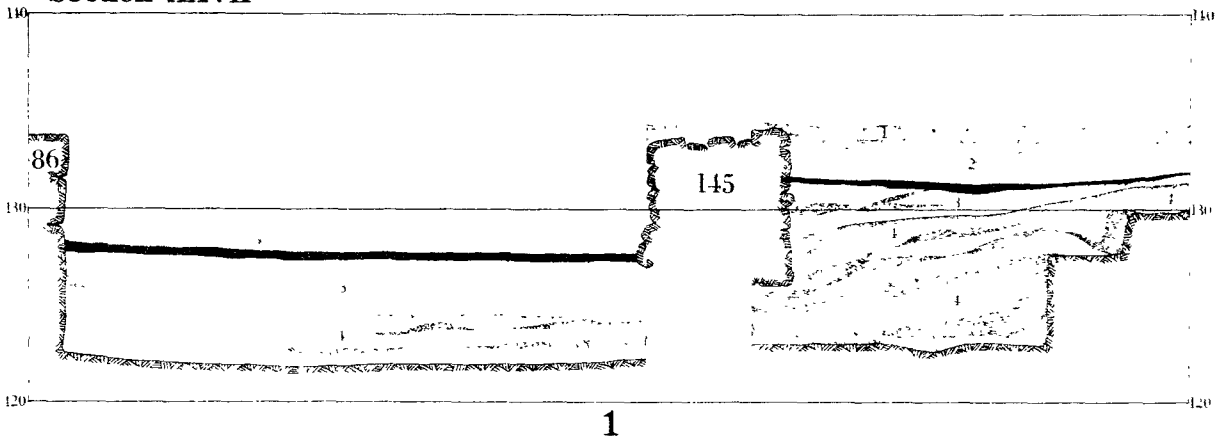

Section XXVIII

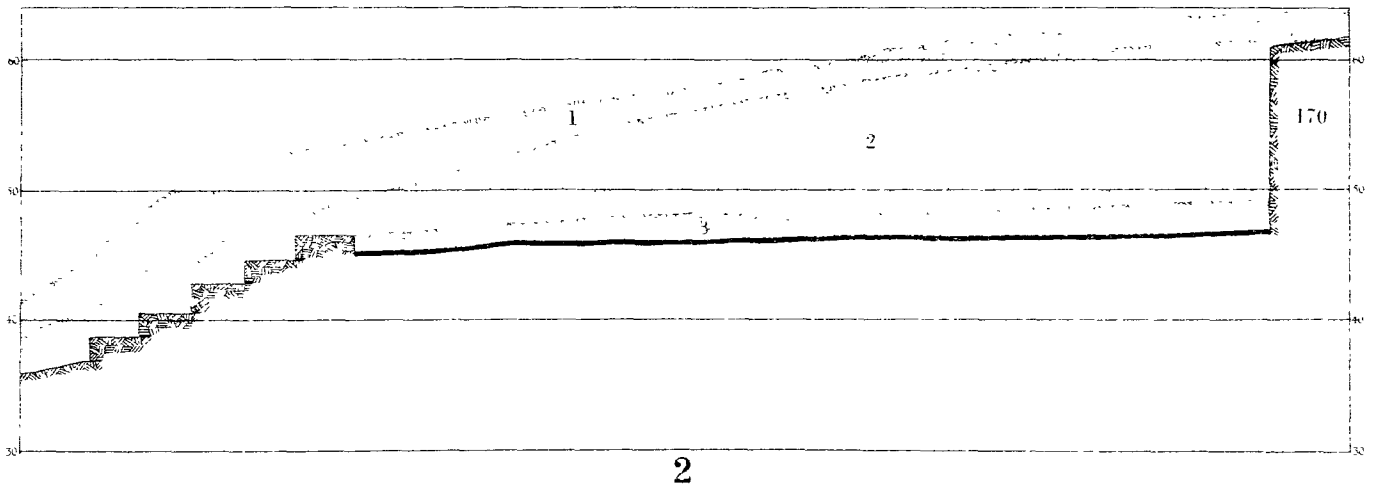

Section XXIX

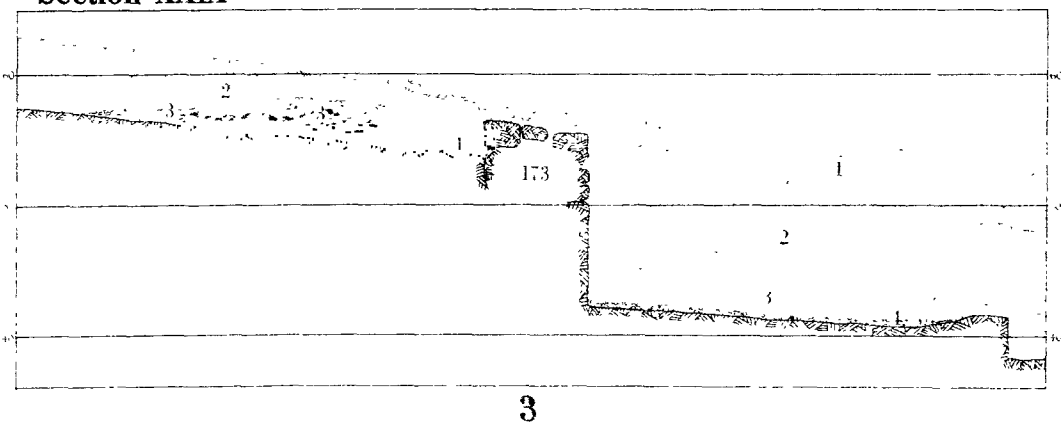

Section XXX

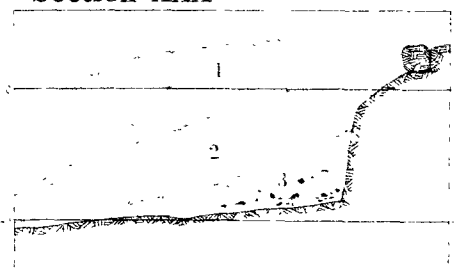

In Room 128 there is a third layer of culture earth corresponding to Layer 3 of the previous sections and a bottom layer of ash and carbonized matter.

ARCHITECTURAL ANALYSIS (FIGS. 119, 120).

An analysis of the architecture shows that the palace was built in four periods and that its original plan was essentially changed during this successive building activity.

This analysis is based upon an examination of the structural data mentioned in the description of the architectural elements, upon the stratigraphic evidence, the relation of the structures to the floors, and upon the dating material, found on and below the floors. In the palace this dating material consists of potsherds and in the surrounding sanctuaries the sculptures form a supplementary, chronological evidence. A statistical list of the potsherds is given in the chapter on Absolute Chronology, pp. 280 ff. It can be seen from this list, that the pottery is divided in four groups, corresponding to the four building periods: the first period is characterized by pottery almost exclusively of Type V; the second period by a mixture of Types V and VI; the third period by almost exclusively Type VI; and the fourth period by a mixture of Types VI and VII.

We begin the analysis in Rooms 51, 52, 53. Below the floors of Rooms 51 and 52 sherds of Type V: White Painted V, Black-on-Red III (V), Red Slip III (V), Plain White V, "Ionian Cup" fabric, and Black Glazed Greek pottery (pp. 280 f.), were found; this part of the palace, consequently, belongs to the 1st building period. Walls 1—4 are therefore to be assigned to that period. Wall 73 is, however, certainly built in a later period which is evident from the following facts. The construction of this wall differs from that of the walls mentioned above: while these are single-faced shell-walls (Type 1) Wall 73 is a box-wall (Type 6, Class, D). Moreover it is not bonded to any of the adjoining walls 1 and 2. The construction of these latter walls (cf. p. 113) shows that no other wall, later demolished, has connected them because the socle of these walls is sunk in a shallow channel cut in the rock, while Wall 73 is founded direct on the rock. If an earlier wall of the same construction as Walls 1 and 2 had existed there such a channel would have been cut in the rock for its socle. We are therefore justified in concluding that the S. W. side of Room 53 was originally open and that Wall 73 was built on a later occasion. This is furthermore supported by the fact that the floors of Rooms 51 and 52 rest on a substructure of red cement (cf. p. 152), as all the floors of the adjoining rooms, while this substructure is missing in Room 53. This difference in structure indicates that the floor of this room was not laid at the same time as the floors of Rooms 51 and 52. The floor of Room 53 is not cut through by Wall 73, but abuts against it. The floor and the wall are therefore contemporary, or the floor is later than the wall. The latter is improbable from the fact, that in such a case, the floor of Room 53 would have consisted of the rough rock, even some time after the room was closed. This would be quite exceptional in the palace where no closed rooms, except the store-rooms, have rock-floors. If therefore the floor and the wall are contemporary, it follows that this wall was built later than Walls 1 and 2.

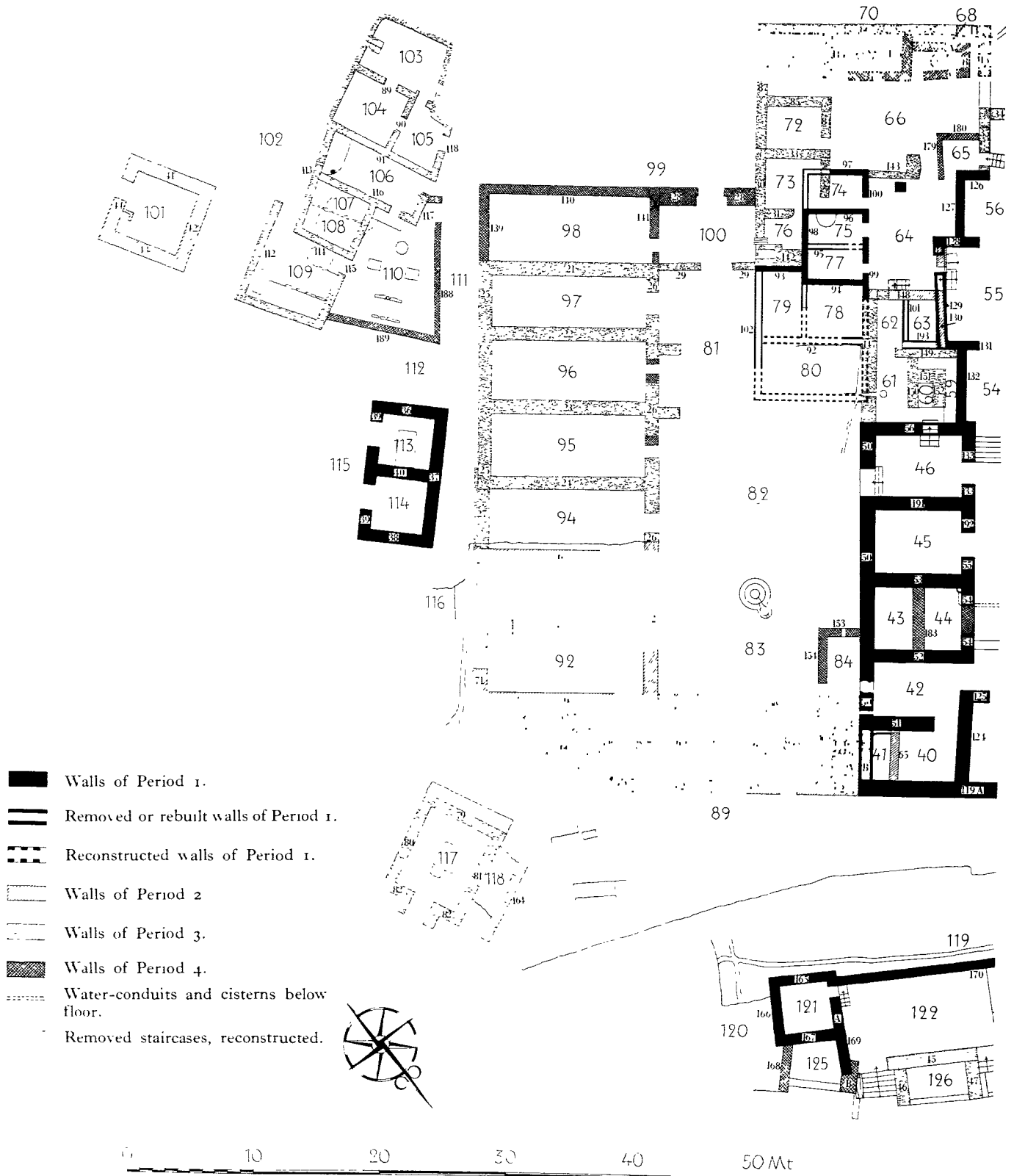
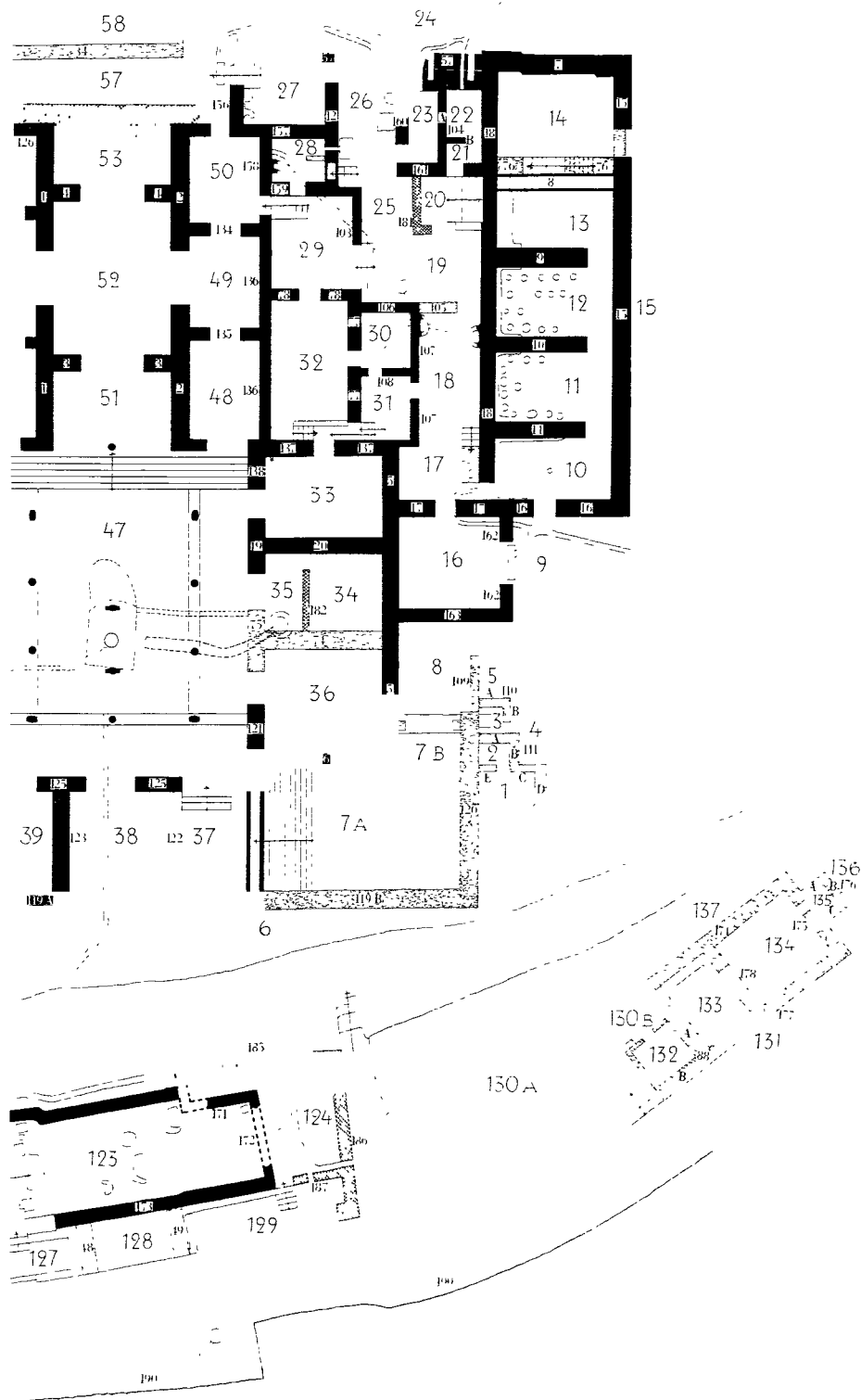

Fig. 119. Vouni. The palace.



Analytical Plan.

Along Wall 73, an exterior wall of rubble (Wall 155) is built. This wall must be later than Wall 73, because it is founded on top of the lower floor in Room 57, while this floor abuts against Wall 73. Between the two floors and below the lowermost a single sherd of White Painted V and many sherds of White Painted VI, Plain White VI, and Black Glazed Greek (p. 282) were found. Wall 73 seems therefore to belong to the 3rd building period and the Wall 155 to the 4th building period.

As the floor of Room 53, too, abuts against Wall 73, dateable sherds below this floor would contribute to the solution of the question, but unfortunately no such sherds were found below the floor. A sure proof that the wall belongs to the 3rd building period is, however, given by the incontestable dating of the entrance formed by Room 7 A + B. This entrance belongs to the 3rd building period and, as will be shown below, p. 192, the foundation of this entrance and the erection of the innermost Wall 73 are architecturally connected with each other.

The dating of Wall 73 to the 3rd building period assigns Wall 34 to the same period because the lowermost floor of Room 57, which abuts against the former wall, abuts against the latter, too. It is thus evident that Room 53 was a vestibule with open front to the S. W. during the 1st and 2nd building periods. In other words, here was an entrance during these periods, and, as will be shown, the main entrance of the palace.

We continue the analysis. Rooms 48, 49, 50, and 54, 55, 56 naturally belong to the 1st building period, as they form a coherent structure with Rooms 51, 52, 53. Wall 130, however, has replaced Wall 129 in a later period (cf. p. 140).

The central court (Room 47) belongs to the 1st period, — it forms the nucleus of the palace, and, in fact, below the floor of the court were found sherds of Type V: White Painted V, Black-on-Red III (V), Plain White V (cf. p. 280). In the deep filling below the floors of Rooms 37, 38, 39, 40 (cf. Sections XVI—XVII, p. 180) the same kind of potsherds was found in great number: White Painted and Bichrome V, Black-on-Red III (V), Bichrome Red II (V), Red Slip III (V), "Ionian Cup" fabric, Black Figured Greek (cf. p. 281). Some rearrangements, however, of the original conditions in the central court and the rooms around it have taken place. The tank-cistern in the central court, and the well-cistern in Room 35 belong to the original structure. On a later occasion the tank-cistern was transformed into the "bottle"-cistern, as described above, p. 165,: the part of the tank-cistern unoccupied by the "bottle"-cistern was filled up to the floor-level with small chips of limestone and gravel, the well-cistern in Room 35 was filled with a greenish, sandy earth, and the rock-cut tunnel between these cisterns was blocked up. Potsherds of Type VI on the bottom of both cisterns show that this rearrangement took place in the 3rd building period. At the same time Walls 74 and 75, which are bonded to each other, were built. Wall 74 runs across a part of the well-cistern and must therefore be later than the cistern. On the other hand, it is evident that the erection of the wall cannot be later than the filling up of the cistern, because the floor of Room 35 which covers the filled-up cistern abuts against the wall and is not cut through by it. Wall 182 is founded upon the floor and is not bonded to Wall 74; it seems therefore to be later than that wall and belongs to the 4th building period.

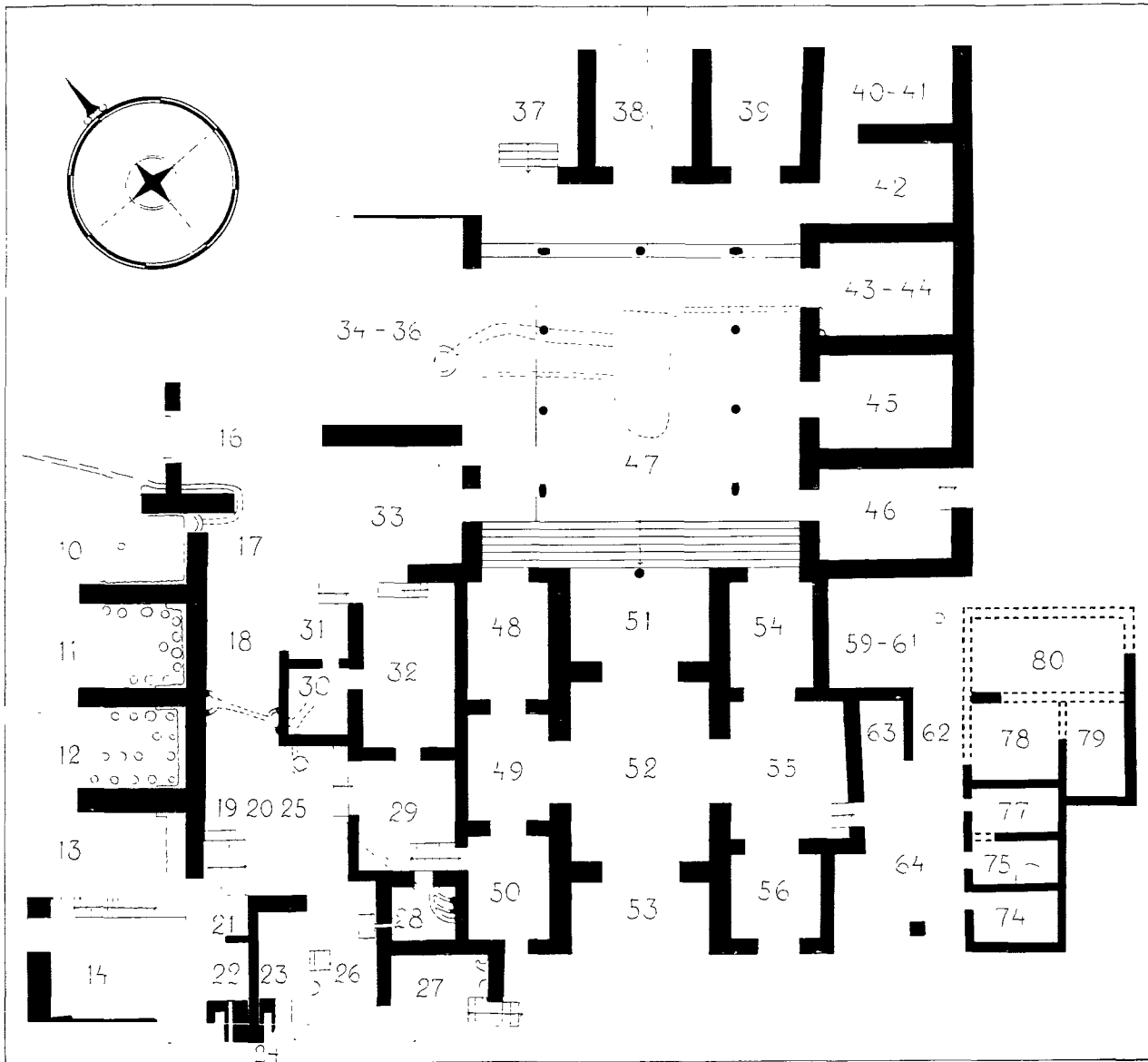

Fig. 120. Vouni. The palace. Plan of 1st period.

A floor of white lime-marl was laid on top of the filled-up part of the tank-cistern in the central court, and in this floor, N. E. of the opening of the "bottle"-cistern, was found the rectangular hole for one of the wooden posts on which the wooden beam, by which the water was hoisted, rested. The wooden posts thus, belong to the 3rd building period while the stelae of stone which were to replace them were evidently among the latest works carried out in the palace, as they were never finished.

In Room 44, too, later rearrangements have changed the original conditions. The doorway between Room 44 and the central court was blocked up with rubble and roughly dressed blocks and a wall of rubble (Wall 183) was built across the original Room 43-44, dividing it into two small rooms. The wall is founded upon the floor. These rearrangements were

most probably carried out in connexion with the other rebuildings in the central court and the rooms around it, as mentioned above, either in the 3rd or 4th building period. To which of these periods we should assign the building operations in Room 43—44 can not be proved with absolute certainty, so far as I can see. Only the careless structure of the wall which is characteristic of rubble walls of the 4th building period and the fact that the wall is founded upon the floor which also is characteristic of some of the walls of that period, affords an indication that Wall 183 and the blocked up doorway of Room 43—44 are to be assigned to the 4th building period.

We continue the analysis with an examination of Room 7 A—B. If we examine the stone foundation of Walls 119 A and B, we find that there is no clear break in the masonry between these walls opposite Wall 121, but it seems that the wall has been botched there, i. e., Wall 119 B seems to have been added to Wall 119 A on a later occasion. An examination of the earth-filling below the floor of Room 7 A+B shows that this must have been the case, because this room evidently belongs to the 3rd period and Rooms 37—41 to the 1st period: while the earth-filling below the floors of Rooms 37—41 contained a great number of potsherds of the beginning of the 1st period (cf. p. 281) a number of White Painted V sherds and a majority of White Painted VI and Red Slip IV (VI) were found in the filling below the floor of Room 7 A (cf. p. 282). Furthermore the rock, on which this filling rested, was levelled and partly covered with lime-concrete. This levelled rock is a continuation of the road running along the N. E. exterior wall of the palace. This road, consequently, has been almost altogether occupied by Room 7 A—B in this place. The road was made in the 2nd period (cf. pp. 193 f.). It is thus evident that Room 7 A—B must be later than that period. On the other hand it cannot be so late as the 4th period, both on account of the potsherds found in the filling and the architectural connexion of Room 7 A+B with Wall 73: Room 7 A—B forms a main entrance of the palace and it must be assumed that this new entrance was built when the earlier entrance was blocked up by Wall 73. We know that this wall must be earlier than the 4th period (cf. p. 190) and Room 7 A+B must be later than the 2nd period, as was shown above. Consequently, both Room 7 A+B and Wall 73 belong to the 3rd period.

The walls of Rooms 1—5 are of another construction than Wall 120; they are of Type 11 while Wall 120 is of Type 12. The first mentioned walls may be later or contemporary with the last mentioned and they are therefore to be assigned either to the 3rd or the 4th period, but probably, the 3rd period, as no safely dated walls of Type 11 can be assigned to the 4th period.

We now proceed to an analysis of the N. E. part of the palace. Wall 64 B is later than Wall 64 A. This is evident from the fact that Wall 64 B is founded on the floor of stone slabs in Room 41, while this floor abuts against Wall 64 A. By removing some stone slabs of the floor on which Wall 64 B is founded it was found that there is an earlier wall below the floor. This wall is a continuation of Wall 50 and belongs therefore to the 1st building period. Wall 64 A is built along the S. E. face of this wall and is not bonded to the same. It is therefore likely to have been added later, though not necessarily

in a later building period. That the wall in question belongs to the 2nd building period can, however, be proved in the following way.

Wall 65 belongs to the 2nd building period, because, the original filling below the floor of Room 40 was dug through at the erection of this wall and in this disturbed filling potsherds of the 2nd period (a majority of Type V and a minority of Type VI) were found (cf. Section XVI, p. 180 and Statistical list of potsherds, p. 281), while potsherds of Type V, of the same kind as found everywhere below the floors of the 1st building period, were found in the original filling (cf. p. 281). As the Wall 50 belongs to the 1st period (cf. above), it is evident that Room 40 during this period was limited by this wall to the S. E. In the 2nd period this wall was demolished and the filling in the S. E. part of the room was dug away to a level of about 0.95 m. below the original floor-level; Wall 65 was built and separated the new rooms 40 and 41; Wall 64 A was built along the demolished part of Wall 50 and the floor of stone slabs was laid on top of this wall in the new room 41, between Wall 65 and Wall 64 A; as the latter was built contemporarily with the laying of the floor of stone slabs in Room 41 and the erection of Wall 65, which can be assigned to the 2nd period, it is evident that Wall 64 A, too, belongs to the same period.

Furthermore, Wall 64 A is bonded into Wall 58, which forms part of the coherent complex of Rooms 86 - 88, 92, 93. Below the floors of Rooms 86 - 88 a few and rather insignificant sherds were found but below the floor of Room 92 characteristic sherds of the 2nd building period (a majority of Type V and a minority of Type VI, cf. p. 281) were discovered in considerable quantities. This affords another proof that Wall 64 A belongs to the 2nd building period.

It remains to date Wall 64 B. We remember that the wall is founded on the floor of stone slabs in Room 41 and we may therefore infer that it was built after that this floor was laid. The floor can be assigned to the 2nd period, as shown above, and the wall must therefore belong either to the 3rd or the 4th building period, to which of these periods cannot be decided with absolute certainty: on account of the fact that the heating room of the palace bath was considerably enlarged by the erection of this wall, I am most inclined to assign the wall to the 3rd building period, as it cannot organically be included in the minor additions and alterations which characterize the 4th building period.

The complex of Rooms 85—88, 92—93 belongs to the 2nd period, as shown above. As regards Room 91, it seems that this room was built at the same time though its walls are not bonded to Walls 59 and 70. It is, however, to be observed that Wall 59 is founded on a socle which ends at Wall 66. This socle ought to have continued to Wall 70, if the S. W. part of Wall 59 once had been a visible, exterior wall. It is therefore to be assumed that Room 91 belongs to the same building period as the complex of Rooms 85—88, 92—93; although, on account of the small size of the room, it was not considered necessary to bond its walls to the adjoining ones.

A further corroboration that the complex of Rooms 85—93 belongs to the 2nd building period is given by the relation of Rooms 85—88 to the road running along the N. E. exterior wall of the palace. The filling substructure of the road (cf. Section XII, p. 177) and its pa-

vement abut against the walls of the rooms and cannot therefore be earlier than these. The potsherds found in the filling substructure consist of a mixture of Types V and VI, with a majority of Type V and a minority of Type VI, i. e., the group of pottery characteristic of the 2nd period, which shows that the road and Rooms 85—88 are contemporary.

The cistern in the S. E. courtyard (Room 83) which was fed with water collected on the roofs of the rooms mentioned above is naturally to be assigned to the 2nd period, too.

This complex of rooms thus dated has later been subject to some minor rebuildings: the doorways between Rooms 87 and 88 and the S. E. court have been blocked up, as well as the doorway between Rooms 92 and 93, and the exterior doorway of Room 93. At the same time as these doorways in Room 93 were blocked up, the whole room was filled with debris of chipped stones of the same kind as the filling of the tank-cistern in the central court. This indication that these rebuildings were carried out in the 3rd period, is corroborated by the fact that the S. E. court was definitely levelled in that period (cf. below). The door between Room 88 and the S. E. court must have been blocked up in connexion with this levelling of the court because Wall 58, with the blocked-up door, serves as a support of the deep filling of earth below the floor-level of the court.

We continue the analysis. Rooms 94—97 which form a coherent complex were built in the 3rd period. They are likely to be later than Rooms 92—93 as their walls are not bonded to those of these rooms. Furthermore below the floor of Room 95, potsherds of the 3rd period were found (White Painted VI, Plain White VI, and Black Glazed Greek, cf. p. 282).

Wall 29 belongs to the same period though it is not bonded to Wall 26, because in this wall was the exterior entrance to the S. E. court which was closed on all the four sides or, in other words, was formed by the erection of this wall and those of Rooms 94—97, and this can be proved to have taken place in the 3rd period from the finds of sherds of Type VI below the floor of Room 95 (cf. above) and from the following facts. The N. E. part of the court, close by Wall 58, where the rock slopes steeply, had to be filled in with debris of earth, gravel and waste material, as shown by Sections XIV A—C, in order to obtain a level surface for the court, and in this filling below the floor-level, potsherds, characteristic of the 3rd period, were found (a minority of Type V and a majority of Type VI, cf. p. 282), together with sherds of the "Ionian Cup" fabric, Black Figured and early Red Figured pottery, among which fragments of a Red Figured amphora, described in the Obj. Register, No. 9; this can be assigned to c. 460 B. C., and is therefore entirely in accordance with the evidence of the Cypriote pottery found in the filling (cf. *Absolute Chronology*, p. 285).

The S. E. court was thus laid out in the 3rd period. Room 84, on the other hand, which is built in the S. corner of the court was built after the levelling of the court, because its walls cut through the filling as shown by Sections XV A—B. Room 84 should therefore be assigned to the 4th building period.

The walls of Room 98 are not bonded to those of Room 97 and, moreover, are of quite another construction: while the walls of Room 98 are built of rubble (Type 14), those of Room 97, as well as the adjoining rooms 94—96, are ashlar walls of alternating orthostates and horizontal blocks placed lengthways (Type 4). Furthermore, the types of floor are

different in Room 98, where the floors consist of cemented, levelled rock, and in Rooms 95—97 where it consists of red lime-marl as a filling for the irregularities in the rock. All these structural differences indicate that Room 98 is a later addition, i. e., that it was built in the 4th period.

Wall 28 must belong to the same period as this wall cannot have been built earlier than Room 98 which is shown by the fact that the wall in question abuts against Wall 141. It is obvious that Room 100 was added contemporaneously with Room 98 in order to obtain a straight exterior wall, and it seems likely that the wish to build a more monumental entrance to the S. E. court was the cause of these added rooms, so that Room 100 is to be considered as the principal part and Room 98 was added in order to obtain a straight exterior wall, aligned with the new doorway.

It was shown in the description of the walls that the original doorways leading to Rooms 95 and 96 have been somewhat narrowed by parts added to the flanks of the doorways. It seems reasonable to suppose that these parts were added in the 4th period, as the rooms in question were built in the 3rd period, but, on the other hand, nothing proves that these small parts were not added on a later occasion in the 3rd period: these are not distinct building operations like Rooms 98 and 100.

We now proceed to an examination of the walls in the kitchen-department and the adjoining rooms. In the 1st and 2nd periods, i. e., before the S. E. court was levelled, the form and plan of the kitchen-department were different from those which it obtained later. In order to decide to which period these rooms belong it is necessary to examine the relations of the walls of these rooms to the floors, which can be dated on the evidence of the potsherds found *on* and *below* them. Within Rooms 60—63, 74, 75, 77 there were two floors, one on top of the other and in Room 64 three floors could be observed. Below the lowermost floors in these rooms only potsherds of the 1st period were found (for the pottery evidence in this and the following cases, see Statistical list of potsherds, pp. 281 ff.); on the floors specimens of Type VI together with a quantity of Type V were found, characteristic of the 2nd period, which shows that the floors were used in the 2nd period as well. The upper floor in Rooms 60—63 is therefore to be assigned to the 3rd period. In the filling between the lowermost and the middle floors in Room 64 there were potsherds of Types V and VI which clearly show that the middle floor in this room was laid in the 3rd period and is contemporary with the upper floors in Rooms 60—63 and 74, 75, 77. While these were used in the 4th period as well, a new floor, the third and uppermost, was then laid in Room 64, which furthermore is corroborated by the fact that some potsherds of Type VII were found below that floor.

Walls 101 and 193 are covered by the upper floor in Room 62 + 63, which proves that these walls were only used in the 1st and 2nd periods. The same holds good for the cistern in Room 61 which is covered by the upper floor in that room.

Of the walls of Rooms 74, 75, and 77, Wall 95 is covered by remains of the upper floor in Room 75 + 77 and was consequently not used after the 2nd period. The same holds good for the S. W. part of Wall 98. The other walls of these rooms were in use until the destruction of the palace.

The walls of Rooms 78—80, on the other hand, were not in use after the 2nd period because they are demolished to a level below that of the S. E. court and it can therefore be inferred that their demolition took place at the time of the levelling of the S. E. court, i. e., at the beginning of the 3rd period.

We continue the analysis with an examination of the date of Wall 148. This wall cuts through the lowermost floor of the adjoining rooms and is therefore later than the 1st period. It is bonded to Wall 130 and must therefore be contemporary with it. Wall 130 replaced the original wall 129 which was built in the 1st period as the floor of Room 55, which forms a part of the 1st period complex of Rooms 48—56, abuts against it. Wall 130 must therefore be later than the 1st period, which also is shown by the fact that it cuts through the lowermost floor in Room 64. It can be more exactly dated on the basis of its synchronism with the second staircase leading from Room 55 to Room 64. On the one hand, this staircase, belonging to Wall 130 and founded on the floor of Room 55, must be later than the 1st period. On the other hand, it must be earlier than the 3rd period as it originally led up to the lowermost floor of Room 64 (cf. p. 158). It is therefore to be assigned to the 2nd period and, as a matter of fact, it does not abut direct against the lowermost floor of Room 64 but against the step-shaped ledge of blue-grey cement which is founded on this floor and therefore represents a later addition (cf. p. 149). As mentioned above, Wall 148 is contemporary with Wall 130 and can therefore be assigned to the 2nd period, also.

Wall 147 cuts through the lowermost floor of Rooms 61 and 62. It must therefore be later than the 1st period. As it is not bonded to Wall 148 it is likely to be later than that wall, i. e., later than the 2nd period. The wall replaced an earlier, narrow wall: the continuation of Wall 99; this is almost entirely demolished, only a short piece of its S. W. end being preserved. This earlier wall, which formed a part of the 1st period complex of Rooms 74, 75, 77—80, and was the N. W. wall of Rooms 78 and 80, was evidently demolished at the same time as the other walls of these rooms, i. e., at the beginning of the 3rd period, in connexion with the levelling of the S. E. court. Wall 147 which encloses the S. W. part of this court to the N. W. in the same way as the walls of Rooms 94—97 to the S. E., dates therefore from the 3rd period. In connexion with the erection of the wall the original doorway between Walls 147 and 148 was blocked up with rubble, against which the upper floor of Room 62 + 63 abuts. In the N. E. part of the wall a hole for a drainage channel has been opened after the erection of the wall, as shown above, p. 142. When this was opened, the upper floor of the 3rd period in Room 61 was damaged, which also indicates that the drainage channel is later than the 3rd period. That the drainage channel really dates from the 4th period, is shown by the fact that it runs down the S. E. court and passes through the walls of Room 84 which was built in the 4th period.

The coherent complex of Walls 149—152 cuts through the lowermost floor of the adjoining rooms and is therefore later than the 1st period. The upper floor of the rooms abuts against the walls and they cannot therefore be later than the 3rd period. A closer examination makes clear that they cannot belong to the 2nd period but were built in the 3rd period. Already the fact that the Wall 149 is not bonded to Wall 130 of the 2nd period, but revets

VOUNI

The palace

Façade, Room 10

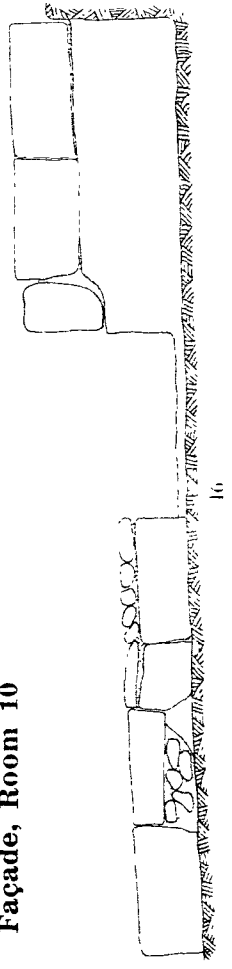

16

1

Façade, Room 10

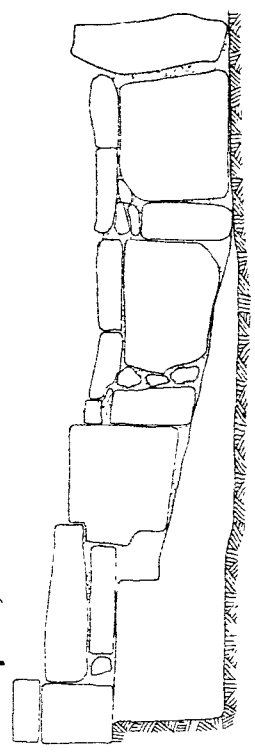

11

2

Façade, Room 11

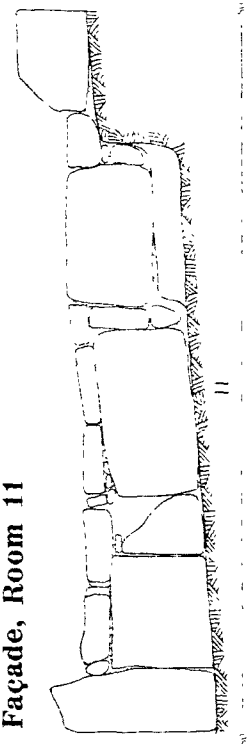

11

3

Façade, Room 11

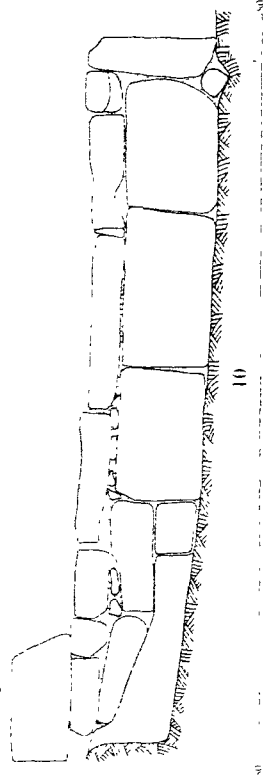

10

4

Façade, Room 12

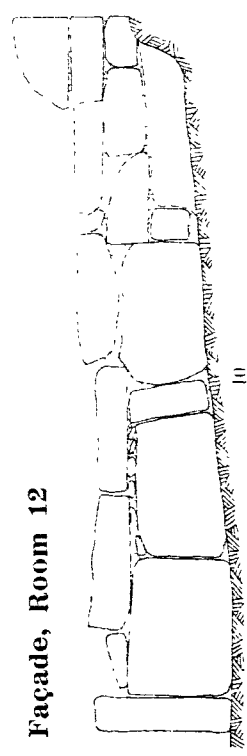

10

5

Façade, Room 13

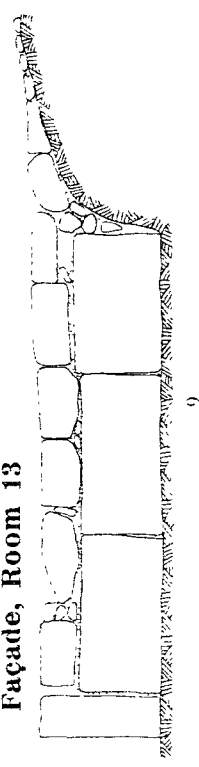

9

6

Façade, Room 14

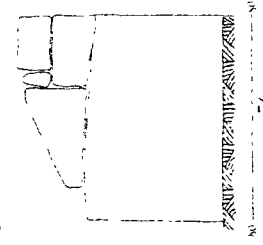

7

7

Façade, Room 14

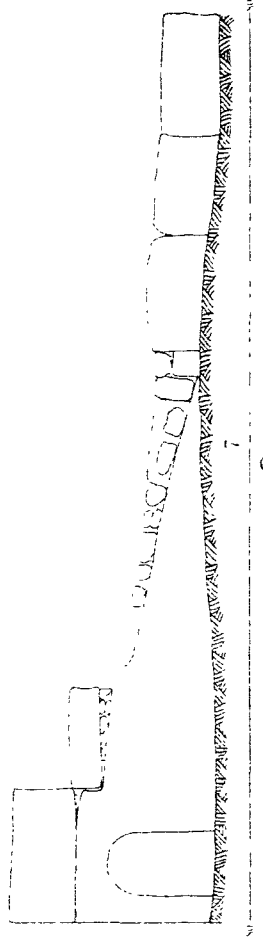

7

8

Façade, Rooms 10—12

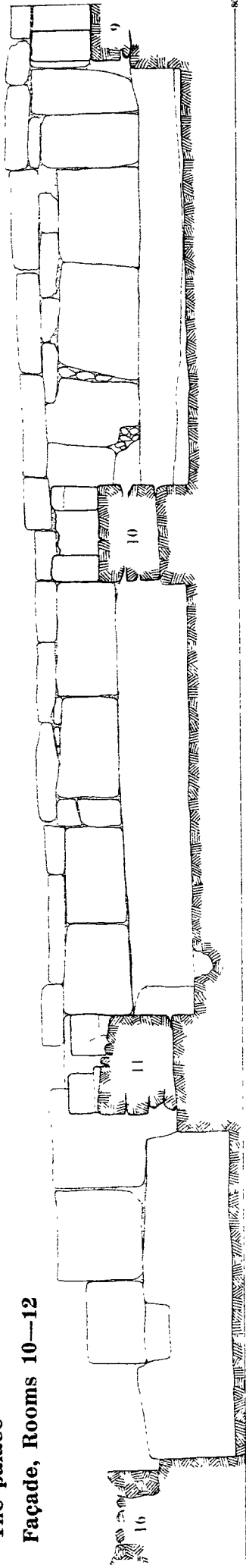

Façade, Rooms 13—14

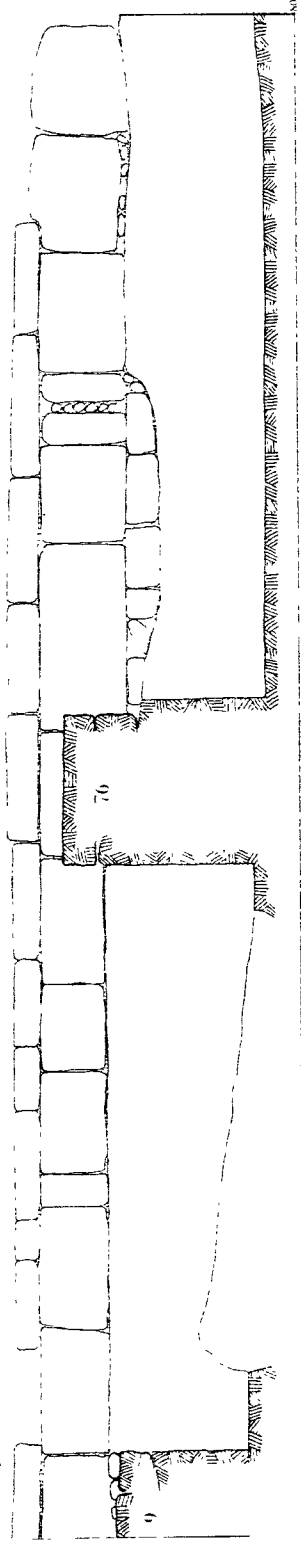

Façades, Rooms 17 and 31

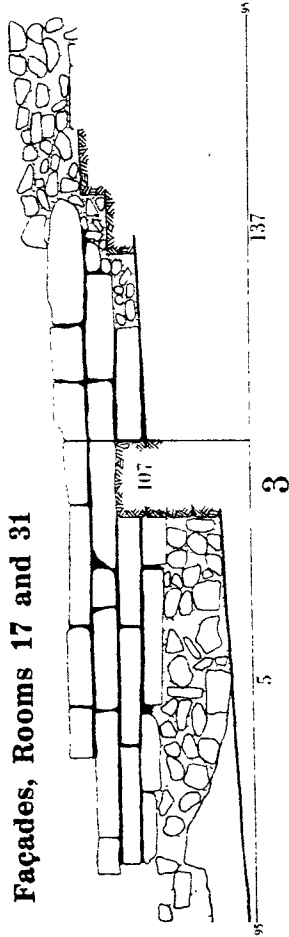

Façade, Room 42

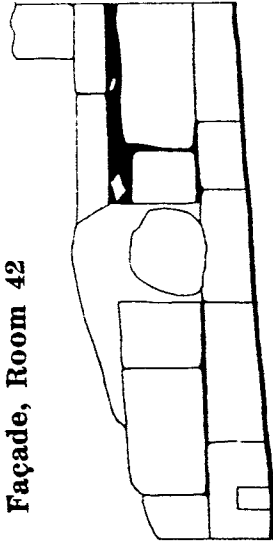

Façade, Room 42

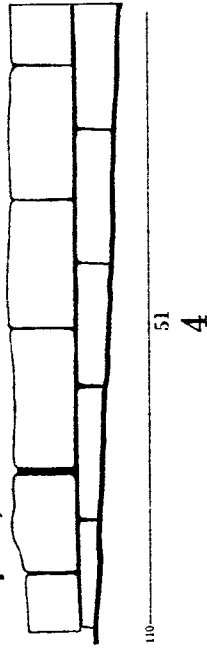

Façade, Room 42

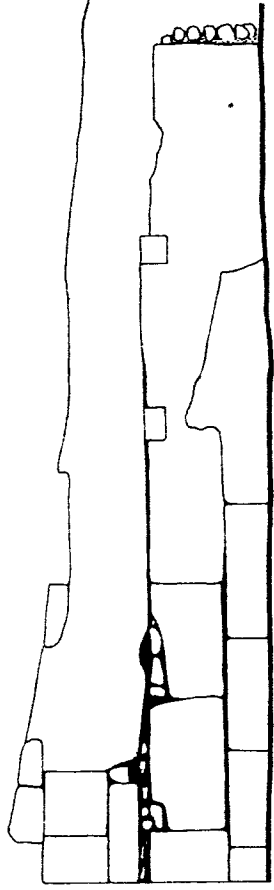

the palace

Façade, Rooms 43—44

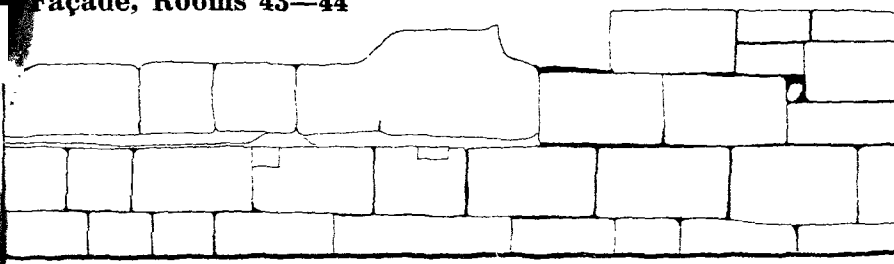

52

1

Façade, Room 43

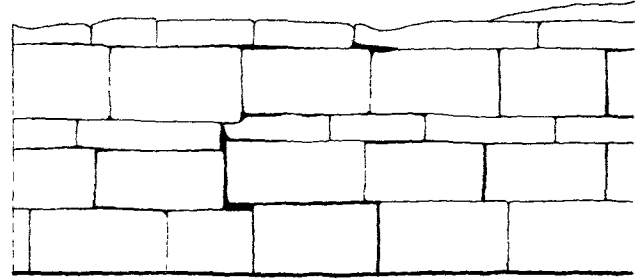

50

2

Façade, Rooms 43—44

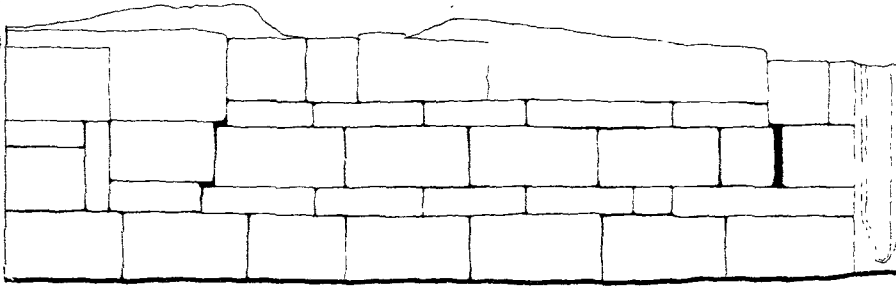

53

3

Façade, Room 44



51

4

Façade, Room 43

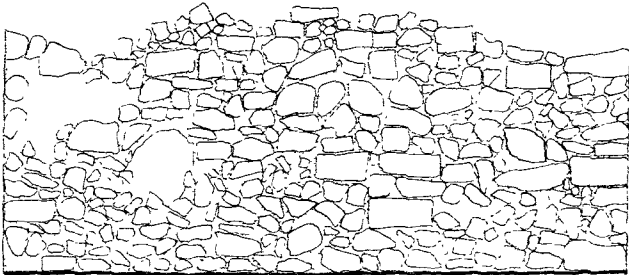

183

5

Façade, Room 44

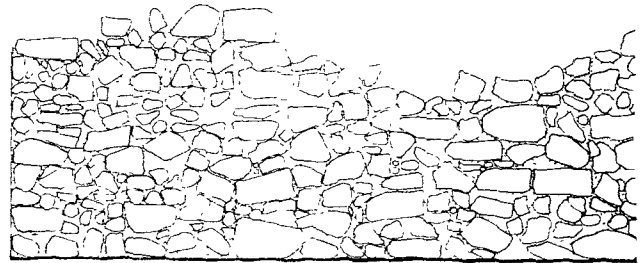

181

6

Façade, Room 45

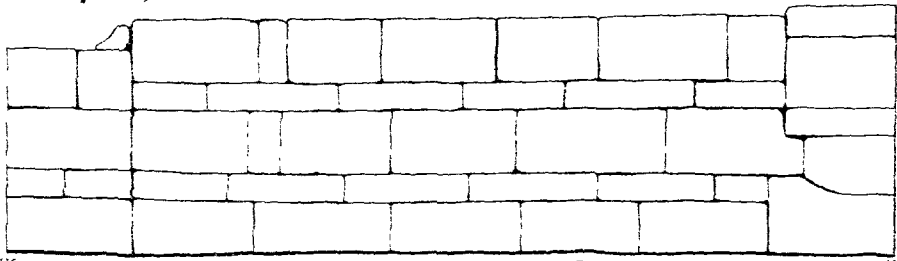

53

7

Façade, Room 45

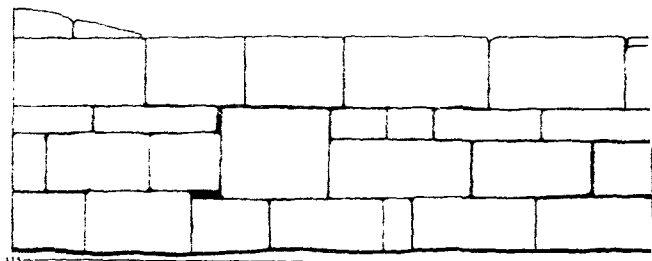

50

8

Façade, Room 45

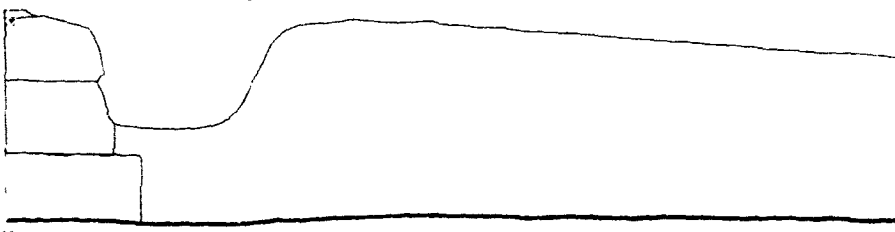

191

9

Façade, Room 45

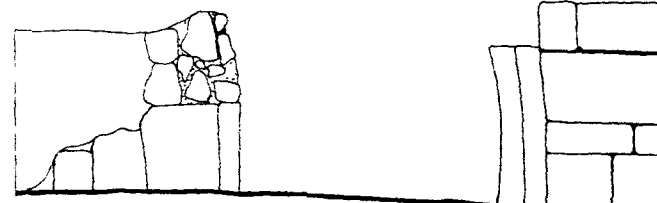

192

10

55

the N. W. end of that wall and the N. W. face of Wall 131, indicates that it is later than that period. Furthermore it is worthy of notice that large pieces of the lower floor of Rooms 59—61 were destroyed at the erection of these walls and wanted repair if it was used. As such a repair was not undertaken, this is an indication that the upper floor of the rooms was laid contemporary with the walls. Finally, the three-flight staircase itself, for the substructure of which Walls 149—152 were built, starts from the upper floor in Room 60 and there are no traces whatever that it originally started from the lower floor. The walls of Rooms 59 and 60 and the three-flight staircase are therefore to be assigned to the 3rd period.

The staircase leading from Room 46 to Room 60 is founded on the floor of Room 46 and Wall 56 was cut through for the passage of the staircase. It must therefore be later than Period 1 and was evidently built in order to obtain communication between the central part of the palace and the three-flight staircase which led to the upper story. The staircase between Room 46 and 60 dates therefore from the 3rd period.

In compensation for the rooms of the kitchen-department demolished at the time of the levelling of the S. E. court (Rooms 78—80) the kitchen-department was enlarged with new rooms to the S. W. Of these, Rooms 71—73, 76, and the kitchen court (Room 66) are assigned to the 3rd period by the evidence of the potsherds found in the filling below the lower floor-level of rammed earth in the court. The filling abuts against the walls of the rooms and contained quantities of potsherds of Type VI, none of Type VII, and a minority of Type V (cf. p. 282).

Walls 83 A—C, 145, 146 of Rooms 67 and 69, on the other hand, are founded in Layer 3 of Section XXVII, while the upper lime-marl floor abuts against them. In this layer, below the upper floor, a majority of sherds of Type VI and stray specimens of Type VII were found (cf. p. 282). The walls in question are therefore to be assigned to the 4th period. The same holds good for the walls of Room 65.

The staircase built in Room 64, along the S. W. face of Wall 148, cuts through the lowermost floor of Room 64, while the middle floor abuts against it. It is therefore later than the 1st period but not later than the 3rd period. Furthermore, being built along Wall 148 it must be either contemporary or later than that wall. It dates therefore either from the 2nd or the 3rd periods. As pointed out above, p. 162, the staircase did not lead to the upper story of Rooms 74, 75, 77, because these rooms can never have had an upper story on account of their narrow and not very solid walls which cannot have supported the pressure of an upper story, but the staircase has apparently led to the upper story of Rooms 71—73 across the roof of Rooms 74, 75, 77 (cf. p. 162), which were built in the 3rd period. This shows that the staircase was built in the 3rd period.

There remains an analysis of the walls in the N. W. part of the palace. Apart from some minor additions and rearrangements all this part of the palace forms a structural unit which is evident from the bonds of the walls and their relations to the common floors. Wall 17 is a continuation of Wall 16 and from this it is clear that the rampway (Rooms 17—19, 25, 26) which is entered through the door in Wall 17 and gives access to the interior rooms of the N. W. part of the palace is contemporary with the store-rooms 10—14. The floor of

this rampway is continuous and has been laid in one piece. This floor, abutting against Wall 17 abuts against all the other walls adjoining the rampway indicating that they cannot have been built in a later period than the ramp and the store-rooms. The floor abuts, too, against the staircase leading from Room 20 to the upper story of Rooms 10—14 which assigns this upper story to the same period as the ground-floor of these rooms. In the same way the floor of the rampway abuts against the staircase leading from Room 19 to Room 29 and the adjoining rooms. This shows that these rooms cannot be later than the remaining part of the N. W. area of the palace, which, consequently, forms a structural unit as mentioned above. If we examine in which period this unit was built, the best dating material is given by the find of a great number of potsherds in the cavity below and above the floor of Room 13 (See Statistical list of potsherds, pp. 281 f.). As shown by Section XXIV (p. 184), Layer 6 forms the original filling of the cavity. This filling contained potsherds of Type V, i. e., the same kind of pottery as was found everywhere below the 1st period floors of the palace. The filling of waste material (Layer 5) accumulated on top of the bottom layer contained a mixture of Types V and VI together with a few specimens of the "Ionian Cup" fabric, Black Glazed Greek, Red Figured, and White Grounded Greek of the early 5th Century B. C., or the kind of pottery found below the floors of Period 3. Layer 3 which consisted of waste material swept away in the sunk part of the floor contained a majority of potsherds of Type VI together with some specimens of Type V and a single transitory specimen between Types VI and VII (White Painted VI—VII). Layer 3 thus dates from Period 3 and the beginning of Period 4. This analysis of the potsherds found in the different layers of the cavity of Room 13 shows clearly that the room was built already in Period 1 and the whole architectural unit of which the room is a part, i. e., the N. W. area of the palace, dates therefore from Period 1.

The vestibule room 16, too, must be assigned to the same period. Its walls (162 and 163) are not bonded to those of the adjoining rooms, but that depends on the different technique of the walls: while the adjoining walls 5 and 17 are ashlar walls of Types 2 and 4, Class A, Walls 162 and 163 are rubble walls of Type 14, only strengthened with ashlar blocks at the entrance. That the room belongs to the 1st period is shown by the fact that the drain cut in the levelled rock floor of the room continues below the cement-floor of Room 17, which dates from the 1st period, as shown above.

As mentioned above, some minor additions and rearrangements have been carried out. The additions are: Walls 105 and 181, the staircase in Room 17 and the staircase from Room 26 to Room 28. All these structures are built on the floor of respective rooms and are therefore later than the 1st period. Rearrangements have taken place at the staircase leading from Rooms 31 and 32 to Room 33. In the description of this staircase the rearrangements are given in detail. Furthermore the cement-floor of Rooms 30—31 has been repaired, an upper cement-floor laid in Room 28, and the outlet of the drain in Wall 12 has been blocked up. Finally, rebuildings have been carried out in Room 14. The original wall dividing Rooms 13 and 14 (Wall 8) has been demolished, as well as the staircase, which once led along this wall to the upper story of Rooms 10—14; a new wall (Wall 76) has been built in the place

of the original staircase, and the exterior doorway in Room 14 has been blocked up, as described above, pp. 117, 134.

This rebuilding in Room 14 seems to date from the 3rd period as the peculiar technique of Wall 76 is identical to that of Wall 74, which was built in the 3rd period. The staircase in Room 17 leading to the upper story of Room 16 and adjoining rooms seems to belong to the same period, as the palace has not had an upper story before the 3rd period (cf. pp. 196 f. and 210), except the upper story of Rooms 10—14 (cf. above) which, however, is explained by the fact that the ground-floor of these rooms was cut in the rock so that its upper story was on a level with the ground-floor of the adjoining part of the palace. Probably the rebuilt staircase from Rooms 31 and 32 to Room 33, the upper floor in Room 28, and the staircase from Room 26 to Room 28 which leads to the upper floor in Room 28 are to be assigned to the same period. The repair of the floor in Rooms 30 and 31 can with greater certainty be assigned to the 3rd period, as this repair evidently was caused by the water-conduit for leading off the water from the roofs of the rooms N. W. of the central court being carried below the floors of these rooms to the cistern in Room 19, when the original water-conduit leading to the tank-cistern in the central court fell out of use. This new arrangement took place when the bottle-shaped cistern in the central court was cut, which was done in the 3rd period (cf. pp. 190 ff.). Whether Walls 105 and 181 were built in the same period or later cannot be determined with certainty. The irregular construction of Wall 181 (cf. Wall 183, p. 192) makes me most inclined to assign it to the 4th period, while the construction of Wall 105 (Type 11) indicates that it probably was built in the 3rd period, as there are no safely dated walls of this type which can be assigned to the 4th period.

The analysis of the palace architecture is now finished. There remains a similar examination of the walls of the cult-houses surrounding the palace. It is more difficult to assign these buildings to respective periods than the walls of the palace as no dateable potsherds were found below the floors and the cult-houses are separate buildings so that their chronological relations to each other cannot be based on structural evidence such as bonds, etc.

We start with the cult-chapel of Room 101. No finds indicate its date. Wall 41 of the room is of the box-wall type, Class C. As all the other walls of this type date from Period 2, I am inclined to assign the room to that period.

We continue with the complex of Rooms 103—110. Room 110 seems to be a later addition, because its orientation differs from the remaining part of the building, its N. W. wall (Wall 188) running parallel with Wall 139 while the remaining part of the building is oriented obliquely to that wall. Room 110 cannot therefore be earlier than Room 98, but must belong to the same period as that, i. e., the 4th period. The other part of the building forms a structural unit and is therefore built at one time. Unfortunately no dating sherds were found in the earth-filling of the cavity below Rooms 107—108, 109, and 110 (cf. above, p. 150) and no finds below the floors of the rooms indicate to which of the earlier periods the building should be assigned. Its orientation, however, is the same as that of the cult-chapel consisting of the single room 117. This can be assigned to the 3rd period (cf. below) and it seems therefore most probably that the original part of the building in question dates from the same period.

The cult-chapel of Rooms 113—114 is also difficult to date as no objects of chronological significance were found there. It is not oriented either to the neighbouring, detached building (Rooms 103—110 and Room 117) or to the opposite walls of Rooms 92—97 of the palace. This latter fact indicates that the cult-chapel is earlier than these rooms of the palace, i. e., not only earlier than the 3rd period (Rooms 94—97) but even earlier than the 2nd period. I am therefore inclined to assign this cult-chapel to Period 1.

The chapel of Room 117 contained a series of votive sculptures of which none is earlier than the 3rd period (cf. p. 278). This fact indicates that the chapel dates from that period.

We proceed now to an examination of the main temenos (Rooms 121—129). This is not only the main temenos but evidently the earliest: only in this temenos sculptures from the 1st period were found *in situ*. An architectural analysis, however, shows that only the nucleus of the temenos can be assigned to the 1st period, and that other parts were added later. The nucleus consists of the altar-court (Room 123), its fore-court (Room 122), and the square room 121 at the S. E. end of the fore-court. This complex of rooms form a structural unit, being enclosed by walls of the same type and bonded to each other, where they are not destroyed, and in the altar-court and around the staircase leading from the fore-court to the altar-court sculptures from the 1st period were found *in situ*, naturally among such of later periods too (cf. p. 277). We are therefore justified in assigning this part of the temenos to the 1st period.

Rooms 124, 125, 126—129 are later additions. Of these, Rooms 126—129 were built in the 3rd period. They must be contemporary with the road which runs along their open front sides and whose pavement of lime-marl is made in one piece with the floor of Room 129. In the filling below the floor of this room and below the pavement of the road potsherds of Type VI, mixed with some transitory specimens between Types V and VI were found. Such a composition of pottery types is characteristic of the beginning of the 3rd period. Walls 186 and 187 of Room 129 seem however to be still later additions (cf. below), and in the 3rd period this room was therefore probably only a part of the road cut in the rock to the S. W. and corresponding to the angular turn to the S. W. of the opposite part of the terrace-wall supporting the filling of the road.

As Rooms 126—129 were built in the 3rd period it is necessary to suppose that the N. E. rubble wall of the temenos continued along Room 122 in the 1st period, but was demolished and the ashlar wall 45 substituted for it during the 3rd period. The S. E. end of Wall 173 has also been repaired at the same time and received end blocks of ashlar.

The staircase leading to the E. corner of Room 122 belongs to the 3rd period, too, as the blocks of its steps are cut to abut against Wall 46. If there was a staircase already in the 1st period, it must have been rebuilt in the 3rd period. The same holds good of the staircase leading to the N. corner of the fore-court.

The blocks of the steps at the S. E. flank of this staircase have been removed and are partly cut off by the short, oblique piece of Wall 169 B and the cemented water-conduit along the wall. This proves that the water-conduit now preserved and the walls of Room 125 are later than the 3rd period and this room should therefore be assigned to

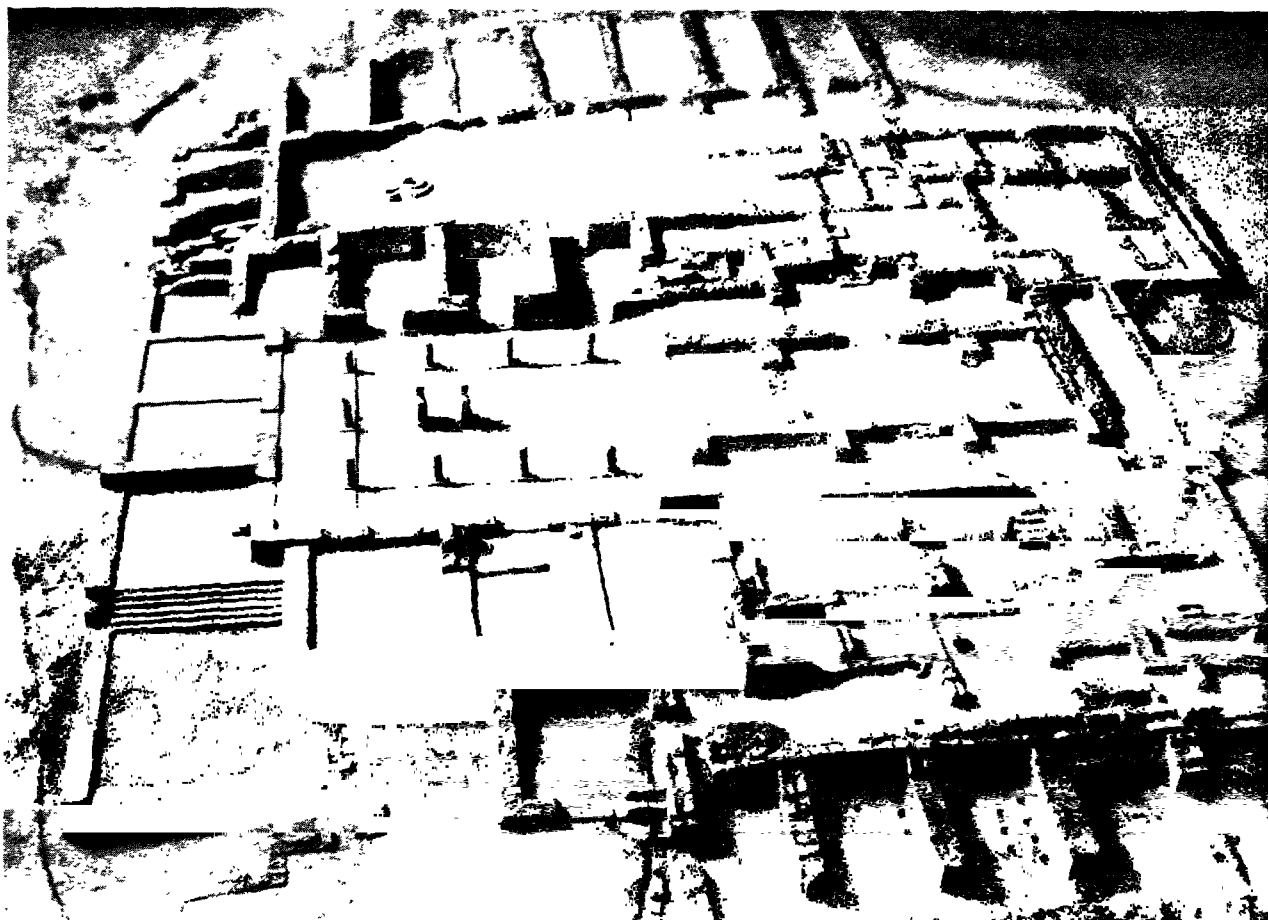

Fig. 121. Vouni. A model of the palace, seen from the N. W. The columns of the peristyle, the mouth of the cistern in the central court, and the staircase in Room 7 A are reconstructed, the latter in a somewhat wrong way.

the 4th period. Probably the water-conduit now preserved, replaced an earlier conduit of the 3rd period.

Room 124, finally, is a later addition, too, because Walls 184 and 185 are not a continuation of the adjoining wall 170, being built in another technique and not bonded to it; besides, the walls of Room 124 enclose an area which was not intended to be enclosed from the beginning as drains are cut across the place. In consideration of the fact that Wall 186 is constructed of rubble in an irregular technique (Type 15) characteristic of the 4th period, it seems indicated that the room belongs to that period.

As regards the dating of the chapel consisting of Rooms 132—135, it is to be observed that below the floor-level of Room 130 B waste objects of *ex votis* of an earlier period were found in the filling on the rock, and in the chapel were fragments of sculptures of which the earliest belong to the 3rd period. On this evidence the cult-chapel is assigned to the 3rd period.

Remains of another cult-house were found W. of the palace. The architecture of this cult-house is not much known as only a small part could be excavated. It is therefore not included on the architectural plan of the palace. The specimens of sculpture found within the ex-

cavated area range from Style II to Style IV (Nos. 571—584), and it seems therefore probable that the cult-house was built in Period I and was in use until the destruction of the palace.

ARCHITECTURAL SYNTHESIS (FIGS. 121—142; PLANS IX, XXIV, XXV)

Summing up and combining the facts given above in the description of the architectural elements and in the analysis of the architecture we shall now proceed to the architectural synthesis.

Period I.

Material and construction.

The majority of the walls are built of mud-bricks on stone foundations. Only Walls 191—193 are entirely built of mud-bricks on a levelling substructure of fragments of stone.

The foundation walls are built of ashlar blocks and rubble. Of the ashlar walls, the following types occur: Type 1 (Walls 1—4); Type 2 (Walls 5—6); Type 3, Class A (Walls 7—11); Type 3, Class B (Wall 12); Type 4, Class A (Walls 15—20); Type 4, Class B (Walls 36—40); Type 5 (Walls 50—56); and Type 6, Class A (Wall 57). The rubble walls are represented by the following types: Type 10 (Walls 92—101); Type 11 (Walls 102—104, 106—108); Type 12 (Walls 119 A, 121—125); Type 13 (Walls 126—129, 131—138); and Type 14 (Walls 156—163, 165, 166, 169 A—173).

Usually the stone foundations project only a few decimetres above the floor-level, even when they are entirely preserved. In Rooms 42—46, however, the stone walls were so high that only the top part of the walls below the roofs was built of mud-bricks.

As far as evidence goes, the gates and doors were of a uniform construction. The thresholds, jambs, and lintels were of wood, as naturally the doors themselves. The wooden thresholds usually rested on a substructure of stone slabs or rubble, or in one case (Room 16) on a rock-cut elevation. The wood has decayed, but there are impressions of both the thresholds and the jambs in the substructure of rubble and lime-mortar and the flanks of the walls in Rooms 44—45. The door-jambs of the wider doors seem to have rested on stone bases, and in the narrower doors of normal width on the thresholds. As there are no traces of hinges, it seems likely that the doors turned on pivots. In the stone thresholds of the gate in Wall 28 belonging to the 4th period, pivot-holes are preserved.

The floors were of different construction. Floors of Type 1 occur in the store-rooms 10—12, the vestibules 16 and 27, the open room 28, in the altar-court of the temenos and the small room 121 at the back of the fore-court of the temenos. Floors of Type 2 are represented in the store-room 13 and the vestibule 14; the kitchen-court had a floor of Type 3, the fore-court of the temenos a floor of Type 4, and the kitchen a floor of Type 7. The floors of these types were thus used in the peripheric parts of the palace: in the store-rooms, vestibules, and open courts. In the interior rooms the floors are exclusively of Type 5.

The floors are either laid direct on the levelled rock, or its irregularities are levelled with a filling of earth. In places where the rock slopes steeply, e. g., in Rooms 33—36, 37—40, this filling is very deep.

VOUNI

The palace

Façade, Room 46

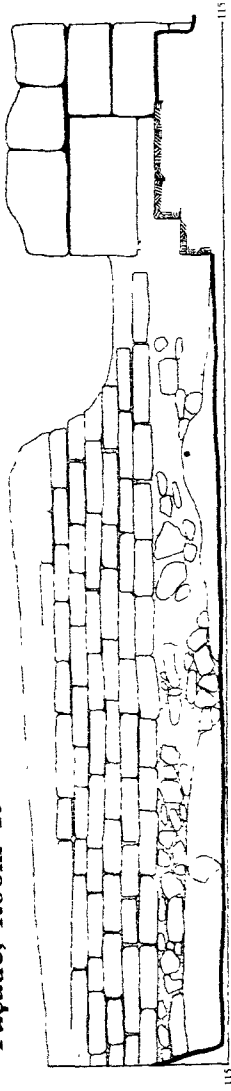

Façade, Room 46

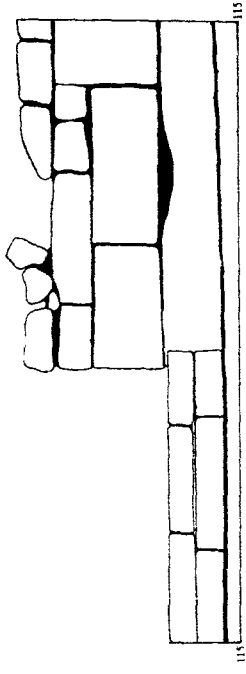

Façade, Room 46

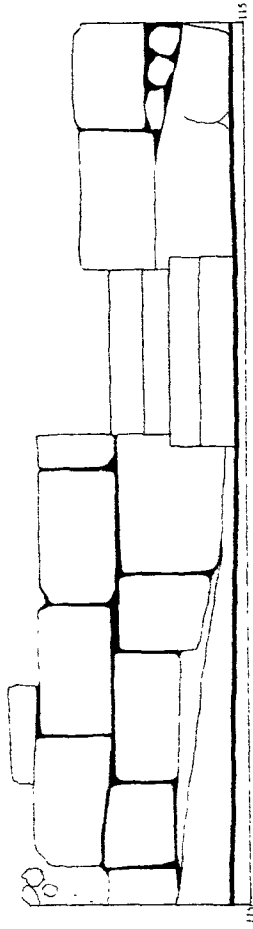

Façade, Room 46



Façade, Room 55

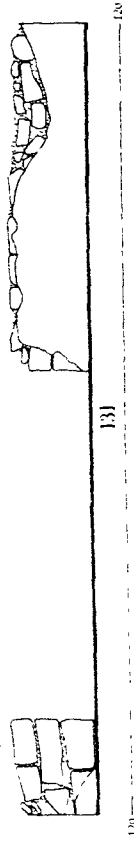

Façade, Room 55

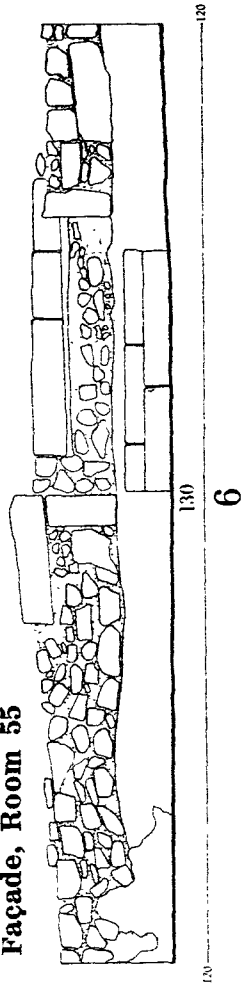

Façade, Room 55

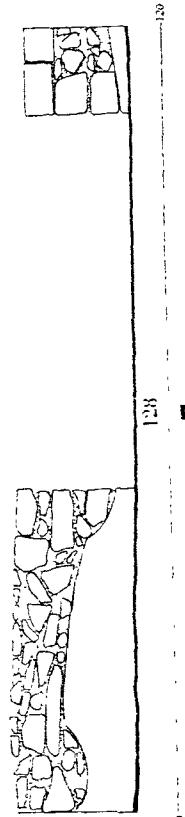

Façade, Room 55

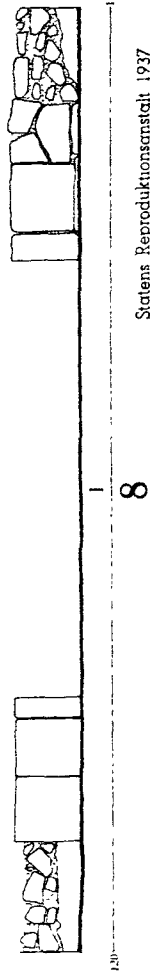



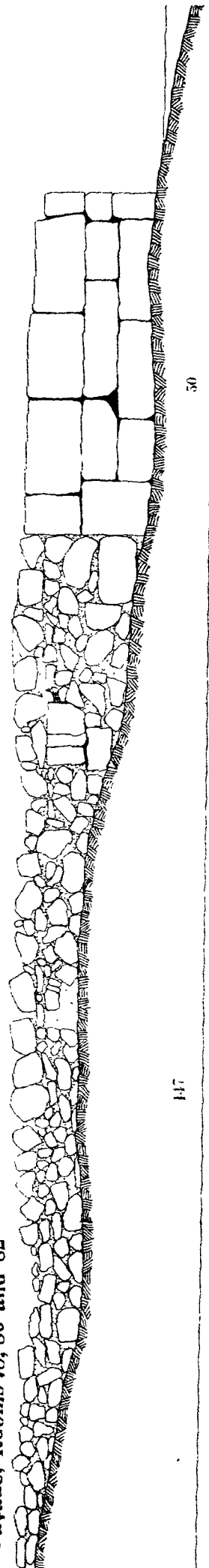

Façade, Rooms 82 and 84

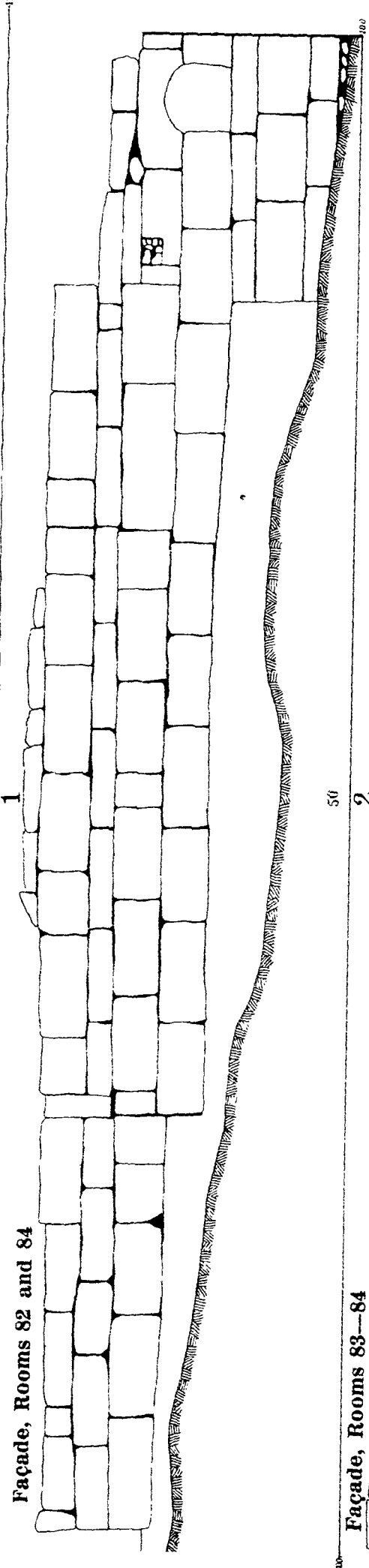

Façade, Rooms 83--84

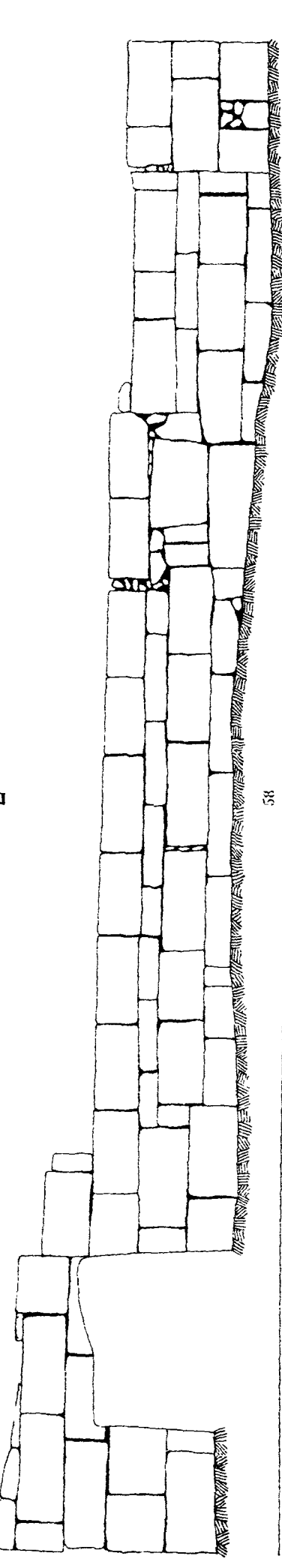

Façade, Room 83

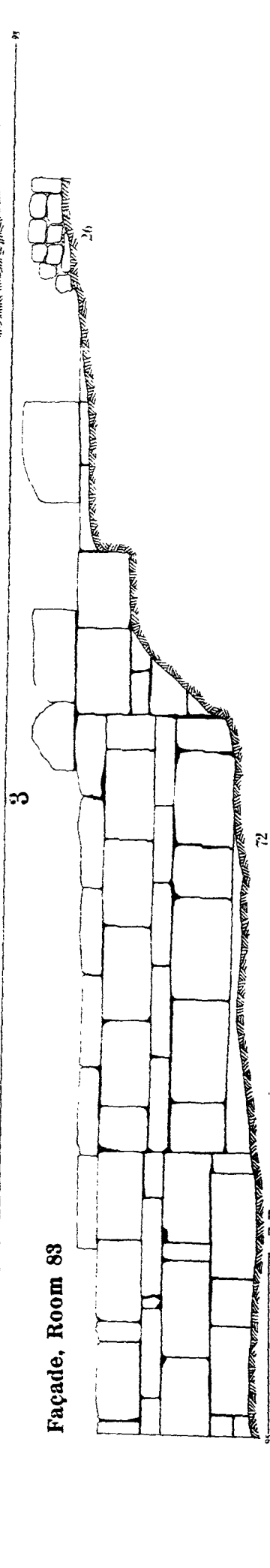

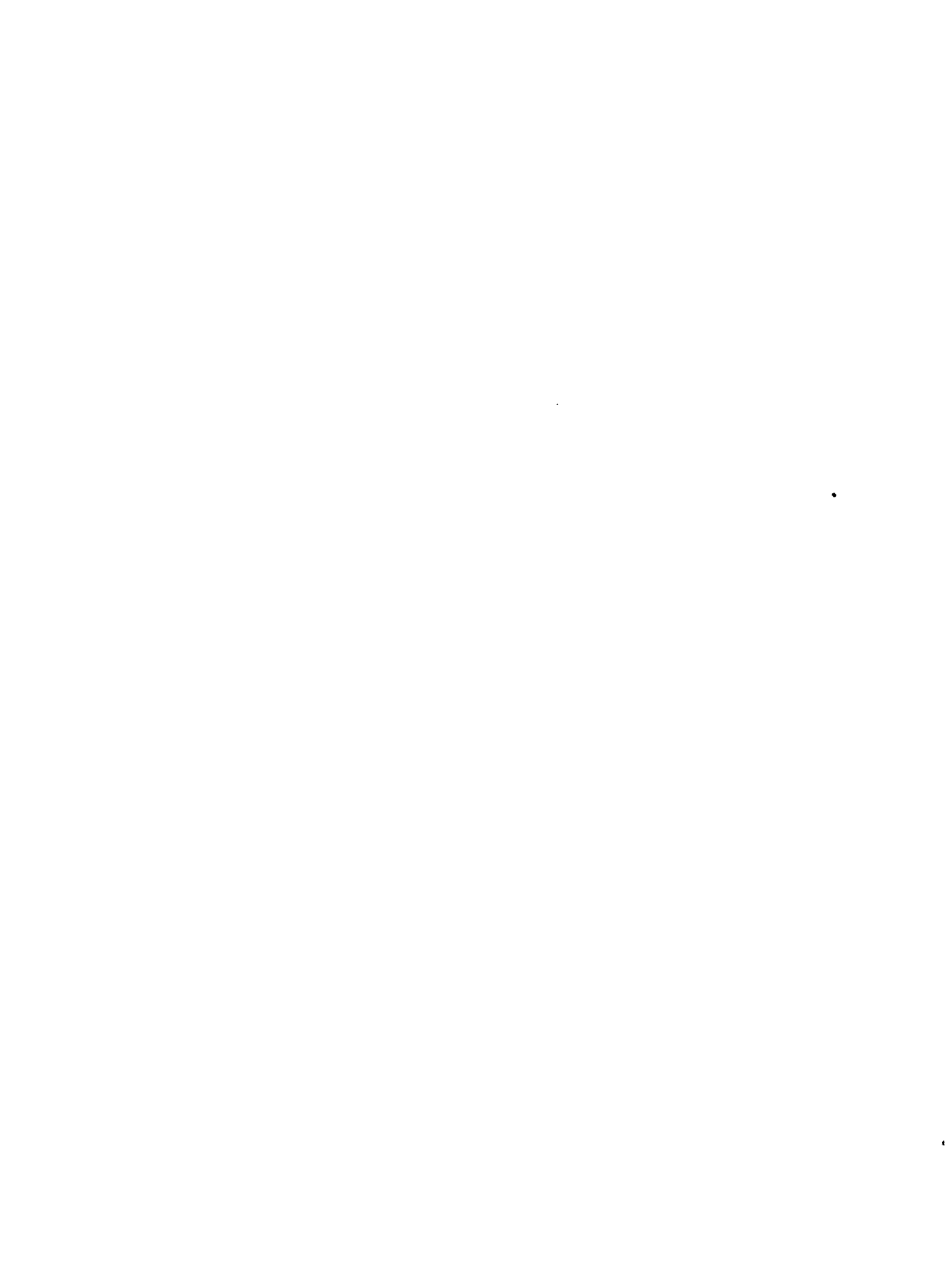

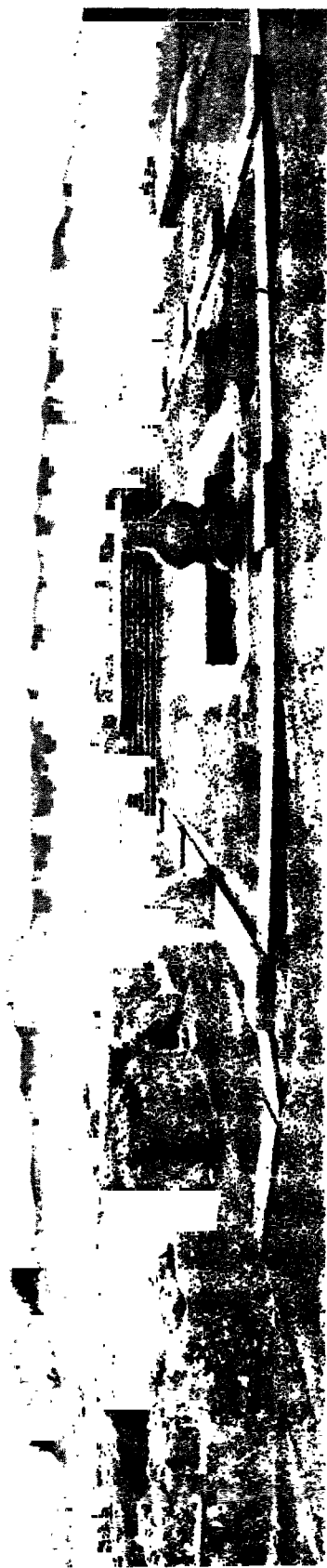

Fig. 122. Vouini. The palace. View of the central court with the adjoining rooms, from the N. E.



Fig. 123. Vouini. The palace. View of the central court with the adjoining rooms, from the East.

The stairs are of the short, straight type, facilitating communication between rooms on different levels, except the long, straight staircase leading to the upper room 13 from the vestibule 14.

The roofs were constructed of a matting of reeds ceiled with earth and lime-mortar and resting on wooden beams, which is shown by the finds of impressions of reeds in pieces of the collapsed roofing. The roofs were not exactly horizontal but slightly sloping.

Columns were used to support the roofs of the halls and the peristyle portico around the N. W., N. E., and S. E. sides of the central court. The stylobate consists of well dressed rectangular slabs resting on a substructure of chips of stone. The columns were placed on a low plinth consisting of rectangular stone slabs. Both types of columns were represented: Type 1 with cylindrical shaft, and Type 2 with a shaft which in section has the shape of an ellipse with ends cut off.

The rain-water collected on the roofs was carried in water-conduits to a number of cemented cisterns cut in the rock. Three types are represented: the tank-cistern in the central court, the well-shaped cistern in Room 35, and the bell-shaped cisterns in the part of the kitchen court, later occupied by Room 61, in Room 19, and in Room 26. The water collected in the tank-shaped cistern ran in a subterranean, cemented passage cut in the rock to the well-shaped cistern from where it was drawn. The tank-shaped cistern was probably covered with a wooden floor.

The water-conduits through which the water was carried to these cisterns are of the three types existing: water-pipes of terracotta were used in roofed-in rooms; cemented conduits, U-shaped in sections, and ending in rounded, cemented basins were used in the open parts of the palace, and cemented conduits covered by stone slabs below the floors.

Drains of all the types are represented: either cut in the rock, with or without a cement coating, or cut out of joined stone blocks; the former types are always used in the open places within and outside the palace, the latter type below the floors and when the drainage channels were to pass through walls. Drainage channels occur also in some roofed-in rooms to lead off the water slopped on their floors, which slope toward the outlet: Rooms 22, 23, 40, and 42. They are therefore interpreted as bath-rooms. In Rooms 40 and 42 there are marks of water basins on the floor, and in the S. W. wall of Room 42 a horizontal groove runs along the whole length of the wall, about 0.90 m. above the floor. Immediately below this groove there are three square holes through the whole width of the wall at fixed distances from each other, as mentioned in the description of Wall 52. It was there suggested that wooden transverse beams were fixed in the holes, and that a wooden board inserted in the groove rested on these beams. It seems likely that this wooden bench was used as a place where the bathers lay for oiling and rubbing. The water in which the bathers washed after this oiling and rubbing must therefore have been hot, i. e., Room 42 is a *caldarium*. There are no traces that the water was heated in the *caldarium*, or in some place close by, and it was therefore probably brought there from the kitchen. As there are no similar traces of such wooden benches in the other bath-rooms, these were probably only used for washing in cold water, i. e., these bath-rooms were *frigidaria*.



Fig. 124. Vouni. The palace. View of the reception rooms (48—56) from the S. W., with the central court in the background.

Form and plan.

The Vouni palace of the 1st period faced the S. W. where the main entrance was situated. This entrance opens on to the state apartments, consisting of a tripartite complex of rooms with a dominating central part (Rooms 51—53) and two lateral parts (Rooms 48—50 and 54—56). The central part consists of an outer entrance hall (Room 53), which was entirely open to the S. W., the principal room of the state apartments (Room 52) measuring 9.40 m. in length and 7.25 m. in width, and an inner hall (Room 51) with open front towards the N. E. In the middle of this open front, there was a column supporting the roof. Probably there was a similar column in the middle of the open front of the outer hall, though this could not be ascertained on account of the later cross-wall (Wall 73). The doorways between the halls and the principal room are 4.00 m. in width. The lateral parts of the state apartments consist of three rooms, which are of different length and width, and the opposite rooms on each side of the central part are not of equal size and shape. The N. W. rooms are narrower than those of the S. E. part and the middle room of this part (Room 55) is larger than any of the others. The outer rooms (50 and 56) are entered from the outside through separate doorways, the middle rooms (49 and 55) communicate with the principal room of the central part by wide doorways, measuring 3.35 m. in width, and the inner rooms

(48 and 54) open on to the central court. Besides, there are doorways leading to the adjoining S. E. and N. W. wings of the palace from the middle of the S. E. side rooms (55) and the outer of the N. W. side rooms (50). The state apartments of the palace thus consist of a tripartite complex of rooms with a dominating principal room in the middle, which are in direct communication with each other, and the other parts of the palace, but form together a structural unit. The rooms — apart from the halls — are narrow-fronted. In regard to the fact that the walls of the central part are considerably wider than those of the side rooms it is probable that the central rooms were higher than the side rooms and covered by a lantern roof (cf. p. 154).

From the state apartments one descends to the central court by a magnificent staircase of seven steps extending across the whole width of the court.

The central court is 17.80 m. long and 16.75 m. wide, consequently almost square. It is surrounded on three sides, in N. W., N. E., and S. E., by a peristyle portico whose roof was supported by columns, while the centre of the court was open. The peristyle has three columns on the short side and four on the long sides, the columns in the angles between the long sides and the short side in both cases included. The columns at the S. W. ends of the long sides and in the angles between the short side and the long sides were of the elliptical type (Type 2), the latter being of a somewhat smaller size than the former and placed in the direction of the short side. The other columns were cylindrical (Type 1).

On the open place in the centre of the court, is the large, tank-shaped cistern, which received water from the roofs of the rooms around the court.

The rain-water falling on the open part of the court was carried off by a drainage channel with its opening in the floor close to the middle of the short side of the peristyle, and running below the floor of Room 38 to the road along the N. E. exterior wall of the palace.

On the N. W. of the central court there are two rooms (33 and 34—36). Of these, Room 33 is narrow-fronted and opens on to the central court by a doorway of normal width, being 1.85 m. wide; besides, a narrow doorway, 1.45 m. wide, in the S. E. wall of the room admits communication with the western part of the palace. On the other hand, there is no direct communication between Rooms 33 and 34—36. This latter room is wide-fronted; it is 12.0 m. long and 7.30 m. deep and opens on to the central court with an aperture measuring 8.25 m. in width. Approximately in the middle of the open front side is the well-shaped cistern situated. As the aperture seems to be rather too wide to be spanned by a wooden beam without the support of a column, it is possible that there was a column on the site of the later wall 74, but this cannot of course, be proved.

Along the N. E. short side of the court there are three rooms (37—39) with narrow front and approximately of the same size, about 5.00 m. wide and 6.20 m. deep. The rooms do not communicate direct with each other, but open on to the central court with doorways in the middle of their front walls. The floors of Room 38 and 39 are approximately on a level with that of the court, but the floor of Room 37 was on a somewhat lower level and a flight of four steps was therefore built in the room in front of the doorway, in order to communicate between the room and the central court.

Along the S. E. long side of the court three rooms are situated (Rooms 43+44—46). They are all narrow-fronted, Room 43+44 is 4.80 m. wide and 6.80 m. deep, Room 45 is 4.95 m. wide and 6.80 m. deep, and Room 46 4.80 m. wide and 6.80 m. deep. The rooms are consequently, approximately of equal size. Like all the other rooms around the central court they do not communicate direct with each other, but open on to the court with doorways in the middle of their front walls. Besides, in Room 46 there is a doorway at the N. E. end of its exterior wall leading to the open, still unoccupied space there.

In the angle between the rooms along the short side and the S. E. long side of the court two rooms are placed (Rooms 40 and 42) which have no corresponding rooms in the opposite angle between the short side and the N. W. long side of the court, which was unoccupied in this period. Room 42 measures 4.10 m. \times 6.90 m. and communicates with the court by a door at the S. E. end of its front wall. Room 40 measures 3.95 m. \times 4.60 m. and only communicates with Room 42 by a door at the right end of its S. E. wall. These rooms are bath-rooms. On their floors there are marks of wash basins, in Rooms 42 near the S. corner and in Room 40 near the S. W. wall. The floors of the rooms slope towards outlets for the water, in the E. corner of Room 42, and in the S. corner of Room 40. The water was carried in water-conduits to Room 85.

Room 42 is a *caldarium* where the bathers were oiled, rubbed, lying on a wooden bench along the S. W. wall of the room, and washed in hot water. Then they proceeded to the *frigidarium* (Room 40), where they washed themselves in cold water.

The part of the palace now described forms its main body: a dominating complex of rooms in the centre of the palace and erected around the central court. The state apartments are placed at the entrance and the private rooms open on to the court but do not communicate directly with each other: they are grouped centripetally around the court. The axial line of the entrance and the state apartments coincides with that of the court, and that of the middle of the three rooms at the N. E. short side of the court. The building, consequently, shows perfect axially. On the other hand, the complex of rooms around the court lacks frontal effect: the main room is not placed at the back of the court but asymmetrically on its N. W. long side (Room 34—36). In the same way, though the plan shows a geometrically simple and clear conception, it is devoid of perfect symmetry. Already the asymmetrical position of the main room of the private apartments shows this; furthermore, the corresponding side rooms of the state apartments are not of equal size and shape, and, as pointed out above, there is nothing to correspond to the bath-rooms on the opposite side of the court; finally, as a door was made into the bath-room 42 from the court, the walls of the rooms at the S. E. long side of the court had to be located somewhat to the S. W. in relation to the corresponding walls of the rooms on the opposite side.

S. E. and N. W. of this central complex two wings adjoin: in the S. E. the kitchen-department and in the N. W. some living-rooms, bath-rooms, and the store-rooms.

The kitchen-department consists of a number of small rooms (74, 75, 77—80) placed along the S. E. side of a rather large, open court, occupying the area of the later rooms 59—64. The court is 18.75 m. long and 4.75—6.75 m. wide, irregularly rectangular in shape,

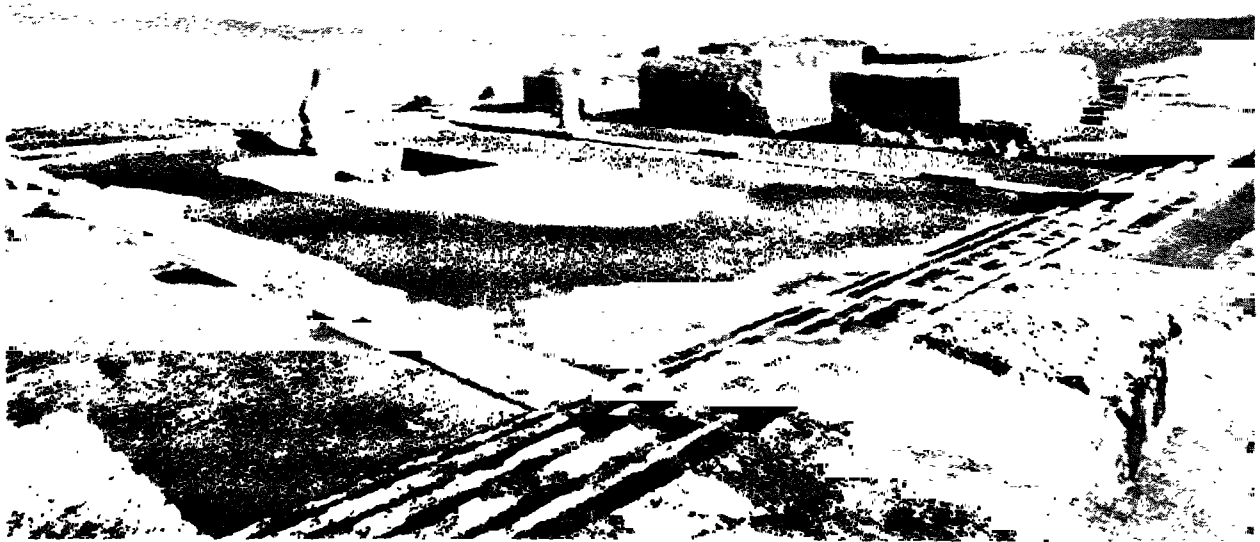

Fig. 125. Vouni. The palace. View of the central court from the West.

the middle part of its N. W. wall projecting into the court owing to the fact that the middle room of the S. E. side rooms of the state apartments (Room 55) occupied this projecting part. Near the S. W. end of this projecting wall there was a door through which the kitchen court communicated with the state apartments by means of a flight of steps leading to Room 55. A part of the court was screened off by Walls 101 and 193 and in the N. E. part of the court there was a cistern cut in the rock. This cistern received the water from the roofs of the rooms of the kitchen-department. Possibly the water from the S. E. part of the state apartments, too, was collected in this cistern as there is a water-conduit cut in the rock and running in the direction of Room 55, but it may also have been carried in water-conduits along the roofs to the water-pipe in Room 43+44 and thus received by the tank-shaped cistern in the central court.

The termination of the kitchen-court to the S. W. is uncertain. Possibly it was bounded there by a wall running in the direction of the later Wall 143, but of such a wall there were no traces. In the E. corner of the court there was a doorway through which it was entered from the outside.

The kitchen was located in Room 75, where the open hearth bordered by a group of stones was situated along the S. W. wall of the room.

VOUNI
The palace

Façade, Room 86

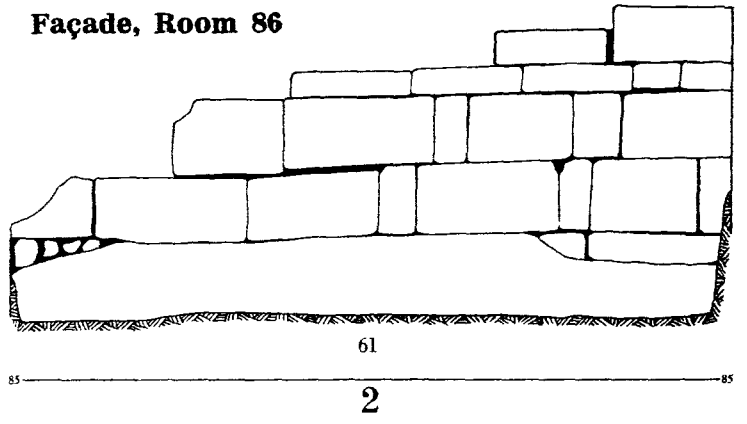

Façade, Room 86

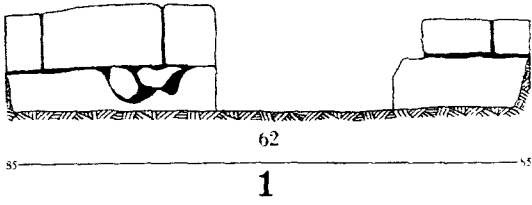

Façade, Room 86

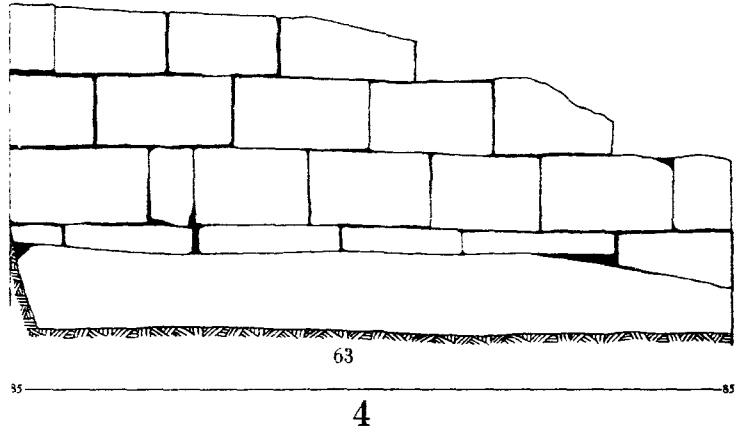

Façade, Room 86

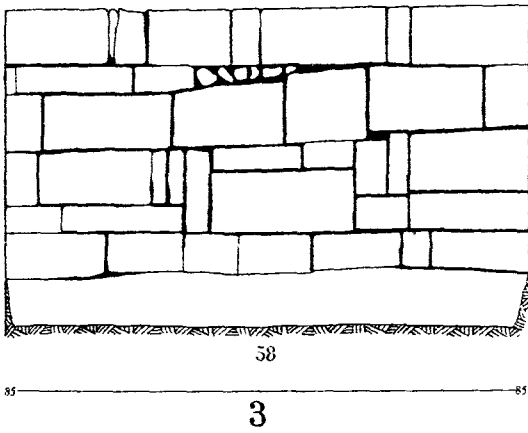

Façade, Room 87

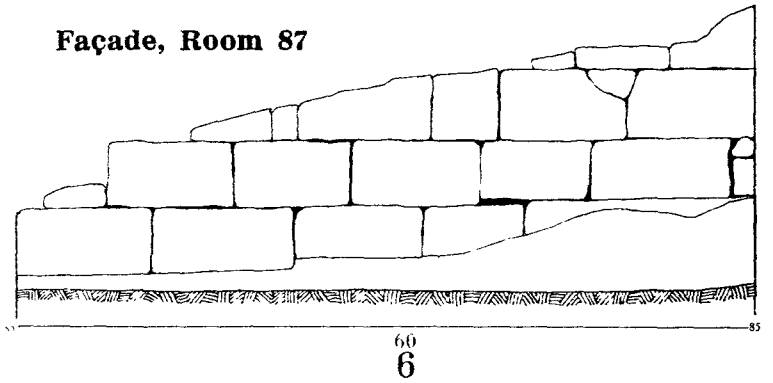

Façade, Room 87

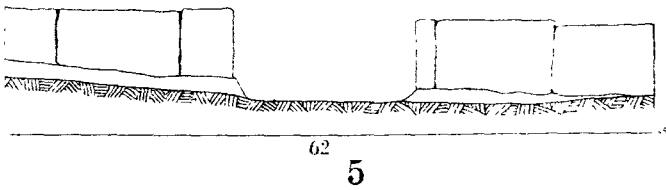

Façade, Room 87

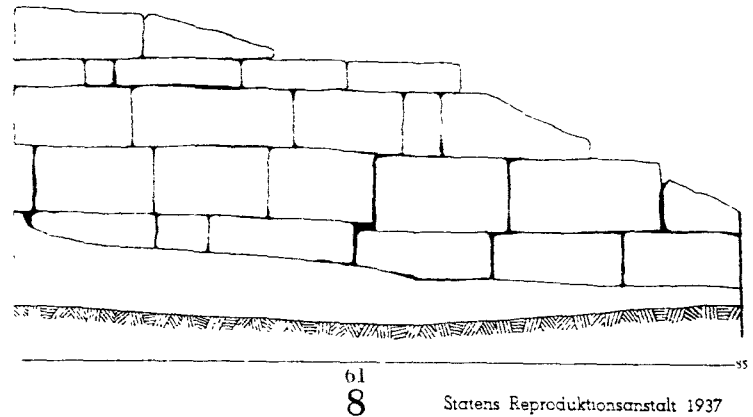

Façade, Room 87

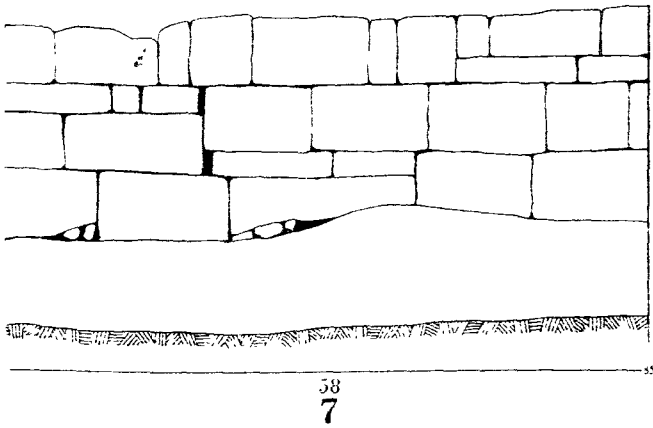

Façade, Room 88

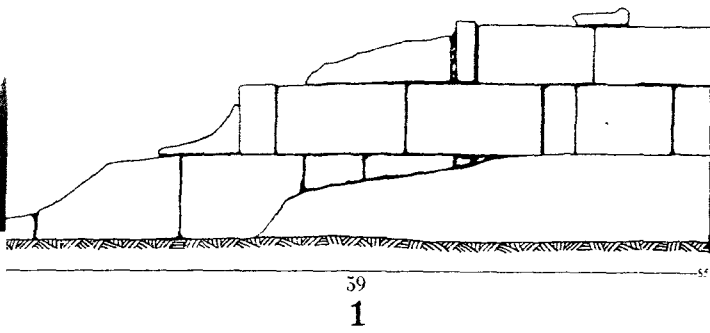

Façade, Room 88

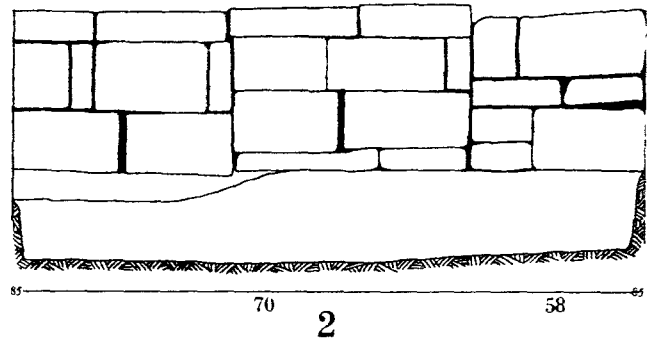

Façade, Room 88

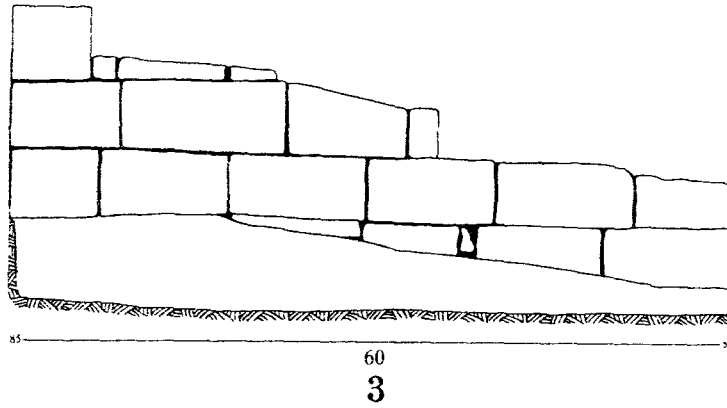

Façade, Room 92

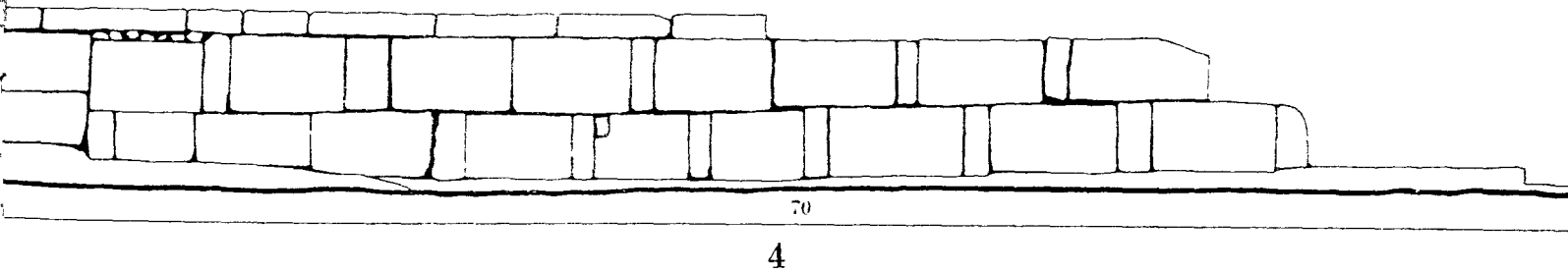

Façade, Room 92

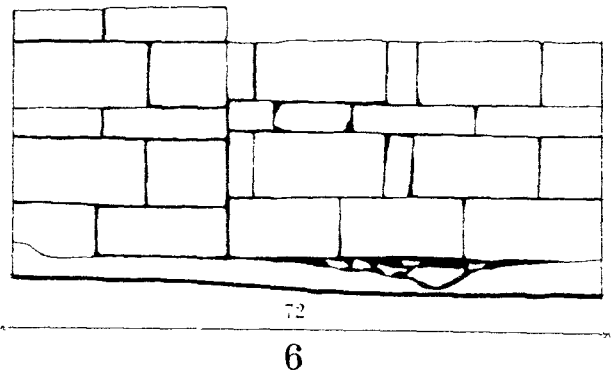

Façade, Room 92

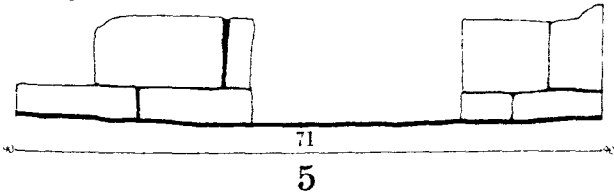

Façade, Room 92

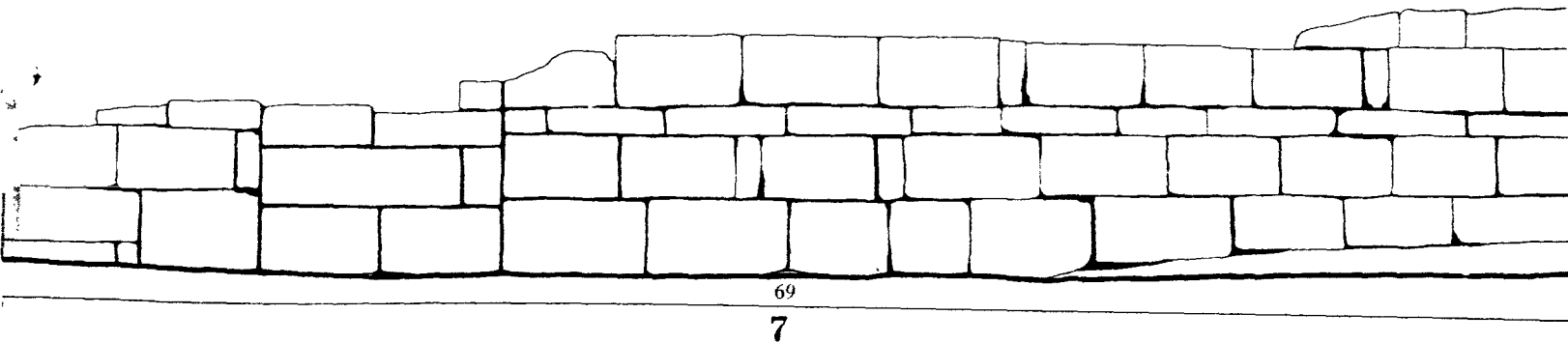



Fig. 126. Vouni. The palace. View towards the West from Room 44. Remains of a water-conduit in the W. corner of the room.

The S. W. wing consists of an open court (Rooms 19, 20, 25), which to the S. W. narrows into an open passage (Room 26) and to the N. E. into an open ramp, ascending to the court. That not only the court but the ramp and the passage, too, have been unroofed is shown by the fact that open water-conduits and cisterns were found there. Water-conduits of this construction are only used in open rooms; in a room covered by a roof, water-pipes are used (cf. Room 44). For the same reason, it can be concluded that the small room 28 was open, as there was an open water-conduit descending from the roof of Room 50 along its S. E. wall and running across its rock-floor and then below the floor of Room 29 to the cistern in the open court (Room 19). The drainage channel carrying off the rain-water falling on the floor of the room to a cavity below the floor of Room 26 proves, too, that Room 28 was unroofed.

Around these open places, which correspond to the open kitchen court in the S. E. wing of the palace, the rooms are grouped: some living-rooms (29—32) in S. E., a suite of store-rooms (10—13) in N. W. and a couple of bath-rooms (21—23) in S. W.

The store-rooms are entered from the outside through a door in Wall 16 and open on to a common corridor running along the N. W. exterior wall of the palace. In the floor

of two store-rooms (11 and 12) there are conical holes cut in the rock-floor for supporting large pithoi with pointed bases. Fragments of such pithoi were found in the store-rooms.

The bath-rooms have cemented walls and their floors slope towards outlets in the S. W. walls. These bath-rooms have therefore only been used for washing with cold water from water-basins apparently placed on the rubble platforms at the S. E. walls of the rooms.

In the open passage, close to the wall of the bath-room 23 there is a bell-shaped cistern which has received water from the roofs of the bath-rooms and probably those of Rooms 13—14, too, through a water-conduit descending along Wall 160. In the open court there is another, bell-shaped cistern receiving water from the roofs of Rooms 48—50 by the water-conduit in Room 28; from the roofs of Rooms 29—32 by a water-conduit descending down Wall 107; and from the roofs of Rooms 10—12 by a water-conduit descending down Wall 18.

Besides, there was a water-conduit descending from the roof of Room 16 to a water-basin in the open place between the inner face of Wall 17 and the N. E. end of Wall 18. From the basin the water was carried by a drainage channel below the floor of Room 17 across the rock-cut floor of Room 16 to the open space between Rooms 10 and 16. That the water collected on a roof of the palace was allowed to be wasted is a unique phenomenon and is explained by the fact that the roof of Room 16 was on a lower level than both the adjoining rooms 33—36, the difference in height between their floors being more than 2 metres, and Rooms 10—14 which already in the 1st period had an upper story (cf. below). It would therefore have been necessary to cut a special cistern for the water from the roof of Room 16 which was not considered worth while, and the water was therefore allowed to be wasted (cf. the changed conditions in the 3rd period, pp. 221 f.).

This S. W. wing communicates with the interior of the palace by two entrances, the one leading by a staircase from the court to Room 29 and from there by another staircase to Room 50; the other leading from the ramp by a staircase from Room 31 and to Room 32, and by another staircase from that room to Room 33.

From the outside, this part of the palace is entered through three vestibules: one in Room 27 leading to the open passage S. W. of the court; another in Room 16 leading to the ramp; and a third in Room 14, leading by a staircase to the upper story of Room 13 and from thence by another flight of steps to the open court.

Apart from this upper story above the store-rooms, the palace of the 1st period was without an upper story, which can be concluded from the fact that there are no staircases leading to such a superstructure. The upper story above the store-rooms, moreover, was on a level with the rooms of the ground-floor in the adjoining part of the palace because the rooms of the ground-floor were to a great extent cut in the steeply sloping rock.

Outside the palace, at a distance of about 12.0 m. from its N. E. exterior wall, a temenos was erected on the rocky hill-slope. This temenos consists of a rectangular altar-court, measuring 10.0 m. in length and 5.75 m. in width, with a rectangular recess 4.50 m. \times 4.60 m., in its N. W. part, a rectangular fore-court, 11.70 m. \times 6.0 m., and a small room (121) at the back of the fore-court, and communicating with it by a rock-cut flight of steps leading to a doorway in its W. corner.



Fig. 127. Voumi. The palace from the West with the store-rooms 10—14 in the foreground.



Fig. 128. Voumi. The palace from the S. W.

It is not quite clear how the fore-court was entered from the exterior. In the 3rd period (cf. below) there were two entrances, one in the N. and another in the E. corner of the fore-court, both provided with short, straight staircases leading to the higher level of the court, but the original arrangements of the 1st period are uncertain as the N. E. wall of the fore-court was entirely demolished in connexion with the rebuildings of the 3rd period (cf. p. 200). There may have existed entrances in the same places as in the 3rd period but this cannot be proved.

From the N. W. short side of the fore-court a wide staircase, once flanked by votive sculptures (cf. p. 277) leads to the altar-court. Two circular and two semicircular altars of the construction described above, p. 174, were erected in this altar-court.

The altar-court and the fore-court were naturally open to the sky; the small room at the back of the fore-court may have been roofed in.

Another, smaller, cult-house was erected immediately to the S. E. of the S. E. store-rooms. The house is rectangular in shape and is divided by a transverse wall into two square rooms (113 and 114), measuring 3.85 m. \times 4.15 m. and 4.15 m. \times 4.15 m. respectively. Both rooms are entered through doorways in their S. E. walls but do not communicate with each other. In the S. W. room (113) a rectangular altar projects from the transverse wall between the rooms.

Remains of a third cult-house were found W. of the palace. The majority of the sculptures are fragments of Herakles figures and the cult-house is therefore called "Chapel of Herakles". Its architecture, as mentioned above, pp. 201 f., is not much known.

Period 2.

MATERIAL AND CONSTRUCTION.

The ashlar walls built in this period are of Type 4, Class B (Walls 42—44); Type 6, Class B (Walls 58—64 A, 65—67); and Type 6, Class C (Walls 41, 68—72); there are only two rubble walls newly built in this period: one (Wall 130) is of Type 13 and the other (Wall 148) of Type 14. The construction of the upper mud-brick walls is shown by the remains of the collapsed mud-brick walls in the store-room 88 and is described above, pp. 145 f.

In the corridor of the sudatory there is a cemented rock-floor of Type 1, while the fuel room 41 where the rock slopes received a pavement of stone slabs on a filling of earth. The newly built store-rooms 86—88, 92, and 93 and the cult-chapel (Room 101) have floors of Type 2.

The cistern which was cut in this period in the open space later occupied by the N. E. part of the large, S. E. court (Room 83) is of the bottle-shaped type and was provided with a cemented basin which served to clear the water from the dirty particles which sunk to the bottom of the basin before that was filled and the water could flow into the cistern.

The most remarkable structure of the 2nd period is Room 85 and the adjoining walls. The room is a rectangular, narrow corridor, 5.50 m. \times 1.00 m., on the long sides enclosed by Walls 63 and 64 A. The walls end in a corbel-vault built over the narrow corridor. As men-

The palace
Façade, Room 93

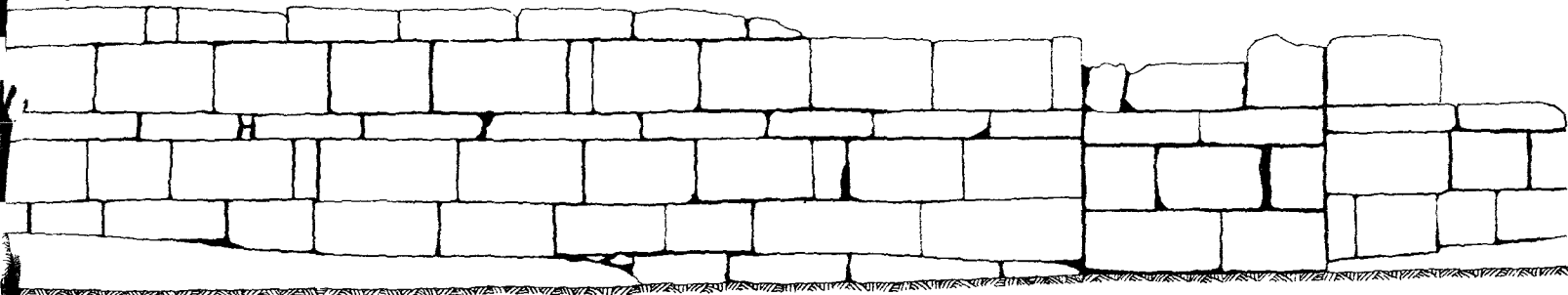

Façade, Room 93

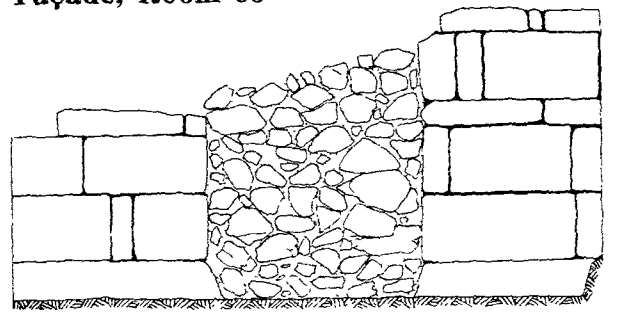

71
2

69
1

Façades, Room 93

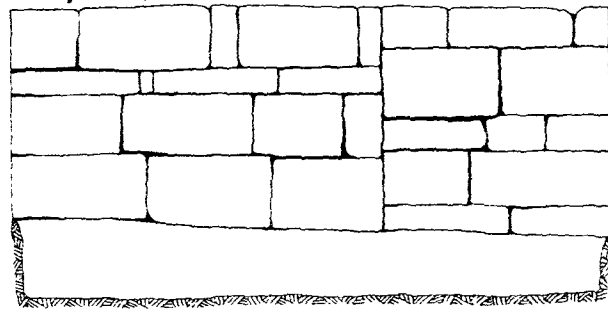

72
3

Façade, Room 93

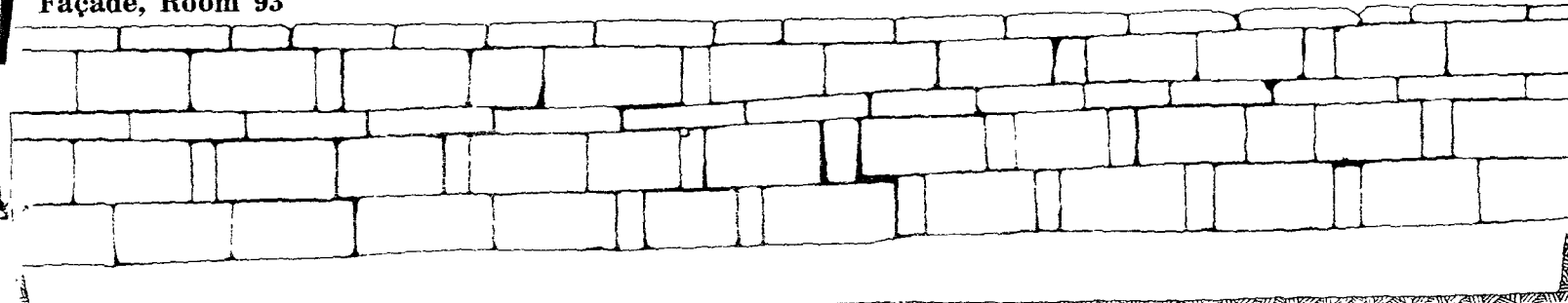

68
4

Façades, Room 126

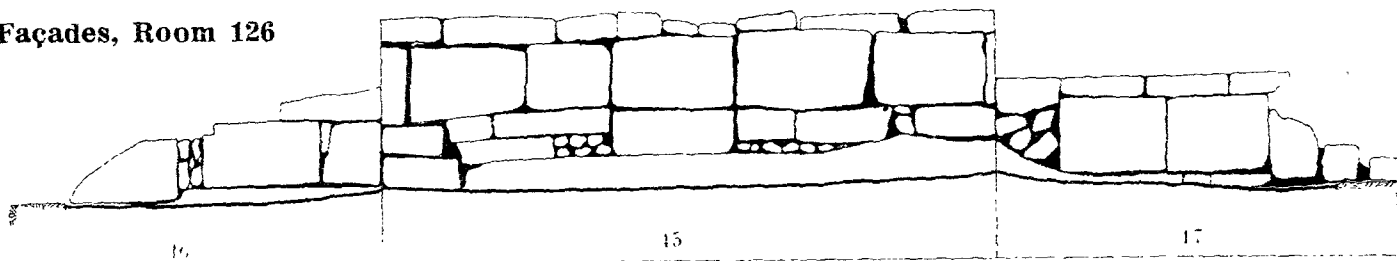

16 15 17
5

Façades, Room 127

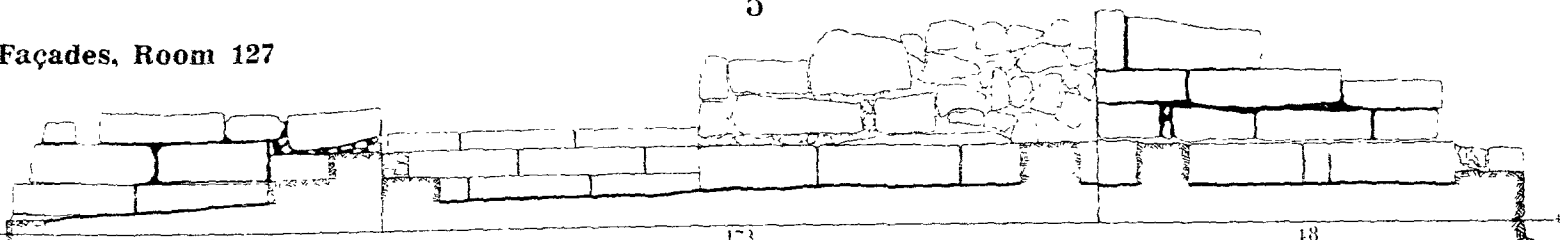

17 173 18
6

Façades, Room 128

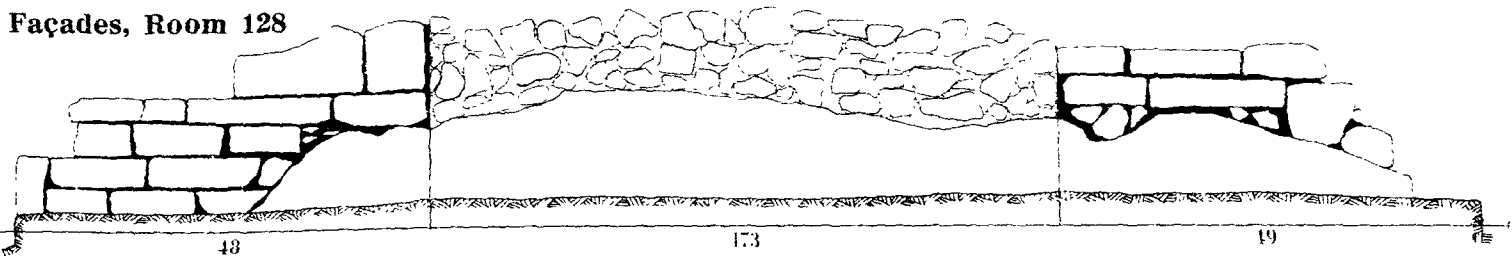

48

173

19

tioned in the description of the walls, pp. 130 f., four small, almost quadratic boxes are built of ashlar blocks in each of these walls, opening on to the corridor and those of Wall 64 A to Room 41 as well. The boxes taper upwards into narrow holes. Ash and carbonized matter were found in the boxes and the corridor (Section XIII) and traces of smoke on the blocks indicate that the boxes were used for firing and the whole structure is accordingly to be interpreted as a heating room from whence the hot air was conducted in the narrow holes to a room above. This upper room thus heated has evidently served as a sudatory added to the already existing bath-rooms 40 and 42 of the 1st period.

All the other structures of the 2nd period are the same or of the same types as in the 1st period.

Form and Plan.

During the second period a suite of store-rooms to the N. E. and S. W. (Rooms 86—88, 92, and 93), a latrine (Room 91) and the sudatory (Rooms 41 and 85) for the bath were added to the palace.

The store-rooms 86—88 are narrow-fronted and of the same shape but Room 86 is narrower than Rooms 87 and 88, Room 86 measuring 4.00 m. \times 5.50 m. and Rooms 87—88 5.00 m. \times 5.50 m. The rooms are entered from the road along the N. E. exterior wall of the palace by doorways in the front wall of the rooms. Besides, there was a door at the right end of the back wall of Room 88 by which there was communication with the open place of Room 83 which in the 3rd period formed the N. E. part of the large S. E. courtyard.

The shape of the store-rooms 92 and 93 differ in shape and size from the preceding ones: they are somewhat wider than Room 86 and somewhat narrower than Rooms 87 and 88 and more than twice as deep, measuring 4.50 m. \times 12.40 m. The rooms are narrow-fronted and are entered by doorways in the middle of their front sides. Besides, there was a door in the S. E. part of Wall 69 by which the rooms communicated direct with each other.

Room 91 has been interpreted as a latrine but this interpretation is not much more than a conjecture, for want of a better explanation. The room is rectangular and built in the angle between the store-rooms 88 and 92. Its construction is described above, p. 132.

The bath was enlarged to a combined hot and cold bath by adding the sudatory (Room 85) to the rooms for rubbing and washing with hot and cold water already built in the 1st period. The component parts of the later Roman bath: the *sudatorium*, *caldarium*, and *frigidarium* are thus represented already in this Cypriote bath of the 5th century B. C. (cf. below, Absolute Chronology, p. 286), Room 85 being the *sudatorium*, Room 42 the *caldarium*, and Room 40 the *frigidarium*. The construction of the sudatory is described above. Probably the sudatory was entered by a wooden stair in the E. corner of the hot water washing room.

By the erection of the S. E. and N. E. store-rooms a courtyard began to be formed to the S. E. of the palace of the 1st period. This courtyard was completed in the 3rd period (cf. below).

At about equal distance from the S. E. and the N. E. store-rooms and the earlier palace,



Fig. 129. Vouni. The palace. View towards the S. W. from Room 31.

a bottle-shaped cistern was cut in the rock. This cistern received water from the roofs of the newly built store-rooms by a conduit descending down Wall 58 approximately in the angle of Walls 63 and 58.

Beside these enlargements of the palace some rebuilding and new arrangements took place in Room 55 and in the kitchen court. The original S. E. wall of Room 55 which ran somewhat obliquely in relation to the other walls of the room was rebuilt and straightened, by which the room obtained a perfectly rectangular shape. In connexion with this rebuilding the original staircase leading from Room 55 to the kitchen court was demolished and a new staircase built somewhat to the N. E. of the earlier one and leading up to the new doorway between Room 55 and the kitchen court.

At the same time this court was divided into two halves by Wall 148 which was built across the court from the N. E. end of the doorway between Room 55 and the court. At the S. E. end of this wall there was a doorway by which communication between the S. W. and N. E. halves of the court was established.

A cult-house (Room 101) was erected to the S. of the palace, on the area between this and the sanctuary on the top of the Vouni rock. The cult-house consists of a single room



Fig. 130. Vouni. The palace. View towards the N. E. from Room 19.

and is almost quadratic in shape, measuring 5.10 m. \times 5.20 m. The entrance is in the S. E. wall. To the right of the entrance there are two orthostatic blocks forming an angle.

Period 3.

Material and construction.

The ashlar walls newly built in this period are of Type 3, Class B (Walls 13 and 14); Type 4, Class B (Walls 21—27, 29—35, 45—49); Type 6, Class B (Wall 64 B); Type 6, Class D (Wall 73); Type 6, Class E (Walls 74—76); Type 7 (Walls 77 and 78); Type 8 (Walls 79—82); Type 9 (Walls 84—91). The rubble walls are of Type 11 (Walls 105, 109—118); Type 12 (Walls 119 B and 120); Type 14 (Walls 142—144, 147, 149—152, 164, 174—178). Besides, the terrace wall 190 (Type 16) was erected in this period.

The upper walls were built of mud-bricks as in the preceding periods. It can be proved that an upper story was added to the palace in this period (cf. below) and on the evidence of the stratified layers of these mud-bricks (cf. pp. 182 ff.), it can be seen that the upper story of the rooms around the central court was built of grey and white mud-brick and the

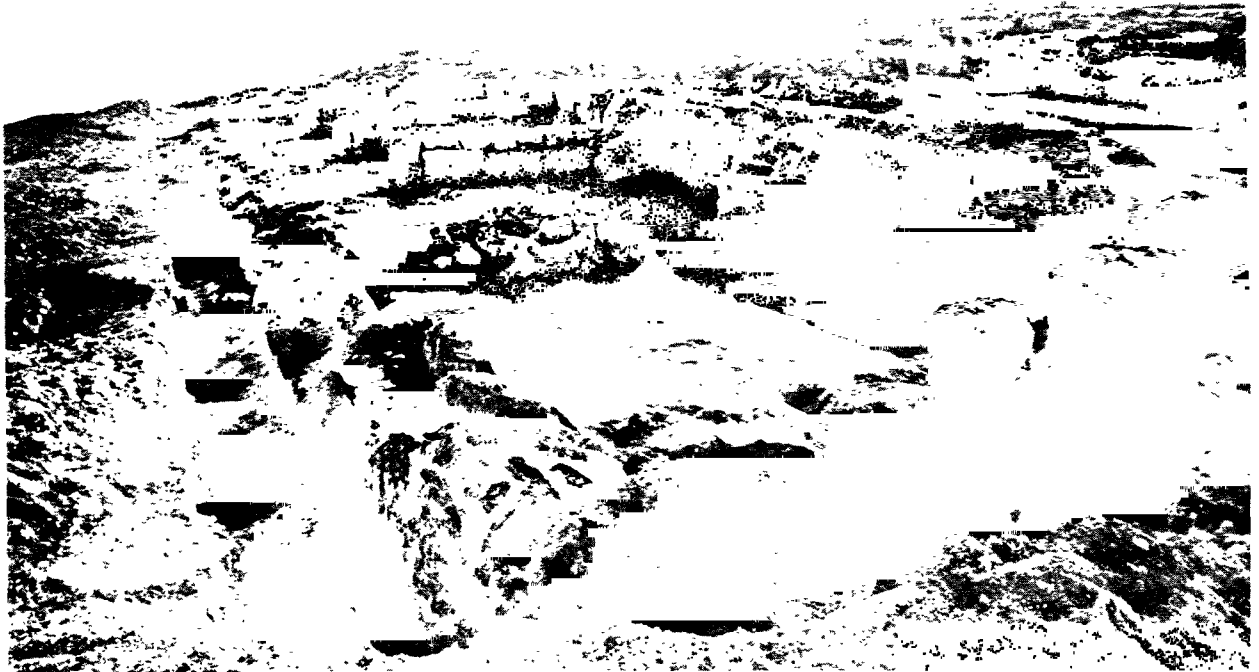

Fig. 131. Vouni. The palace seen from its W. corner. Store-rooms 10—14 in the foreground.

ground-floor of red mud-brick while the contrary was the case with the store-rooms 86—88, whose upper story was built of red mud-brick and the ground-floor of grey and white mud-bricks.

The rooms of the interior part of the palace were as in the earlier period covered with floors of Type 5 (Rooms 28, 53, 60, 73, 74, 76). Besides, there was laid an upper floor in the store-room 92 of this same type, while the other store-rooms newly built have floors of Type 4 (Rooms 95—97). The floors of the cult-rooms and other structures built outside the palace are either of Type 1 (Rooms 103, 117, 126, 128), or of Type 2 (Room 101), or of Type 4 (Rooms 104—109, 127—129, 133—135). The floor of the entrance corridor 57 and the newly laid upper floor in Room 34—35 are of Type 3, and the vestibule 7 A—B has a floor of Type 4; in the earlier kitchen court 64, a second floor of Type 3 was laid, while the floors of the large, S. E. court and the kitchen court 66 which were laid out in this period are of Types 4 and 7.

Where the rock slopes, the floors rest on levelling fillings of earth. Such fillings were necessary below the floors of the newly built vestibule 7 A—B, and in the N. E. part of the large, S. E. court (Room 83), and that accounts for the different structure of the floor in the S. W.

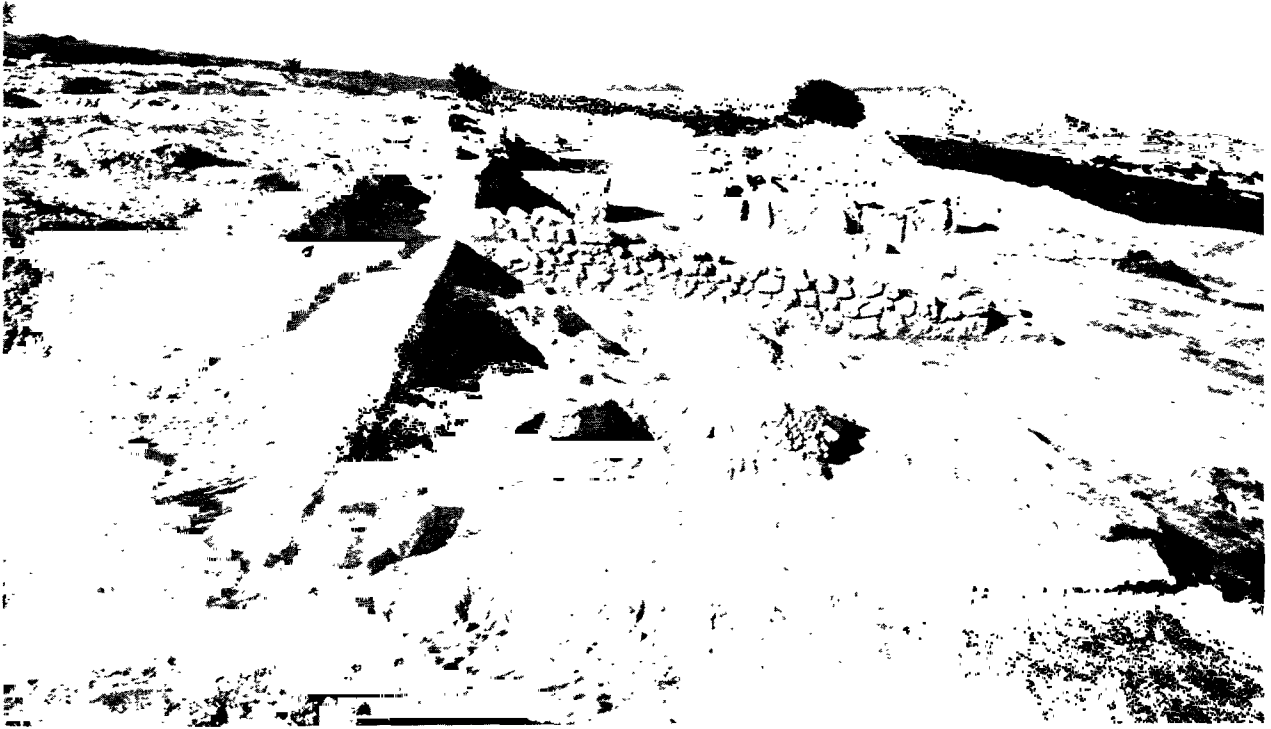

Fig. 132. Vouni. The palace. The N. W. complex of rooms with Room 8 in the foreground.

and N. E. parts of the court: in the S. W. where the rock rises the floor consists of red lime-marl levelling the irregularities in the rock while in the N. E. part of the court the floor-level is only marked by rammed earth on top of the earth filling.

The tank-shaped cistern in the central court was replaced by the double cistern of the bottle-shaped type. Its construction is described above, pp. 165 f. For hoisting the water from this cistern a wooden structure was erected consisting of two wooden stands, placed on opposite sides of the mouth of the cistern, and a revolving cross beam resting on these stands.

The stairs of the straight, short type built in the earlier periods and facilitating communication between the rooms of the ground-floors on different levels, were still used in the 3rd period and other similar stairs were built (in Rooms 7 A, 26, and 46). Besides, two stairs of the long, straight type (in Rooms 17 and 64) and the three-flight staircase in Rooms 59—60 were built. The latter stairs led to the upper story proving that such a story was added to the palace in this period.

All the other structures are the same, or of the same construction as in the earlier periods.



Fig. 133. Vouni. The palace. Part of the kitchen-department seen towards the S. E. from the courtyard 64. Rooms 73—76 in the foreground.

Form and plan.

During the 3rd period the building operations begun in the 2nd period were completed, and beside that, essential parts of the palace were rebuilt, by which its plan and form were entirely changed.

To the S. E. store-rooms (92, 93), a suite of four new store-rooms were added (Rooms 94—97) and three more fire-chambers built in Wall 64 B, and of the same shape and construction as the others, were added to the sudatory. The N. E. part of the kitchen-department (Rooms 78—80) was demolished and the narrow wall which separated these rooms and the S. E. half of the earlier kitchen court was rebuilt into a wall of approximately the same width as the S. E. exterior wall of the 1st period palace and running as a S. W. continuation of that (Wall 147). In this way a large, open courtyard, the S. E. court of the palace, was formed approximately rectangular in shape and enclosed on all the four sides, to the N. E. by the sudatory and store-rooms 86—88, to the S. E. by the store-rooms 92—97, to the S. W. by the kitchen-department, and to the N. W. by the central part of the palace. The court measures 33.0 m. · 16.0 m. and, consequently, it is almost twice as large as the central court; it was not, however, a formal court as that, but served as a backyard for the



Fig. 134. Vouini. The palace. The house outside the S. corner of the palace, with Rooms 107—108 in the foreground.

S. E. storehouse of the palace. It was entered from the outside by a doorway, opening in Wall 29 which was built across the space between the kitchen-department and the S. W. end of the store-room suite. The newly built store-rooms 94—97 are all of the same shape and approximately the same size as the store-rooms 92—93 to which they were added. It is, however, to be observed that the S. E. exterior wall of Rooms 95—97 is not in line with that of Rooms 92—94 but runs 0.30 m. to the N. W., apparently in order to widen the passage between the cult-house (Rooms 113 and 114) and the exterior wall of the store-rooms.

Unlike the store-rooms 92 and 93 of the 2nd period, the newly built store-rooms are entered from the court through doorways in the middle of their front walls. On each side of the doorway of Room 96, there is a projecting piece of wall screening off a small open-fronted area in front of the door.

In connexion with these building operations, some minor rebuildings took place. As Wall 58 had to support the filling of the levelled S. E. court, the doorway leading to Room 88 was blocked up. Another alteration of the earlier condition, which is difficult to

explain, was made in the store-room 93. This was entirely filled in with debris of chipped stones and in consequence, the doorway between Rooms 92 and 93 was blocked up.

Apart from the demolition of Rooms 78—80 in the kitchen-department this underwent several alterations and enlargements. In Wall 148 the earlier doorway through which there was communication between the N. E. and S. W. halves of the kitchen court, was blocked up. The N. E. half of the earlier court which, consequently, became entirely separated from the kitchen-department was then rearranged. Walls 101 and 193 were demolished. Within the N. W. part of the area Walls 149—152 were erected, serving as substructure for a wooden staircase leading to the upper story of the palace, and a doorway was cut through Wall 56 and thus the staircase could be reached from the central part of the palace. From the lower level of Room 46 a stair of five steps leads up to the higher level of the base platform of the three-flight staircase. At the same time, a new floor was laid in the small rooms 61 and 62+63 adjoining the staircase and occupying the space, which was not required by it, within the area separated from the kitchen-department. This floor covered the mouth of the cistern in this part of the earlier kitchen court, and this cistern thus ceased to be used.

In compensation for the demolished rooms of the kitchen-department and the N. E. part of the kitchen court occupied by the staircase and the adjoining rooms, the kitchen-department was enlarged by a rectangular building projecting to the S. W. and consisting of Rooms 71—73, 76, and another kitchen court (Room 66) measuring 6.85 m. \times 11.40 m. Rooms 71 and 72 were built along the S. E. side of the new kitchen court and are entered through doorways opening on to the court, but do not communicate with each other. The rooms are of small size. Room 71 measures 4.30 m. \times 4.80 m. and is consequently almost quadratic in shape. Room 72 is narrow-fronted and measures 3.20 m. \times 4.35 m. At the erection of Room 73, the S. E. part of Room 74 was occupied by the new room and the walls of Room 74 within this occupied area were demolished. In this way Room 74 was made a very small, almost quadratic room, measuring only 2.60 m. \times 2.65 m. It communicated with Room 73 by a doorway at the N. E. end of Wall 32. Room 73 is almost quadratic in shape and measures 4.00 m. \times 4.35 m. It communicates with Room 76 through a doorway in the middle of its N. E. wall and its floor slopes towards this door. Room 76 is very small, measuring only 2.40 m. \times 2.80 m. Its floor slopes towards an outlet of a drainage channel in Wall 30 and in its E. corner is a rectangular sink of stone slabs, measuring 1.25 m. \times 0.60 m., and built into a rectangular platform of rubble along Wall 142. This sink was filled with broken pottery. It is thus evident that Rooms 73 and 76 were sculleries.

The kitchen itself underwent the alteration that Wall 95 was demolished, so that the two earlier rooms of the kitchen were transformed into one. In connexion with this rebuilding a new floor was laid, but this has been almost entirely destroyed and of the hearth of this rebuilt kitchen no traces were left.

In the remaining part of the earlier kitchen court (Room 64) a second floor was laid and the stair leading from Room 55 was increased by one step in order to reach the level of this new floor. At the same time a staircase of the long, straight type, leading to the upper story

of the newly built rooms of the kitchen-department was erected along the N. E. wall of the court. The staircase landed on the roof of the kitchen whose narrow, and not very solid walls cannot have supported an upper story, and from this roof, the upper story of the newly built rooms was entered.

As the cistern in the earlier kitchen court was covered by the new floor in Room 61, and thus ceased to be used (cf. above), the water from the roofs of the rooms of the kitchen-department, which in the earlier periods was received by this cistern, had to be collected in another cistern, and for that purpose a new cistern was cut in the rock, outside the palace at some distance from the W. corner of the kitchen-department.

In the S. W. wing of the palace, too, some minor rebuildings were carried out. In the western vestibule (Room 14), the staircase leading to the upper story of the store-rooms was demolished, the exterior doorway of the room was blocked up, Wall 8 which separated the vestibule from the store-room 13 was demolished, and another wall (76) was built in the place of the demolished staircase. In this wall, a doorway opened into the store-room 13, and in that way the earlier vestibule was transformed into a store-room adjoining those of the earlier periods. Room 28 which had been open to the sky before was roofed-in and a new floor was laid in the room. The drainage channel in which the rain-water falling on the floor of the room had been carried off became superfluous, when the room was roofed-in, and its outlet in Wall 12 was therefore blocked up. Furthermore, direct communication was established between this room and the open passage room 26, through a doorway in the N. corner of the room to which a short staircase of three steps leads from the lower level of Room 26.

The ramp (Rooms 17—18) leading from the N. entrance of the western wing of the palace to the open court of this wing (Room 19), was separated from the court by a transverse wall (105), so that the court and the ramp only communicated through a narrow doorway at the N. W. end of the wall. The erection of this wall seems to indicate that the ramp was now roofed-in, because it is difficult to explain the purpose of this wall if not to support such a roof covering the ramp.

The staircases leading from Room 31 to Room 32, and from that room to Room 33 were rebuilt into one united staircase with the two flights of steps from both Room 31 and 32, ending in a common landing place in front of the door to Room 33. At the same time, the floors of Rooms 30—31 were repaired in connexion with the construction of a water-conduit leading the water collected on the roofs of the rooms N. W. of the central court and running below these floors to the cistern in Room 19 (cf. below).

Finally, a staircase of the long, straight type was built in the N. W. part of Room 17 along Wall 18. This staircase led to the upper story of the palace, to a room above the vestibule 16.

In connexion with this, the water-basin in the open space between the inner face of Wall 17 and the N. E. end of Wall 18 and the water-conduit descending from the earlier roof of Room 16 were demolished. These fell out of use when the roof of Room 16 by the upper story added was made level with, or even somewhat higher than that of the upper



Fig. 135. Vouni. The palace. The S. E. court from the S. W.

story of Rooms 10—14, as the floors of these rooms are somewhat below that of Room 16. The water collected on the roof of the upper story of this room could therefore be carried across the roofs of Rooms 10—12 to the cistern in Room 19 (cf. above, p. 210).

More important rebuildings were carried out in the central part of the palace. A new principal entrance with a large, angular vestibule (Room 7 A+B) was built around the N. corner of the palace. This vestibule was approached by means of a short, sloping ramp of rammed earth (Room 8) supported by Wall 109, and was entered through a wide gate, measuring 3.10 m. in width, with a threshold of stone blocks and door-jambs resting on rectangular bases of small slabs of stone. From the S. E. end of this angular vestibule one ascended to the higher level of Room 37 by means of a staircase of nine steps, 7.70 m. in width, and extending across the whole width of the vestibule, and from Room 37 the central court was entered.

At the same time the S. W. open hall of the earlier principal entrance leading direct to the state apartments was closed by a transverse wall (73), and a floor of lime-cement of the same kind as in the other adjoining rooms of the state apartments was laid in this enclosed room. Otherwise the state apartments remained untouched, but by this simple rebuilding



Fig. 136. Vouni. The palace. The N. E. part of the S. E. court (Room 83) with Room 84 in the foreground, Rooms 86—88 to the left, Rooms 92—94 in the background, and the cistern to the right.

their architectural character was completely changed. From being located in the entrance building and accessible direct from the exterior, they were relegated to the back of the central court, and transformed into a megaron-shaped central part, flanked on each side by three side-rooms.

Behind this building, a corridor (Room 57) was made by the erection of Wall 34. In the E. corner of the corridor, a short stair was built leading to a doorway opening on to the new kitchen court (Room 66).

The earlier main room of the private apartments (Room 34+35—36) was divided into two rooms by the erection of Walls 74 and 75, and a new floor was laid in Room 34+35 covering the mouth of the well-shaped cistern which was filled in and partly cut off by Wall 74. Though the walls of the corresponding rooms on opposite sides of the central court, as pointed out above, are not placed opposite each other, and the rooms are of different size, the earlier, asymmetrical arrangement was in this way largely adjusted and a symmetrical aspect was to be attained.

Finally, the earlier, tank-shaped cistern in the central court was rebuilt. It went out of use when the well-shaped cistern from where the water was drawn, was filled in (cf. above),



Fig. 137. Vouni. The palace. Room 111 of the house outside the S. corner of the palace.

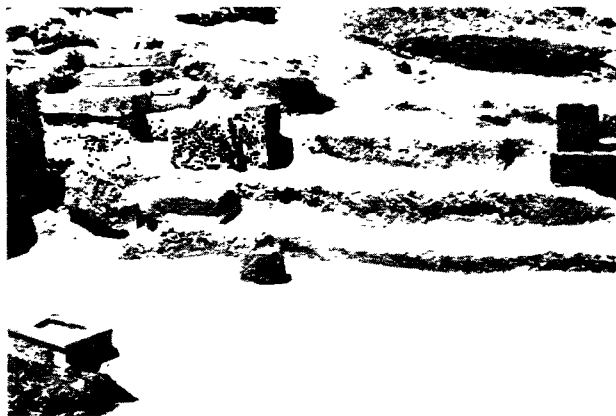

Fig. 138. Vouni. The palace. The entrance into the altar-court (Room 123) of the main temenos with bases for statues *in situ*.

and was replaced by a deep double-cistern of the bottle-shaped type, the lower cistern being cut in the rock from the bottom level of the N. E. part of the tank-shaped cistern, and the upper cistern built of stone blocks on top of the lower one in the technique of a corbel-vault. It was certainly intended to give this new cistern a superstructure of some kind, but this work was not finished when the palace was destroyed (cf. below, p. 191). Preliminarily, two wooden stands were erected in this period on opposite sides of the mouth of the cistern; a revolving cross-beam probably rested on these stands for hoisting up the water from this deep cistern.

The cistern received water from the roofs of the rooms S. E. and N. E. of the central court as before, and from the roofs of the newly built rooms adjoining the three-flight staircase and the S. E. side-rooms of the state apartments, too, from which the water in the earlier periods was probably carried to the cistern in the earlier kitchen court which now was filled in and covered by the floor of Room 61 (cf. above). The water from the roofs of the rooms N. W. of the central court was not, however, conducted to this cistern, as shown above, p. 199, but was carried in a conduit below the floors of Rooms 30 and 31 to the cistern in Room 19.

The building operations of this period not only consisted of these rearrangements and of horizontal enlargements but of *vertical* enlargements, too: an upper story was now added. As pointed out above, the earlier palace had no upper story apart from that above the N. W. store-rooms, which, however, was on a level with the ground-floor of the adjoining parts of the palace. In the 3rd period an upper story was added to the central part of the palace, the kitchen-department and the store-rooms 86—88, 92, 93, while the store-rooms 94—97 were probably without an upper story, as on account of the rising rock, their ground-floor is approximately on a level with the floor of the upper story of Rooms 86—88, 92, 93 whose ground-floor was partly cut in the rock. That an upper story was added to these parts of the palace is shown both by the fact that stairs leading to this upper story were built in this period, and by the stratigraphic evidence of the collapsed mud-brick walls which were built

of different kinds of mud-brick in the ground-floor and the upper story, as clearly shown by the stratification (cf. pp. 215 and 217).

In this way the palace obtained its ultimate form, which the minor additions and rebuildings of the 4th period did not change. This ultimate form differs essentially from that of the earlier palace, owing to the changes in its central part, because these changes, unlike all the others, affect the architectural principles. The axiality is preserved, though not in the entrance which on account of the steep slope of the rock to the N. E. had to be located as it is; the symmetry is still more emphasized — these features are in accordance with, or not opposed to, those of the earlier. The location of the state apartments in the back of the central court, however, and their megaron-shaped, principal room make the architectural form of the palace of the 3rd period quite different from that of the earlier periods (cf. Vol. IV).

Outside the palace some new structures were erected: to the main temenos a state façade was added consisting of the three rooms 126—128, all with open fronts where the roofs were supported by columns, as shown by some of their bases being preserved, and the middle room (127) provided with a platform of a single row of rectangular stone slabs along the base of its walls. While the courts of the temenos were open, these facing rooms were thus roofed-in.

The stairs leading to the E. and N. corners of the fore-court of the temenos were rebuilt as far as they existed in the earlier periods (cf. p. 200), and obtained their present appearance.

Along this façade of the main temenos, a road was laid on a deep terrace filling of earth supported by Wall 190. In this road there is a cistern which received water from the roofs of the covered rooms of the temenos; the water was conducted to the cistern in a cemented water-conduit which has been destroyed, and in the 4th period was replaced by the still preserved conduit descending along the staircase leading from the road to the E. corner of the fore-court of the temenos (cf. p. 200).

To the W. and S. of the main temenos two chapels were erected. The chapel to the W. consists of a quadratic, screened off area (Room 132) at the entrance to the chapel, a fore-room (133) entered through a door at the left end of its front wall, the inner room (134) entered from the fore-room through a door in the middle of its front wall and provided with a small, quadratic recess (Room 135) in its back wall. The rooms are rectangular in shape. Room 134 measures 4.85 m. \times 5.45 m. and Room 133 is 3.35 m. \times 4.90 m. The latter room has a revetting platform of stone slabs along the base of the inner faces of its walls, as Room 127 of the main temenos.

The chapel to the S. of the main temenos consists of a single room (117) and a corridor (Room 118) along its N. wall. The room is rectangular in shape, measures 5.30 m. \times 6.60 m., and is entered through a doorway in the middle of its front wall flanked by projecting pieces of walls. In the middle of the chapel there is an altar of the square type.

Outside the entrance vestibule, three small rooms enclosed by angular walls (Rooms 1—3) were built along the outer face of Wall 120. Their purpose is not certain. In Room 3 there



Fig. 139. Vouni. The palace. View of the main temenos from the S. E. Drainage channel to the left, the fore-court and the altar-court to the right.

is a small, square base, possibly an altar. The rooms may be interpreted as enclosed roadside altars erected at the entrance of the palace.

Outside the S. corner of the palace, a building of an irregular form was erected. It contains seven rooms (103—109) which form a structural unit, but the rooms are of an irregular, trapezoid shape and are not joint to each other in the same, strictly regular system as is typical of the palace architecture. The purpose of the building is uncertain. In Room 106 there is a cemented water-basin along Wall 113 indicating that the room was used for washing. Rooms 107 and 108 were separated by a wooden wall framed with wooden poles and in Room 109 there was a bench of earth supported by a row of stone slabs along the N. E. wall of the room.

Period 4.

Material and construction.

Only two ashlar walls were built in this period: one (Wall 28) is of Type 4, Class B, and the other (Wall 83) is of Type 9. The rubble walls newly built in this period are of Type 14 (Walls 139—141, 145, 146, 153—155, 167, 168, 169 B) and of Type 15 (Walls 179—189).

The floors of the rooms added to the palace and the structures outside the same are of the following types: in the store-room 98 and Rooms 124—125 added to the main temenos



Fig. 140. Vouni. The palace. The front rooms of the main temenos with Room 129 in the foreground.

there are floors of Type 1; in Rooms 67, 68, 69, and 110 the floors are of Type 4, and in the corridor 57 a second floor, in the kitchen court 66 a second floor, and in the kitchen court 64 a third floor of the same type were laid. Room 84, finally, had a floor of rammed earth.

The other architectural elements are of the same construction as in the earlier periods.

F o r m a n d p l a n.

During the 4th period only minor enlargements and rebuildings took place.

The back wall of the central part of the state apartments was strengthened by a revetting wall of rubble (Wall 155), and a second floor was laid in the corridor 57.

The doorway of Room 43+44 was blocked up, and the room itself was divided into two rectangular rooms by a separating, transverse wall of rubble (Wall 183). These rooms, consequently, could not be entered from the ground-floor. Wooden staircases along Wall 183, however, served as communication with the upper story.

Room 34+35 was divided in two rooms, too, by Wall 182, but here a doorway at the S. W. end of the wall opened between the rooms.

Works were carried out on the cistern in the central court. A superstructure around the mouth of the cistern was being constructed and the wooden stands of the hoisting structure



Fig. 141. Vouni. The palace. Room 127 of the main temenos, seen from the East.



Fig. 142. Vouni. The palace. The cult-chapel, Room 117.

were to be replaced by sculptured stelae of stone, but these works were unfinished when the palace was destroyed.

In the western wing of the palace a part of the court was screened off by Wall 181. This seems to indicate that the area in front of the staircase leading to the upper story of the N. W. store-rooms was now roofed-in in the same way as the ramp in the 3rd period. Only the N. E. part of the court (Room 19) thus remained open to the sky in the 4th period.

Parts of the S. W. kitchen court (Room 66) were screened off by the erection of the small rooms 65, 67, 69. Of these, Room 68 was a washing room, which is evident from the fact that its floor slopes towards an outlet in its W. corner, where a drainage channel cut in the rock carried off the water. In the S. W. kitchen court (Room 66) a second floor and in the N. E. kitchen court (Room 64) a third floor were laid. In connexion with this a fifth step was added to the staircase leading from Room 55 to the N. E. kitchen court in order to reach the raised level of its third floor.

To the suite of the six S. E. store-rooms, a seventh store-room (98) was added and between this store-room and the kitchen-department a vestibule (Room 100) to the S. E. court was built by the erection of Wall 28. The exterior doorway of this vestibule was closed by double doors which turned on pivots and were fastened by bolts. Its jambs were sunk in rectangular shallow cavities in a threshold of stone slabs.

The doorways of the store-rooms 95 and 96 were narrowed by stone blocks and rubble added to their flanks.

In the N. corner of the S. E. court Room 84 was built. This room forms a part of the bath. Its earthen floor was covered with ash and carbonized matter and it seems to have been used for heating the water used for washing in the *caldarium*. Between Rooms 42 and 84 there is a large hole, 0.58 m. 0.64 m., that has been cut right through the wall. The hole is coated with lime-mortar (cf. p. 125) and there are impressions in this mortar showing that some kind of object was once inserted there and fixed by the mortar. The stone blocks around

the hole are much blackened by smoke, and this indicates that the place was used for fire. It may then be suggested that a metal kettle was placed in the hole, and that water poured into that kettle was heated to be used for washing in the *caldarium*. By this arrangement, the bath was completed: the water to be used for washing in the *caldarium* was no longer brought there from the kitchen but was heated in the bath.

Outside the palace, too, some minor building operations were carried out. Two rooms (124 and 125) were added to the main temenos. Room 124 enclosed an area to the N. W. of the earlier temenos and Room 125 was built to the S. E. of the staircase leading to the E. corner of the fore-court. It has an open front whose roof was supported by three columns in the same way as in Rooms 126—128 and it is built as a counterpart to these, but it is of an irregular shape, its walls being built obliquely to those of the earlier temenos. In connexion with the erection of this wall the conduit carrying the water from the roofs of the covered rooms of the temenos to the cistern in the road along its main façade was destroyed and replaced by another conduit, now preserved, and running down the S. E. side of the steps of the staircase leading to the E. corner of the fore-court of the temenos.

Finally, an eighth, irregular room (110) was added to the building outside the S. corner of the palace. In the middle of this room there are two square bases and near the N. E. wall, there is a double row of orthostatic blocks. The purpose of these structures is uncertain as well as that of the whole building (cf. pp. 174 f.).

FINDS

OBJECT REGISTER

1+30.

- | | |
|---|---|
| <p>Torso of female statue with r. arm bent across breast, the hand holding some object; l. arm slightly advanced at side of body; prominent breasts; himation over both shoulders covering both arms and falling in double flaps below waist; spirally twisted bracelets around upper arms; traces of necklace over breast. Fragment of base with feet (No. 30) and some drapery of dress. Much worn, and parts missing. Life-size. Found before excavation.</p> <p>2. Fragment of lower part of female statuette, similar to No. 1. Fringed border on himation. Upper part with r. arm and part of legs missing. Found in pieces; the feet do not join directly. White limestone. Height 43.5. Found before excavation.</p> <p>3. Small fragment of a female statuette. White limestone. Height 5.0. Found before excavation.</p> <p>4. Base and feet, belonging to No. 16. Found before excavation.</p> <p>5. Torso of a male statue with l. leg advanced; r. arm was outstretched and free from body; l. arm slightly bent beside body; vertically folded chiton; folds rendered by narrow grooves; himation over l. shoulder with shallow, curved folds obliquely across body. Head, neck, r. arm with hand, l. hand, and legs from above knees missing; partly worn. White limestone. Height 117.0. Shoulder</p> | <p>width 60.5. Waist width 36.5. Breast to back 24.5. On the surface W. of the palace.</p> <p>6. Torso of male statue with l. leg slightly advanced; l. arm slightly bent beside body; chiton with short sleeves; plain himation over l. shoulder with marked border obliquely across breast; the end of the garment falls behind the l. shoulder. Iron dowels passed vertically through the lower parts of the legs. Head, neck, r. forearm, l. hand, and feet missing. White limestone. Height 132.0. Shoulder width 54.5. Waist width 34.5. Breast to back 22.5. On the surface W. of the palace.</p> <p>7. Bronze mounting with impressed ornaments of palm-ettes and volutes; pierced by four holes. Slightly damaged. Length 3.1. Room 14. Floor.</p> <p>8. Fragment of a statuette; only part of l. arm and part of body preserved. Traces of colour on borders of himation. White limestone. Height 15.0. Stray find.</p> <p>9. Two fragments of a Red Figured Attic amphora with one field of decoration framed by vertical, dotted bands and transverse bands of kymation ornaments on each side of body between the handles. On one side, the head and shoulder of an ephebos looking to the l.; dressed in a folded himation and with a purple taenia around the head; eye <i>en face</i>; on the other side, the upper part of a woman looking to the r.; dressed in chiton and folded himation; hair bound up in a veil; holding an apple</p> |
|---|---|

- in her r. outstretched hand; facing her has been a male figure of which only the top of head and one outstretched arm resting on a thick stick or club remains. The scene evidently represents Herakles fetching the apples of the Hesperides. Found in the debris below floor-level of the S. E. court.
10. Roughly oval loom-weight of terracotta, tapering towards the pinched top which is pierced by a hole; flattened base. Height 3.0. Room 83. Debris below floor-level.
11. Fragment of a mounting of bronze leaf with one folded edge preserved. Length 5.3. Room 83. Debris below floor-level.
12. Fragment of r. hand of terracotta. Ring finger, little finger, tips of second and third finger missing. Traces of a bracelet around wrist. Dark red clay. Length 11.0. Room 122. Deposit of sculptures.
13. Fragment of feet of terracotta wearing shoes with pointed end; most of inner side missing. Length 12.0. Room 122. Deposit of sculptures.
14. Fragment of the folds of a himation with fringed borders, similar to those of No. 2. White limestone. Height 23.0. Found before excavation.
15. Fragment of head belonging to a life-size statue of terracotta; only face and front of neck preserved. The face is similar to No. 52+53+60 b and made in the same mould; necklace with bead-shaped pendant. A triangular piece in the middle of forehead missing; eyebrows, lids, and iris painted black; bright-red clay. Height 23.5. Room 122. Deposit of sculptures.
- 16—4+24 a—25.
Life-size kore statue standing with l. leg advanced on a trapezoid base; naked feet with sandals with rather thick soles, one strap across toes, one passing between the great toe and the next, one passing round the ankle, and one around the heel (base and feet=No. 4); double anklets around ankles; l. arm slightly bent; its hand has held some folds of the dress; oval head (No. 25) with strong, rounded chin; smiling mouth with softly rounded lips; full, smooth cheeks; almond-shaped eyes with lids, placed horizontally; diadem consisting of two rows of rosettes in relief around head; the hair in front is parted in the middle, the curls rendered by parallel notchings separated by curved, incised lines; falling at back of head in contiguous plaits, and in detached plaits on shoulder along the neck leaving the carefully sculptured ears visible; earrings with rosettes in relief, necklace rather high up around neck; linen chiton and woollen mantle draped over l. shoulder and falling with curved, oblique folds over body and gathered in two vertical groups along l. leg and r. side; the wool is rendered by a picked surface and thin zigzag notchings. R. arm and shoulder, l. forearm with hand, part of dress at l. side, and nose missing; broken in six pieces; breast much worn. White limestone. Height (base included) 162.0. Height (without base) 154.0. Shoulder width c. 35.0. Front to back 20.5. Waist width 23.5. Hips width 29.3. Head height c. 23.5. Length 24.3. Width 16.0. Feet length 23.5. Base 26.0×38.0. Room 122. Deposit of sculptures.
17. Female head belonging to a life-size statue; oval face with strong, prominent chin and cheeks; vivid smile on lips; long, narrow, pointed nose in line with forehead; lancet-shaped eyes, placed slightly obliquely; sculptured eyelids; curved eyebrows; one row of spiral-shaped curls over forehead; a spirally twisted curl with upturned end falls vertically before each ear; mass of wavy hair at back of head; diadem around head; on the diadem, a frieze in relief consisting of eight figures running to the left with bent legs in profile, body and head *en face*; uplifted, outstretched arms and joined hands; in their interstices two rosettes, one placed above the other, with marked petals and central knob; above the heads of the figures fragments of some ornaments are visible, probably lotus buds or flowers; below the frieze, one row of kymation ornament; elaborate, spiral earrings with pendants covering the ear; traces of necklaces. White limestone. Total height 28.0. Head height 23.5. Length 17.0. Width 16.0. Nose length 5.5. Eyes length 3.5. Room 122. Deposit of sculptures.
- 18—92.
Upper part of female statuette (No. 18), with r. arm bent over breast, its hand holding small object (fruit?) in front of r. breast; oval, rather broad head (No. 92) with eyes of myrtle-leaf shape; hair falls in a spirally twisted curl before either ear; on top of head it is rendered by radiating grooves and falls at back of head in plaits along sides of neck; thick, torus-like wreath around head; double necklaces around neck, hanging down over breast. Broken off below r. arm; chin, mouth, and nose missing; l. side of face damaged. White, soft limestone. Height 19.5. Shoulder width 18.5. Breast to back 5.2. Head height 7.9. Length 6.7. Width 6.4. Room 122. Deposit of sculptures.
19. Moulded, female head of terracotta with oval face; straight mouth; nose in line with forehead; eyes of myrtle-leaf shape with modelled lids and eyebrows; hair parted in the middle and arranged in curls; the head is slightly bent to the right. Buff clay. Height 4.5. Room 122. Deposit of sculptures.
20. R. hand and part of arm, belonging to a more than life-size statue; the hand rests on a square, moulded object, which might be a knob of a chair, and grasps a now missing object; bracelet around wrist with small gap between the ends, one end decorated with calf's head, the other with goat's head (cf. No. 292 e, f, g); one ring with oval bezel on the thumb, and two similar ones on each of the ring- and little finger. Ends of fingers missing. White limestone. Length 24.0. Room 122. Deposit of sculptures.
21. Fragment of the hanging folds at the l. side of a statue. White limestone. Height 32.5. Room 122. Deposit of sculptures.
22. Fragment of head; only forehead preserved with high

- hair-dress. Details worn away. White limestone. Height 13.2. Room 122. Deposit of sculptures.
23. Fragments of r. hand, belonging to a life-size statue; one fragment comprises fruit and tips of three fingers; the other comprise parts of fingers with rings. White limestone. Length 17.0. Room 122. Deposit of sculptures.
24. a) Fragment of r. side of statue, belonging to No. 16.
b) Base with feet of limestone; parts missing. Height 7.5. Room 122. Deposit of sculptures.
25. Head, belonging to No. 16. Room 122. Deposit of sculptures.
- 26 + 27.
Female torso, as No. 495. Surface much worn. White limestone. Height 64.0. Room 122. Deposit of sculptures.
- 28 + 40 + 45.
Female statuette with l. leg slightly advanced (feet and legs = No. 45); standing on a roughly square base; body (No. 40) and dress as No. 61, but with more elaborate folds of himation; oval head (No. 28) with slightly smiling lips; rounded chin and cheeks; nose in line with forehead; eyes of myrtle-leaf shape; the front-hair is parted in the middle, the curls rendered by four rows of parallel notchings; ears with large rosette-shaped earrings; bonnet-shaped hair-dress ending in small knot and wrapped up by bands; necklace around upper part of neck. Hair, eyebrows, and iris painted black; hair-bands, centre of earrings, nostrils, lips, necklace painted red. Broken at neck and below knees; l. forearm missing. White limestone. Height 34.7. Shoulder width 9.7. Breast to back 4.2. Waist width c. 5.5. Head height 5.0. Length c. 4.5; (with hair-dress) 5.5. Width 4.0. Room 122. Deposit of sculptures.
29. Fragment of hair and hair-dress, belonging to a large statue; hair falling at back of head in vertical rows of spirally twisted curls. White limestone. Height 12.0. Width 30.0. Room 122. Deposit of sculptures.
30. Base with feet, belonging to No. 1. Room 122. Deposit of sculptures.
- 31 + 32.
Torso of a female statuette, similar to No. 520, but front of body flatter, folds of the himation rendered by more curved grooves, and vertical folds of chiton visible below himation. Traces of red on borders of himation. Head and neck missing; shoulders much worn. White limestone. Height 32.0. Room 122. Deposit of sculptures.
33. Fragment of r. side of face of terracotta with rounded, protruding chin; smiling, protruding lips; full cheeks; strong nose; almond-shaped eyes with painted iris and lids; painted eyebrows; bulging forehead. Buff clay. Height 8.5. Room 122. Deposit of sculptures.
34. Fragment of a dove with outstretched wings. Most of both wings missing. White limestone. Length 6.0. Room 122. Deposit of sculptures.
35. Head of terracotta, as No. 485. Height 4.5. Room 122. Deposit of sculptures.
36. Head of terracotta, as No. 485. Height 4.7. Room 122. Deposit of sculptures.
37. Fragment of upper part of terracotta head, broken off below mouth; small, slightly smiling mouth placed just below nose; long, prominent nose with marked nostrils; eyes almost worn away; marked, arched eyebrows; rows of spiral-shaped curls over forehead; outstanding ears, almost seen *en face*. Only fore-part preserved. Red clay. Height 8.0. Room 122. Deposit of sculptures.
38. Statuette of terracotta, as No. 49. Neck and head missing. Height 15.0. Room 122. Deposit of sculptures.
39. Upper part of female terracotta statue with tubular body, oval in section; prominent breasts with marked nipples; r. arm might have been bent across breast; oval head with prominent chin; smiling mouth; almond-shaped eyes with painted lids and iris; ridged brows; thin, straight nose; bulging forehead; curls of hair over forehead rendered by two rows of shallow holes; head covered by plain veil; thin plaits falling along the shoulders on either side; from r. elbow hangs a vertical fold of the dress along body, and traces of a similar one are visible along the l. side; another fold of the dress is visible below l. breast; two necklaces of pellet beads around neck. Put together from many fragments and partly restored. Eyes, brows, hair painted in black, body in red. Ears missing. Reddish clay. Height 88.0. Shoulder width 48.4. Body width 24.0. Head height 19.5. Width 15.0. Room 122. Deposit of sculptures.
40. Torso, belonging to No. 28. Room 122. Deposit of sculptures.
41. Statuette of terracotta representing seated dog on small base; pointed nose; slightly bulging eyes; small, erect ears. Part of base missing. Buff clay. Height 6.8. Room 122. Deposit of sculptures.
- 42 + 74.
Terracotta statuette with moulded head; representing a woman sitting on a throne (No. 74) with plain sides and back, her feet resting on a footstool; l. arm bent, resting along side of body; r. forearm missing; oval head (No. 42) slightly bent to the r.; rounded chin; the corners of the mouth are lowered, giving the face a melancholy expression; long, thin nose; narrow eyes with marked lids and eyebrows; wreath around head; curled hair rendered by small pellets; plain rosettes in the ears; vertically folded chiton reaching down to feet; himation falling over l. shoulder, and wrapped around waist, covering lower part of body and l. arm; roughly modelled and incised folds. Square back-hole. R. forearm, l. hand, front part of footstool and base missing. Buff clay. Height 26.5. Room 122. Deposit of sculptures.
43. Head, belonging to No. 47. Room 122. Deposit of sculptures.
44. Fragment of terracotta statuette, as No. 493. Only lower part of body preserved; base missing. Buff clay. Height 11.0. Room 122. Deposit of sculptures.

45. Feet and legs, belonging to No. 28. Room 122. Deposit of sculptures.
46. L. hand holding apple, belonging to a statue, slightly less than life-size; the fruit is held by the thumb, the index, and the middle finger; the latter placed across the ring finger. White limestone. Length 10.3. Room 122. Deposit of sculptures.
- 47 + 43.
Female statuette standing on trapezoid base; isolinear feet; r. arm bent across breast, its hand holding flower below r. breast; l. arm slightly advanced, with clenched hand; bracelet around l. wrist; chiton with long sleeves; himation over both shoulders with folds only vaguely indicated by shallow grooves; short, broad neck; oval head (No. 43) with rounded chin and cheeks; slightly smiling mouth; nose in line with forehead; large eyes of myrtle-leaf shape; curls of hair over forehead rendered by rows of parallel notches; hair on top of head rendered by radiating grooves; necklace around neck hanging down over breast. Broken at neck. White limestone. Height 37.0. Shoulder width 10.2. Front to back 5.4. Waist width 8.3. Head height 6.4. Length 6.4. Width 5.0. Room 122. Deposit of sculptures.
48. Fragment of male head; forehead and most part of face missing. Plain, disc-shaped ears; hair on crown of head rendered by radiating grooves; long hair at sides of neck, the curls rendered by zigzag notches; hair over forehead visible at r. temple, the curls rendered by rows of parallel notches. White limestone. Broken below neck; worn. Height 11.0. Room 122. Deposit of sculptures.
49. Moulded statuette of terracotta representing woman standing on high base with moulded edge; l. leg advanced; r. arm bent over breast, its hand touching r. breast; l. arm bent across waist, its hands visible below some folds of himation; sloping shoulders; small, oval face; hair over forehead rendered by a row of curls falling at either side of neck; plain diadem and bonnet-shaped hair-dress; chiton with sleeves; himation over l. shoulder and wrapped around waist in a thick mass of folds from below r. elbow and supported by the l. wrist and hand; vertical folds along legs. Nose and r. foot missing; r. side of face damaged. Buff clay and slip. Height 19.0. Room 122. Deposit of sculptures.
50. Fragment of l. arm with hand belonging to a life-size statue. Around wrist, a bracelet of which ends are decorated with calves' heads (cf. No. 292 e, f, g). Fingers of hand missing. White limestone. Length 23.0. Room 122. Deposit of sculptures.
51. Moulded terracotta statuette representing a woman sitting on a chair with a child on her knee; sides and back of chair are plain; her feet rest on a footstool; r. arm bent, its undigitated hand rests on child's legs; l. arm bent around the back of child; sloping shoulders; long neck; oval head with rounded chin; slightly smiling mouth; nose in line with forehead, eyes with marked lids and eyebrows; hair over forehead rendered with modelled curls; plain diadem around head; bonnet-shaped hair-dress; a notched plait hanging down on either side of neck to shoulders; the dress falling in finely modelled folds along the legs; the garment is rather worn on upper part of statuette. Square back-hole. Buff clay. Height 18.0. Room 122. Deposit of sculptures.
- 52 + 53 - 60 b.
Head and part of shoulders belonging to a life-size statue of terracotta; oval face; prominent, heavy chin; fatty cheeks; smiling mouth; long nose; bulging forehead; almond-shaped eyes with marked eyebrows; plain front-hair of which a curl hangs vertically before the ears; ears covered by large spiral earrings; diadem around head decorated with circular pellets (of which five are restored); two plaits of hair falling down on shoulders on either side; necklace around neck with circular pendant. Traces of red on diadem, and of black on hair. Red clay, rather dark. Total height 39.5. Head height 19.3. Length 16.7. Width 14.0. Room 122. Deposit of sculptures.
53. Fragment of terracotta, belonging to No. 52. Room 122. Deposit of sculptures.
54. a) Fragment of a thin bronze rod with square section, pierced by small, bent bronze wires with pointed ends. Broken at both ends. Length 6.1.
b) Small fragments of bronze sheet with embossed representation of a lotus bud. Length 2.0. Room 122. Deposit of sculptures.
55. R. hand of life-size statue of terracotta with outstretched fingers; bracelets around wrist consisting of three stripes of clay. Thumb, top on ring finger, and part of bracelet missing; reconstructed from many fragments. Dark-red clay. Length 22.5. Room 122. Deposit of sculptures.
56. L. hand holding a fruit, belonging to a life-size statue. The fingers bear two rings each, except the thumb and the little finger which have only one; the fruit is held by the thumb, the index, and the middle finger. White limestone. Length 13.5. Room 122. Deposit of sculptures.
57. Fragments of a statuette, similar to No. 491. Head, feet, and tympanon missing. White limestone. Height 10.2. Room 122. Deposit of sculptures.
58. Small bowl of limestone with melon-ribs, belonging to a statue. Diam. 11.0. Room 122. Deposit of sculptures.
59. Short bronze nail with large, disc-shaped head. Length 2.5. Room 122. Deposit of sculptures.
60. a) Fragment of terracotta representing a bird sitting on a hand; the bird has a pointed beak; belonging to a statuette. Length 4.5.
b) Fragments of neck and shoulder, belonging to No. 52. Room 122. Deposit of sculptures.
61. Female statuette with l. leg slightly advanced; r. arm bent over breast, its hand holding object (fruit?) between the prominent breasts; l. arm slightly bent and advanced, partly free from body, its hand grasping

- some folds of himation; bracelet around l. wrist; sloping shoulders; oval head with slightly smiling lips; rounded chin and cheeks; nose in line with forehead; eyes of myrtle-leaf shape; curls over forehead rendered by oblique notches; large ears with rosette-shaped earrings; conical hair-dress and a band of rosettes around head above front curls; long hair at back of head; folded chiton with sleeves ending at elbows; folds rendered by shallow incisions; oblique himation over r. shoulder and falling in deep folds along r. side. Feet and small piece of lower part of statuette missing; broken at neck. White limestone. Height 36.5. Shoulder width 12.1. Breast to back 5.2. Waist width 6.0. Hips width 7.5. Head height 6.2. Length 4.8. Width 4.5. Room 122. Deposit of sculptures.
62. Group of statuettes representing Isis seated with the Harpocrates child on her knee and Osiris (?) standing behind. Isis sits on a high throne, which is provided with horizontal supports between the legs; her feet rest on a footstool, the legs of which are shaped as bent goats' legs. She is dressed in a long, vertically folded chiton and an obliquely folded himation, wrapped around waist and falling across body from l. shoulder. Her arms support the child, who sits on her r. knee, facing to the right; the r. hand of Isis holds the knee of the child, the l. is placed on the child's back. Harpocrates wears a short, plain chiton; some fruits are placed on a piece of folded cloth over his knees; behind the child, parts of the broken wings are visible, making the identification certain. Behind the throne parts of a third person are visible, possibly Osiris. He stands close to the throne; his r. arm uplifted behind the head of Isis and his l. arm stretched across the upper arm of Isis and touching the r. side of the child. White limestone. Height 21.0. Room 122. Deposit of sculptures.
63. Female head with oval face; strong chin and cheeks; smiling mouth; nose in line with forehead; eyes of myrtle-leaf shape; curled hair over forehead parted in the middle, curls rather worn; bonnet-shaped hair-dress; the hair is wrapped up in cloth and bands wound twice or thrice around the head; earrings with rosettes. Traces of red colour on hair-dress; hair, eyelids, iris painted black. R. side of face much worn. White, very soft limestone. Total height 6.0. Head height 5.0. Length 4.3; (with hair-dress) 5.8. Width 3.3. Room 122. Deposit of sculptures.
64. Fragment of female terracotta statuette, as No. 359. Worn and much damaged. Height 11.5. Room 122. Deposit of sculptures.
65. Head of terracotta, as No. 485. Height 4.0. Room 122. Deposit of sculptures.
66. Terracotta statuette, as No. 493. Head, neck, and parts of back missing; upper part worn and broken. Height 17.0. Room 122. Deposit of sculptures.
67. Torso of female statuette of terracotta; tubular body with oval section; isolinear feet protruding from body; necklace of beads with pear-shaped pendant; ends of two plaits, one on either side, falling down over breast. Traces of black ladder-pattern along either side of body. Neck, head, and arms missing. Provided with back-hole. Lower part wheel-made; upper part hand-made. Light-red clay. Height 26.0. Room 122. Deposit of sculptures.
68. R. foot of terracotta, belonging to a life-size statue; the foot seems to wear shoe. Red clay. Length 22.0. Room 122. Deposit of sculptures.
69. Fragment of lower part of a life-size terracotta statue, oval in section; isolinear feet wearing shoes. Room 122. Deposit of sculptures.
70. Fragment, as No. 69. Room 122. Deposit of sculptures.
71. Lower part of terracotta statuette, oval in section; a roughly oval excision in front where the separately made feet protrude; feet wearing shoes with pointed, upturned ends; above the feet the innermost garment is visible which might be a folded chiton with wavy outline; the outermost falls like an apron with oblique folds across body with wavy, raised borders. Black border on chiton; traces of black and red colour on feet and on the outermost garment. Height 42.0. Room 122. Deposit of sculptures.
72. Plank-shaped statuette representing standing man with isolinear feet on small base; vertical arms along sides of body; clinched hands; plain chiton with sleeves to elbows; plain himation over l. shoulder; borders of chiton and himation painted bright-red; dark dots on sleeves; dotted crosses scattered over himation. Neck and head missing. White limestone. Height 24.6. Room 122. Deposit of sculptures.
73. R. hand holding pomegranate; long fingers; bracelet around wrist. White limestone. Length 8.8. Room 122. Deposit of sculptures.
74. See No. 42. Room 122. Deposit of sculptures.
75. Base with feet and part of the drapery up to ankles preserved; l. foot advanced. White, soft limestone. Height 14.0. Room 122. Deposit of sculptures.
76. Fragments of base with feet, much worn. White, very soft limestone. Room 122. Deposit of sculptures.
- 77 + 78. Torso of female statuette; l. leg advanced; r. arm was bent across body; l. arm advanced having held flap of garment; rounded, rather hemispherical breasts; long chiton with sleeves ending at elbows; vertical, grooved folds above waist and along l. side; almost horizontal, slightly curved folds below waist across legs; the latter folds are carefully sculptured with rounded ridges between the grooves; Ionian, oblique mantle over r. shoulder; carefully sculptured groups of vertical folds. Head, most of r. arm, l. forearm, part of himation at l. side, and feet missing. White limestone. Height 44.5. Shoulder width 13.2. Breast to back 7.3. Waist width 7.5. Hips width 8.7.
79. Plain White VI pear-shaped bottle with narrow, concave neck; ring shaped rim; handle from rim to shoulder. Broken; parts missing. Height 10.0. Room 122. Deposit of sculptures.

80. Closed hand with a hole bored through for insertion of some object, marked nail on thumb. White limestone. Length 10.5. Room 122. Deposit of sculptures.
81. Fragments of a seated female statuette of terracotta. Room 122. Deposit of sculptures.
82. Female head with oval face; prominent chin; slightly smiling lips; nose in line with forehead; long eyes of myrtle-leaf shape; plain rosettes in the ears; hair over forehead parted in the middle, the curls rendered by parallel notches in slightly curved rows; on crown of head the hair is rendered by parallel grooves and tied into a knot at the back of head; two bands around head and two around the knot of hair at back; necklace with pendant around neck; on bands in hair traces of red; traces of black colour on hair in front; red lips and necklace; rosettes in ears black and red. Below r. ear small piece is split out; narrow hole in forehead; slightly worn surface. White limestone. Total height 8.0 Head height 6.8. Length c 5.5; (with hair-dress) 7.0. Width 4.1. Room 122. Deposit of sculptures.
83. Fragment of female statuette, similar to No. 77+78. Only the middle part of body with l. hand preserved. White limestone. Height 29.0. Room 122. Deposit of sculptures.
84. Fragment of female statuette; only lower part of statuette up to knees preserved, except fore-part of feet and base. White, soft limestone; surface obliterated. Height 14.0. Room 122. Deposit of sculptures.
85. Male head with oval, rather broad face; rounded chin and cheeks; slightly smiling mouth; nose in line with forehead; eyes of myrtle-leaf shape; wreath around head; curls of hair over forehead rendered by parallel notches; hair on top of head rendered by parallel, incised lines; plain, short hair at back of head; plain, disc-shaped ears. Traces of black on hair; green on wreath; a red border is visible below neck. White limestone. Total height 7.0. Head height 6.0. Length 5.5. Width 5.0. Room 122. Deposit of sculptures.
86. Fragment of female statuette, dressed in chiton and oblique mantle with carefully worked, vertical folds; l. hand grasping flap of chiton. Only middle part of statuette preserved. Border of mantle painted red; dotted crosses in red on mantle. White limestone. Height 22.8. Room 122. Deposit of sculptures.
87. Rectangular, moulded marble base of a sculpture. Length 58.0. Room 122. Deposit of sculptures.
88. Upper part of terracotta statuette representing female devotee with flat, solid body; both arms in pose of adoration, undigitated hands; ovoid head; slightly smiling mouth; rather broad nose; eyes of myrtle-leaf shape; painted eyebrows and lids; row of small curls over forehead; plain, disc-shaped ears; one short and one longer plait falling down over breast at either side, bracelet around r. wrist. Hair, eyebrows, lids, and iris painted black; traces of white colour in l. eye. Reddish-brown clay. Height 10.5. Room 122. Deposit of sculptures.
89. Fragment of back of head with a thick, torus-like wreath around head; plaited hair, the ends of which are tied together by strings and attached to back of head. White limestone. Room 122. Deposit of sculptures.
90. Fragments of statuette; one of them consists of a square base with isolinear feet and part of folded chiton; the other consists of a piece of body with surface covered by zigzag notches indicating the woollen himation. The fragments do not fit together. White limestone. Height of base 4.6. Height of body 5.7. Room 122. Deposit of sculptures.
91. Bronze coin. *Obverse*: entirely corroded. *Reverse*: eagle looking l.; standing on thunderbolt; wings open. Much worn. Diam. 1.8. Weight 3.85. Room 122. In the earth.
92. Head, belonging to No. 18. Room 122. Deposit of sculptures.
93. Fragment of statuette; only part from waist to about the ankles preserved. Remains of the lower part of himation which was open at l. side; the wool indicated by zigzag notches. White limestone. Height 12.0. Room 122. Deposit of sculptures.
94. Fragments of feet with base and lower part of statuette with remains of drapery. Black and red borders on dress still visible. White limestone. Height 15.7. Room 122. Deposit of sculptures.
95. R. foot of terracotta with pointed shoe; part of base preserved. Light-red clay. Length 17.0. Room 122. Deposit of sculptures.
96. a) Fragment of female statuette; only the part between breast and waist preserved with traces of r. forearm; some drapery folds visible at l. side. White limestone. Length 24.0.
b) Hand with bent fingers holding an upright aryballos with two knob-handles; upper part of aryballos missing. Marked finger nails. White limestone. Height 9.0. Room 122. Deposit of sculptures.
97. Fragment of female statuette; only lower part of statuette preserved with folds of chiton and himation visible. Red borders on chiton. White, very soft limestone; partly blackened by fire. Height 18.5. Room 122. Deposit of sculptures.
98. Statuette of terracotta, as No. 485, but with straight base. Worn; slightly reddish clay. Height 18.0. Room 122. Deposit of sculptures.
99. Female head, similar to No. 486, but with prominent nose and more vigorously sculptured face. Traces of red on hair-dress and lips; iris black. White, very soft limestone; blackened by fire. Height 4.8. Room 122. Deposit of sculptures.
100. Moulded statuette of terracotta representing a woman riding on a mule's back. The mule trots to the r. with l. foreleg uplifted and advanced; the woman sits in a saddle with high saddle bow, on which the hands rest; the legs hang straight down; oval head with bonnet-shaped head-dress; mantle with folds down to feet. Height 10.5. Room 122. Deposit of sculptures.

101. Fragments of a rectangular mounting of thin bronze leaf with one short side ending in a narrow, rounded excrescence with concave sides, pierced by a hole; two rivets at the opposite end. Length c. 13.0. Room 122. Deposit of sculptures.
102. Fragments of a statuette, with isolinear feet on square base. Much worn. White, very soft limestone. Height 5.3. Room 122. Deposit of sculptures.
103. Twenty-three bronze nails with flattened button heads; some of them bent. The bronze nails Nos. 104 and 131 are included. Length 17.5—12.0. Room 122. Deposit of sculptures.
104. See No. 103.
105. Fragment of a female statuette, as No. 495. Only lower part of statuette preserved. White limestone. Height 16.0. Room 122. Deposit of sculptures.
106. Base and feet of statuette. Small part of dress visible at r. side. White limestone. Height 3.5. Room 122. Deposit of sculptures.
107. Pomegranate of terracotta covered with a black slip; probably a votive gift belonging to a terracotta sculpture. Length 6.3. Room 122. Deposit of sculptures.
108. Head of terracotta, as that of No. 485. Light-buff clay and slip. Height 4.5. Room 122. Deposit of sculptures.
109. Base with fragments of feet. On base, a small human head in relief *en creux*; possibly the signature of the sculptor. White limestone. Size: 70.0×55.0. Left *in situ*. Room 122. Deposit of sculptures.
110. Base with feet. White limestone. Size: 85.0×47.0. Left *in situ*. Room 122. Deposit of sculptures.
111. Coarse, wide, open bowl with flat base; rounded sides; flat rim. Diam. 18.5. Room 123. Floor.
112. Plain White VI depressed jug with flat base; marked shoulder line; neck slightly tapering upwards; widening mouth; handle from rim to shoulder; spout on shoulder opposite the handle. Height 18.3. Room 123. Floor.
113. Plain White VII jug with flat, raised base; oval body; short neck; erect rim; handle from neck to shoulder. Height 15.7. Room 123. Floor.
114. Fragments of statuette of limestone. Much worn. Room 122. Deposit of sculptures.
115. Plain White VII sack-shaped jug with flat base; concave neck; flaring rim; handle from rim to shoulder. Parts of neck and rim missing. Height 12.5. Room 118. Floor.
116. Female head of terracotta with flat back; broad face with rounded, broad chin; large, clumsy nose; slightly smiling mouth; eyes of myrtle-leaf shape, rather worn; hair over forehead with incised notchings; plain diadem or veil covering the hair. Reddish clay. Height 4.3. Room 92. Floor.
117. Small terracotta fragment of the hind quarters of an animal. Length 4.8. Room 92. Floor.
118. Female statuette of terracotta with tubular body narrowing downwards; protruding, isolinear feet; r. arm bent



- and lifted in pose of adoration; the l. arm bent over breast; bracelet around l. wrist and traces of another around the r.; oval head with rounded chin; slightly smiling mouth; prominent nose; painted eyes and iris; hair over forehead rendered by vertical grooves; two spirally twisted plaits at either side fall over shoulders and upper arms. Put together from many pieces; part of nose, neck, and plaits are restored in plaster. Lower part wheel-made. Back-hole. Red clay. Height 43.0. Room 116. In the earth on rock.
- 119—259. Torso of female statuette, similar to No. 61. Head, neck, part of l. shoulder, r. hand with object missing; much worn. (Lower part=No 259). White limestone. Height 44.0. Room 116. In the earth on rock.
120. Head with long, oval face; heavy chin; rounded cheeks; smiling mouth; eyes of myrtle-leaf shape; notched, curled hair over forehead; plain diadem around head; hair on top of head rendered by radiating grooves; long hair falling down at back of head and along sides of neck leaving the ears visible. Mouth and chin chipped; worn. White limestone. Height 5.0. Length 4.9. Width 3.3. Room 116. In the earth on rock.
121. Head of terracotta, as No. 485. Height 4.5. Room 116. In the earth on rock.
122. Female statuette, belonging to No. 124. Room 116. In the earth on rock.
123. a) Fragment of terracotta statuette in "snow-man" technique; cylindrical body; almost cylindrical head with large nose; long beard; holding a double flute with both hands in his mouth; disc-shaped ears. Only upper part from waist preserved. Height 9.0.
b) Fragments of a statuette of terracotta in "snow-man" technique, representing a dancing woman with outstretched arms; head covered by a veil hanging down back and over shoulders; wearing chiton. R. hand is attached to another hand belonging to a now missing statuette. Only upper part preserved. Coarse, bright-red clay. Height 9.0.
c) Fragments of three statuettes, as No. 123 b. Room 116. In the earth on rock.
- 124—122. Fragments of ring-dancers in "snow-man" technique, consisting of four female figures (one missing); attached to circular base; flattened bodies; outstretched arms; face details worn; wearing long veils on heads falling over shoulders and bodies. One stands in the middle; the other in the periphery. Ends of arms missing. Red clay. Diam. of base 16.0. Height of tallest statuette 13.0. Room 116. In the earth on rock.
125. Plain White VI pear-shaped bottle, similar to No. 79. Incomplete. Room 116. In the earth on rock.
126. Fragment of head and neck of terracotta; only lower part of head preserved. Traces of plait visible at r. side of neck. Height 10.3. Room 116. In the earth on rock.
127. Fragment of a shallow, rounded bronze bowl with flat-

- tened rim; mended at rim in ancient times by means of a bronze plate fixed by bronze nails. Diam. 24.0. Room 116. In the earth on rock.
128. Fragments of moulded statuette of terracotta holding lyre with l. hand; the r. hand plays the strings; folded dress. Face completely damaged; part of lyre missing. Height c. 10.5. Room 116. In the earth on rock.
129. Fragment of moulded, female terracotta statuette with flat back; r. hand bent over breast; l. arm along side of body; oval face with details worn away; bonnet-shaped hair-dress with elongated top; hair over forehead separated from the hair-dress by two incised lines; a plait hanging down on either side of neck over shoulders. Traces of red and black colour visible. Buff clay. Much worn. Height 9.2. Room 116. In the earth on rock.
130. Fragment of terracotta horse in "snow-man" technique. Remains of a saddle indicate that the fragments belong to a rider statuette. Nose and legs missing. Reddish clay. Length 7.5. Stray find.
131. See No. 103. Room 123. Floor.
132. Plain White VI oval jar with base-disc; erect, concave, ring-shaped rim; two horizontal handles on shoulder. Pieces of upper part of jar missing. Height 26.7. Room 123. Floor.
133. a) Open, saucer-shaped lamp of terracotta with flat base; pinched wick-holder, flat rim. Pieces of rim missing. Length 10.2.
b) Small, open, saucer-shaped lamp of terracotta with flat base; pinched wick-holder (end missing); plain rim. Length 6.5.
c) Ladle-shaped lamp of coarse ware with flattened base; plain rim; two pinched wick-holders with attached, horizontal handle. Length 18.0.
d) Plain White VI small, shallow bowl with flat, raised base; curved sides; plain rim. Diam. 6.6. Room 123. Floor.
134. Plain White VI shallow bowl with flattened base; rounded sides; plain rim. Diam. 12.0. Room 123. Floor.
135. Plain White VII bowl with flat base; funnel-shaped body; plain rim. Diam. 11.7. Room 123. Floor.
136. White Painted VI ovoid amphora with base-ring; slightly concave neck; flattened, out-turned rim; horizontal handles on shoulder. Encircling bands and lines around neck and body; frieze of leaf-ornaments below neck on shoulder; wavy line on shoulder between handles. Height 43.0. Room 123. Floor.
137. Plain White VII jug with base-disc; depressed body; rather narrow, concave neck; down-turned rim; handle from rim to shoulder. Height 14.5. Room 123. Floor.
138. Ring-shaped, moulded stand of bronze with concave sides. Diam. 8.3. Room 123. Floor.
139. Stand of bronze, as No. 138. Diam. 8.3. Room 123. Floor.
140. Stand of bronze, shape as No. 138. Diam. 7.8. Room 123. Floor.
141. Black Glazed lekythos with conical body; base-disc; sharply defined, horizontal shoulder; narrow, slightly concave neck; short funnel-mouth; handle from neck to shoulder. Black glazed body, handle, and mouth; dotted line around base of neck; radiating leaf-ornaments around shoulder. Height 9.5. Room 123. Floor.
142. Coarse shallow bowl with rounded outline; flat base; plain rim. Broken. Diam. 12.0. Room 123. Floor.
143. Statuette of terracotta, as No. 49, but r. leg advanced, with bent knee and low base without mouldings. Neck and head missing. Height 17.0. Room 123. Floor.
144. a) Fragment of moulded, female head of terracotta; oval face; nose in line with forehead; eyes of myrtle-leaf shape; plain hair parted in the middle; plain diadem. Only left side of head preserved; chin and mouth missing. Buff clay. Height 4.2.
b) Moulded, female head of terracotta with bonnet-shaped hair-dress; thick mass of hair over forehead. Details of face worn away. Brown, reddish clay. Height 3.8. Room 123. Floor.
145. Coarse bowl, as No. 142. Diam. 11.5. Room 137. In the earth.
146. Fragment of upper part of moulded, female statuette of terracotta with sloping shoulders; oval head with nose in a line with forehead; plain mass of hair over forehead parted in the middle; plain diadem and bonnet-shaped hair-dress. Part of r. shoulder missing; broken off at breast; back-hole. Greyish clay. Height 8.5. Room 137. In the earth.
147. Fragment of a terracotta mould for casting a terracotta statuette of female figure with rounded face; curled hair falling along the sides; r. arm bent across breast inside himation; only upper part of mould preserved. Length 7.0. Room 137. In the earth.
148. Fragment of a male statuette of terracotta in "snow-man" technique; oval head; rounded beard; pellet mouth placed just below the large pellet nose; large, bulging eyes; band around head; small pellet ears; a hair-plait hanging along either side of neck. R. arm was bent over the breast. Lower part of body missing. Bright-red clay. Height 7.6. Room 137. In the earth.
- 149—225.
See Temple of Athena.
- 226 a) Black Glazed bowl with moulded base-ring; rounded side; ridged line below rim inside; plain rim; two horizontal handles. Four impressed palmettes in the bottom surrounded by encircling band of leaf-ornament. Graffito on base (see Appendix IV). One handle and parts of bowl missing. Diam. 12.4.
b) Lumps and fragments of bronze. Room 45. Floor.
- 227—244.
See Temple of Athena.
245. Square slab of limestone, with a circular projection; used as a cover to a large jar, the projection having been inserted in the mouth. Length 22.0. Room 49. Floor.
246. Fragment of a Plain White VI pithos, as No. 266. Room 10. Floor.

247. Incense-burner of limestone, consisting of a rounded, shallow bowl with ring-shaped moulding below, standing on a wide, conical foot. Part of bowl missing. Height 9.5. Room 10. Floor.
248. Fragment of a Plain White VI pithos, as No. 266. Room 12. Floor.
249. Lower part of a Plain White VI pithos, as No. 266. Room 12. Floor.
250. Piece of stucco, painted red. Room 11. Floor.
251. Statuette of Zeus Ammon sitting in a plain armchair with high back; both arms rest on the arms of the chair; bulging breast; very short neck; ram's horns on head; wearing a plain garment which covers the feet; details not preserved; much worn. White, very soft limestone. Height 11.5. Room 11. Floor.
252. Statuette, as No. 251; the hands rest on the knees; chiton with marked border above the feet; a flap of himation visible at r. shoulder. Head, l. forearm, r. hand, part of feet missing; surface much worn. White, very soft limestone. Height 6.5. Stray find.
253. Moulded, female terracotta head with oval face; sharply defined, broad chin; smiling mouth; long nose in line with forehead; eyes of myrtle-leaf shape; hair over forehead in rather worn curls; plain diadem around head and bonnet-shaped hair-dress; hair falling down at either side of neck. Red clay. Height 4.0. Stray find.
- 254—255.
See Temple of Athena.
256. Torso of nude, male statuette with r. leg advanced; r. arm raised; l. arm along side of body; muscles of belly clearly defined and circumscribed. Head, neck, both arms, and legs missing; front part much damaged; a large piece missing between shoulders at back. Grey, hard limestone. Height 73.0. Found on the slope N. W. of the palace.
257. a) Fragment of r. knee and calf of a male statuette. White limestone. Height 8.4.
b) Fragment of l. leg of a male statuette. White limestone. Height 7.5.
c) Fragment of torso of male statuette with hanging folds at l. thigh; girdle around waist; only part between knees and waist preserved. Surface much worn. White, soft limestone. Height 10.0.
d) L. hand holding some folds of drapery. White limestone. Length 7.0. Found on the slope N. W. of the palace.
258. R. hand of terracotta with part of forearm; the hand was held against the dress. Bright-red, polished clay. Length 4.8. Room 82. Below floor.
259. Lower part of statuette, belonging to No. 119. Stray find.
260. Bronze nails, as No. 131. Room 45. Floor.
261. Coarse jug with round base; squat body; almost cylindrical neck; plain rim; handle from rim to shoulder. Height 14.7. Room 45. Floor.
262. Male head with oval face; rounded chin and cheeks; smiling mouth; rather large eyes of myrtle-leaf shape; the hair is combed in radiating grooves ending over forehead in small bows; incised lines over hair forming a sort of latticed pattern and probably indicating a veil. White limestone; much worn. Height 4.0. Room 93. Floor.
- 263—264.
See Temple of Athena.
265. Fragment of a Plain White VI pithos, as No. 266. Room 92. Floor.
266. Plain White VI large, bobbin-shaped pithos with pointed base; rounded shoulder; no neck; erect, out-turned rim; two large, erect loop-handles on shoulder. Height 97.0. Room 92. Floor.
267. Plain White VI pithos, as No. 266. Height 101.0. Room 92. Floor.
268. Fragment of a Plain White VI pithos, as No. 266. Room 92. Floor.
269. Fragment of female, moulded terracotta statuette with flattened back; oval face; mouth and nose chipped; prominent eyes; hair parted in the middle; high hair-dress or diadem around head. Only upper part preserved; has evidently belonged to a vessel. Traces of red and black on hair-dress. Height 50. Room 88. Floor.
270. Scaraboid of steatite, pierced by a hole lengthwise. Plain. Length 1.8. Room 88. Floor.
271. Flat disc of limestone, pierced by a central hole; probably used as a net-sinker. Diam. 3.7. Room 88. Floor.
272. Silver button with flat base; convex upper side with two knob-shaped projections; bordered by circular ring with transverse incisions. Diam. 2.4. Room 82. Floor.
273. Bronze pin with plain head; bent. Length 8.0. Room 82. Floor.
274. Fragment of a bronze nail. Length 5.5. Room 41. Floor.
275. Lump of bronze. Length 4.2. Room 85. Floor.
276. Socket-shaped mounting with moulded base and concave sides. Below base remains of lead used for fixing the mounting. Length 4.0. Room 39. Below floor.
277. Four-sided arrow-head of bronze, tapering towards the end; double-curved outline; straight tang. Length 9.0. Room 39. Below floor.
278. Four-sided arrow-head of bronze; slightly double-curved outline; pointed end; straight tang. Length 9.7. Room 39. Below floor.
279. Moulded statuette of terracotta representing a tortoise; four peg-shaped legs. Buff clay. Height 3.8. Room 46. Floor.
280. Fragment of an iron rod with angularly bent end. Length 10.6. Room 54. Floor.
281. Fragments of rectangular bronze strip; framed by parallel, ridged lines and holes for fixing. Other fragments with impressed ornaments of kymation and guilloche ornaments. Room 54. Floor.
282. Spear-head of bronze, four-sided; tapering towards the pointed end; tubular shaft; moulded ring on pike and shaft; relief ridges encircling the shaft. Length 16.0. Room 51. Floor.

283. Bronze arrow-head, as No. 420. Length 4.3. Room 38. Floor.
284. Fragment of a bronze nail with flat, disc-shaped head. Length 3.6. Room 38. Floor.
285. Coarse bowl with base-disc; rounded outline; plain rim; part missing. Diam. 11.8. Room 38. Floor.
286. Short, cylindrical spindle-whorl of terracotta; pierced by a central hole. Diam. 4.5. Room 47. Floor.
287. Depressed rounded loom-weight of basalt, with a hole bored lengthwise. Diam. 8.7. Room 47. Floor.
288. Fragments of a bronze leaf, probably rectangular in shape; decorated with a border of kymation ornament along the edge and a frieze of volutes and palmettes in *repoussé*. Length 7.0.; 4.0; 4.5. Room 38. Floor.
289. Stele of limestone, consisting of a papyrus-shaped lower part and a violin-shaped upper part. A rectangular groove on top for insertion of a wooden beam. On either side of the violin-shaped part, a female head in relief; unfinished. Height 175.0. Room 47. Floor.
290. Capital of hard, white limestone which probably crowned one of the columns of the central court of the palace. The shape of the capital is a Cypriote variety of the Egyptian Hathor capital; a female head in relief occupies the centre of each long side; oval face with faintly smiling mouth; full cheeks; almost vertical nose; elliptical eyes with lids; hair over forehead parted in the middle and combed in wavy curls over the temples; ears have rosettes with central dot and are sculptured facing the spectator; head crowned by an arch-shaped diadem running from ear to ear; above diadem, remains of conventionalized Hathor curls with three radiating, moulded bands; lower part of curls missing. Above head, a small edifice in Egyptian style with moulded sides and top; an open gate on the façade and an *uraeus* in the centre. Height 100.7. Greatest width 79.5. Width at top 42.3. Chin to top of forehead 40.0. Width at temples 26.5. Width from ear to ear 44.2. Length of eyes 8.1. Length of mouth 9.3. Length of nose 11.5. Room 47. Floor.
291. Fragment of carved limestone wing, probably forming part of a winged sun-disc ornament. Remains of green and red paint on wing. Length 17.0. Room 47. Floor.
292. a) Coarse globular, depressed jar; rounded base; upright, raised rim; two vertical, moulded handles on body. Incomplete. Height 17.5. Room 59. Floor.
 b) Silver bowl with rounded base; erect, splayed rim. Diam. 14.2. Weight 195.0. Inside No. 292 a.
 c) Hemispherical, rounded bowl with round base; erect, concave rim; body of bowl decorated with rosette ornaments in relief; border of kymation ornaments encircling base of rim. Diam. 9.6. Weight 215.0. As No. 292 b.
 d) Silver bowl with moulded base-ring; double-curved outline; plain rim; two horizontal handles below rim. Diam. 12.0. Between handles 15.3. Weight 191.0. As no. 292 b.
 e) Bracelet of solid gold bar, circular in section; roughly oval in shape, in bent opposite the ends which are in shape of goats' heads. The heads are delicately sculptured with horns curved backwards and incised with encircling grooves; long, thin ears, turned back; globular eyes with incised lids; carefully modelled muzzle and nostrils; fold of skin at the corner of the mouth indicated by narrow elevations and hair on cheeks by curved band with transverse incisions. Diam. 9.8. Weight 221.0. As No. 292 b.
 f) Bracelet of gold, as No. 292 e, but more carefully worked. The encircling grooves around the horns are narrower and closer and the incisions on the cheek-hair end with spiral curls. Diam. 10.2. Weight 243.0. As No. 292 b.
 g) Pair of gold bracelets, shape as preceding, but ending in calves' heads. These are vigorously sculptured, short and broad, with large ears, turned back; globular eyes with modelled lids; carefully modelled muzzle and nostrils; fold of skin at corner of the mouth indicated by narrow elevation, and hair on the cheeks by double rows of transverse incisions. Diam. 10.1; 10.2. Weights 238.0; 242.0. As No. 292 b.
 h) Pair of circular silver bracelets; the ends in shape of conventionalized snakes' heads with circular, incised eyes; scales indicated by incisions. Diam. 9.2; 8.8. Weights 49.0; 48.5. As No. 292 b.
 i) Silver bracelets, as preceding, but somewhat smaller. Diam. 8.0; 7.1. Weights 32.0; 31.0. As No. 292 b.
 j) Silver bracelets, similar to No. 292 i. Diam. 7.0. Weights 30.5; 30.0. As No. 292 b.
 k) Pair of circular silver bracelets; the ends decorated with incised lines. Diam. 4.9. Weights 24.5; 20.5. As No. 292 b.
 l) Pair of silver bracelets, similar to preceding. Diam. 5.1; 4.8. Weights 24.5; 22.0. As No. 292 b.
 m) Pair of silver bracelets, circular and flat; ends decorated with incised star ornament of radiating lines. Diam. 5.1. Weight 20.1. As No. 292 b.
 n) Pair of silver bracelets with spiral coils; round in section; plain. Diam. 8.8; 8.7. Weights 191.5; 187.5. As No. 292 b.
 o) Circular silver bracelet, hollow; in two parts, joined together by means of a rivet; overlapping ends decorated with snakes' heads, pierced by holes in which a narrow pin fixing the ends was inserted; snakes' eyes circular, incised; scales incised, more naturalistically than on Nos. 292 h ff. Diam. 9.0. Weight 56.0. As No. 292 b.
 p) Four lumps of gold. Length 2.15; 1.1; 1.3; 0.6.
 q) Cylinder pendant of silver; broken in three pieces. Length c 4.5.
 r) Pendant of silver in shape of a cicada, with a circular loop for suspension. Longitudinal grooves on wings and transverse grooves on back. Length 3.3.
 s) Persian darics.
 1. Gold daric. *Obverse*: the Great King advancing r. in "Knielauf" attitude; long, straight beard; wearing

- 17 Obverse: Left, $\cdot \cdot 8 \uparrow \neq$ Right, $\cdot \cdot \cdot \cdot \times \uparrow \cdot \cdot$ Reverse: Above, $\cdot \cdot \cdot \uparrow \neq$
Below, $\uparrow \cdot \cdot \cdot \cdot$
- 18 Obverse: Right, $\cdot \wedge * \cdot \cdot \times \uparrow \cdot \cdot \uparrow$ Reverse: Above, $\uparrow \cong 8 \uparrow \neq$ Below,
 $\uparrow \cdot \cdot \cdot \uparrow \cdot$
- 19 Obverse: Right, $\uparrow \wedge * \cdot \cdot \times \uparrow \cdot \cdot \uparrow$ Reverse: Above, $\uparrow \cdot 8 \uparrow \neq$ Below, $\uparrow \cdot \cdot \cdot \uparrow \cdot \cdot \uparrow$
- 20 Obverse: Right, $\uparrow \wedge * \cdot \cdot \times \uparrow \cdot \cdot$ Reverse: Above, $\cdot \cong 8 \uparrow \neq$ Below, $\uparrow \cdot \cdot \cdot \uparrow \cdot \cdot \uparrow$
- 21 Obverse: Left, $\cdot \cdot 8 \cdot \cdot$ Right, $\uparrow \wedge * \cdot \cdot \times \uparrow \cdot \cdot \uparrow$ Reverse: Above, $\uparrow \cong 8 \uparrow \neq$
Below, $\uparrow \cdot \cdot \cdot \uparrow \cdot \cdot \uparrow$
- 22 Obverse: Left, $\uparrow \cdot \cdot \cdot \cdot$ Right, $\cdot \wedge \cdot \cdot \cdot \cdot \uparrow \cdot \cdot \uparrow$ Reverse: Above, $\uparrow \cong 8 \uparrow \neq$
Below, $\uparrow \cdot \cdot \cdot \uparrow \cdot \cdot \uparrow$
- 23 Obverse: Right, $\cdot \cdot \cdot \uparrow \cdot \cdot \uparrow$ Reverse: Above, $\uparrow \cdot \cdot \uparrow \neq$ Below, $\cdot \cdot \cdot \uparrow \cdot \cdot \uparrow$
- 24 Obverse: Left, $\uparrow \cdot \cdot \cdot \cdot$ Right, $\cdot \cdot * \cdot \cdot \times \uparrow \cdot \cdot \uparrow$ Reverse: Above, $\uparrow \cong 8 \cdot \cdot$
Below, $\uparrow \cdot \cdot \cdot \uparrow \cdot \cdot \uparrow$
- 25 Obverse: Left, $\uparrow \cdot 8 \uparrow \neq$ Right, $\cdot \cdot \cdot \cdot \cdot \uparrow$ Reverse: Above, $\uparrow \cong 8 \uparrow \neq$ Below,
 $\cdot \cdot \cdot \uparrow \cdot \cdot \uparrow$
- 26 Obverse: Right, $\cdot \cdot \cdot \cdot \cdot \uparrow$ Reverse: Above, $\cdot \cong 8 \uparrow \neq$ Below, $\uparrow \cdot \cdot \cdot \uparrow \cdot \cdot \uparrow$
- 27 Obverse: Left, $\uparrow \cdot \cdot \cdot \cdot$ Right, $\uparrow \wedge * \cdot \cdot \times \uparrow \cdot \cdot \uparrow$ Reverse: Above, $\uparrow \cong 8 \uparrow \neq$
Below, $\uparrow \cdot \cdot \cdot \uparrow \cdot \cdot \uparrow$
- 28 Obverse: Left, $\uparrow \cdot 8 \uparrow \neq$ Right, $\cdot \wedge * \cdot \cdot \times \uparrow \cdot \cdot \uparrow$ Reverse: Above, $\uparrow \cong 8 \uparrow \neq$
Below, $\uparrow \cdot \cdot \cdot \uparrow \cdot \cdot \uparrow$
- 29 Obverse: Left, $\uparrow \cdot 8 \uparrow \neq$ Reverse: Above, $\uparrow \cong 8 \cdot \cdot$ Below, $\uparrow \cdot \cdot \cdot \uparrow \cdot \cdot \uparrow$

Fig. 144 Vouni. Inscriptions of Coins Nos. 292 t: 17—29.

30. Obverse: Right, 𐎠 𐎡 𐎢 𐎣 𐎤 𐎠 𐎡 𐎢 𐎣 𐎤 Reverse: Above, $\cdot \text{𐎠 𐎡 𐎢}$ Below, 𐎠 𐎡 𐎢 𐎣 𐎤
31. Reverse: Above, 𐎠 𐎡 𐎢 Below, 𐎠 𐎡 𐎢 𐎣 𐎤
32. Reverse: Above, $\cdot \text{𐎠 𐎡 𐎢}$ Below, 𐎠 𐎡 𐎢 𐎣 𐎤
33. Obverse: Left, 𐎠 𐎡 𐎢 Right, 𐎠 𐎡 𐎢 𐎣 𐎤 𐎠 𐎡 𐎢 𐎣 𐎤 Reverse: Above, $\cdot \cdot \cdot \text{𐎠 𐎡}$ Below, 𐎠 𐎡 𐎢 𐎣 𐎤
34. Obverse: Left, $\cdot \cdot \text{𐎠 𐎡 𐎢}$ Right, $\text{𐎠 𐎡 𐎢} \cdot \cdot \cdot \cdot \text{𐎠 𐎡 𐎢}$ Reverse: Above, 𐎠 𐎡 𐎢 Below, $\text{𐎠} \cdot \cdot \text{𐎠 𐎡}$
35. Obverse: Left, $\text{𐎠} \cdot \cdot \cdot \cdot$ Right, $\cdot \cdot \cdot \cdot \text{𐎠 𐎡 𐎢 𐎣 𐎤}$ Reverse: Above, 𐎠 𐎡 𐎢 Below, $\cdot \text{𐎠 𐎡 𐎢 𐎣 𐎤}$
36. Reverse: Above, $\cdot \text{𐎠 𐎡 𐎢}$ Below, 𐎠 𐎡 𐎢 𐎣 𐎤
37. Obverse: Right, 𐎠 𐎡 𐎢 𐎣 𐎤 𐎠 𐎡 𐎢 Reverse: Above, 𐎠 𐎡 𐎢 Below, 𐎠 𐎡 𐎢 𐎣 𐎤
38. Obverse: Below, $\cdot \text{𐎠 𐎡 𐎢}$ Reverse: Above, 𐎠 𐎡 𐎢 Below, 𐎠 𐎡 𐎢 𐎣 𐎤
39. Obverse: Below, 𐎠 𐎡 𐎢 Reverse: Above, 𐎠 𐎡 𐎢 Below, 𐎠 𐎡 𐎢 𐎣 𐎤
40. Obverse: Below, $\cdot \text{𐎠 𐎡 𐎢}$ Reverse: Above, 𐎠 𐎡 𐎢 Below, 𐎠 𐎡 𐎢 𐎣 𐎤
41. Reverse: Above, $\cdot \text{𐎠 𐎡 𐎢}$ Below, 𐎠 𐎡 𐎢 𐎣 𐎤
42. Obverse: Below, $\cdot \text{𐎠 𐎡 𐎢}$ Reverse: Above, 𐎠 𐎡 𐎢 Below, $\cdot \text{𐎠 𐎡 𐎢 𐎣 𐎤}$
43. Obverse: Below, $\cdot \cdot \text{𐎠 𐎡 𐎢}$ Reverse: Above, 𐎠 𐎡 𐎢 Below, $\cdot \text{𐎠 𐎡 𐎢 𐎣 𐎤}$

Fig. 145. Vouni. Inscriptions of Coins Nos. 292 t: 30—43.

44. Obverse: Below, $\cdot \uparrow \cdot \cdot$ Reverse: Above, $\uparrow \neq$ Below, $\uparrow \uparrow \searrow \uparrow \oplus \uparrow$
45. Obverse: Below, $\cdot \uparrow \uparrow \neq$ Reverse: Above, $\uparrow \neq$ Below, $\uparrow \uparrow \searrow \uparrow \oplus \cdot$
46. Obverse: Below, $\cdot \uparrow \uparrow \neq$ Reverse: Above, $\uparrow \neq$ Below, $\cdot \uparrow \searrow \uparrow \oplus \uparrow$
47. Obverse: Below, $\uparrow \uparrow \uparrow \neq$ Reverse: Above, $\uparrow \neq$ Below, $\uparrow \uparrow \searrow \uparrow \oplus \cdot$
48. Obverse: Below, $\cdot \cdot \uparrow \cdot$ Reverse: Above, $\uparrow \neq$ Below, $\uparrow \uparrow \searrow \uparrow \oplus \uparrow$
49. Obverse: Below, $\cdot \cdot \uparrow \neq$ Reverse: Above, $\uparrow \neq$ Below, $\cdot \uparrow \searrow \uparrow \oplus \uparrow$
50. Reverse: Above, $\cdot \cdot 8 \uparrow \cdot$ Below, $\cdot \cdot \cdot \cdot \oplus \cdot$
51. Obverse: Right, $\uparrow \vee \cdot \cdot \cdot \cdot$ Left, $\wedge \times \uparrow \uparrow$ Reverse: Above, $\cdot \cdot 8 \uparrow \neq$
Below, $\cdot \times \uparrow \uparrow \uparrow \vee$
52. Obverse: Right, $\cdot \cdot \cdot \cdot 8 \cdot \cdot$ Left, $\wedge \times \cdot \cdot$ Reverse: Above, $\cdot \uparrow 8 \uparrow \neq$
Below, $\cdot \times \uparrow \uparrow \uparrow \vee$
53. Obverse: Right, $\uparrow \vee \uparrow \uparrow 8 \uparrow \neq$ Left, $\wedge \times \cdot \cdot$ Reverse: Above, $\cdot \cdot 8 \cdot \cdot$
Below, $\cdot \times \uparrow \uparrow \uparrow \vee$
54. Obverse: Below, $\oplus \uparrow \cdot \cdot$
55. Obverse: Below, $\oplus \uparrow \cdot \cdot$ Reverse: Below, $\cdot \cdot \cdot \cdot \oplus \uparrow$
56. Obverse: Below, $\oplus \uparrow \uparrow \neq$ 57. Obverse: Below, $\cdot \uparrow \cdot \cdot$
58. Obverse: Below, $\cdot \uparrow \uparrow \cdot$ 59. Obverse: Below, $\oplus \uparrow \uparrow \neq$
60. Obverse: Left, $\uparrow 8 \uparrow \neq$ Right, $\uparrow \uparrow \searrow \uparrow \oplus \uparrow \uparrow$ Reverse: Above, $\uparrow \uparrow 8 \uparrow \neq$
Below, $\uparrow \uparrow \searrow \uparrow \oplus \uparrow$
61. Obverse: Left, $\uparrow 8 \uparrow \neq$ Right, $\cdot \cdot \searrow \uparrow \oplus \uparrow \uparrow$ Reverse: Above, $\uparrow \uparrow 8 \uparrow \neq$
Below, $\uparrow \uparrow \searrow \uparrow \oplus \uparrow$

Fig. 14^b. Vouni. Inscriptions of Coins Nos. 292 t: 44—49 (44—49), 57 (50), 59—69 (51—61).

62. Obverse: Left, $\uparrow 8 \uparrow \neq$ Reverse: Below, $\cdot \uparrow \searrow \uparrow \textcircled{0} \cdot$
63. Obverse: Left, $\uparrow 8 \uparrow \neq$ Right, $\uparrow \searrow \uparrow \textcircled{0} \uparrow \uparrow$ Reverse: Above, $\uparrow \uparrow 8 \uparrow \neq$
Below, $\uparrow \uparrow \searrow \uparrow \textcircled{0} \uparrow$
64. Obverse: Left, $\uparrow 8 \uparrow \neq$ Right, $\uparrow \uparrow \cdot \cdot \cdot \cdot \cdot$ Reverse: Above, $\uparrow \uparrow 8 \uparrow \neq$ Below,
 $\cdot \cdot \cdot \cdot \textcircled{0} \uparrow$
65. Obverse: Left, $\uparrow 8 \uparrow \neq$ Right, $\uparrow \cdot \searrow \uparrow \textcircled{0} \cdot \cdot$ Reverse: Above, $\uparrow \uparrow 8 \uparrow \neq$ Below,
 $\uparrow \uparrow \searrow \uparrow \textcircled{0} \uparrow$
66. Reverse: Above, $\uparrow \uparrow 8 \uparrow \neq$ Below, $\uparrow \uparrow \searrow \uparrow \textcircled{0} \cdot$
67. Obverse: Left, $\cdot \cdot \cdot \cdot \neq$ Right, $\uparrow \cdot \cdot \cdot \cdot \cdot$ Reverse: Above, $\cdot \uparrow 8 \uparrow \neq$ Below,
 $\cdot \uparrow \searrow \uparrow \textcircled{0} \uparrow$
68. Reverse: Above, $\uparrow \uparrow 8 \uparrow \neq$ Below, $\uparrow \uparrow \searrow \uparrow \textcircled{0} \uparrow$
69. Obverse: Left, $\uparrow 8 \uparrow \neq$ Right, $\uparrow \uparrow \searrow \uparrow \textcircled{0} \uparrow \uparrow$ Reverse: Above, $\uparrow \uparrow 8 \uparrow \neq$ Below,
 $\uparrow \uparrow \searrow \uparrow \textcircled{0} \uparrow$
70. Obverse: Left, $\uparrow 8 \uparrow \neq$ Right, $\cdot \cdot \searrow \uparrow \textcircled{0} \cdot \cdot$ Reverse: Above, $\uparrow \uparrow 8 \uparrow \neq$ Below,
 $\uparrow \uparrow \searrow \uparrow \textcircled{0} \uparrow$
71. Obverse: Left, $\uparrow 8 \uparrow \neq$ Right, $\uparrow \uparrow \searrow \uparrow \textcircled{0} \uparrow \uparrow$ Reverse: Above, $\uparrow \uparrow 8 \uparrow \neq$ Below,
 $\uparrow \uparrow \searrow \uparrow \textcircled{0} \uparrow$
72. Obverse: Left, $\cdot 8 \cdot \neq$ Right, $\uparrow \cdot \cdot \cdot \cdot \cdot$ Reverse: Above, $\cdot \uparrow 8 \uparrow \neq$ Below,
 $\uparrow \searrow \uparrow \textcircled{0} \uparrow$
73. Obverse: Left, $\cdot \cdot \cdot \neq$ Right, $\uparrow \uparrow \cdot \cdot \cdot \cdot \cdot$ Reverse: Above, $\uparrow \uparrow 8 \uparrow \neq$ Below,
 $\uparrow \uparrow \searrow \uparrow \cdot \cdot$
74. Obverse: Left, $\uparrow 8 \uparrow \neq$ Right, $\uparrow \uparrow \searrow \uparrow \textcircled{0} \uparrow \uparrow$ Reverse: Above, $\uparrow \uparrow 8 \uparrow \neq$ Below,
 $\uparrow \uparrow \cdot \uparrow \textcircled{0} \cdot$
75. Obverse: Below, $\uparrow \neq$ Reverse: Above, \neq Below, \uparrow
76. Obverse: Below, $\uparrow \neq$ Reverse: Above, $\uparrow \neq$
77. Reverse: Right, $\uparrow 8 \uparrow \neq$ Left, $\uparrow \uparrow \curvearrowright \curvearrowleft$
78. Reverse: Right, $\uparrow 8 \uparrow \neq$ Left, $\cong \triangleleft \curvearrowright \curvearrowleft$
79. Reverse: Left, $\curvearrowleft \neq$

Fig. 147. Vouni. Inscriptions of Coins Nos. 292 t: 70—82 (62—74), 87 (75), 127 (76); 292 v: 1—3, (77—79).

handys and *kidaris* with dentated top; face long and rather thin; straight nose; hair in thick, compact mass at back of head; bow in outstretched, l. hand; spear in r. hand over r. shoulder with point downwards. *Reverse*: oblong incuse with irregular ground. Diam. 1.5. Weight 8.21.

2. As No. s) 1. Diam. 1.6. Weight 8.19.

3. As No. s) 1, but face of the Great King coarse and thicker; the nose convex and prominent; the lips fatty; *kidaris* less high; hair flowing and beard curved with incised line of demarcation on cheek; rougher work. Diam. 1.6. Weight 8.20.

4. As No. s) 3. Diam. 1.5. Weight 8.25.

t) Coins from Marion.

1. Silver stater. *Obverse*: head of laureate Apollo with short hair, facing r.; border of linear and dotted circle. R., pa si le vo se | [sa]; l., [ta] si vo [i ko]. *Overstruck*. *Reverse*: goddess (Europa?) wearing long, girdled chiton, riding on bull, galloping to the r., in a hanging position along the bull and holding its r. horn with her r. hand; incuse square. Above, pa si le vo se; below, sa ta si vo i ko. Diam. 2.5. Weight 10.68. (Fig. 143, 1.)

2. As No. t) 1. *Obverse*: border of linear circle. R., [pa si] le vo se | sa; l., ta si vo i ko. *Not overstruck*. *Reverse*: as preceding. Diam. 2.5. Weight 10.72. (Fig. 143, 2.)

3. As No. t) 1. *Obverse*: r., [pa si le] vo se | sa; l., [ta] si vo i ko. *Overstruck*. *Reverse*: above, [pa] si [le vo se]; below, sa ta si vo i ko; much worn. Diam. 2.4. Weight 9.03. (Fig. 143, 3.)

4. As No. t) 1. *Obverse*: inscription worn. *Overstruck*. *Reverse*: inscription above, worn; below, sa [ta si] vo [i ko]. Diam. 2.2. Weight 10.29. (Fig. 143, 4.)

5. As No. t) 1. *Obverse*: inscription worn. *Overstruck*(?). *Reverse*: inscription above, worn; below, sa ta si vo [i ko]. Diam. 2.2. Weight 10.35. (Fig. 143, 5.)

6. As No. t) 1. *Obverse*: border of dotted circles; l., pa si le vo se; r., ti mo ka ri [vo se]. *Reverse*: above, pa si le o se; below, ti mo ka ri vo se. Diam. 2.4. Weight 10.43. (Fig. 143, 6.)

7. As No. t) 1. *Obverse*: l., [pa si] le [vo se]; r., ti mo ka ri vo se | ma ri e u se. *Reverse*: above, [pa] si le o se; below, ti mo [ka ri vo se]. Diam. 2.3. Weight 10.87. (Fig. 143, 7.)

8. As No. t) 1. *Obverse*: l., [pa si le] vo se; r., ti mo ka ri [vo se]. *Reverse*: above, pa si le o se; below, ti mo ka ri vo se. Diam. 2.4. Weight 10.79. (Fig. 143, 8.)

9. As No. t) 1. *Obverse*: border of linear and dotted circle; l., pa si le vo se; r. worn. *Reverse*: above, [pa] si le vo [se]; below, sa ta si vo i [ko]; l. part of incuse missing. Diam. 2.3. Weight 10.81. (Fig. 143, 9.)

10. As No. t) 1. *Obverse*: border of dotted circle. Inscription l. worn; r., ti mo ka ri vo se | ma [ri e] u [se]. *Overstruck*. *Reverse*: inscription worn. Diam. 2.4. Weight 10.44. (Fig. 143, 10.)

11. As No. t) 1. *Obverse*: inscription l. worn; r., ti mo ka [ri vo se]. *Reverse*: above, pa si le [o se]; below,

ti mo ka ri vo se. Diam. 2.2. Weight 10.71. (Fig. 143, 11.)
12. As No. t) 1. *Obverse*: l., [pa si] le vo se; r., ti mo ka ri [vo se ma ri e] u se. *Overstruck*. *Reverse*: above, pa [si le o] se; below, ti mo ka ri vo se. Diam. 2.9. Weight 10.56. (Fig. 143, 12.)

13. As No. t) 1. *Obverse*: l., pa si le [vo se]; r., [ti] mo ka ri vo se | ma ri e u se. *Reverse*: above, pa si le o [se]; below, ti mo ka ri vo se. Diam. 2.2. Weight 10.68. (Fig. 143, 13.)

14. As No. t) 1. *Obverse*: l., [pa si] le [vo se]; r., [ti mo ka ri vo se ma ri e] u se. *Reverse*: above, [pa] si le o [se]; below, ti mo ka ri vo se (worn). Diam. 2.4. Weight 10.72. (Fig. 143, 14.)

15. As No. t) 1. *Obverse*: l., pa si le vo se; r., ti mo [ka ri vo se]. *Reverse*: above, pa si le o se; below, ti mo ka [ri vo se]. Diam. 2.3. Weight 10.55. (Fig. 143, 15.)

16. As No. t) 1. *Obverse*: l., pa si le vo se; r., ti [mo ka ri vo se]. *Reverse*: above, pa si le o se; below, ti mo ka ri vo se. Diam. 2.2. Weight 10.56. (Fig. 143, 16.)

17. As No. t) 1. *Obverse*: l., pa si le [vo se]; r., [ti mo] ka ri vo se | ma [ri e u se]. *Reverse*: above, pa si [le o se]; below, [ti mo ka ri] vo se. Diam. 2.2. Weight 10.54. (Fig. 144, 17.)

18. As No. t) 1. *Obverse*: inscription l. worn; r., ti mo ka ri vo se ma ri e u [se]. *Overstruck*. *Reverse*: above, pa si le o se; below, [ti] mo ka ri vo se. Diam. 2.4. Weight 10.68. (Fig. 144, 18.)

19. As No. t) 1. *Obverse*: inscription l. worn and missing; r., ti mo ka ri vo se | ma ri e u se. *Overstruck*. *Reverse*: above, pa si le [o] se; below, ti mo ka ri vo se. Diam. 2.5. Weight 10.61. (Fig. 144, 19.)

20. As No. t) 1. *Obverse*: inscription l. worn; r., [ti mo] ka ri vo se | ma ri e u se. *Reverse*: above, pa si le o [se]; below, ti mo ka ri vo se. Diam. 2.2. Weight 10.79. (Fig. 144, 20.)

21. As No. t) 1. *Obverse*: l., [pa si] le [vo se]; r., ti mo ka ri vo se | ma ri e u se. *Reverse*: above, pa si le o se; below, ti mo ka ri vo se. Diam. 2.1. Weight 10.79. (Fig. 144, 21.)

22. As No. t) 1. *Obverse*: l., [pa si le] vo se; r., ti mo ka ri [vo se] | [ma ri e] u [se]. *Reverse*: above, pa si le o se; below, ti mo ka ri vo se. Diam. 2.6. Weight 10.78. (Fig. 144, 22.)

23. As No. t) 1. *Obverse*: inscription l. missing; r., ti mo ka [ri vo se]. *Reverse*: above, pa si [le o] se; below, ti mo ka [ri vo se]. Diam. 2.6. Weight 10.59. (Fig. 144, 23.)

24. As No. t) 1. *Obverse*: l., [pa si le vo] se; r., ti mo ka ri vo se | ma ri e [u se]. *Reverse*: above, [pa si] le o se; below, ti mo ka ri vo se. Diam. 2.2. Weight 10.59. (Fig. 144, 24.)

25. As No. t) 1. *Obverse*: l., pa si le vo se; r., ti mo [ka ri vo se]. *Reverse*: above, pa si le o se; below, ti mo ka ri [vo se]. Diam. 2.3. Weight 10.50. (Fig. 144, 25.)

26. As No. t) 1. *Obverse*: inscription l. worn; r., ti mo [ka ri vo se]. *Reverse*: above, pa si le o [se]; below, ti

- mo ri vo se. Diam. 2.2. Weight 10.53. (Fig. 144, 26.)
27. As No. t) 1. *Obverse*: l. [pa si le vo] se; r., [ti mo] ka ri vo se | ma ri e u se. *Reverse*: above, pa si le o se; below, ti mo ka ri vo se. Diam. 2.4. Weight 10.67. (Fig. 144, 27.)
28. As No. t) 1. *Obverse*: l., pa si le vo se; r., ti mo ka [ri vo] se | ma ri e u [se]. *Reverse*: above, pa si le o se; below, ti mo ka ri vo se. Diam. 2.3. Weight 10.67. (Fig. 144, 28.)
29. As No. t) 1. *Obverse*: l., pa si le vo se; r., missing. *Reverse*: above, [pa si] le o se; below, ti mo ka ri vo se. Diam. 2.4. Weight 10.65. (Fig. 144, 29.)
30. As No. t) 1. *Obverse*: inscription l. worn away; r., ti mo ka ri vo se | ma ri e u se. *Reverse*: above, pa si le o [se]; below, ti mo ka ri vo se. Diam. 2.2. Weight 10.65. (Fig. 145, 30.)
31. As No. t) 1. *Obverse*: inscription worn away. *Reverse*: above, [pa] si le o se; below, ti mo ka ri vo se. Diam. 2.1. Weight 10.73. (Fig. 145, 31.)
32. As No. t) 1. *Obverse*: inscription worn away. *Reverse*: above, pa si le o [se]; below, [ti] mo ka ri vo se. Diam. 2.3. Weight 10.20. (Fig. 145, 32.)
33. As No. t) 1. *Obverse*: l., [pa si] le vo se; r., ti mo ka ri vo se | ma ri e u se. *Reverse*: above, pa si [le o se]; below, ti mo ka ri vo se. Diam. 2.4. Weight 10.75. (Fig. 145, 33.)
34. As No. t) 1. *Obverse*: l., pa si le [vo se]; r., ti mo ka [ri vo se | ma ri] e u se. *Reverse*: above, [pa] si le o se; below, [ti] mo ka [ri vo] se. Diam. 2.4. Weight 10.76. (Fig. 145, 34.)
35. As No. t) 1. *Obverse*: l., [pa si le vo] se; r., ti mo ka ri vo se | ma [ri e u se]. *Reverse*: above, pa si le o se; below, ti mo ka ri vo [se]. Diam. 2.2. Weight 10.74. (Fig. 145, 35.)
36. As No. t) 1. *Obverse*: inscription worn away. *Reverse*: above, pa si le o [se]; below, ti mo ka ri vo se. Diam. 2.3. Weight 10.76. (Fig. 145, 36.)
37. As No. t) 1. *Obverse*: inscription l. missing; r., [ti mo ka] ri vo se | ma ri e u se. *Reverse*: above, [pa si] le o se; below, ti mo ka ri vo se. Diam. 2.3. Weight 10.80. (Fig. 145, 37.)
38. As No. t) 1. *Obverse*: circle worn; below, pa si | ti [mo]. *Reverse*: above, pa si; below, ti mo ka ri vo se. Diam. 2.4. Weight 10.58. (Fig. 145, 38.)
39. As No. t) 1. *Obverse*: below, pa si | ti mo. *Reverse*: above, pa si; below, ti mo ka ri vo se. Diam. 2.4. Weight 10.73. (Fig. 145, 39.)
40. As No. t) 1. *Obverse*: dotted circle; below, pa si | ti [mo]. *Reverse*: above, pa si; below, ti mo ka ri vo se. Diam. 2.5. Weight 10.76. (Fig. 145, 40.)
41. As No. t) 1. *Obverse*: inscription worn away. *Reverse*: above, pa [si]; below, ti mo ka ri vo se. Diam. 2.5. Weight 10.83. (Fig. 145, 41.)
42. As No. t) 1. *Obverse*: circle worn away; below, pa si | ti [mo]. *Reverse*: above, pa si; below, ti mo ka ri vo [se]. Diam. 2.4. Weight 10.67. (Fig. 145, 42.)
43. As No. t) 1. *Obverse*: below, pa si | [ti mo]. *Reverse*: above, pa si; below, ti mo ka ri vo [se]. Diam. 2.4. Weight 10.87. (Fig. 145, 43.)
44. As No. t) 1. *Obverse*: traces of circle; below, [pa si] | ti [mo]. *Reverse*: above, pa si; below, ti mo ka ri vo se. Diam. 2.4. Weight 10.61. (Fig. 146, 44.)
45. As No. t) 1. *Obverse*: below, pa si | ti [mo]. *Reverse*: above, pa si; below, [ti] mo ka ri vo se. Diam. 2.5. Weight 10.74. (Fig. 146, 45.)
46. As No. t) 1. *Obverse*: border worn; below, pa si | ti [mo]. *Reverse*: above, pa si; below, ti mo ka ri vo [se]. Diam. 2.3. Weight 10.62. (Fig. 146, 46.)
47. As No. t) 1. *Obverse*: below, pa si | ti mo. *Reverse*: above, pa si; below, [ti] mo ka ri vo se. Diam. 2.2. Weight 9.85. (Fig. 146, 47.)
48. As No. t) 1. *Obverse*: below, [pa si] | [ti mo]. *Reverse*: above, pa si; below, ti mo ka ri vo se. Diam. 2.2. Weight 10.89. (Fig. 146, 48.)
49. As No. t) 1. *Obverse*: dotted circle; below, pa si | [ti mo]. *Reverse*: above, pa si; below, ti mo ka ri vo [se]. Diam. 2.3. Weight 9.72. (Fig. 146, 49.)
50. As No. t) 1. *Obverse*: entirely worn. *Reverse*: entirely worn. Diam. 2.3. Weight 10.57.
51. As No. t) 50. Diam. 2.5. Weight 10.57.
52. As No. t) 50. Diam. 2.3. Weight 10.37.
53. As No. t) 50. Diam. 2.2. Weight 10.56.
54. As No. t) 50. Diam. 2.3. Weight 10.80.
55. As No. t) 50. Diam. 2.3. Weight 10.52.
56. As No. t) 50. Diam. 2.4. Weight 10.18.
57. As No. t) 1. *Obverse*: linear circle; inscription worn; Overstruck. *Reverse*: above, [pa] si le [o se]; below, [ti] mo [ka ri vo se]. Diam. 2.3. Weight 10.60. (Fig. 146, 50.)
58. As No. t) 50. Diam. 2.3. Weight 10.50.
59. Silver tetrobol, same representation as No. t) 1. *Obverse*: dotted and linear circle; r., [pa si le vo se] | sa ta; l., si vo i ko. *Reverse*: above, pa si le [vo se]; below, sa ta si vo i [ko]. Diam. 1.6. Weight 3.38. (Fig. 146, 51.)
60. As No. t) 59. *Obverse*: much worn; r., [pa si] le [vo se | sa ta]; l., [si vo] i ko. *Reverse*: above, pa si le vo [se]; below, sa ta si vo i [ko]. Diam. 1.6. Weight 3.13. (Fig. 146, 52.)
61. As No. t) 59. *Obverse*: r., pa si le vo se | sa ta; l., [si vo] i ko. *Reverse*: above, [pa si] le [vo se]; below, sa ta si vo i [ko]. Diam. 1.5. Weight 3.43. (Fig. 146, 53.)
62. As No. t) 59. *Obverse*: dotted circle; below, [pa si] | ti mo. *Reverse*: worn away. Diam. 1.7. Weight 3.40. (Fig. 146, 54.)
63. As No. t) 59. *Obverse*: border worn; below, [pa si] | ti mo. *Reverse*: above, worn away; below, ti mo [ka ri vo se]. Diam. 1.6. Weight 3.25. (Fig. 146, 55.)
64. As No. t) 59. *Obverse*: dotted circle; below, pa si | ti mo. *Reverse*: worn away. Diam. 1.7. Weight 3.24. (Fig. 146, 56.)
65. As No. t) 59. *Obverse*: worn; below [pa si] | ti [mo]. Overstruck. *Reverse*: worn away. Diam. 1.6. Weight 3.56. (Fig. 146, 57.)

66. As No. t) 59. *Obverse*: below, [pa] si | ti [mo]. Overstruck (?). *Reverse*: worn away. Diam. 1.7. Weight 3.47. (Fig. 146, 58.)
67. As No. t) 59. *Obverse*: below, pa si | ti mo. *Reverse*: worn away. Diam. 1.6. Weight 3.51. (Fig. 146, 59.)
68. As No. t) 59. *Obverse*: l., pa si le vo; r., se | ti mo ka ri vo se. *Reverse*: above, pa si le vo se; below, ti mo ka ri vo se. Diam. 1.8. Weight 3.81. (Fig. 146, 60.)
69. As No. t) 59. *Obverse*: l., pa si le vo; r., se | ti mo ka ri [vo se]. *Reverse*: above, pa si le vo se; below, ti mo ka ri vo se. Diam. 1.6. Weight 3.41. (Fig. 146, 61.)
70. As No. t) 59. *Obverse*: l., pa si le vo; r., worn away. *Reverse*: inscription above, worn away; below, [ti] mo ka ri vo [se]. Diam. 1.5. Weight 3.29. (Fig. 147, 62.)
71. As No. t) 59. *Obverse*: l., pa si le vo; r., se | ti mo ka ri vo se. *Reverse*: above, pa si le vo se; below, ti mo ka ri vo se. Diam. 1.7. Weight 3.41. (Fig. 147, 63.)
72. As No. t) 59. *Obverse*: l., pa si le vo; r., [se | ti mo ka ri] vo se. *Reverse*: above, pa si le vo se; below, ti mo [ka ri vo se]. Diam. 1.6. Weight 3.45. (Fig. 147, 64.)
73. As No. t) 59. *Obverse*: l., pa si le vo; r., [se | ti] mo ka ri [vo] se. *Reverse*: above, pa si le vo se; below, ti mo ka ri vo se. Diam. 1.8. Weight 3.29. (Fig. 147, 65.)
74. As No. t) 59. *Obverse*: inscription l., worn away; r., worn and indistinct. *Reverse*: above, pa si le vo se; below, [ti] mo ka ri vo se. Diam. 1.6. Weight 3.39. (Fig. 147, 66.)
75. As No. t) 59. *Obverse*: l., pa [si le vo se]; r., [ti mo ka ri vo] se. *Reverse*: above, pa si le vo [se]; below, ti mo ka ri vo [se]. Diam. 1.5. Weight 3.40. (Fig. 147, 67.)
76. As No. t) 59. *Obverse*: worn. *Reverse*: above, pa si le vo se; below, ti mo ka ri vo se. Diam. 1.6. Weight 3.49. (Fig. 147, 68.)
77. As No. t) 59. *Obverse*: dotted circle; l., pa si le vo; r., se | ti mo ka ri vo se. *Reverse*: above, pa si le vo se; below, ti mo ka ri vo se. Diam. 1.6. Weight 3.44. (Fig. 147, 69.)
78. As No. t) 59. *Obverse*: l., pa si le vo; r., [se | ti] mo ka ri [vo se]. *Reverse*: above, pa si le vo se; below, ti mo ka ri vo se. Diam. 1.5. Weight 3.62. (Fig. 147, 70.)
79. As No. t) 59. *Obverse*: l., pa si le vo; r., se | ti mo ka ri vo se. *Reverse*: above, pa si le vo se; below, ti mo ka ri vo se. Diam. 1.7. Weight 3.55. (Fig. 147, 71.)
80. As No. t) 59. *Obverse*: l., pa [si] le [vo]; r., [se | ti mo ka ri vo] se. *Reverse*: above, pa si le vo [se]; below, ti mo ka ri vo [se]. Diam. 1.5. Weight 3.52. (Fig. 147, 72.)
81. As No. t) 59. *Obverse*: l., pa [si le vo]; r., [se | ti mo ka ri] vo se. *Reverse*: above, pa si le vo se; below, [ti mo] ka ri vo se. Diam. 1.6. Weight 3.39. (Fig. 147, 73.)
82. As No. t) 59. *Obverse*: l., pa si le vo; r., se | ti mo ka ri vo se. *Reverse*: above, pa si le vo se; below, [ti] mo ka [ri] vo se. Diam. 1.5. Weight 3.36. (Fig. 147, 74.)
83. As No. t) 59. *Obverse*: entirely worn. *Reverse*: entirely worn. Diam. 1.5. Weight 3.49.
84. As No. t) 83. Diam. 1.5. Weight 3.25.
85. As No. t) 83. Diam. 1.5. Weight 3.37.
86. As No. t) 83. Diam. 1.5. Weight 3.37.
87. Silver diobol, same representation as No. t) 1. *Obverse*: dotted circle; below, pa | ti. *Reverse*: above, pa; below, ti. Diam. 1.2. Weight 1.65. (Fig. 147, 75.)
88. As No. t) 87. Diam. 1.2. Weight 1.53.
89. As No. t) 87. Diam. 1.5. Weight 1.70.
90. As No. t) 87. Diam. 1.2. Weight 1.54.
91. As No. t) 87. Diam. 1.2. Weight 1.67.
92. As No. t) 87. *Reverse*: inscription worn. Diam. 1.3. Weight 1.51.
93. As No. t) 87. Diam. 1.2. Weight 1.68.
94. As No. t) 87. Diam. 1.2. Weight 1.67.
95. As No. t) 87. Diam. 1.2. Weight 1.75.
96. As No. t) 87. *Reverse*: inscription above, worn. Diam. 1.2. Weight 1.53.
97. As No. t) 87. Diam. 1.3. Weight 1.74.
98. As No. t) 87. Diam. 1.3. Weight 1.68.
99. As No. t) 87. Diam. 1.3. Weight 1.70.
100. As No. t) 87. Diam. 1.2. Weight 1.71.
101. As No. t) 87. Diam. 1.3. Weight 1.76.
102. As No. t) 87. *Reverse*: inscription above, worn. Diam. 1.2. Weight 1.56.
103. As No. t) 87. Diam. 1.2. Weight 1.76.
104. As No. t) 87. Diam. 1.3. Weight 1.64.
105. As No. t) 87. Diam. 1.3. Weight 1.65.
106. As No. t) 87. Diam. 1.2. Weight 1.70.
107. As No. t) 87. *Reverse*: inscription below, worn. Diam. 1.3. Weight 1.67.
108. As No. t) 87. Diam. 1.2. Weight 1.65.
109. As No. t) 87. Diam. 1.2. Weight 1.61.
110. As No. t) 87. Diam. 1.2. Weight 1.73.
111. As No. t) 87. Diam. 1.2. Weight 1.65.
112. As No. t) 87. Diam. 1.2. Weight 1.69.
113. As No. t) 87. *Obverse*: inscription worn. Diam. 1.3. Weight 1.60.
114. As No. t) 87. Diam. 1.2. Weight 1.66.
115. As No. t) 87. Diam. 1.3. Weight 1.48.
116. As No. t) 87. Diam. 1.3. Weight 1.66.
117. As No. t) 87. *Obverse*: below, pa [si]. Diam. 1.2. Weight 1.74.
118. As No. t) 87. Diam. 1.2. Weight 1.75.
119. As No. t) 87. Diam. 1.2. Weight 1.62.
120. As No. t) 87. Diam. 1.3. Weight 1.72.
121. As No. t) 87. Diam. 1.3. Weight 1.69.
122. As No. t) 87. *Obverse*: below, pa [si]. Diam. 1.2. Weight 1.74.
123. As No. t) 87. Diam. 1.2. Weight 1.68.
124. As No. t) 87. Diam. 1.3. Weight 1.66.
125. As No. t) 87. Diam. 1.3. Weight 1.57.
126. As No. t) 87. Entirely worn. Diam. 1.2. Weight 1.38.
127. Silver obol, same representation as No. t) 1. *Obverse*: border of dots; below, pa | ti. *Reverse*: the goddess galloping to the left; incuse square; above, pa | ti. Diam. 1.0. Weight 0.81. (Fig. 147, 76.)
128. As No. t) 127. *Reverse*: above, pa | [ti]. Diam. 1.0. Weight 0.75.

129. As No. t) 127. *Obverse*: above, pa ' [ti]. Diam. 0.9. Weight 0.77.
130. As No. t) 127. *Reverse*: inscription worn. Diam. 0.95. Weight 0.77.
131. As No. t) 130. Diam. 0.95. Weight 0.70.
132. As No. t) 127. Diam. 1.0. Weight 0.83.
133. As No. t) 127. Diam. 0.95. Weight 0.88.
134. As No. t) 129. Diam. 1.0. Weight 0.81.
135. As No. t) 127. Diam. 1.0. Weight 0.79.
136. As No. t) 130. Diam. 0.9. Weight 0.60.
137. As No. t) 127. *Obverse*: inscription worn away. Diam. 1.0. Weight 0.88.
138. As No. t) 127. Diam. 0.95. Weight 0.85.
139. As No. t) 130. Diam. 1.0. Weight 0.74.
140. As No. t) 129. Diam. 0.95. Weight 0.84.
141. As No. t) 127. *Obverse*: inscription worn away. *Reverse*: inscription worn away. Diam. 1.0. Weight 0.72.
142. As No. t) 129. Diam. 1.1. Weight 0.86.
143. As No. t) 129. Diam. 1.0. Weight 0.91.
144. As No. t) 127. Diam. 0.95. Weight 0.83.
145. As No. t) 127. *Obverse*: inscription worn away. Diam. 1.0. Weight 0.85.
146. As No. t) 127. Diam. 1.1. Weight 0.87.
147. As No. t) 127. Diam. 0.95. Weight 0.75.
148. As No. t) 127. *Obverse*: inscription worn away. Diam. 1.0. Weight 0.83.
149. As No. 148. Diam. 0.95. Weight 0.81.
150. As No. t) 129. Diam. 0.95. Weight 0.84.
- u) Coins from Kition.
1. Silver stater. *Obverse*: entirely worn. *Reverse*: lion facing right, attacking stag from the left, by jumping on its back; stag facing left, neck bent back; forelegs kneeling, hind legs bent; dotted square within incuse square; above, [L]OΔ[ZOL] Diam. 1.9. Weight 10.62.
2. As No. u) 1. *Obverse*: Herakles, unbearded, with short hair; advancing to the r.; bow in outstretched l. hand; in bent r. hand, his club raised over his head; wearing lion's skin; the forepaws lied over his breast; head hanging at the back of r. shoulder; hind paws hanging down the back at the sides and the tail behind. *Reverse*: neck of stag straight; all the legs kneeling; above, [-]L47LO[AL] Diam. 2.1. Weight 10.74.
3. As No. u) 2. *Obverse*: in field r., ankh symbol. *Reverse*: above, [-]L47LOΔ[L]. Diam. 2.1. Weight 10.74.
4. As No. u) 2. *Obverse*: part of ankh symbol visible; border of dots. *Reverse*: [-]L47LOΔ[L]. Diam. 2.0. Weight 11.10.
5. As No. u) 2. *Obverse*: much worn. *Reverse*: above, [-]L47LOΔ[L]. Diam. 2.1. Weight 10.34.
6. As No. u) 2. *Obverse*: much worn. Diam. 2.0. Weight 10.80.
7. As No. u) 2. *Obverse*: part of ankh symbol visible. *Reverse*: inscription worn. Diam. 1.9. Weight 10.68.
8. As No. u) 2. *Obverse*: part of ankh symbol visible; border of dots. *Reverse*: [-]L47LOΔ[L]. Diam. 2.4. Weight 10.72.
9. As No. u) 2. *Obverse*: rather worn; border of dots. *Reverse*: [-]L47LOΔ[L]. Diam. 2.2. Weight 10.65.
10. *Obverse*: as No u) 2, but head of Herakles missing. *Reverse*: as No. u) 1, but worn. Diam. 1.0. Weight 10.73.
11. Silver stater. *Obverse*: Athena wearing crested Athenian helmet, standing to front; head l.; r. arm resting on spear; l. holding shield; border of dots. *Reverse*: Herakles bearded, wearing lion's skin, flying behind him, the lion's head resting on his r. shoulder; advancing r; wielding club in r.; holding out bow in l.; incuse square. Overstruck. Inscription, see Appendix II. Diam. 2.3. Weight 10.99.
12. As No. u) 11. Inscription, see Appendix II. Diam. 2.5. Weight 10.64.
13. Silver tetrobol. *Obverse*: same representation as No. u) 2, but Herakles figure worn. *Reverse*: same representation as No. u) 1.; above; [L]OΔZO [L]. Diam. 1.3. Weight 3.53.
14. As No. u) 13. *Reverse*: above. [LOΔ]ZOL. Diam. 1.5. Weight 3.63.
15. As No. u) 13. *Obverse*: border of dots, *Reverse*: above, LOΔZOL. Diam. 1.5. Weight 3.46.
16. As No. u) 13. *Obverse*: worn. *Reverse*: above, [LOΔ]ZOL. Diam. 1.4. Weight 3.79.
17. As No. u) 13. *Obverse*: worn; border of dots. *Reverse*: above, [L]O[ΔZ]OL. Diam. 1.4. Weight 3.42.
18. As No. u) 13. *Reverse*: above, [L]OΔZ[OL]. Diam. 1.4. Weight 3.35.
19. As No. u) 13. *Obverse*: entirely worn. *Reverse*: above, [LOΔZ]OL. Diam. 1.4. Weight 3.55.
20. Silver tetrobol, same representation as No. u) 2. *Obverse*: part of ankh symbol visible in r. field. *Reverse*: above, [-]L47LOΔ[L]. Diam. 1.4. Weight 3.06.
21. As No. u) 20. *Obverse*: Ankh symbol worn away. *Reverse*: above, [-]L47LOΔ[L]. Diam. 1.5. Weight 3.44.
22. As No. u) 20. *Obverse*: almost entirely worn away.

- Reverse*: inscription worn away. Diam. 1.4. Weight 3.54.
23. As No. u) 20. *Obverse*: head of Herakles missing. *Reverse*: above, [𐀀𐀃𐀆]𐀇𐀏𐀑[𐀃]. Diam. 1.3. Weight 3.69.
24. As No. u) 20. *Obverse*: part of head of Herakles missing; worn. *Reverse*: above, [𐀀𐀃]𐀆𐀇𐀏𐀑[𐀃]. Diam. 1.4. Weight 3.48.
25. As No. u) 20. *Reverse*: above, [𐀀𐀃]𐀆𐀇𐀏𐀑[𐀃]. Diam. 1.4. Weight 3.38.
26. As No. u) 20. *Obverse*: part of head and r. arm of Herakles missing; ankh symbol in r. field. *Reverse*: above, [𐀀𐀃𐀆]𐀇𐀏𐀑[𐀃]. Diam. 1.4. Weight 3.60.
27. As No. u) 20. *Obverse*: border of dots. *Reverse*: above, [𐀀]𐀃𐀆𐀇𐀏𐀑[𐀃]. Diam. 1.4. Weight 3.55.
28. As No. u) 20. *Obverse*: border of dots; no ankh symbol visible. *Reverse*: above, [𐀀𐀃𐀆]𐀇𐀏[𐀃𐀆]. Diam. 1.4. Weight 3.43.
29. As No. u) 20. *Obverse*: ankh symbol in r. field. *Reverse*: inscription worn away. Diam. 1.3. Weight 3.54.
30. As No. u) 20. *Obverse*: border of dots; no ankh symbol visible. *Reverse*: above, [𐀀𐀃]𐀆𐀇𐀏𐀑𐀃. Diam. 1.4. Weight. 3.75.
31. As No. u) 20. *Reverse*: above, [𐀀𐀃]𐀆𐀇𐀏 [𐀃𐀆]. Diam. 1.3. Weight 3.30.
32. As No. u) 20. *Obverse*: head and r. arm of Herakles missing; ankh symbol in r. field. *Reverse*: inscription worn. Diam. 1.4. Weight 3.50.
33. As No. u) 20. *Obverse*: worn; border of dots. *Reverse*: above, [𐀀]𐀃𐀆𐀇𐀏𐀑𐀃. Diam. 1.5. Weight 3.61.
34. As No. u) 20. *Obverse*: ankh symbol in r. field. *Reverse*: above, [𐀀𐀃𐀆]𐀇𐀏𐀑[𐀃]. Diam. 1.4. Weight 3.51.
35. As No. u) 20. *Obverse*: no ankh symbol. *Reverse*: above, [𐀀]𐀃𐀆𐀇𐀏𐀑[𐀃]. Diam. 1.5. Weight 3.49.
36. As No. u) 20. *Obverse*: no ankh symbol; worn. *Reverse*: above, [𐀀]𐀃𐀆𐀇𐀏[𐀃𐀆]. Diam. 1.4. Weight 3.42.
37. As No. u) 20. *Obverse*: no ankh symbol; worn. *Reverse*: above, [𐀀𐀃𐀆]𐀇𐀏𐀑𐀃. Diam. 1.4. Weight 3.43.
38. As No. u) 20. *Obverse*: ankh symbol in r. field. *Reverse*: above, [𐀀𐀃𐀆]𐀇𐀏𐀑𐀃. Diam. 1.5. Weight 3.49.
39. As No. u) 20. *Obverse*: border of dots; ankh symbol worn away. *Reverse*: [𐀀]𐀃𐀆𐀇𐀏[𐀃𐀆]. Diam. 1.7. Weight 2.63.
40. As No. u) 20. *Obverse*: ankh symbol worn away. *Reverse*: above, [𐀀]𐀃𐀆𐀇𐀏𐀑𐀃. Diam. 1.3. Weight 3.62.
41. As No. u) 20. *Obverse*: ankh symbol worn away. *Reverse*: above, [𐀀𐀃𐀆]𐀇𐀏𐀑[𐀃]. Diam. 1.3. Weight 3.51.
42. As No. u) 20. *Obverse*: head and r. arm of Herakles missing; much worn. *Reverse*: above, [𐀀]𐀃𐀆𐀇𐀏𐀑𐀃. Diam. 1.5. Weight 3.24.
43. Silver diabol, same representation as No. u) 20. *Obverse*: upper part, head, and arm of Herakles missing; border of dots. *Reverse*: above, [𐀀]𐀃𐀆𐀇𐀏[𐀃𐀆]. Diam. 1.0. Weight 1.76.
44. As No. u) 43. *Obverse*: worn. *Reverse*: no inscription visible. Diam. 1.2. Weight 1.57.
45. As No. u) 43. *Obverse*: worn; the whole figure of Herakles preserved; no dots. *Reverse*: worn; no inscription visible. Diam. 1.2. Weight 1.63.
46. As No. u) 45. Diam. 1.2. Weight 1.53.
47. As No. u) 45. *Obverse*: head of Herakles missing. Diam. 1.1. Weight 1.86.
48. As No. u) 45. *Obverse*: upper part of r. arm of Herakles missing; border of dots; worn. Diam. 1.1. Weight 1.65.
49. As No. u) 45. *Obverse*: head and r. arm of Herakles missing. Diam. 1.2. Weight 1.73.
50. As No. u) 45. Representation almost entirely worn away. Diam. 1.1. Weight 1.57.
51. As No. u) 45. Diam. 1.1. Weight 1.55.
52. As No. u) 45. *Obverse*: head and arms of Herakles missing. *Reverse*: not worn, but no inscription visible. Diam. 1.3. Weight 1.79.
53. As No. u) 45. *Obverse*: head and arms of Herakles missing. Diam. 1.1. Weight 1.68.
54. Silver diabol, same representation as No. u) 11. *Reverse*: no inscription. Diam. 1.2. Weight 1.78.
55. As No. u) 54. *Reverse*: in r. field, 𐀀. Diam. 1.2. Weight 1.74.
56. As No. u) 54. *Reverse*: no inscription. Diam. 1.3. Weight 1.69.

57. As No. u) 54. *Reverse*: in l. field, ♀; in r. field, ♂. Diam. 1.3. Weight 1.73.
58. As No. u) 55. Diam. 1.3. Weight 1.53.
59. As No. u) 55. Diam. 1.2. Weight 1.71.
60. Silver obol. *Obverse*: Athena in Athenian helmet, advancing r. with spear over l. shoulder; border of dots. *Reverse*: Herakles, bearded, naked, advancing r.; holding club in vertical r. hand; lion's skin hanging over l. hand, holding out bow; incuse square. Diam. 1.0. Weight 0.80.
61. As No. u) 60. Diam. 1.05. Weight 0.84.
62. As No. u) 60. Diam. 0.9. Weight 0.81.
63. As No. u) 60. Diam. 0.85. Weight 0.73.
64. As No. u) 60. Diam. 1.0. Weight 0.78.
65. As No. u) 60. Diam. 1.0. Weight 0.88.
66. As No. u) 60. Diam. 1.0. Weight 0.70.
67. As No. u) 60. Diam. 1.0. Weight 0.81.
68. As No. u) 60. Diam. 0.95. Weight 0.80.
69. Silver obol. *Obverse*: Herakles head unbearded with lion's head; border of dots. *Reverse*: same representation as No. u) 43; no inscription. Diam. 1.0. Weight 0.92.
- v) Coins from Paphos.
1. Silver stater. *Obverse*: bull standing l. on dotted exergual line; above winged solar disc; to the l., ♀; in exergue, trace of palmette with two spirals springing from the base; border of dots. *Reverse*: eagle standing l.; r., pa si le vo; l., mi ne vo se. Diam. 2.2. Weight 10.76. (Fig. 147, 77.)
2. As No. v) 1. *Obverse*: more worn; part of bull's head missing; part of ♀ to the l.; decoration of exergue worn away. *Reverse*: in front of eagle, ♀ and leaf; r., pa si le vo; l., zo va li o. Diam. 2.1. Weight 10.77. (Fig. 147, 78.)
3. Silver obol. *Obverse*: bull standing l. on exergual line; above winged solar disc; border of dots. *Reverse*: eagle standing r.; in right field olive spray; in l. field, pa | mi; incuse square. Diam. 1.0. Weight 0.85. (Fig. 147, 79.)
4. As No. v) 3. Diam. 1.0. Weight 0.79.
5. As No. v) 3. *Obverse*: much worn. *Reverse*: worn; inscription not visible. Diam. 1.1. Weight 0.84.
6. As No. v) 3. Diam. 1.1. Weight 0.68.
7. As No. v) 5. *Reverse*: [pa] | mi. Diam. 1.05. Weight 0.82.
8. As No. v) 3. Diam. 1.0. Weight 0.86.
9. As No. v) 3. Diam. 1.0. Weight 0.86.
10. As No. v) 3. *Reverse*: no inscription visible. Diam. 1.05. Weight 0.75.
11. As No. v) 3. Diam. 1.1. Weight 0.83.
12. Silver hemiobol. *Obverse*: bucranium; above, winged solar disc; border of dots. *Reverse*: eagle standing l.; in r. field, olive spray; in l. field, pa | mi. Diam. 0.9. Weight 0.39.
13. As No. v) 12. Diam. 0.85. Weight 0.38.
14. As No. v) 12. Diam. 0.85. Weight 0.42.
15. As No. v) 12. *Reverse*: inscription worn. Diam. 0.9. Weight 0.34.
16. As No. v) 12. Diam. 0.85. Weight 0.38.
17. As No. v) 12. Diam. 0.8. Weight 0.43.
18. As No. v) 12. Diam. 0.75. Weight 0.41.
19. Silver hemiobol. *Obverse*: olive spray; border of dots. *Reverse*: as No. v) 12. Diam. 0.8. Weight 0.46.
20. As No. v) 19. Diam. 0.8. Weight 0.45.
- w) Coin from Amathus.
1. Silver stater. *Obverse*: lion lying with open jaws on double, exergual line; above, bird flying r.; border of dots. *Reverse*: Fore-part of lion with open jaws r.; incuse square; square border of dots. Diam. 1.6. Weight 3.61.
- x) Coin from Idalion.
1. Silver obol. *Obverse*: sphinx seated r.; much worn. *Reverse*: Lotus flower; much worn. Diam. 1.0. Weight 0.54.
- y) Coin from Aspendus.
1. Silver stater. *Obverse*: two wrestlers; the one holds with his r. hand the l. leg of the other; border of dots. *Reverse*: slinger to the r., with l. arm discharging sling; wearing short chiton; in front, triskeles of human legs; dotted and incuse square. *EΣΤΕΕ*. Diam. 2.5. Weight 10.75.
- 2) Coins of uncertain provenance.
1. Surface worn; indecipherable. Diam. 0.75. Weight 0.38.
2. As preceding. Diam. 0.80. Weight 0.37.
3. As preceding. Diam. 0.75. Weight 0.32.
4. As preceding. Diam. 0.80. Weight 0.28.
5. As preceding. Diam. 0.75. Weight 0.35.
6. As preceding. Diam. 0.60. Weight 0.14.
293. Fragment of statuette of terracotta in "snow-man" technique; large pellet nose; pellet ears. Top of head, both arms, and base missing. Coarse clay. Height 7.0. Room 44. Floor.
294. Red Figured Attic lekythos with base-ring; slender, oval body; part of body, neck, and handle missing. Figural representation of a bearded man seated on a backed chair; dressed in Persian costume with trousers, tunic with long sleeves, and soft cap; a spear in his l. hand and drinking horn in his r.; open eye. Facing him is a female figure standing; dressed in chiton and folded himation; l. hand stuck in the folds of the himation; r. hand advanced holding bow; upper part of head missing. Behind the male figure, a Doric column by which a palace is indicated, and behind that a female figure standing, resting on l. leg; r. leg slightly bent; dressed in girdled chiton with freely drawn folds; arms bent upwards and holding himation to be wrapped around the figure; head looking r.; eye open; hair tied in a knot; a veil wound around brow. Above, a border of kymation ornaments; below, a meander border. The scene represents the so called warrior's departure. Height 16.5. Room 44. Floor.
295. Plain White VII bowl with flat base; oblique sides; broad, band-shaped rim; small parts missing. Large, central hole and small hole beside it in bottom. Diam. 12.5. Room 44. Floor.

296. Plain White VII amphora with knobbed base; conical body; sloping shoulder, tall, cylindrical neck; swollen rim; straight, bent handles from below rim to shoulder. Damaged. Height 81.5. Room 44. Floor.
297. Plain White VI pithos, as No. 266. Height 68.0. Room 44. Floor.
298. Bronze spatula with straight shaft thickening towards one end; small, oval blade at the other end. Length 18.5. Room 55. Floor.
299. Fragment of a rectangular bronze strip; bordered with parallel, ridged lines. Length 5.0. Room 55. Floor.
300. Bronze mounting in shape of a plaque with two long sides straight and one short side oblique, the other short side and small parts missing; pierced by holes along the edges; decorated with impressed representation of two lions facing each other in heraldic position with heads turned to the r.; the l. lion with l. foreleg and the r. lion with r. foreleg resting on conventionalized tree-ornaments. The heads and bodies of the lions are vigorously modelled; around the edge parallel, ridged lines; upper part of r. lion missing. Length 11.0. Room 55. Floor.
301. Button-shaped, hollow mounting of silver with upper side convex. Diam. 1.5. Room 62. Floor.
302. Statuette of terracotta, representing woman baking. She sits on the ground with an oval trough on her knees; both arms stretched forwards, the hands resting on the bottom of trough; in front of the hands a pellet of clay representing the dough. Edge of trough and fingers marked with red; black transverse line over hands and along the back of woman. Head, neck, and lower part of woman missing; edge of trough chipped. Length 7.5. Room 82. Floor-level.
303. Bronze olive leaf with midrib. Has possibly formed part of a wreath. Length 5.7. Room 81. Floor-level.
304. Plain White VI oval juglet with flat base, narrow, concave neck; ring-shaped rim; handle from rim to shoulder. Part missing. Height 8.5. Room 81. Floor-level.
305. Fragment of a Red Figured guttus with flat base; convex top; large part of body and handle missing. Of the decoration only a swan with raised wings is preserved. Diam. 8.2. Room 81. Floor-level.
306. Statuette of terracotta representing donkey, made in "snow-man" technique; an oblong basket on the back. The legs except r. foreleg, tail, and ends of ears missing. Length 12.5. Room 95. Floor.
307. Fragment of lower part of plank-shaped terracotta statuette with isolinear feet; two vertical folds visible at the middle of body; fringed border marked by incised lines above feet. Reddish clay. Height 6.5. Room 95. Floor.
308. See Temple of Athena.
- 309-310
Fragment of a female statue of more than life-size; only breast (No. 310) and head (No. 309) preserved; the front of breast is completely destroyed; forehead and face missing. The r. arm was once bent at the elbow and the forearm held close to the body; a high diadem is visible at the back of the head and is similar to that of No. 17, but with single rosettes on high stems in the interstices of the figures; at either side of figures and rosettes are bow-shaped, triple stems; below diadem a row of kymation ornament; large spiral earrings with pendants covering the ears; on the shoulders and breast traces of three necklaces; hair falling in a compact mass at back of head to the shoulders. White limestone. Height of head 28.0. Height of torso 58.0. Stray find.
311. Fragment of a stone head. Stray find.
312. Fragment of bronze earring. Diam. 2.5. Room 53. Floor.
313. Fragments of a circular bracelet of bronze. Diam. 5.2. Room 47. Floor.
314. Fragment of statuette of terracotta in "snow-man" technique with l. arm bent over breast. Very much worn. Coarse clay containing small pieces of stone. Height 6.5. Room 53. Floor.
315. Statuette, as No. 306. Legs, nose, ears, and rim of basket on l. side missing. Bright-red clay. Length 7.0. Room 66. Above upper floor.
316. Statuette, as No. 306. Legs, except l. hind leg, r. ear, and part of tail missing. Bright-red clay. Height 9.0. Length 9.0. Room 66. Above upper floor.
317. Red Figured sherd with small remains of a dressed figure; folds indicated by vertical, parallel lines. Length 5.0. Room 66. Below upper floor.
318. Lower part of tubular body of terracotta. Greyish clay. Height 6.0. Room 66. Below lower floor.
319. Wavy bronze handle with flattened base plates, pierced by bronze rivets. Length 8.7. Room 66. Below lower floor.
320. Moulded terracotta head, representing a man with oval head; protruding lips; oval eyes; sloping forehead; the head is shaved. Height 4.4. Room 66. Below lower floor.
321. Head of terracotta, similar to that of No. 485. Reddish clay. Height 4.0. Room 66. Below lower floor.
322. Female terracotta head, moulded, with oval face; straight mouth; nose in line with forehead; eyes of myrtle-leaf shape; front hair parted and rendered by parallel incisions; diadem around head; flat back of head. Worn. Buff clay. Height 2.7. Room 66. Below lower floor.
323. Fragment of a group representing a dog catching a hare; of the dog only fore-part with head preserved. The dog is catching the hare from behind. Conventionalized style. Both heads much worn. White limestone. Length 8.9. Room 66. Below lower floor.
324. Fragment of a pilgrim bottle of green faience; decorated with concentric rows of impressed ornaments consisting of hatched band; bands of dotted string ornaments and guilloche pattern; band of alternating transverse lines and rectangular fields, crossed by one diagonal line and two dots in the other two angles; band of ro-

- settes, straight and semicircular lines; band of ovals; band of alternating lotus flowers and buds; bands of triangles. Length 11.0. Room 66. Below lower floor.
325. a) Black Glazed bowl with moulded base-ring; rounded outline; concave, flaring rim; horizontal handles below rim. Furrowed body. Inside the bottom, impressed ornaments of star of six palmettes encircled by kymation border. Parts of bowl, one handle, and part of the other handle missing. Diam. 13.4.
b) Plain gold wire, rectangular in section. Length 11.8. Room 66. Below lower floor.
326. Small bronze nail with flat, disc-shaped head. Length 1.4. Room 66. Below upper floor.
327. Leaf-shaped arrow-head of iron with midrib; straight tang. Length 5.9. Room 66. Below upper floor.
328. Button-shaped bead of multi-coloured glass with one side flat, the other convex. Diam. 1.0. Room 66. Below upper floor.
329. Fragment of statuette, representing a conventionalized cock, with incised feathers. Head, legs, and end of tail missing. White limestone. Height 8.7. Room 66. Below lower floor.
330. Fragment of the hind part of a sitting animal; upturned tail along the back. White limestone. Height 5.0. Room 66. Below lower floor.
331. Male head of terracotta in "snow-man" technique wearing conical helmet with hanging, long cheek-pieces. Black eyes and beard; red helmet. Nose missing; r. side of helmet and beard chipped. Reddish clay. Height 4.7. Room 66. Below lower floor.
332. Torso of moulded terracotta statuette, representing sitting woman with both hands resting on knees. Head missing. Brown, reddish clay. Height 8.3. Room 66. Below lower floor.
333. Moulded, female head of terracotta with oval face; rather sloping profile; long nose; eyes of myrtle-leaf shape; hair over forehead rendered by parallel incisions. Bright-red clay. Height 3.6. Room 66. Below lower floor.
334. Fragment of head-dress of terracotta, belonging to a statuette. Partly damaged. Grey clay, covered with red paint. Height 4.8. Room 66. Below lower floor.
- 335 + 342.
Torso of a female statuette, similar to No. 61, but with more simplified himation. Head, neck, and feet missing; broken at hips. White limestone. Height 8.8. Room 66. Below lower floor.
336. Gold leaf with impressed decoration of winged demon; details indistinct. Length 2.7. Room 66. Below lower floor.
337. Coarse shallow bowl with flattened base; rounded outline; plain rim. Diam. 11.8. Room 53. Floor.
338. White Painted VI amphoriskos with flat, raised base; oval body; concave neck; flaring rim; horizontal handles on shoulder. Encircling bands around body. Height 14.5. Room 16. Floor.
339. Female head of terracotta, similar to No. 333, but with plain diadem. Height 4.3. Room 66. Below upper floor.
340. Head of terracotta, similar to No. 468, but band around head and another band from forehead to back of head. Dark-grey clay. Height 4.4. Room 66. Below lower floor.
341. Statuette of sitting lion with mane rendered by zigzag notchings; open mouth with outstretched, projecting, licking tongue; round eyes; small ears. Hind part of body missing; only part of forelegs preserved. White limestone. Height 6.5. Room 66. Below lower floor.
342. Fragment belonging to No. 335. Room 66. Below lower floor.
343. Disc-shaped mounting of bronze leaf, pierced by two holes near the edge. Diam. 3.8. Room 66. Below lower floor.
344. Bronze mounting consisting of a thin bronze leaf with curved outline. Length 6.5. Room 66. Below lower floor.
345. Oval head with smiling mouth; strong chin and cheeks; eyes of myrtle-leaf shape; plain diadem around head; long, plain hair. Necklace indicated by red and black dots; lips red; eyes black; vertical, red strokes on diadem. Nose damaged. White limestone. Height 4.0. Room 66. Below lower floor.
346. Plain White VI thimble-shaped miniature vase with flat base; two small, horizontal handles below rim. Height 3.7. Room 66. Below lower floor.
347. Bronze nail with pointed end and large, flattened, button-shaped head; fragment of a similar one. Length 14.7. Room 71. Floor.
348. Iron sickle with curved blade; narrow, flattened tang; part of tang and point missing. Length 43.0. Room 57. Floor.
349. Coarse shallow bowl, as No. 337. Diam. 8.2. Room 57. Floor.
350. Head of terracotta in "snow-man" technique with large pellet nose and pellet ears. Chin missing; nose chipped. Buff clay. Height 5.0. Room 57. Floor.
351. Very shallow bronze bowl with rounded base and plain rim. Diam. 8.9. Room 100. Floor.
352. Circular bronze plate with upturned edge, probably to receive a lamp; square hole in the middle for insertion of the shaft of a lamp-stand. Diam. 8.5. Room 100. Floor.
353. Fragments of bronze mounting which seems to have had a wavy outline; pierced with holes for fixing it. Room 98. Floor.
354. Bronze arrow-head; four-sided; double-curved outline; pointed end; straight tang. Length 7.5. Room 8. Debris below floor-level.
355. Plain White VI oval jug with base-ring; wide neck, widening upwards; plain rim; slightly elevated handle from rim to shoulder. Height 18.6. Room 123. Floor.
356. Oval head with faintly smiling mouth; nose in line with forehead; leaf-shaped eyes; large ears; wreath round head; long hair falling down back of head. Much worn. White limestone. Total height 6.5. Head height 5.8. Length 4.0. Width 3.8. Stray find.

357. Fragment of hand; fingers missing. White limestone. Length 7.5. Stray find.
358. Bronze arrow-head, four-sided; double-curved outline; pointed end; straight tang. Length 6.3. Room 65. Floor.
359. Torso of moulded, female terracotta statuette with rather flat back; r. arm bent over breast, its hand placed between the breasts; l. arm slightly bent along the side, its hand holding some folds of the dress on l. leg; l. leg advanced; wearing folded chiton, girdled at waist, with marked border round neck. Head, neck, both feet, and base missing. Bright-red clay; rather worn. Height 11.5. Stray find.
360. Fragment of a male statuette of terracotta in "snow-man" technique with trapezoid head; rounded beard; pellet mouth; pellet nose and ears; band around head. The man was probably riding some animal. Legs and arms missing. Coarse, red clay. Height 7.0. Stray find.
361. Fragment of the middle part of female statuette with remains of some drapery folds; pitted surface indicating the wool. White limestone. Height 6.0. Stray find.
362. Head of terracotta, similar to No. 360. Bright-red clay. Height 2.3. Stray find.
363. Three-edged bronze arrow-head with concave sides; small, tubular socket. Length 3.8. Stray find.
364. Piece of lead used for fixing shaft of stone column to its base. Room 47. Floor.
365. Piece of lead, similar to No. 364. Room 47. Floor.
366. Fragment of a sphinx, similar to No. 509. Head, neck, legs, and tops of wings missing. Much worn. White limestone. Length 8.0. Found at Loures.
367. Conical bronze pendant, with a ring attached to the top. Length 3.5. Stray find.
368. Oval, female head of terracotta with straight, severe mouth; large, prominent nose; eyes with painted iris; hair over forehead rendered by incised, parallel lines; hair falling down in a plait at either side of neck; plain diadem on head and veil. Flat back. Hair and plaits painted black. Height 3.3. Room 66. Below lower floor.
369. Bronze nail, very thick; flattened, button-shaped head; pointed end missing. Length 9.0. Room 66. Below upper floor.
370. Three-edged arrow-head of bronze with concave sides; pointed end; short, tubular socket. Length 3.0. Room 66. Below upper floor.
371. Arrow-head of bronze, as No. 370. Length 4.0. Room 66. Below upper floor.
372. Fragment of a plank-shaped statuette; plain. White limestone. Height 6.0. Room 66. Below lower floor.
373. Head of a cock; comb and wattles painted red. White limestone. Height 3.7. Room 66. Below lower floor.
374. Lump of cobalt colour. Length 3.7. Room 66. Below lower floor.
375. Ear and horn of terracotta belonging to a bull statuette. Heights 5.5; 2.7. Room 66. Below lower floor.
376. Lower part of female terracotta statuette; much worn. Height 7.0. Room 66. Below lower floor.
377. Small fragments of a bronze sheet; some decorated with a border of impressed dots. Broken in many pieces. Room 66. Below lower floor.
378. Male head with oval face; rounded beard; hanging moustaches; r. eye of myrtle-leaf shape; l. eye marked by a large depression of myrtle-leaf shape, as if the man was one-eyed; front hair in two rows of parallel notchings; wreath around head; hair on top of head rendered by latticed, incised lines; long hair falling down back of neck in plain, parallel plaits. Part of beard and mouth missing; nose damaged. Very soft, white limestone. Height 7.0. Length 4.5. Width 4.3. Room 69. Below floor.
379. Fragment of bull's head of terracotta, rather meticulously worked; incised mouth; modelled nostrils; lancet-shaped, painted eyes, with raised lids. Horns and ears missing. Length 7.0. Room 69. Below floor.
380. Terracotta lamp, as No. 133 c. Handle broken. Length 20.3. Room 12. Floor.
381. Head of terracotta in "snow-man" technique; pear-shaped; protruding nose; pellet ears placed just beneath top of head; eyes painted black; red mouth and ears; black hair. Height 3.0. Room 66. Below lower floor.
382. Fragment of a pyxis lid of dark-red clay, covered with red slip; painted with dark, transverse lines; around the edge, border of filled triangles turned inwards. Length 14.2. Room 66. Below lower floor.
383. Dog's head of terracotta, rather flat and broad; pierced nostrils; incised mouth; bulging eyes; ears laid back. Parts of ears missing. Covered with red paint. Length 4.6. Room 66. Below lower floor.
384. Bronze wire ending in two loops. Length 3.3. Room 66. Below lower floor.
385. Bead of multi-coloured glass; almost cylindrical in shape; pierced by a hole lengthwise. Parts missing. Length 1.4. Room 66. Below lower floor.
386. Fragment of base of terracotta statuette with isolinear feet. Height 3.5. Room 66. Below lower floor.
387. Globular depressed bead of white paste; pierced by a hole. Diam. 0.7. Room 66. Below lower floor.
388. See Temple of Athena.
389. Semicircular mounting of thin bronze leaf; part missing. Diam. 6.4. Room 66. Below lower floor.
390. Female, moulded head of terracotta with rounded, broad chin and cheeks; smiling mouth with full lips; nose chipped; eyes of myrtle-leaf shape; marked eyebrows; hair over forehead parted in the middle and falling in plain, slightly wavy mass. Only front of head preserved. Buff clay; smooth surface. Height 6.8. Room 66. Below lower floor.
391. Fragment of moulded, female terracotta statuette, with flat back; prominent breasts; vertical folds of the dress below breasts; traces of leg with foot (?) at l. side and a thick, upturned projection at r. side. Head, neck, and part below waist missing. The fragment might belong to a group. Height 5.5. Room 13. Floor.

392. 144 lead weights, usually spindle-shaped, but most irregularly shaped. Lengths 1.6—3.8. Weights 21.3; 21.9; 22.7; 24.4; 24.6; 25.5; 26.1; 26.6; 26.8; 26.9; 27.3; 28.0; 28.5; 28.7; 29.2; 29.7; 29.9; 30.1; 30.2; 30.7; 30.9; 31.3; 31.4; 31.9; 32.5; 33.0; 33.1; 33.3; 33.5; 33.7; 33.8; 34.3; 34.7; 34.9; 35.1; 35.4; 35.7; 36.1; 36.5; 36.9; 37.1; 37.4; 37.6; 37.8; 37.9; 39.2; 39.5; 39.8; 39.9; 40.1; 40.4; 41.4; 41.9; 42.4; 43.1; 43.5; 43.9; 44.5; 49.6; 50.1; 50.7. Room 12. Floor.
393. One lead weight, similar to No. 392. Length 2.5. Weight 33.1. Room 12. Floor.
394. Oval, flat loom-weight of terracotta; pierced by a central hole. Diam. 6.0. Room 12. Floor.
395. Fragment of a male statuette of terracotta in "snow-man" technique with wedge-shaped face; band around head and another band attached to the former in front, passing across head and falling down back of head; arms were outstretched, but are missing; only upper part of statuette preserved. Much worn. Coarse, red clay. Height 6.3. Stray find.
- 396 + 397. Fragment of a terracotta statuette in "snow-man" technique, representing a man lying on his l. side; l. arm was bent; r. arm (No. 396) stretched across body, its hand touching the ground. Painted border around neck; an oblique cross over breast; vertical strokes along the arms ending with a transverse stroke; an oblique stroke along the body at back. The base is flattened. Neck, head, l. arm, part of r. shoulder, and legs missing. Light-buff clay. Length 6.0. Room 69. Below floor.
398. Fragment belonging to a female terracotta statuette, as No. 429. Height 6.5. Room 69. Below floor.
399. Fragment of a terracotta statuette in "snow-man" technique with r. arm along side of body; l. arm bent. Only upper part preserved; head and l. forearm missing. Height 7.7. Room 69. Below floor.
400. Fragment of terracotta statuette representing donkey, carrying two baskets on its back, one on either side. Legs, head, and half of baskets missing. Length c. 6.0. Room 69. Below floor.
401. Small fragment of spindle-whorl of stone. Room 69. Below floor.
402. Thin bronze strip; part missing. Length 7.3. Room 69. Below floor.
403. Fragment of a bronze nail. Length 4.9. Room 69. Below floor.
404. Fragment of iron nail with point; hooked. Length 6.5. Room 69. Below floor.
405. Iron nail with knob-shaped head; point missing. Length 6.9. Room 69. Below floor.
406. Fragment of a group of statuettes representing a childbirth, consisting of two figures, one of them holding the confined woman in front of her in her outstretched arms. The confined woman has prominent, pointed breasts, on which traces of black are visible. Lower part of statuette, both heads, and breast of the assistant woman missing. White limestone. Height 7.6. Width 8.0. Breast to back 8.5. Room 69. Below floor.
407. Fragment of bronze strip, with one raised edge preserved. Length 5.9. Room 69. Below floor.
408. Upper part of small, plank-shaped, female statuette with r. arm bent over breast; in the hand, pomegranate between the breasts; l. arm bent upwards, its hand grasping veil; oval head with rounded chin and cheeks; faintly smiling mouth; eyes marked by depressions; plain hair over forehead; plain veil over head falling along sides of neck and along l. hand and arm; necklace around neck hanging over breast with pendant just above the object of r. hand. Broken off below arms. White limestone, rather worn. Height 7.5. Room 11. Floor.
409. Male head with oval face; round, fatty chin and cheeks; slightly smiling mouth; eyes of myrtle-leaf shape; Phrygian cap covering the head; small curls peeping out over forehead. Nose chipped; rather worn. White limestone. Height 3.0. Room 11. Floor.
410. Base with feet; l. foot slightly advanced; part of dress preserved. Traces of red on shoes, of black on dress. White limestone. Length 4.3. Room 11. Floor.
411. Fragment of lower part of terracotta statuette, similar to No. 493. Base and feet missing. Buff clay. Height 6.2. Room 11. Floor.
412. Small Egyptian faience figurine of a male deity; attached to a rectangular, flat pillar on back. Head missing; base chipped. Height 2.35. Room 11. Floor.
413. See Temple of Athena.
414. Red Figured Attic kylix with shallow, rounded body; plain rim; two horizontal handles below rim. One handle, stem, and parts of body missing. Around the outside, a scene representing a group of people in a temple court indicated by a Doric column and a piece of architrave. Two altars with stepped base, moulded upper edge, and kymation ornament below it, are placed diagonally opposite each other below the handles. A frieze of figures between the altars. These are described from right to left, counting from the right altar on the illustration: 1) Male figure leaning on a stick and holding a hare by the ears in his outstretched r. hand; l. leg in profile; r. leg frontal, fore-shortened; dressed in himation with plain folds and bottom border; upper part of body missing. 2) Male figure leaning on a stick; both legs in l. profile; dress as that of No. 1; only lower part of figure preserved. Between Nos. 1 and 2 design of a metal bowl or brazier representing a votive gift hanging on the wall. 3) A seated female on a stool, looking to the l.; dressed in long chiton and himation; only lower part of body preserved. 4) Male figure standing, looking to the r.; leaning on a stick; both feet in profile; holding an object in his r. arm; dressed as No. 1; only lower part of lower body preserved. 5) Female figure, with l. leg on the step of the altar; hands hidden below the folded dress; only middle part of figure preserved. 6) Male figure, looking to the l.;

- leaning on a stick; the outstretched r. arm holds an apple; dressed in folded himation; only middle part of figure preserved. 7) A female figure, standing, facing No. 6; outstretched l. hand in which she holds a flower; hair falls in long plaits down the neck and shoulder, dressed in chiton and himation; lower part of head and middle part of body preserved. 8) Seated female figure, looking to the l.; r. arm outstretched, holding an apple; hair bound up in a veil; eye *en face*; circular rings in ears; dressed in chiton and himation; chair and lower part of body missing. Above the r. arm design of a tripod bowl, evidently a votive gift, hanging on the wall. 9) Male figure leaning on a stick; holding in l. hand double-flute; dressed as No. 1; figure looking to the r.; feet in r. profile; head and shoulders missing. On the inside, the bowl is white-grounded with encircling band around the edge, framing figural representation in the middle a girl servant, standing frontally with box on her l. arm; the box has three drawers and a lid with inlaid or metal mountings; the figure is dressed in a thin chiton with narrow folds and dark-brown himation; only lower part of body and l. arm preserved. To the left, the r. part of a *kline*, its leg ending at the top in a volute capital and decorated with double palmettes and dots. On the *kline*, two cushions. To the r., a backed chair with a fringed seat. The design is in black, brown, yellow, and purple; some of the ornaments are in low relief. Diam. 28.9. Room 13. Layer 3.
415. Red Figured guttus with base-ring; vat-shaped body; neck and handle missing. On each side of body running deer; legs stretched forwards; short tails; large ears. Diam. 11.0. Room 13. Layer 3.
416. Fragment of a shallow, rounded limestone bowl with flat rim; top of rim painted red; below it, row of filled, black triangles; around the bowl secondary ornament of white lotus flowers and buds painted with green colour at their bases; rest covered with red paint Length 9.0. Room 13. Layer 3.
417. Fragment of oval Red Figured lekythos with wide base-ring; part of body, neck, and handle missing. Only fragments of the representation preserved; above, a frieze of kymation ornaments; fragments of standing figure to the r. and a winged figure (probably Tanathos) coming from the l.; between the figures a funnel-shaped object, probably an altar. Height 9.3. Room 13. Layer 3.
418. Crescent-shaped earring of bronze, with overlapping ends. Length 2.8 Room 13 Layer 6.
419. Circular bronze ring, possibly used as a child's bracelet. Diam. 4.0. Room 10. Floor.
420. Three-edged bronze arrow-head with concave sides; small, tubular socket. Length 4.9. Room 10. Floor.
421. Incense-burner of limestone, as No. 247. Complete Height 9.5. Room 10. Floor.
422. Fragment of a rectangular bronze mounting, consisting of a thin strip; framed along the edges by impressed ornaments of gulloche pattern, bordered by ridges. Length 10.0 Room 10. Floor.
423. Rectangular box of terracotta standing on four short, rounded feet. On top of back, four projections pierced horizontally for fixing the lid; knob on front below top. Length 22.0. Width 17.1. Height 13.5. E. deposit.
424. Very shallow bronze bowl with rounded base; splaying, raised rim. Rim broken on one side; embossed all round. Diam. 10.0. E. deposit.
425. Oval grinder of dolerite; flat upper side and rounded base. Length 42.0. Room 13. Layer 3.
426. Incense-burner of limestone, same type as No. 247, but shorter and with short, wide, splayed foot. Height 6.5. Room 10. Floor.
427. Moulded statuette of terracotta, representing woman sitting in a chair with plain sides and back; her hands rest on knees; round, slightly prominent breasts; oval face with nose in line with forehead; curled hair over forehead; hair hanging along sides of neck over shoulders on either side; at waist thin, narrow strip of gold indicating the girdle. Much worn; details of face and dress worn away; part of r. side, of base in front, of l. side, and l. shoulder restored in gypsum. Height 13.0. Room 10. Floor.
428. Female statuette, standing with isolinear feet on small base; holding a tympanon with both hands at the l. side of body; no neck; broad, roundish head; features of face much worn; around head plain diadem; plain hair falling down at back; long chiton with short sleeves. Much worn. White limestone. Height 13.5. Room 10. Floor.
429. Fragment of a moulded, female terracotta statuette with flat body; arms along sides of body; slightly marked breasts; one hair-plait at either side on shoulders, decorated with parallel, vertical, incised lines; at base of neck two rows of necklaces. Only part between neck and waist preserved; much worn; reddish clay. Height 6.5. Room 14. Floor.
430. Plain White VI shallow bowl with rounded outline; flat base; plain rim. Broken. Diam. 11.2. E. deposit.
431. Coarse bowl, as No. 337, but deeper. Diam. 13.2. E. deposit.
432. Plain White VI bowl with small, flat base; gently splaying sides; plain rim; half missing. Diam. 12.0. E. deposit.
433. Coarse bowl, as No. 431. Diam. 11.4. E. deposit.
434. Coarse bowl, as No. 431. Diam. 12.1. E. deposit.
435. Coarse jug with flattened base; squat body; wide, short, concave neck; plain rim; handle from rim to shoulder. Half of jug missing. Height 14.0. E. deposit.
436. Plain White VI shallow miniature bowl with flat base; slightly convex sides; plain rim. Diam. 6.4. E. deposit.
437. Coarse open bowl with flat base; oblique sides; flat, out-turned rim; small parts missing. Diam. 18.4. E. deposit.
438. Coarse lamp, similar to No. 133 c, but with flat, raised base. Part of lamp missing. Length 20.0. E. deposit.
439. Fragment of Plain White VI—VII jug with base-disc;

- depressed body; neck and handle missing. Height 11.0. E. deposit.
440. Coarse bowl, as No. 431, but with flat, raised base. Piece of one side missing. Diam. 11.8. E. deposit.
441. Narrow gold strip, decorated with embossed frieze of palmettes and volutes. Length 5.5. E. deposit.
442. Coarse open bowl with flattened base; rounded outline; flat, out-turned rim; parts missing. Diam. 17.8. E. deposit.
443. Coarse lamp, similar to No. 133 c, but with flat, raised base. Length 15.2. E. deposit.
444. Fragment of moulded, female terracotta mask; diadem and veil around head. Face missing; broken at l. shoulder and head. Worn. Light-buff clay. Height 8.0. E. deposit.
445. Open, saucer-shaped terracotta lamp with flattened base; pinched wick-holder; flattened rim. Length 11.5. E. deposit.
446. Bronze nail with large, flattened, button-shaped head; point missing. Length 9.3. E. deposit.
447. Ithyphallic demon; only roughly shaped, with no sculptured details; rectangular, bearded head; no neck; flattened body; both arms bent across chest; left leg in profile, bent; r. leg missing. White limestone. Height 64.0. Room 28. Floor.
448. Small iron spade with roughly trapezoid blade; flat tang; part of tang missing. Length 7.8. Room 28. In water-basin.
449. Small, moulded terracotta statuette of Bes; seated in frontal attitude with legs widely parted; raised phallus. Height 5.0. Room 14. Floor.
450. Female, moulded head of terracotta with oval face; mass of hair over forehead; bonnet-shaped hair-dress; flat back. Details worn out. Height 4.0. Stray find.
451. Fragment of rider and horse; only body of horse and legs with part of body of rider preserved. He sits on a fringed cloth rendered by large, cut triangles and wears a chiton with folds, and a mantle falling down back. Traces of red on cloth; black fringe; trace of black on chiton. Much worn. White limestone. Length 22.0. Room 69. Below floor.
452. Fragment of a palmette of white limestone. Length 11.0. Room 112. In the earth.
453. Fragment of a White Grounded Attic lekythos with cylindrical body, tapering towards the base; sharply defined, concave shoulder; narrow, concave neck; handle from neck to shoulder. Other parts missing and portions restored in gypsum. On shoulder, an elaborate pattern of palmettes and volutes joined by slings and framed at top by a band of kymation ornaments; below shoulder, an encircling band of framed meander ornaments. Of the figural representation a female figure is preserved. She stands looking to the l. holding something in her r. hand; dressed in chiton and himation with freely designed folds; breasts in profile; straight nose; strong chin; hair with curls in front and tied in a knot at back of head; plain band around head. Purple colour on band around head; face and arms painted white; creamy background. In front of face an inscription (See Appendix III). Height 29.2. Room 13. Layer 5.
454. a) Two arrow-heads of iron; four-sided with straight sides, tapering towards the point. Most of tang missing. Lengths 5.4; 6.5.
b) Two iron arrow-heads; four-sided; double-curved outline; pointed end; straight tang. Length 6.0. Room 13. Layer 5.
455. Loop of bronze wire with pointed ends. Length 3.2. Room 10. Floor.
456. Fragment consisting of animal's paw with triangular claws; on the paw two human feet are standing with marked toes; small part of dress preserved. The fragment is broken off at back of paw. Traces of black on claws; black and red vertical lines on sides; black on human feet. White limestone. Length 8.0. Room 13. Layer 5.
457. Alabastron with almost cylindrical body, slightly tapering upwards; narrow mouth; wide, flat rim; one knob on each side of upper body; broken and part of rim missing. Inferior alabaster. Height 13.5. Room 13. Layer 5.
458. Pieces of alabastra; inferior alabaster. Room 13. Layer 5.
459. Disc-shaped bronze mounting; decorated with a parallel, embossed line pierced by two holes for fixing it. Diam. 12.0. Room 10. Floor.
460. Male head of terracotta in "snow-man" technique; trapezoid head; rounded beard; pellet nose and ears; narrow, conical helmet. Traces of black on beard, r. eye, and helmet. Height 4.5. Room 27. Floor.
461. Lower part of a terracotta statuette; very rudely modelled, in "snow-man" technique; worn. Red clay. Height 5.5. Stray find.
462. L. foot wearing sandal with latticed straps. Small parts missing. White limestone. Length 16.0. Stray find.
463. Two small fragments of a marble bowl. Room 98. Floor.
464. Fragments of a Plain White VI pithos, as No. 266. Room 10. Floor.
465. Fragment of a Plain White VI pithos, as No. 266. Room 10. Floor.
466. Coarse jug with rounded base; depressed body; wide neck, tapering upwards; out-turned rim; handle from rim to shoulder. Part of rim and handle missing. Height 13.8. Room 71. Floor.
467. Fragments of a Plain White VII torpedo-shaped pithos. Room 71. Floor.
468. Head of terracotta in "snow-man" technique; rather square in shape with concave face; broad, rounded beard; pellet nose and ears; top of head is flat; small projection visible above forehead. Height 3.5. Room 118. Floor.
469. Plain White VI shallow bowl with flat base; convex sides; plain rim. Diam. 7.7. Room 118. Floor.

470. Female, moulded head of terracotta with conical cap and a row of curls over forehead; details of face rather worn. Buff clay and slip. Height 3.2. Outside Room 58 in water-conduit.
471. Female, moulded head of terracotta; oval face; rounded chin and cheeks; nose in line with forehead; almond-shaped eyes; slightly marked eyebrows; hair in an elevated mass over forehead and parted in the middle; plain veil covering head. Light buff clay and slip. Height 3.5. Room 120. On rock.
472. Iron arrow-head, four-sided, with slightly double-curved outline; pointed end; straight tang. Most part of tang missing. Length 7.8. Room 12. In the sieves.
473. Incense-burner of limestone of the same type as No. 247, but unfinished. Height 13.2. Room 120. Earth above rock.
474. Bronze nail with pointed end; large, flat, button-shaped head; fragment of another with point missing. Length 10.7. Room 127. Floor.
475. Fragment of hand holding pomegranate. Only two finger tops with marked nails preserved. Flower of pomegranate missing. White limestone; worn. Length 3.6. Room 122. Floor.
476. Female statuette with plank-shaped body; r. arm bent over breast, its hand holding small object; l. arm slightly bent along side of body, its hand holding circular object; sloping shoulders; thick neck; oval, rather broad head with strong, rounded chin and cheeks; slightly smiling mouth; eyes of myrtle-leaf shape; curls of hair over forehead rendered by parallel notchings; plain diadem around head; a necklace hanging over breast in two rows; plain chiton with long sleeves. Feet and small parts of body missing; broken; worn. White limestone. Height 27.0. Room 127. Floor.
477. Female head of terracotta with oval face; smiling lips; rounded chin; full cheeks; narrow eyes of myrtle-leaf shape; arched eyebrows; roughly shaped ears; two rows of parted, spiral-shaped curls over forehead; plaits falling on shoulders; head covered by veil; necklace of pellet beads. Hair, eyebrows, lids, and iris painted black; face covered by a yellow slip. Most of veil, l. ear, jewels of r. ear, lower ends of plaits at l. side missing; nose chipped. Light-red clay. Total height 16.0. Head height 12.4. Width 9.5. Room 129. Deposit of sculptures.
478. Torso of female statuette, similar to No. 61. Head, neck, l. side of body, r. hand, and feet missing. White limestone. Height 30.5. Room 129. Deposit of sculptures.
479. Male, bearded head; details of face entirely worn out. Band, or diadem around head; compact mass of hair over forehead and long hair falling down back of head and along sides of neck leaving ears visible. Chin, part of back of head, and part behind r. ear missing. May belong to Nos. 5 or 6. White limestone. Height 28.0. Cistern outside Rooms 128, 129.
480. Head and part of shoulders belonging to a life-size statue of terracotta, face made in the same mould as No. 52-53-60 b, but the touched-up work more vigorous; similar diadem, but below the pellets hang pear-shaped beads or pendants; the front curls of the hair rendered by circular, flat pellets slightly overlapping each other; spirally twisted plaits on the shoulders. Red clay. Total height 28.0. Head height 19.3. Length 16.7. Width 14.0. Room 129. Deposit of sculptures.
481. Torso of moulded statuette of terracotta standing on high base with isolinear, but diverging feet; r. arm bent across waist, its hand holding some folds of the dress; l. arm slightly bent, its hand holding U-shaped lyre across body, close to l. leg; wearing folded himation wrapped around waist and on l. arm down to feet, leaving upper part of body from waist, nude. Head and neck missing. Buff clay. Total height 28.0. Height of base 5.0. Room 129. Deposit of sculptures.
482. Female statuette, standing on a thin base with r. leg slightly bent; nude feet; r. arm was bent over breast; l. arm slightly advanced, its hand holding a lyre close to the side of body; long, folded chiton with overfold, leaving the breasts uncovered; the folds rendered by vertical grooves; girdle around waist; double bracelets around each upper arm, single bracelet around l. forearm. Head, r. forearm missing; lyre damaged. White limestone. Height 14.3. Room 129. Deposit of sculptures.
483. Group of statuettes representing the rape of a goddess by a mortal. The goddess runs to the l. with l. leg bent and advanced; l. foot in profile; the arms were outstretched and raised; the man comes from the left, he is bent forward, and grips the goddess firmly around her waist with both his arms; his head is placed close to her waist; his chin rests on his r. arm; slightly smiling mouth; nose damaged; eyes of myrtle-leaf shape; short hair, the curls rendered by parallel grooves and small notchings. The goddess is dressed in a long, folded chiton and a short shawl slung over both shoulders; the man wears a short chiton ending above knees, and a shawl over both shoulders falling down at back. The long hair of the goddess is visible at sides and at back of neck. Head, both arms, r. foot of goddess, both feet, r. leg up to knee of man missing. White limestone. Height 15.0. Room 129. Deposit of sculptures.
484. Fragment of a male statuette with l. arm bent over breast; r. arm slightly bent and advanced along side of body. Neck, head, and base missing. White limestone; much worn. Length 14.0. Room 129. Deposit of sculptures.
485. Statuette of terracotta, similar to No. 49, but without diadem and curls of hair at either side of neck. Part of l. side and corner of base missing. Buff clay and slip. Height 19.5. Room 129. Deposit of sculptures.
486. Female statuette with isolinear, but diverging feet standing on small base; anklets around each ankle; r. arm bent over breast, its hand holding small object; bracelet around wrist; l. arm slightly bent along side of body, its hand holding circular object; prominent breasts; sloping shoulders; oval head with rounded,

- heavy chin; disappeared smile on lips; full cheeks; nose in line with forehead; eyes in shape of myrtle-leaf; a heavy mass of hair over forehead parted in the middle; the curls rendered by parallel notches in slightly curved rows; the head is covered by a bonnet-shaped hair-dress consisting of three broad bands wound round the hair, the lowermost of which is decorated with five rosettes in relief; the ears are covered by the hair, only ear-rosettes visible; long, vertically folded chiton with sleeves ending at elbow; the chiton ends in a rounded flap between feet; himation over l. shoulder covering l. arm, falling in shallow, grooved folds obliquely over the body, and gathered at l. side in two vertical folds; necklace of large pendants hanging on shoulders over breast. White limestone. Put together from many pieces. Height 36.0. Shoulder width 9.5. Breast to back 4.4. Waist width 6.5. Head height 5.0. Length 4.7. Width 3.5. Room 129. Deposit of sculptures.
- 487+502. Female statuette, with body as No. 497; oval head (No. 502); rounded chin; slightly smiling mouth; long, straight nose; eyes of myrtle-leaf shape; ears with earrings; thick mass of hair over forehead with curls of cork-screw shape; broad band around hair on head. Put together from many pieces. White limestone. Height 30.5. Room 129. Deposit of sculptures.
488. Female mask of terracotta; oval face; strong, prominent chin; smiling mouth; nose in line with forehead; oblique eyes of myrtle-leaf shape; wavy strings of hair over forehead; diadem around head; ears with disc-shaped pendants. Suspension holes. R. side of face missing; parts of diadem and both inner corners of eyes restored in gypsum. Bright-yellow clay. Height 17.0. Room 129. Deposit of sculptures.
489. Torso of female statuette; flattened body, feet isolinear, but diverging; l. arm advanced, its hand holding small object; long chiton with vertical, grooved folds; himation draped around waist and kept up by l. arm. Head and r. arm missing. Surface much damaged. White, soft limestone. Height 40.0. Room 129. Deposit of sculptures.
490. Male statuette with both arms bent over breast; both hands holding lyre close to body; oblique shoulders; oval head with rounded chin and cheeks; slightly smiling lips; nose in line with forehead; eyes of myrtle-leaf shape; wreath around head; compact mass of hair over forehead; short hair at back of head; ears visible; wearing long, vertically folded chiton with sleeves ending at elbows; red border around neck; red strokes along sleeves and along sides of chiton. Top of head, feet, and lower part of legs missing; broken in pieces. White limestone. Height 15.5. Room 129. Deposit of sculptures.
491. Female statuette, standing with l. leg advanced on irregular base; anklets around ankles; both arms bent, holding tympanon with both hands, slightly oblique shoulders; oval head with plump chin and round cheeks, slightly smiling lips; nose in line with forehead; eyes of myrtle-leaf shape; curled hair over forehead; wreath around head; bonnet-shaped hair-dress covered by a veil which hangs down at back, ending below waist with rounded outline; vertically folded chiton; traces of blue or green on wreath, of black on hair, iris, and eyebrows; red on veil and lips; red borders of vertical, fringed strokes along sides of body. Part of head-dress, and part of r. forearm missing; broken at neck. White limestone. Height 16.5. Room 129. Deposit of sculptures.
492. Fragment of hand holding pomegranate. Only ends of fingers with nails preserved; thumb and flower of pomegranate missing. Length 10.0. Room 129. Deposit of sculptures.
493. Moulded statuette of terracotta, standing on square base; r. arm bent across breast; l. arm slightly bent along side of body, its hand holding some folds of the chiton, the drapery of a wide peplos is girdled at the waist and open at r. side where its vertical folds hang down in thick mass. Neck and head missing; base slightly chipped. Height 17.3. Room 129. Deposit of sculptures.
494. Moulded terracotta statuette, standing with isolinear feet on small base; r. arm bent over breast, its hand placed between them; l. arm slightly bent along side of body, its hand holding some folds of the dress; wearing chiton with long sleeves; himation over l. shoulder falling in parallel, oblique folds at r. side of body. Black border around neck and above feet; the whole front side is covered by dark-red colour. Neck and head missing. Brick-red clay. Height 12.5. Room 129. Deposit of sculptures.
495. Female statuette with plank-shaped body; standing with isolinear feet on small base; r. arm bent over breast, l. arm advanced at side of body; slightly prominent breasts; two chitons, the innermost only visible just above the feet; the outermost visible at breast and below himation with folds rendered by incised, latticed lines, himation over both shoulders covering the arms and falling in double flaps in front at waist; its lower border decorated by incised lines suggesting fringes; necklace around neck with large pendant; bracelets around both wrists. Head, neck, both hands, and part of base missing; parts of body restored in gypsum. White limestone. Height 66.5. Room 129. Deposit of sculptures.
496. Female head with oval face, rounded chin; thick, protruding lips, slightly smiling; eyes of myrtle-leaf shape; compact mass of hair over forehead, the curls rendered by rows of parallel notchings; ears with rosettes; bonnet-shaped hair-dress with hair visible in the middle, the hair rendered by chevrons. Nose and hair in front missing; the eyes almost worn out; the whole head much worn. White, very soft limestone. Total height 11.0. Head height 8.0. Length 5.5. Width 5.7. Room 129. Deposit of sculptures.
497. Female statuette standing with l. leg advanced on trapezoid base; double anklets around each ankle; r. arm bent

- over breast; l. arm slightly bent along side of body, its hand holding some folds of himation; bracelet around wrist and spiral-shaped bracelet above elbow; small, prominent breasts; long chiton ending in a rather long, rounded flap in front with curved, incised folds between feet; himation over l. shoulder with shallow, incised folds obliquely over body; necklace with large beads or pendants. Head, neck, part of r. shoulder, r. hand missing; upper part worn. White limestone. Height 59.2. Room 129. Deposit of sculptures.
498. Fragment of female statuette, similar to No. 497. Head, neck, shoulders, breasts, and part of base missing. White limestone. Height 37.5. Room 129. Deposit of sculptures.
499. Male, plank-shaped statuette; feet standing on small base; r. arm slightly advanced, its hand holding small, circular object; l. arm slightly bent and holding a buck close to the side, its hand grasping the forelegs; the hind legs hanging down along l. side; upper part of buck missing; sloping shoulders; oval head with slightly smiling lips; nose in line with forehead; rounded chin; full cheeks; eyes of myrtle-leaf shape; hair over forehead in rows of parallel notchings; wreath around head; hair on crown of head rendered by radiating grooves; short hair at back of head, the curls rendered by vertical, incised lines and horizontal, parallel notchings; long, vertically folded chiton with sleeves ending at elbows; folded himation over l. shoulder, the folds rendered by shallow, oblique grooves across body; shoes and borders of himation painted red; traces of green colour on himation. Height 51.0. Shoulder width 12.1. Breast to back 4.3. Waist width 10.2. Head height 8.5. Length 5.6. Width 5.0. Room 129. Deposit of sculptures.
500. Female head, oval in shape, with rounded, rather plump chin and cheeks; faint smile on lips; nose in line with forehead; eyes of myrtle-leaf shape; hair over forehead in superimposed, notched rows; bonnet-shaped hair-dress; circular earrings with central dot. Hair, hair-dress, and lips red. Damaged. White, soft limestone. Height 7.0. Length c. 5.5; (with hair-dress) 7.5. Width 4.8. Room 129. Deposit of sculptures.
501. Fragment of terracotta statuette, as No. 49. Only lower part from waist preserved. Light-buff clay; greenish slip. Height 11.5. Room 129. Deposit of sculptures.
502. Head belonging to No. 487. Room 129. Deposit of sculptures.
503. Torso of female statuette, similar to No. 545, but with r. arm bent over breast; l. hand holding three small fruits; borders of chiton and himation painted red; green on himation. Head, part of r. hand, parts of feet and base missing. White limestone. Height 13.4. Room 129. Deposit of sculptures.
- 504-505. Female statuette with r. leg advanced; r. arm along r. side, its hand holding folds of himation; bracelet around wrist; l. arm bent with forearm raised, its hand holding flap of himation falling from l. shoulder; bracelet around wrist, sloping shoulders; prominent breasts, placed obliquely, oval head with round, broad chin, slightly smiling lips; broad nose in line with forehead; large eyes of myrtle-leaf shape, mass of hair over forehead, the curls rendered by incised, latticed lines; plain diadem around head; conical hair-dress; rosette-shaped rings in the lower lobes of ears; between these and the diadem is an elevation consisting of three vertical, well cut ridges, which might represent ear- or hair-rings; necklace with small pendant; folded chiton with short sleeves ending at elbows; folds rendered by vertical grooves; himation wrapped around waist and a flap slung over l. shoulder; oblique folds over body from waist, and a vertical fold from r. hand along r. side of body. Feet missing. Traces of red on hair-dress, diadem, hps, l. iris, necklace, and borders of himation; traces of black on hair. White limestone. Height 37.5. Shoulder width 9.4. Breast to back 4.7. Waist width 7.0. Head height 6.9. Length 4.4. Width 4.3. Room 129. Deposit of sculptures.
506. Fragment of a statuette. Only part below waist with base and feet preserved; two vertical folds in front; a pair of similar ones along r. side, and one fold along l. side; bow-shaped, horizontal folds between. White limestone. Height 11.0. Room 129. Deposit of sculptures.
507. Base with feet wearing shoes; small part of chiton with narrow folds visible. White limestone. Height 5.0. Base 9.0 · 10.5. Room 129. Deposit of sculptures.
508. Base with four paws preserved, belonging to some seated animal. Red border around base. White limestone. Length 9.3. Room 129. Deposit of sculptures.
509. Statuette of sitting sphinx with rounded, slightly bulging breasts; ridges in relief around each breast; wings with sculptured feathers. Neck, head, forelegs, hind paws, and ends of wings missing. Broken through body. White limestone. Height 13.0. Room 124. Floor.
510. Moulded statuette of terracotta representing a woman standing with l. foot slightly advanced on moulded base; r. arm bent over breast, its hand placed between the breasts; l. arm hidden in the dress, the hand is visible in the folds of dress at l. side; oval face with slightly smiling mouth; narrow eyes; hair over forehead modelled in wavy curls; on head a hemispherical hair-dress from which a veil falls down along sides of body; short-rippled hair-plaits falling down over shoulders; wearing Ionian, oblique mantle. Bright-red clay. Height 13.6. Room 124. Floor.
511. Plain White VI almost hemispherical bowl with flat base; plain rim. Diam. 11.5. Room 124. Floor.
512. Torso of female statuette with body and dress as No. 77-78, but more roughly sculptured; l. arm slightly bent and free from body; its hand grasps folds of himation; bracelet around l. wrist. Traces of red on borders of himation and sleeves of chiton. Head, r. hand, and feet missing. White limestone. Height 30.0. Room 124. Floor.

513. Fragment of statuette representing standing man with vertical arms along sides of body; r. hand seems to have held some fold of drapery; plain chiton with short sleeves. Head, neck, and the part below waist missing; r. shoulder broken. White limestone. Height 15.0. Room 130 A. In the earth.
514. Fragment of terracotta statuette in "snow-man" technique with oval head; large, prominent nose; eyes painted black; pellet ears; conical cap with missing point; the arms outstretched (now missing). Black, transverse line from arm to arm over breast. Height 4.5. Room 7 A. Floor.
515. Plain White VI bowl with flat base; rather funnel-shaped body; plain rim. Diam. 9.5. Room 7 A. Floor.
516. Fragment of an ithyphallic demon, as No. 447. L. upper arm, legs, phallus missing; much worn and damaged. White limestone. Height 54.0. Room 7 A.
- 517+518. Head (No. 517) and lower part of life-size terracotta statue (No. 518). The body is preserved up to about the knees; isolinear feet; large shoes with tongues and slightly upturned tips; the folded chiton ends with a wavy outline in a rounded flap between the shoes; oblique, lower border of himation with small, perpendicular folds at either side. The head is oval with rounded chin; sensitive, slightly smiling mouth; smoothly modelled cheeks; nose in line with forehead; eyes of myrtle-leaf shape with modelled lids; row of spiral-shaped curls over forehead, one curl falling vertically in front of each ear; ears with spiral earrings in upper lobe and circular earrings with central dot in relief in lower lobe; diadem around head with a frieze in relief consisting of alternating palmettes and erect lotus buds attached to each other with a wavy trail; below this frieze, a row of kymation ornaments. Traces of black paint on hair, eyelids, and iris; inside of ear red; red himation with black border; red border on chiton. Parts of hair on r. side missing. Reddish clay. Height of lower part 59.5. Height of head 23.0. Room 133. Floor.
519. a) Three-sided arrow-head of bronze; concave sides; pointed end; tubular socket. Length 4.3.
b) Bronze nail with large, flattened head. Length 3.9. Stray find.
520. Female statuette, similar to No. 486, but shorter, wider body and r. arm slightly bent along side of body, its hand holding fold of himation; l. arm bent over breast and holding small object; the himation covers l. arm and hangs down l. side in a vertical fold. Small part of breast, part of fold on l. side, and part of base missing. White limestone. Height 33.5. Room 134. Floor.
521. Male, oval head; rounded, rather narrow chin; smooth, flattened cheeks; lips with disappeared smile; eyes of myrtle-leaf shape; nose in line with forehead; short hair, on crown of head rendered by radiating grooves; over forehead curled hair, rendered by superimposed, notched rows; wreath around head; rather carefully sculptured ears. Traces of black on eyes; lips painted red. White limestone. Total height 8.0. Head height 7.4. Length 6.7. Width 5.5. Room 134. Floor.
522. Coarse jug with round base; squat body; short, wide neck, tapering upwards; out-turned rim; handle from rim to shoulder. Height 9.5. Room 134. Floor.
523. Coarse jar, as No. 292 a. Parts of shoulder and rim missing. Height 22.0. Room 134. Floor.
524. Long, flat bronze handle, rectangular in section, with hooked top. Length 28.5. Room 134. Floor.
525. Curved bronze handle, rectangular in section, ending in circular base-plates with central holes; one base-plate and part of the other missing. Defaced. Length 7.8. Room 134. Floor.
526. Fragment of female statuette; broken and much damaged. The hair-dress seems to have been similar to No. 527. R. hand missing. White limestone. Height 73.0. Room 134. Floor.
527. Female statuette standing on small base with l. leg advanced; double anklet around each ankle; r. arm advanced and free from body; l. arm bent with forearm uplifted; prominent breasts; rather high neck; oval, rather large head; round, heavy chin; rounded cheeks; slightly smiling mouth; nose in line with forehead; large eyes of myrtle-leaf shape; hair-dress as No. 486, but with spiral curls over forehead; the ears covered by the hair, only the earrings visible; wearing chiton ending with a rounded flap between feet and with vertical, wavy folds rendered by grooves; himation over l. shoulder wrapped around body below waist with oblique, incised folds over body; the l. arm is covered by himation and two vertical folds are hanging down along l. side; necklace with large, central pendant. Hair, eyebrows, and iris black; hair-dress, necklace, lips, and borders of himation red. R. forearm and most of l. hand missing. White limestone. Height 39.0. Room 134. Floor.
528. Female statuette with attitude and dress similar to No. 495; wearing two necklaces with pendants; l. hand holding small object. Head, neck, object in r. hand missing. White limestone. Height 50.0. Room 134. Floor.
529. Torso of female statuette with position and dress as No. 512, standing on small base with l. leg slightly advanced; plain shoes on feet. Head, neck, r. shoulder with part of arm missing; upper part much worn. White limestone. Height 32.0. Room 134. Floor.
530. Fragment of a Bichrome Red III (VI) jug with base-ring, oval body; upper part of jug missing. Encircling bands around base and body. Room 134. Floor.
531. Moulded statuette of terracotta with r. arm bent, its hand placed between the breasts; l. arm with hand resting on l. knee; oval head with bonnet-shaped hair-dress; upper part of body seems to be nude; the legs are visible beneath some drapery folds. Worn; buff clay. Height 7.8. Room 134. Floor.
532. Fragment of base with feet and parts of legs; part of folded chiton preserved. White limestone. Much worn. Height 13.5. Room 117. Floor.

533. Torso of statuette standing on small base with isolinear feet; r. arm bent over breast; l. arm slightly bent along side of body. Parts of shoulder, neck, and head missing; surface obliterated. White limestone. Height 68.0. Room 117. Floor.
534. Four fragments of standing statuette a) feet with base, b) drapery with folds rendered by pitted surface to indicate wool; on l. side of fragment folds of himation visible; c) fragment of front of the statuette, joining upper end of b); none of surface preserved, d) fragment of the back, joining to the upper end of b); none of surface preserved. White, very soft limestone; worn. Height of fragments put together 41.0. Room 117. Floor.
535. Plank-shaped statuette; feet almost isolinear, but diverging; arms slightly advanced, with small votive objects in the hands; broad, heavy chin; lips with faint smile; eyes of myrtle-leaf shape; straight nose in line with forehead; thick mass of hair in front with latticed incisions, conical hair-dress, covered by a veil and surrounded by a wreath; long chiton with overfold and sleeves ending at elbows; the folds rendered by shallow, straight, curved, and wavy incisions; girdle around waist, shawl hanging from both shoulders along sides of body and covering the l. arm. Broken in many pieces and small parts missing. White limestone. Height 60.0. Shoulder width 15.5. Breast to back 5.5. Waist width 10.5. Head height 8.8. Length 7.5. Width 6.5. Room 117. Floor.
536. Male statuette with plank-shaped body; r. arm bent over breast; l. arm slightly advanced along side of body, its hand holding a conventionalized bird; broad neck; oval head with straight, severe lips; rounded chin and full cheeks, nose in line with forehead, two rows of curls rendered by notchings over forehead; wreath around head with traces of green colour; hair painted black; folded chiton with long sleeves; folded himation over both shoulders covering r. arm, the folds rendered by rather careless incisions. Lower part of statuette from knees missing. White, very soft limestone. Height 25.5. Room 117. Floor.
537. Incense-burner of bronze with tubular, stemmed, splayed foot; ring-shaped moulding below bowl, small fragments of bowl preserved. Height 21.5. Room 132. Debris below floor.
538. Fragment of plain gold leaf. Length 1.5. Room 132. Debris below floor.
539. Statuette of terracotta, as No. 547. Face missing; surface obliterated. Dark-red clay. Height 11.8. Room 132. Debris below floor.
540. Plain White VI bowl with flat base; slightly convex side, flat rim, down-turned. Diam. 12.4. Room 132. Debris below floor.
541. Bronze shovel, rectangular in shape, with front side plain, the others erect; two holes at back for fixing the shovel to the missing shaft. Small parts missing; rather damaged. Length 14.0. Room 132. Debris below floor.
542. Fragment of a large, disc-shaped mounting of thin bronze leaf. Diam. 13.5. Room 132. Debris below floor.
543. Fragments of bronze sheet. On one fragment a row of kymation ornament in high relief; pierced by two holes at the edge; the other with one straight edge, pierced by a hole, and decorated with two parallel ridges; below them some representations in relief which are nearly worn away. Lengths 4.5; 5.0. Room 132. Debris below floor.
544. Female, moulded head of terracotta with oval face, nose in line with forehead; eyes of myrtle-leaf shape, curled hair (much worn) over forehead; veil on head falling down over shoulders; plain plait falling along either side of neck. Red clay. Height 4.5. Stray find.
545. Female statuette standing on small base with isolinear feet, r. arm stretched downwards with forearm free from body; its hand grasps a group of vertical folds of himation; bracelet around wrist; l. arm bent, covered of a flap of himation which hangs over the forearm; the l. hand carries in the folds of himation seven round fruits; pointed, prominent breasts; sloping shoulders; oval head with softly rounded chin; smiling mouth with slightly protruding lips; rounded, full cheeks; nose in line with forehead; large eyes of myrtle-leaf shape; compact mass of hair over forehead parted in the middle, the curls rendered by incised, latticed lines; bonnet-shaped hair-dress; folded chiton with sleeves ending at elbows; himation on l. shoulder and wrapped around waist with grooved, oblique folds; necklace with small pendant. Hair-dress, necklace, borders of himation and chiton red; traces of black on shoes; faint traces of yellow on chiton. Broken at r. forearm and at neck. White limestone; head blackened by fire. Height 17.8. Found at Loures.
546. Moulded terracotta statuette of sitting woman with isolinear feet; r. arm bent over breast, its hand touching the pendant of the necklace; l. arm lowered and hidden by the drapery at l. hip. Head missing; worn. Dark-red clay. Height 12.0. Found at Loures.
547. Moulded terracotta statuette of sitting woman with isolinear feet; r. arm bent over breast, its hand touching r. breast; the l. arm lowered and hidden by the drapery at l. hip; two necklaces with pendants hanging down over breast; bracelets around r. upper arm; himation with some folds across body. Traces of red and black, oblique lines on himation; traces of red on r. hand and necklaces. Red clay; rather worn; head and neck missing. Height 10.9. Found at Loures.
548. Ithyphallic demon, as No. 447. White limestone. Height 60.0. Room 7 A. Floor.
549. Fragment of stone statuette. Stray find.
550. Fragment of stone statuette. Stray find.
551. Plain White VI bowl with flat base; rounded outline; out-turned rim. Diam. 13.2. Room 30. Below repaired floor.
552. Plain White VI bowl, similar to No. 551, but with plain rim. Diam. 12.0. Room 30. Below repaired floor.

553. Plain White VI bowl, as No. 552. Part missing. Diam 12.7. Room 30. Below repaired floor.
554. Plain White VI bowl with flat base; almost straight sides; flattened, somewhat down-turned rim. Part missing. Diam. 13.3. Room 30. Below repaired floor.
555. Fragment of a Coarse shallow bowl with flat base; rounded outline; plain rim. Half of bowl missing. Diam. 11.5. Room 30. Below repaired floor.
556. Plain White V—VI deep bowl with base-disc; rounded outline; raised, convex rim; horizontal handles below rim; one handle missing. Diam. 18.4. Room 30. Below repaired floor.
557. Coarse bowl, as No. 555. Small parts missing. Diam. 13.7. Room 30. Below repaired floor.
558. Plain White VI bowl with flat base; rounded outline; down-turned rim. Diam. 13.5. Room 30. Below repaired floor.
559. a) Circular bronze earring with overlapping ends. Length 2.0.
b) Silver earring, crescent-shaped, beaded, with overlapping ends. Part missing. Length 1.6. Room 13. In the sieves.
560. Fragments of an iron rod. Length c. 26.0. Room 75. Floor.
561. Fragment of a roughly shaped terracotta bull with short body and broad neck; slightly bulging eyes; tail between hind legs. Legs, nose, and ears missing. Worn. Length 9.5. Room 35. Well.
562. White Painted VI oval jug with raised, flat base-disc; sloping shoulder; short, wide neck tapering upwards; ring-shaped rim; handle from neck to shoulder. Traces of encircling lines and bands around body; surface and decoration almost obliterated. Height 33.5. Room 35. Well.
563. Plain White VI jug with flat base; oval body; rather wide neck, tapering upwards; swollen rim; handle from neck to shoulder. Broken and small parts missing. Height 30.2. Room 35. Well.
564. Coarse jug with flat, raised base; oval body; rather wide neck, slightly tapering upwards; out-turned rim; handle from rim to shoulder. Part of neck and small parts of rim missing. Height 21.7. Room 35. Well.
565. Open, saucer-shaped lamp of terracotta with flattened base; pinched wick-holder; flat, out-turned rim pierced by three holes for hanging the lamp. Broken. Length 12.5. Room 35. Well.
566. Oval bronze jug with flat base; cylindrical, rather short, wide neck; plain rim; elevated handle from rim to shoulder. The handle is fixed to the neck by means of a mounting with two rivets and to the shoulder by means of an oval, flat base-plate. Height 24.1. Room 35. Well.
567. Bronze mounting consisting of a palmette with base volutes and small palmettes in the interstices. Length 8.0. Outside Room 37.
568. Fragment of bull's head of terracotta; only part of neck and parts of horn preserved. Black horns with traces of red. Height 8.0. Earth from Room 110.
569. Plain White VII amphora with knobbed base; conical body; sharply defined, concave shoulder. Neck and handles missing. Height 75.5. Room 108. Floor.
570. Fragment of a Plain White VI pithos, as No. 266. Room 108. Floor.
571. Head of Herakles with tall neck; heavy chin; strong cheeks; smiling mouth; eyes of myrtle-leaf shape; plain ears; hair rendered by a row of notches on forehead; lion-skin over head with marked teeth, nozzle, and eyes; part of club attached to back of head; on either side of neck, lion's mane in twisted plaits. Nose, upper part of l. side of face, part of club, and back of head missing. White limestone. Height 6.0. Chapel of Herakles.
572. Torso of Herakles statuette with l. leg well advanced; r. arm was uplifted (now missing); l. arm slightly advanced along side of body; its hand holds small lion by its tail; plain chiton with sleeves ending at elbows; the chiton ends just above knees in a rounded flap; plain girdle around waist; forepaws of lion-skin, knotted on the breast; hind paws hanging along legs ending just below knees; tail hangs along r. leg. Part of l. leg and r. arm missing; r. leg preserved, but does not fit directly to the body. White limestone. Height 30.0. Chapel of Herakles.
573. Upper part of a Herakles statuette with r. arm uplifted (now missing); l. arm along side of body; forepaws of lion-skin knotted on the breast; chiton ending in a flap between legs; girdle around waist; l. arm has held a small lion, the head of which is visible below shoulder. Head, neck, r. arm, and lower part up to waist missing. White limestone. Height 18.0. Chapel of Herakles.
574. Torso of Herakles with the forepaws of the lion-skin knotted on the breast. Both arms and legs missing. White limestone; much worn. Height 18.0. Chapel of Herakles.
575. Fragments of legs of a nude Herakles statuette with flat back; part of genital organ visible; small lion's head attached to l. thigh. White limestone. Height 16.0. Chapel of Herakles.
576. Lower part of a Herakles statuette with l. leg advanced, wearing plain chiton ending above knees; plain girdle around waist; a lion with head turned back is attached to l. thigh; it has once been held by l. hand (now missing). Lower part up to knees and upper part down to girdle missing. White limestone. Height 22.0. Chapel of Herakles.
577. Lower part of a Herakles torso with l. leg slightly advanced; girdle around waist. Upper part to waist and legs to above knees missing. White limestone; much worn. Height 24.0. Chapel of Herakles.
578. Limestone fragments belonging to a life-size statue:
a) Fragment of l. arm, slightly bent at elbow; strong muscles. Length 28.0.
b) Fragments of r. and l. legs with prominent tibiae. Length of r. leg 34.0. Length of l. leg 34.0.
c) Fragments of r. and l. foot standing on base; toes

- preserved with well sculptured nails. Length of fragment of r. foot 14.0. Length of fragment of l. foot 8.0. Chapel of Herakles.
579. Female head, oval in shape, with strong cheeks, smiling, protruding lips; nose in line with forehead; large eyes of myrtle-leaf shape; slightly sloping, high forehead; ears covered by large rosettes and spiral earrings; the curls rendered by curved rows of notchings; the rest of the hair covered by a cloth and tied up in a knot at back of head; the cloth is wrapped by bands behind front-hair, around hair-knot, and across crown of head; necklace around neck. Traces of red on lips and band of black on hair visible. Chin and nose chipped; part of hair at l. side and top of hair-knot missing. White limestone. Total height 10.5. Head height c. 8.3. Length c. 8.0 (with hair-dress 9.8). Width 7.5. Chapel of Herakles.
580. Fragment of lower part of statuette standing on trapezoid base with l. foot advanced wearing shoes; lower part of himation with rather horizontal folds above feet and a vertical group of folds along l. side preserved. Broken. White limestone. Height 13.0. Chapel of Herakles.
581. Fragment of a woman sitting in a chair with high back, flat body; both arms resting on her knees; broad breast; wide shoulders; short neck; traces of plaits of hair visible at either side of neck. Much worn. Upper and lower parts missing. White limestone. Height 14.0. Width 11.0. Chapel of Herakles.
582. Fragment of Herakles head. White limestone. Chapel of Herakles.
- 583—584. Torso of Herakles with l. leg well advanced; r. arm was uplifted (now missing), l. arm along side of body (now missing), its hand holding lion by its mane; its head turned towards the spectator; forepaws of lion-skin knotted on the breast; plain girdle around waist, chiton ending in a rounded flap between legs. Legs missing. White, very soft limestone. Height 38.0. Chapel of Herakles.

CLASSIFICATION OF FINDS

Pottery (Pls. LXXXI—LXXXVI).

The numerous potsherds found in the different strata of the palace are classified below, pp. 280 ff. The numbered, and more or less intact vases comprise the following classes: White Painted VI, Bichrome Red III (VI), Plain White V—VI, Plain White VI, Plain White VI—VII, Plain White VII, Coarse Ware, Red Figured, White Grounded, and Black Glazed pottery.

White Painted VI is represented by three specimens: an oval jug with base-disc; sloping shoulder; short, wide neck tapering upwards; ring-shaped rim; handle from neck to shoulder; decorated with encircled lines and bands around body (No. 562); an ovoid amphora with base-ring; slightly concave neck; flattened, out-turned rim; horizontal handles on the shoulder; decorated with encircling lines and bands around neck and body; a frieze of leaf-ornament and a wavy line on the shoulder (No. 136); an oval amphoriskos with flat, raised base; concave neck; flaring rim; horizontal handles on the shoulder; decorated with encircling bands around the body (No. 338).

Of Bichrome Red III (VI), only a fragment of an oval jug with base-ring was found (No. 530). It is decorated with encircling bands around the body.

A deep bowl with base-disc; rounded outline; raised, convex rim; and two horizontal handles below the rim (No. 556) is the single representative of Plain White V—VI.

Plain White VI is the commonest of all the pottery classes. It is represented by shallow bowls with flat, raised base; rounded or somewhat straightened outline; plain, out-turned, or flat, down-turned rim (Nos. 133d, 134, 430, 436, 469, 540, 551, 552, 553, 554, 558); almost hemispherical bowl with flat base and plain rim (No. 511); bowl with flat base; gently splaying sides; plain rim (No. 432); funnel-shaped bowl with flat base and plain rim (No.

515); jug with oval body; base-ring; concave neck; plain rim; elevated handle from rim to shoulder (No. 355); jug with oval body; flat base; rather wide neck tapering upwards; swollen rim; handle from rim to shoulder (No. 563); depressed jug with flat base; neck tapering upwards; slightly out-turned rim; handle from rim to shoulder; spout on shoulder opposite the handle (No. 112); bottles with pear-shaped or oval body; narrow, concave neck; ring-shaped rim; handle from rim to shoulder (Nos. 79, 125, 304); jar with oval body; base-disc; erect, concave, ring-shaped rim; two horizontal handles on the shoulder (No. 132); large, bobbin-shaped pithoi with pointed base; rounded shoulder; erect, out-turned rim; two large, erect loop-handles on the shoulder (Nos. 246, 248, 249, 265, 266, 267, 268, 297, 464, 465, 570); thimble-shaped miniature vase (No. 346).

Of Plain White VI—VII there is one jug with base-disc and depressed body (No. 439).

Plain White VII includes the following shapes: funnel-shaped bowls with flat base and plain or band-shaped rim (Nos. 135, 295); jug with flat, raised base; oval body; short neck with erect rim; a handle from neck to shoulder (No. 113); jug with base-disc; depressed body; rather narrow, concave neck; down-turned rim; a handle from rim to shoulder (No. 137); sack-shaped jug with flat base; concave neck; flaring rim; a handle from rim to shoulder (No. 115); amphora with knobbed base; conical body; sloping, rounded shoulder; tall, cylindrical neck; swollen rim; straight, angled handles from neck to shoulder (No. 296); similar amphora but with sharply defined, concave shoulder (No. 569); torpedo-shaped pithos (No. 467).

Coarse Ware comprises the following shapes: shallow bowls with flat base; rounded outline and plain rim (Nos. 142, 145, 285, 337, 349, 431, 433, 434, 440, 555, 557); similar bowls but with flat, or flat, out-turned rim (Nos. 111, 442); similar bowl with flat base; oblique sides; out-turned rim (No. 437); jugs with rounded base; squat body; almost cylindrical, or wide, short, concave neck; plain rim and handle from rim to shoulder (Nos. 261, 435); jugs with rounded base; depressed body; wide neck tapering upwards; out-turned rim and handle from rim to shoulder (Nos. 466, 522); jug with flat, raised base; oval body; rather wide neck tapering upwards; out-turned rim and handle from rim to shoulder (No. 564); jars with rounded base and oval body (Nos. 292 a, 523).

The imported Red Figured pottery is represented by the kylix No. 414; lekythi (Nos. 294, 417); gutti (Nos. 305, 415); the amphora No. 9 and the sherd No. 317. The White Grounded pottery by the lekythos No. 453, and the Black Glazed Ware by bowls (Nos. 226 a, 325 a) and the lekythos No. 141.

The kylix No. 414 has a shallow, rounded body; plain rim; two horizontal handles below the rim; other parts are missing. It is decorated with a figured frieze representing a scene in a courtyard of a temple where persons of both sexes are talking together, some of them bringing their votive offerings. The inside is white-grounded, with a painted representation of a maid servant carrying a box, and flanked by a *kline* to the left and a chair to the right. The lekythos No. 294 has oval, slender body and base-ring; the rest is missing. It is decorated with a figurative scene, the so-called warrior's departure, representing a Persian seated on a chair, and flanked by two female figures. Of the lekythos No. 417, the lower part of the

oval body with base-ring, remains and of the decoration, only part of a standing figure to the right, and a winged figure, probably Thanatos, to the left.

The gutti Nos. 305 and 415, too, are only partly preserved. They are decorated with running deer and swans.

Of the amphora, No. 9, only a fragment of the body is preserved, with the figure of an ephebos on the one side, and Herakles receiving the apples of the Hesperides, on the other.

The White Grounded lekythos No. 453 has a cylindrical body tapering towards the base; sharply defined, concave shoulder; narrow, concave neck and a handle from neck to shoulder; the rest is missing. Of the representation, a female figure is preserved.

The Black Glazed bowls have moulded base-ring; rounded outline; plain rim with ridged line below it (No. 226 a), or concave, flaring rim (No. 325 a); horizontal handles below the rim. The body of No. 325 a, is decorated with furrowed lines. The lekythos No. 141 has conical body; base-disc; sharply defined, horizontal shoulder; narrow, slightly concave neck; short funnel-mouth and a handle from neck to shoulder.

Stone sculptures.

The stone sculptures found at Vouni can be classified in four styles.

Style I (Pls. XLVIII, XLIX).

This style comprises rather few sculptures (Nos. 1 + 30, 2, 14, 17, 26 + 27, 105, 309 + 310, 495, 528). They correspond to the most advanced specimens of Style II at Kition and Style I at Mersinaki, and are characterized by the same features, showing a strong influence of the Ionian Late Archaic art. The head No. 17 is the master-piece of this style. That heads of this type are connected with the torsos attributed to this style, is proved by No. 309 + 310, whose fragmentary head, No. 309, which is of the same type as No. 17, fits torso No. 310.

The sculptures have a flattish body; the feet are isolinear; left arm is slightly advanced and the hand holds a minor object; the right arm is bent across the chest. The dress is of a peculiar kind: it consists of two chitons and a mantle with broad fringes, draped obliquely across the body and over both shoulders; the front of the garment above the legs is cut in a plain surface and the outline of the garment and its folds are designed rather than sculptured; above the waist the body is worked more in the round. Necklaces, pendants, and bracelets ornament the figures. The flat body is a typical Cypriote feature. The type of the heads is represented by No. 17; it is oval in shape, with sharply defined, strong chin; smiling, curved lips; prominent cheeks; straight nose in line with the forehead; narrow, lancet-shaped eyes, slightly oblique; curved, ridged eyebrow lines; the head is crowned by a diadem decorated with relief ornaments of pairs of rosettes alternating with dancing figures, and a border of *kymation* ornaments below; the back of the head is chipped off, but it can be seen from the

similar fragment No. 309+310, of which the back alone is preserved, that the hair fell in contiguous plaits down the neck; in front it peeps out of the fillet with a row of curls and falls in twisted plaits on either side of the cheeks; the ears are ornamented with pendants and above them are large spiral earrings. The Ionian influence is conspicuous but at the same time the Cypriote character is apparent, and the overlaid ornamentation of the head is un-Greek.

The sculptures of this style thus represent a mixture of Cypriote and Ionian art.

Style II (Pls. L—LXI).

This style corresponds to Style III of the Kition sculptures and Style II of the Mersinaki sculptures and, like those styles, it can be divided into two classes, called A and B, and representing typologically early and late stages of the style. Nos. 6, 16+4+24 a+25, 18+92, 63, 77+78, 82, 345, 483, 512, 529, 571, 579 belong to Style II A, and Nos. 5, 28+40+45, 47+43, 61, 85, 120, 262, 290, 409, 476, 500 to Style II B.

The following fragments of sculptures can be attributed to Style II in general but not to any one of its two classes: Nos. 48, 72, 83, 86, 93, 119+259, 251, 252, 256, 335+342, 428, 478, 479, 484, 513, 574, 576.

Some sculptures imitate closely the Greek models, others are more dominated by the Cypriote form. Only a few sculptures, however, show the pure characteristics of these groups; as a matter of fact the two groups are linked to each other by a number of sculptures which represent a mixture of both. In other words, there is a gradual transition from one extreme to the other.

The life-size kore statue No. 16+4+24 a+25 is the supreme representative of the series of sculptures, which closely imitate the Ionian-Greek art. The kore stands with the left leg advanced; she is dressed in a linen chiton and a woollen mantle, which is draped over the left shoulder; the folds of the mantle are gathered in two vertical groups along the left leg and the right side; in the space between these the drapery is marked by a picked surface between curved ridges. The left hand, which is now missing, has held some folds of the mantle in the Ionian fashion. The head is oval with strong, rounded chin and smiling mouth with softly rounded lips; the cheeks are smooth and fleshy; the eyes are lancet-shaped and placed horizontally. Around the head is a diadem decorated with rosettes in relief and the hair falls in contiguous plaits along the back of the head; in front it is collected in a heavy mass from which three, detached plaits fall to the shoulders on either side of the neck. This kore, if compared with head No. 17 of Style I, is not marked by the vigorous, Archaic style which characterizes the latter; the rounded and soft forms, the faint smile, and the horizontal eyes of the kore statue contrast with the sharply defined outline, the vivid smile and the oblique eyes of head No. 17. The kore statue thus represents the last stage of the purely Archaic style.

The female heads Nos. 63, 82, 579 and the Herakles head No. 571 belong to the same group of style: they are representatives of smaller sculptures inspired by *chefs-d'oeuvre*, as the kore

statue mentioned above. All the female heads are of the same type: oval face; strong cheeks and chin; rather long eyes of myrtle-leaf shape; hair wrapped up in a cloth or bands and parted in front over the forehead with superimposed rows of curls. Heads Nos. 63 and 579 are more carefully worked than No. 82. No torso of those preserved fits these heads, but it seems evident that they were of the type represented by torsos Nos. 77-78, 512, and 529. In any case these can be attributed to Style II A which is evident from a comparison with the corresponding figures Nos. 28-40-45 and 61 (cf. below). The torsos are dressed in a thin chiton with short sleeves and an Ionian, oblique mantle; the left leg is advanced; the left hand raises the lower part of the chiton and the right arm is bent across the chest and has held some minor object, now missing. No. 77-78 is of a finer execution than the others: the rippled, transverse folds of the lower part of the chiton are rhythmically grouped, while those of Nos. 512 and 579 fall in monotonous, parallel lines.

The only male torso, which can be attributed to Style II A, is No. 6. It is of the rather full-bodied type and is dressed in a plain himation; the left leg and arm are advanced; the right arm is vertical; the chest is flat and sharply defined.

The statuette No. 18-92 is more Cypriote in type, which is shown, by the plank-shaped body, the Cypriote dress, and the taste for sculptural representation of rich jewellery.

The group of figures No. 483 belongs to the same category. The motif, the rape of a goddess by a mortal, is Greek, but the execution is Cypriote.

The sculptures of Style II B display an increasing influence of the Cypriote form character. It is instructive to compare the figures Nos. 28-40-45 and 61 with the corresponding figures of Style II A (cf. above). Their body is rather flat and the leg is not so much advanced as on the corresponding statuettes of Style II A; the mantle is still of the Ionian, oblique type but the folds are rougher, more conventionalized, and the upper edge of the mantle rounds off the left breast with a deeper, curved edge; the smile is fainter and the mouth almost straight; the back of the head shows a tendency to be flattened and the hair-dress of No. 61 is erect and conical.

It is also interesting to compare the male torso No. 5 of Style II B with No. 6 of Style II A: the attitude of the sculptures is the same but the chest of No. 5 is smoothly rounded; the upper edge of the himation across the breast is more concave; the narrow, incised folds of the chiton and the ridged, curved folds of himation indicate the difference of the linen and woollen stuff.

The statuettes Nos. 47-43 and 476 and the head No. 345 are representatives of the sculptures which are dominated by the Cypriote form character: the body is plank-shaped and the feet isilinear; the dress and heavy necklaces are Cypriote fashion; only the faces show some influence from the Ionian type, but the execution is rough and conventional, so that these statuettes approach the pure idol sculpture.

The relief sculpture No. 290 belongs to the end of Style II and forms a direct transition to Style III. The smile is very faint, the different parts of the face are levelled to a smooth surface, and the eyes are evenly lancet-shaped, while those of the kore statue of Style II A (No. 16-4-24 a-25) are almond-shaped.

Style III (Pls. LXII—LXIX, 1—3).

The sculptures of this style are divided into two classes as in Style II. Nos. 62, 99, 356, 482, 487+502, 489, 503, 521, 535, 545 belong to Style III A, and Nos. 31+32, 378, 486, 490, 491, 496, 497, 499, 504+505, 520, 527 to Style III B. The following fragments of sculptures can be attributed to Style III in general but not to any one of these two classes, viz. Nos. 57, 94, 97, 498, 506, 526, 534, 572, 573, 578, 580, 583+584. The style corresponds to Style IV at Kition and Style III at Mersinaki.

The head of No. 545 is closely related to the relief head No. 290, which was attributed to the end of Style II, and illustrates the direct transition from Style II to Style III. The dress of No. 545, however, shows a new arrangement: the mantle is draped over the left shoulder and around the waist, in purely Greek 5th Century manner; the right hand grasps a fold of the garment and the left hand projects from the folds which cover the arm and carries a dish with pomegranates. No. 503 has the dress arranged in a similar way and seems to be a work of the same artist. The head of No. 487+502 is of the same type but the body is influenced by the Cypriote plank-shaped type, and the mantle which is thrown over the left shoulder is plain, without the rich drapery of the previous sculpture. The Cypriote art is represented by No. 535: the body is entirely plank-shaped, the head is covered by a conical cap surrounded by a wreath; below the cap is a veil hanging down to the shoulders and only leaving the front of the hair free. The dress consists of a chiton with overfold; influence from the drapery style of Nos. 503 and 545 can be traced in the thin, wavy grooves of the chiton. As a rule, the feet of all these sculptures are isolinear or almost isolinear and the position of the arms keeps to traditional attitudes.

Occasionally the figures are seated, e. g. the group No. 62, representing a Cypriote version of Isis with the Horus child. Two figures, Nos. 482 and 489, show an attempt at introducing the Classical-Greek "*Standmotif*"; the left leg supports the weight of the body and the right leg is bent, but there is no displacement of the hips.

The male head No. 521 shows the same stylistic characteristics as the female sculptures described above: the smile has almost disappeared and the features are marked by the stereotyped, Archaistic art which, in Cyprus, succeeded the purely Archaic.

On the sculptures of Style III B, the smile has entirely disappeared, and the forms of Style III A are further standardized so that many of the sculptures are only handicraft work and conventional art of a more and more decadent type. No further attempts are made to develop "*Standmotif*" and the style of the drapery, which in Style III A was partly influenced by contemporary Greek art. The dress is sculptured according to the traditional rules; only the folds are rougher and usually indicated by careless grooves on the plain surface. Unsuccessful attempts to reproduce the fine ripples of the chiton by wavy lines are noteworthy; the upper border of the mantle across the chest is more concave than in Style II, and the lower border of the chiton follows the curve of the feet and descends in a bow-shaped line between them: a characteristic feature of the general slackening of the forms.

Style IV (Pl. LXIX, 4, 5).

This style is represented by only two Vouni sculptures of stone: Nos. 408 and 536. The statuettes are typical specimens of the decadent art, characteristic of this style, which corresponds to Style IV at Mersinaki and Style V at Kition.

Fragments.

Some fragments of sculptures are in such a fragmentary or bad state of conservation that their style cannot be determined with certainty. They include the following specimens: Nos. 3, 8, 20, 21, 22, 23, 24 b, 29, 46, 50, 56, 58, 73, 75, 76, 80, 84, 87, 89, 90, 96 a—b, 102, 106, 109, 110, 114, 257 a—d, 311, 357, 361, 372, 406, 410, 451, 452, 462, 475, 492, 507, 532, 533, 549, 550, 575, 577, 581, 582.

Idols (Pl. LXXVI, 1).

Nos. 447, 516, and 548 cannot be attributed to any of the styles described above. They are specimens of the pure idol type of sculpture (cf. Vol. II, p. 777) and represent roughly shaped, ithyphallic demons with flat body; short neck; large beard; both arms bent across breast; and no face details indicated.

Animal statuettes (Pl. LXXVI, 2—6).

The types represented are: sphinx (Nos. 366, 509); lion (No. 341); cock (Nos. 329, 373); dove (No. 34); hare and dog (No. 323); animal fragments (Nos. 330, 456, 508).

Terracotta sculptures.

The terracotta sculptures are classified into four styles, which run parallel to the four styles of the stone sculptures, but they are characterized by somewhat different, stylistic features on account of the technical difference of the koroplasts' work from that of the stone sculptures: the terracotta heads are moulded, and the moulds are often of Greek origin, but the bodies are of the Cypriote, tubular type and only occasionally made in imitation of the Greek type of body. But as a rule Style I—II of the terracotta sculptures correspond to Styles I—II of the stone sculptures on account of the fact that the latter styles are much influenced by the Greek art, but Style III and still more Style IV of the stone sculptures, which are more and more dominated by the Cypriote form character, are different from the parallel styles of the terracotta sculptures with their moulded, Greek heads.

Apart from the small terracotta statuettes which are classified below under Idols and Figurines, the terracotta sculptures are rather few in number in comparison with the stone sculptures. In fact, there are only 10 specimens which can be attributed to a definite style, and of these, Styles I, III, and IV are each represented by only one specimen, Style II A by 4 specimens, and Style II B by 3 specimens. A complete description of the characteristic

features of the different styles cannot therefore be given on a basis of the Vouni material, but the reader is referred to the description of the corresponding Styles I—IV of the numerous terracotta sculptures found at Mersinaki, pp. 385 ff.

Style I (Pl. LXX, 1).

The only terracotta sculpture assignable to this style is the female mask No. 488. The strong, prominent chin; the oblique, narrow, leaf-shaped eyes; the "Ionian" smile, and strained form of the face are the characteristic features of this head and place it in close, stylistic vicinity to Style I of the stone sculptures.

Style II (Pls. LXX, 2—LXXIII).

The sculptures of this style can be divided into two classes, called A and B, the former represented by Nos. 33, 39, 477, 480, the latter by Nos. 15, 37, 52—53—60 b.

The heads are all moulded and were attached to bodies of a tubular shape, as shown by No. 39, of which the upper part of the body is preserved. It is evident that the heads may have been cast some time after the moulds were made. As a rule, however, the touched-up work of the artist enables us to distinguish earlier and later specimens, and even to attribute heads cast in the same mould to different stages of the same style. Thus the close, stylistic resemblance between the heads of the terracotta figures Nos. 33, 39, 477, 480, and the kore statue No. 16+4—24 a+25 of limestone, makes it certain that these terracottas are really contemporary with the kore statue, and we are therefore justified in including them in Style II A. On the other hand, the touched-up work of the terracottas of Style II B, which are cast in the same mould as those of Style II A, proves them to belong to a later stage of the style. If the head No. 52+53—60 b of Style II B is compared with Nos. 39 and 480 of Style II A, the difference at once becomes clear. In Style II B the touched-up work is of an inferior kind: the modelling of the surface is superficial, the cheeks and chin are slack, heavy, and rather fat, in contradistinction to the vigorous modelling of Style II A.

Style III (Pl. LXXIV).

The only sculpture which can be assigned to this style is No. 517—518. The lower part of the body is preserved up to the knees. The feet are isolinear, encased in large shoes with tongues and upturned tips; the himation is a plain, raised surface; the folds of the chiton are rendered by vertical grooves, and its lower border follows the curve of the feet and descends in a bow-shaped line between them. This is a characteristic feature of the stone sculptures of Style III B, and the whole body structure is typically Cypriote. The head, however, is moulded and more Greek in type; the face is oval; the lips are slightly parted and sensitive; the chin and cheeks are softly modelled, and the expression reflects Greek art at the end of the 5th Century B. C., but the hair-dress, the diadem, and probably the eyelids are Cypriote additions.

Style IV (Pl. LXXV).

Statuette No. 42+74 is the only representative of this style. The figure is seated on a throne, with the feet resting on a footstool; the body is made by hand, fairly roughly shaped, but of an impressive ease of modelling. The head is moulded; it is a specimen of Greek art of the early 4th Century B. C.

Fragments.

Some fragments of sculptures, which cannot with any certainty be attributed to a definite style, include the following numbers: Nos. 12, 13, 55, 60 a, 68, 69, 70, 71, 81, 95, 107, 126, 258, 307, 318, 334, 376, 386.

Animal statuettes (Pl. LXXVII, 1—6).

The animal statuettes are represented by bulls (Nos. 375, 379, 561, 568); horse (No. 130); donkeys (Nos. 306, 315, 316, 400); dogs (Nos. 41, 383); tortoise (No. 279); fragment of a quadruped (No. 117). The tortoise No. 279 is made in a mould; all the other animal statuettes are modelled by hand in the "snow-man" technique.

Idols and Figurines (Pls. LXXVII, 7—LXXX).

These figures, too, are divided into two technical groups: hand-made and moulded.

All the hand-made statuettes are representatives of the idol type of sculpture found in such vast masses at Ajia Irini (cf. Vol. II, pp. 785 ff.). As pointed out in the classification of the Ajia Irini statuettes, the division between these idols and the art sculpture is not always distinct, the carelessly made specimens of the latter and the more meticulously worked specimens of the former sometimes show a transition from one class to the other, and the same holds good for the Vouni statuettes. The majority consists of small statuettes in more or less advanced "snow-man" technique, only occasionally rather meticulously worked (Nos. 116, 148, 293, 314, 331, 340, 350, 360, 362, 368, 381, 395, 396+397, 399, 460, 461, 468, 514); the statuettes of this type include groups of flute-players and dancers (Nos. 123 a, b, c, 124+122) and representations of scenes from the daily life, e. g., woman baking (No. 302). A few statuettes are of large size with tubular, wheel-made, or flat, solid body and a more meticulously worked face (Nos. 67, 88, 118).

Apart from two fragments of a Cypriote Late Archaic type (Nos. 398, 429) represented, e. g., in Arsos (cf. below) and two Egyptian types: a Bes figure (Nos. 449) and a male, shaved head (No. 320), the moulded statuettes consist of a biggish number of Greek figurines (Nos. 19, 35, 36, 38, 44, 49, 51, 64, 65, 66, 98, 100, 108, 121, 128, 129, 143, 144, 146, 253, 269, 321, 322, 332, 333, 339, 359, 390, 391, 411, 427, 444, 450, 470, 471, 481, 485, 493, 494, 501, 510, 531, 539, 544, 546, 547). These have nothing to do with the Cypriote series of sculptures: they are all imported, or made from imported moulds and are of well-known Greek types, the earliest dating from the end of the Archaic period and the latest from the end of

the 5th Century B. C. Some figurines, which evidently are moulded in Cyprus, have details in hair-dress, etc. added by the Cypriote koroplasts, and even a few moulds, e. g., those of Nos. 253, 333, and 494, may be of Cypriote origin.

Iron.

A r r o w - h e a d (Pl. LXXXVII).

1. Leaf-shaped arrow-head with midrib and straight tang (No. 327).
2. Four-sided arrow-head with straight sides; straight tang (454 a).
3. Four-sided arrow-head, as Type 2, but the sides of double-curved outline (Nos. 454 b, 472).

S i c k l e (Pl. LXXXVII).

Sickle with curved blade and narrow, flattened tang (No. 348).

S p a d e (Pl. LXXXVII).

Spade with roughly trapezoid blade and flat tang (No. 448).

N a i l (Pl. LXXXVII).

Nail with knob-head (Nos. 404, 405).

R o d (Pl. LXXXVII).

Only fragments of rods were found, one with bent end (Nos. 280, 560).

Bronze.

S p e a r - h e a d (Pl. LXXXVII).

Four-sided spear-head, tapering towards the point; tubular shaft; moulded ring between spike and shaft; encircling ridges around the shaft (No. 282).

A r r o w - h e a d (Pl. LXXXVII).

1. Four-sided arrow-head; double-curved outline; straight tang (Nos. 277, 278, 354, 358).
2. Three-edged arrow-head, with curved edges and tubular socket (Nos. 283, 363, 370, 371, 420, 519 a).

S h o v e l (Pl. LXXXVII).

Rectangular shovel with raised edges; two holes at the back for fixing to shaft (No. 541).

S p a t u l a (Pl. LXXXVII).

Spatula with straight shaft, thickening towards the one end, and with a small, oval blade at the other (No. 298).

P i n (Pl. LXXXVII).

Straight pin with plain head (No. 273.)

E a r r i n g (Pl. LXXXVII).

1. Circular earring with overlapping ends (No. 559 a).
 2. Crescent-shaped earring with overlapping ends (No. 418).
- Fragments of an earring (No. 312).

B r a c e l e t (Pl. LXXXVII).

Plain, circular bracelet (Nos. 313, 419); No. 419, probably for a child.

P e n d a n t (Pl. LXXXVII).

Conical pendant with a ring (No. 367).

M o u n t i n g (Pls. LXXXVII, LXXXVIII).

The majority of the mountings (Nos. 7, 11, 54 b, 101, 281, 288, 299, 300, 303, 343, 344, 353, 377, 389, 402, 407, 422, 459, 542, 543, 567) are made of a thin sheet and are usually pierced by holes for fixing them to the substructure. Their shape varies: disc-shaped, semi-circular, leaf-shaped, rectangular, or trapezoid. Sometimes they are plain, sometimes decorated with embossed ornaments of parallel ridges, palmettes, volutes, guilloche, and kymation ornaments. No. 300 has an embossed decoration of two lions facing each other in heraldic posture, and flanking a conventionalized tree-ornament.

Only one specimen (No. 276) is socket-shaped, with moulded base and concave sides. It may have been used as a mounting to a spear-head, similar to No. 282.

N a i l a n d l o o p (Pl. LXXXVIII).

The nails (Nos. 59, 103, 104, 131, 260, 274, 284, 326, 347, 369, 403, 446, 474, 519 b) are short or long, with button- or disc-head. The loops consist of a wire ending with a loop at the one end (No. 455), or at both ends (No. 384).

B o w l (Pl. LXXXVIII).

1. Shallow bowl with rounded base and plain rim (No. 351).
2. Shallow bowl as Type 1, but with flattened rim (No. 127).
3. Shallow bowl as Type 1, but with splaying, raised rim (No. 424).

J u g (Pl. LXXXIX).

Oval jug with flat base; cylindrical, rather short, wide neck; plain rim; raised handle from rim to shoulder (No. 566).

I n c e n s e - b u r n e r (Pl. LXXXIX).

Incense-burner with tubular, splayed foot; rounded, shallow bowl; ring-shaped moulding below the bowl (No. 537).

S t a n d (Pl. LXXXIX).

1. Ring-shaped, moulded stand with concave sides, probably used as stand for a vase (Nos. 138, 139, 140).
2. Fragment of a lamp-stand (No. 352).

H a n d l e (Pl. LXXXIX).

The handles are long and flat, rectangular in section, and with hooked top (No. 524); curved, rectangular in section, ending in circular base-plates (No. 525); wave-shaped with flattened bases (No. 319).

L u m p a n d f r a g m e n t.

Lumps or fragments of irregular shape (Nos. 54 a, 226 b, 275).

L e a d (Pl. LXXXIX).

Apart from the pieces of lead (Nos. 364, 365), used for fixing the shaft of stone columns to their bases, the lead objects consist of a number of weights (Nos. 392, 393). The weights are usually spindle-shaped, but some are of various, irregular shapes. Their weights are indicated in the Object Register.

*S i l v e r.**E a r r i n g* (Pl. LXXXIX).

Crescent-shaped earring with overlapping ends (No. 559 b).

P e n d a n t (Pls. LXXXIX, XCII).

1. Cylindrical pendant (No. 292 q).
2. Pendant in the shape of a cicada (No. 292 r).

B r a c e l e t (Pls. LXXXIX, XC, XCII).

1. Cylindrical, flat bracelet; the ends decorated with incised star-ornament (No. 292 m).
2. Circular bracelet, rounded in section; the ends decorated with incised lines (Nos. 292 k, l).
3. Circular bracelet rounded in section, with the ends in the shape of conventionalized snakes' heads (Nos. 292 h, i, j).
4. Spiral bracelet, round in section; plain (No. 292 n).
5. Hollow bracelet, the two halves joined by means of a rivet; overlapping ends in the shape of conventionalized snakes' heads, pierced by holes for insertion of a pin by which the ends were fixed (No. 292 o).

M o u n t i n g (Pl. LXXXIX).

1. Button-shaped, hollow mounting with convex upper side (No. 301).
2. Button-shaped, solid mounting with flat base; convex upper side with two knob-shaped projections; bordered by a circular ring with transverse incisions (No. 272).

B o w l (Pls. XC, XCII).

1. Shallow bowl with rounded base and erect, splayed rim (No. 292 b).
2. Hemispherical bowl with rounded base; erect, concave rim; relief decoration of rosette ornament covering the body and a kymation border around the base of the rim (No. 292 c).
3. Open bowl with moulded base-ring; double-curved outline; plain rim; two horizontal handles below the rim (No. 292 d).

G o l d .

B r a c e l e t (Pls. IV, XCI, XCII).

1. Bracelet of solid gold bar, round in section; roughly oval in shape; bent in opposite the ends which are in the shape of goats' heads (Nos. 292 e, f.).
2. Bracelet, as Type 1, but with ends in the shape of calves' heads (No. 292 g).

M o u n t i n g (Pl. XCIII).

Mountings of thin gold leaf, either plain (No. 538), or decorated with an embossed frieze of palmettes and volutes (No. 441), or impressed, figural representation (No. 336).

W i r e (Pl. XCIII).

Plain wire, rectangular in section (No. 325 b).

L u m p .

Lump of gold (No. 292 p.)

T e r r a c o t t a .

S p i n d l e - w h o r l (Pl. XCIII).

Short, cylindrical, spindle-whorl, pierced by a central hole (No. 286).

L o o m - w e i g h t (Pl. XCIII).

1. Roughly oval loom-weight, tapering towards the pinched top, which is pierced by a transverse hole (No. 10).
2. Oval, flat loom-weight, pierced by a central hole (No. 394).

L a m p (Pl. XCIII).

1. Open, saucer-shaped lamp with flat base; pinched wick-holder; plain or flat rim, occasionally pierced by holes for suspension (Nos. 133, a b, 445, 565).
2. Open, saucer-shaped lamp with flat or flat, raised base; two pinched wick-holders and a horizontal handle (Nos. 133 c, 380, 438, 443).

M o u l d.

Mould for casting terracotta statuette of a female figure (No. 147).

B o x (Pl. XCIII).

Rectangular box standing on four, rounded, short feet; at the back, four projections pierced horizontally for fixing the lid (No. 423). Rectangular lid (No. 382) of another box.

F a i e n c e.

B e a d (Pl. XCIII).

Globular depressed bead of white paste, pierced by a central hole (No. 387).

B o t t l e (Pl. XCIII).

Fragment of a pilgrim bottle of green faience, decorated with concentric, circular bands of incised, geometric ornaments (No. 324).

F i g u r i n e (Pl. XCIII).

Small Egyptian figurine of a male deity attached to a flat, rectangular pillar (No. 412).

G l a s s.

B e a d (Pl. XCIII).

1. Button-shaped bead of multi-coloured glass, with one side flat, the other convex (No. 328).
2. Cylindrical bead of multi-coloured glass, pierced by a longitudinal hole (No. 385).

S t o n e.

S p i n d l e - w h o r l.

Fragment of a spindle-whorl (No. 401).

L o o m - w e i g h t (Pl. XCIV).

Depressed, rounded loom-weight of basalt with a hole bored lengthwise (No. 287).

G r i n d e r.

Oval grinder of dolerite with flat upper side and rounded base (No. 425).

Net-sinker (Pl. XCIV).

Flat disc of limestone, pierced by a central hole; probably used as a net-sinker (No. 271).

Incense-burner (Pl. XCIV).

Incense-burner of limestone, consisting of a rounded, shallow bowl with a ring-moulding below, standing on a wide, conical foot (Nos. 247, 421, 426, 473).

Bowl (Pl. XCIV).

1. Rounded, shallow limestone bowl with flat rim; decorated with painted, floral ornaments (No. 416).
2. Small fragments of a marble bowl (No. 463).

Alabastron (Pl. XCIV).

Alabastron with almost cylindrical body, slightly tapering upwards; narrow mouth; wide, flat rim; one knob on each side of upper body (Nos. 457, 458).

Cover.

Square slab of limestone with a circular projection; used as cover to a large jar (No. 245).

Stele (Pl. XCIV).

Limestone stele, consisting of a papyrus-shaped lower part and a violin-shaped upper part; a rectangular groove on top for insertion of a wooden beam and unfinished relief sculptures of female heads on either side of the violin-shaped part (No. 289).

Architectural fragments (Pl. XCIV).

A piece of stucco (No. 250), covered with red paint, and fragment of a winged sun-disc of limestone, used as a cornice ornament (No. 291).

Pigment.

Lump of cobalt colour (No. 374).

Glyptics.*Scaraboid* (Pl. XCIV).

Oval scaraboid of steatite, pierced by a longitudinal hole (No. 270).

Coins (Pls. XCV—XCVII).

One coin, No. 91, is of bronze; it is Ptolemaic, but so worn that it cannot be identified more exactly. Four coins are of gold: darics struck by Darius¹ (Nos. 292 s:1—2) and Artaxerxes



Fig. 148. Vouni. The palace. Room 10.
Pithoi *in situ*.

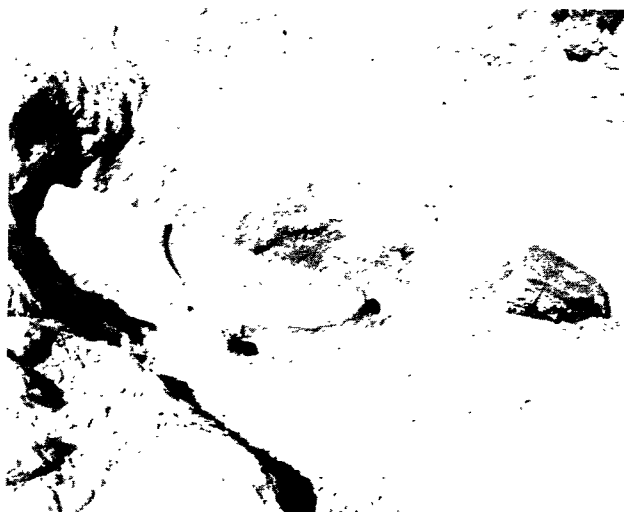

Fig. 149. Vouni. The palace. The fore-court (Room 122)
of the main temenos, with finds Nos. 16 and 17 *in situ*.

xerxes I² (Nos. 292 s:3—4). All the other coins are of silver: staters, tetrabols, diobols, obols, and hemiobols are represented. They are all Cypriote except No. 292 y which is from Aspendus.³ Of the Cypriote coins, Nos. 292 t are from Marion, struck by kings Stasioikos⁴ (Nos. 292 t:1—5, 9, 59—61) and Timocharis⁵ (Nos. 292 t:6—8, 10—58, 62—150) in the latter part of the 5th Century B. C. Nos. 292 u are from Kition, struck by kings Azbaal⁶ (Nos. 292 u:1, 10, 13—19), Baalmelek II⁷ (Nos. 292 u:2—9, 20—53, 69), and Demonikos⁸ (Nos. 292 u:11, 12, 54—68). Nos. 292 v:1—20 are from Paphos,⁹ No. 292 w from Amathus,¹⁰ No. 292 x from Idalion.¹¹ Nos. 292 z:1—6 are of uncertain provenance.

CONDITIONS OF FINDS (FIGS. 148—157; PLANS XXVI, XXVII).

The majority of the objects were found on the floors of the different rooms of the palace and cult-houses, or in the layers of debris covering these floors. Some of these objects were found scattered about; others, and this holds good especially for the sculptures, were found in defined groups.

The largest groups of such objects (Nos. 12—114, 131—144, 355, 474) were found in Rooms 122 and 123, in the fore-court of the main temenos, along the staircase leading to the altar court of the temenos, and in the altar court itself. The bulk of these finds is formed by sculptures of stone and terracotta. These had originally been placed along the staircase leading to the altar court, but were found in a more or less broken state having fallen from their original positions. To judge from the places where they were found, the majority of the terracotta sculptures were placed along the N. E. flank of the staircase and the stone sculptures along the S. W. flank. Several bases of stone sculptures with the feet of the sculptures still preserved, were found there *in situ*, while the remains of the lower bodies of large terracotta sculptures were found *in situ* on the opposite side.



Fig. 150. Vouni. The palace. Room 129 of the main temenos. Sculptures *in situ*.



Fig. 151. Vouni. The palace. Sculptures *in situ* inside the entrance to the altar court (Room 123) of the main temenos.

Similar, but smaller groups of sculptures were found in Rooms 117—118, 124, 129, and 133—134. In Rooms 117—118 and 133—134, the sculptures were found approximately *in situ* placed along the walls of the rooms, while those found in Room 129 seem to have been carried down by rain-water from Room 124. Nos. 423, 424, 430—446 form a group of objects consisting mainly of pottery which was found in a shallow cavity in the rock about 25.0 m. E. of Room 117. This group is called the eastern deposit. It seems that this group of finds has been carried there by a winter-flood from some of the buildings situated higher up the rock.

The deposit of the gold and silver treasure (No. 292) was found in a terracotta jar deposited in the N. corner of Room 59, below the flight of stairs where it evidently had been hidden when the palace was captured and destroyed (cf. p. 288).

Apart from these objects found on the floors, or in the layers of earth covering the floors, some objects were found in filling layers of debris below the floors.

Thus Nos. 9—11 and 258 were found in the filling below the levelled surface of the S. E. courtyard; No. 354 was found below the floor-level of Room 8; Nos. 276—278 were found in the disturbed filling below the floor of Room 39; No. 262 was found in Room 93 below the debris with which the room had been filled in; Nos. 317, 326—328, 339, 369—371

VOUNI

The palace

Finds *in situ* in Rooms 122—123

PLAN XXIV

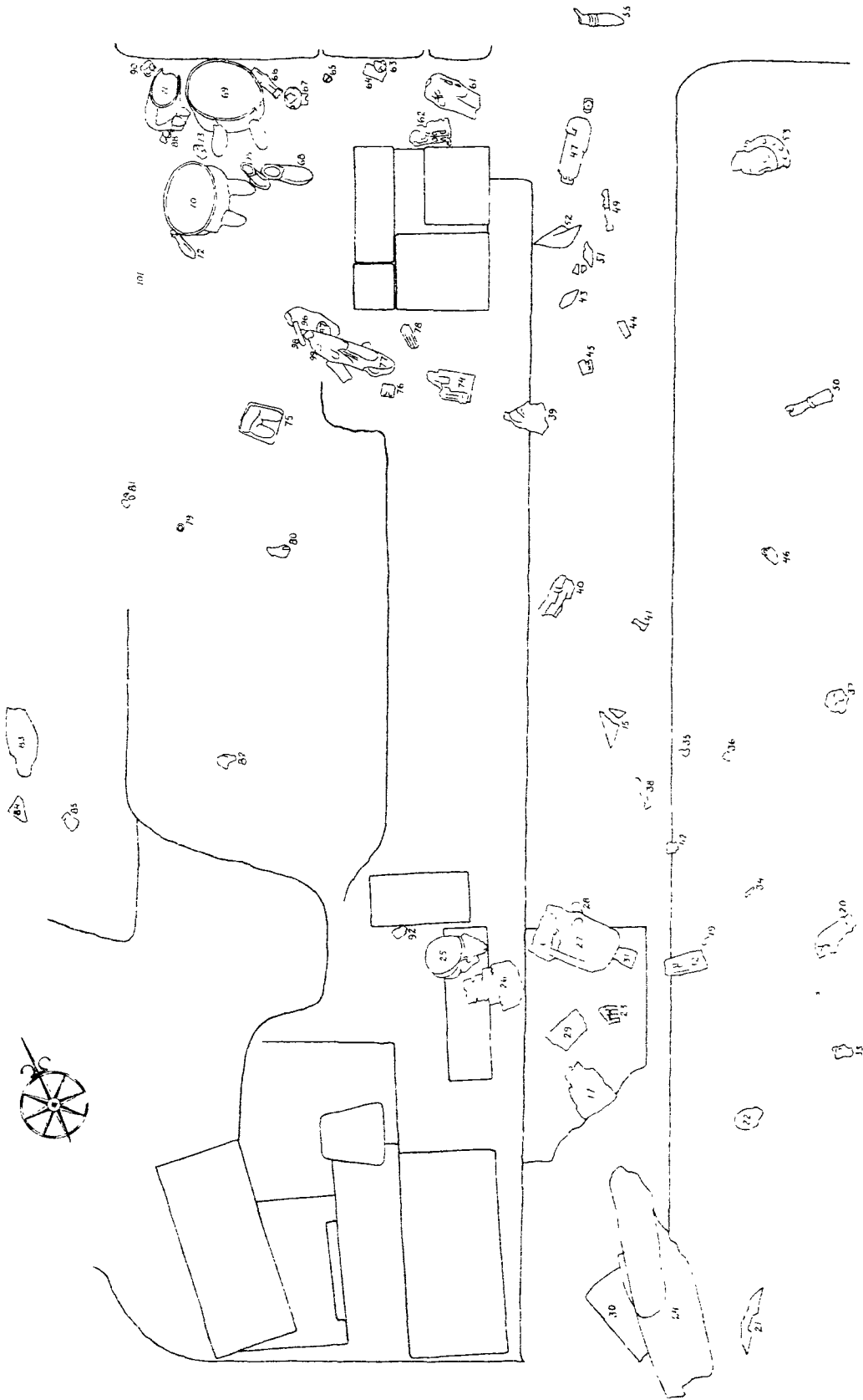

**Finds *in situ*
in Room 124**

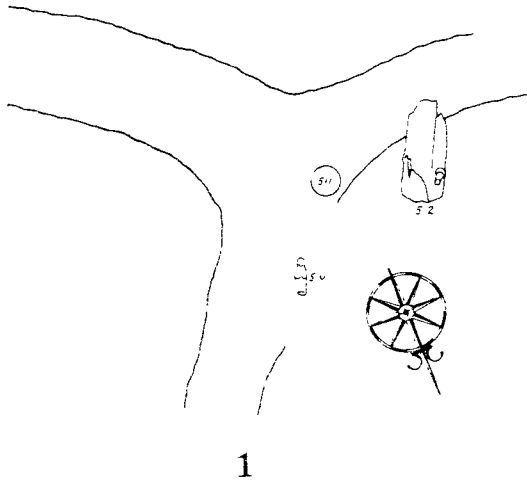

**Finds *in situ*
in Room 129**

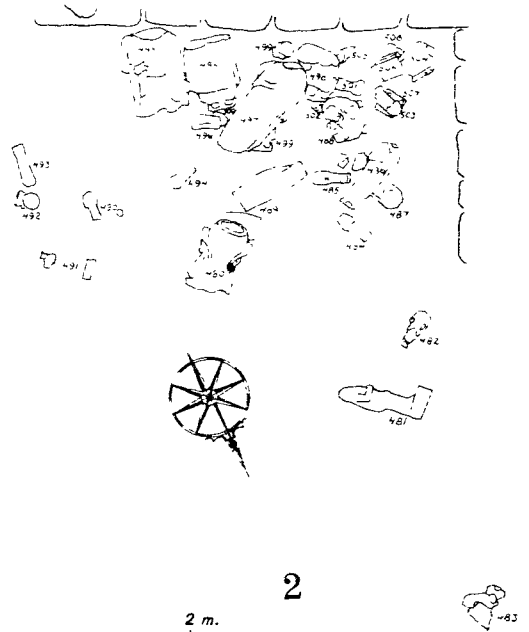

**Finds *in situ*
East deposit**

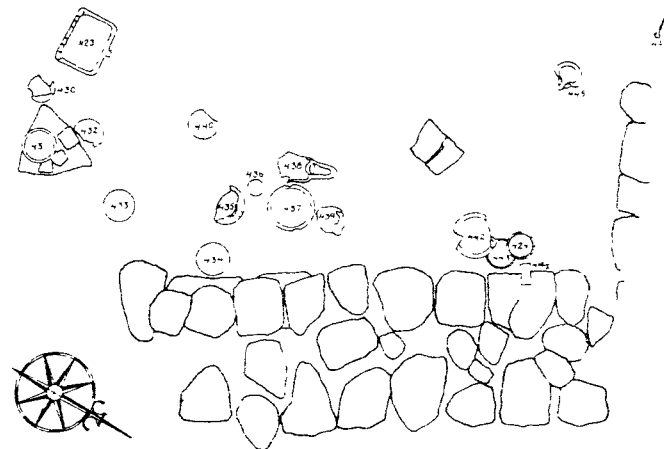



Fig. 152. Vouni. The palace. Sculptures *in situ* inside the entrance to the altar court (Room 123) of the main temenos.



Fig. 153. Vouni. The palace. Sculptures found in Room 129 of the main temenos.

were found in the filling (Layer 3) below the upper floor of the kitchen court, Room 66, and Nos. 318—325, 329—336, 340—346, 368, 372—377, 381—387, 389, 390 in the filling below the lower floor of the same room (Layer 4); Nos. 378, 379, 396—407, 451 were found in the debris (Layer 3) below the floor of Room 69; Nos. 418, 453, 454, 456—458 were found in the filling of the cavity below the floor of Room 13; No. 418 in Layer 6,

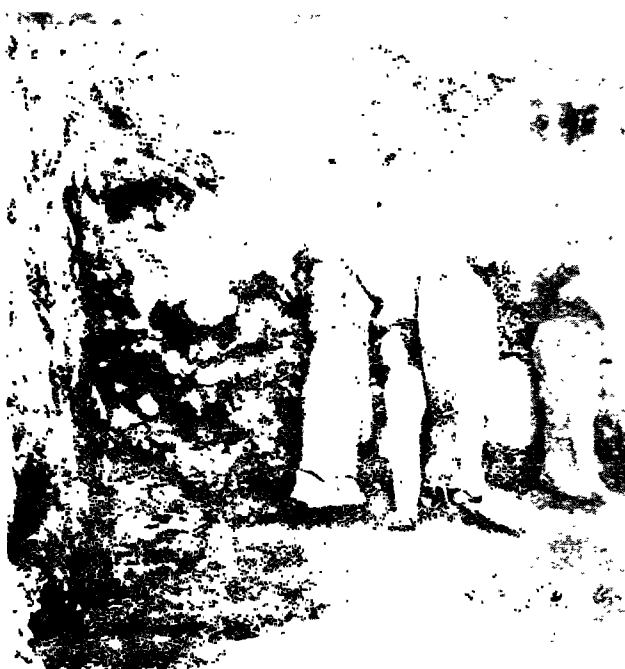

Fig. 154. Vouni. The palace. Sculptures found *in situ* in the chapel, Room 117.

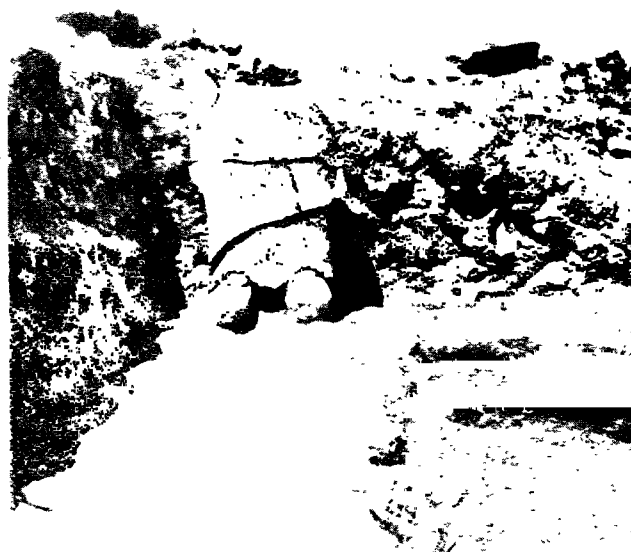

Fig. 155. Vouni. The palace. Lower part of terracotta statue No. 518, found in the chapel, Room 133.



Fig. 156. Vouni. The palace. Room 59. The gold and silver treasure *in situ*.

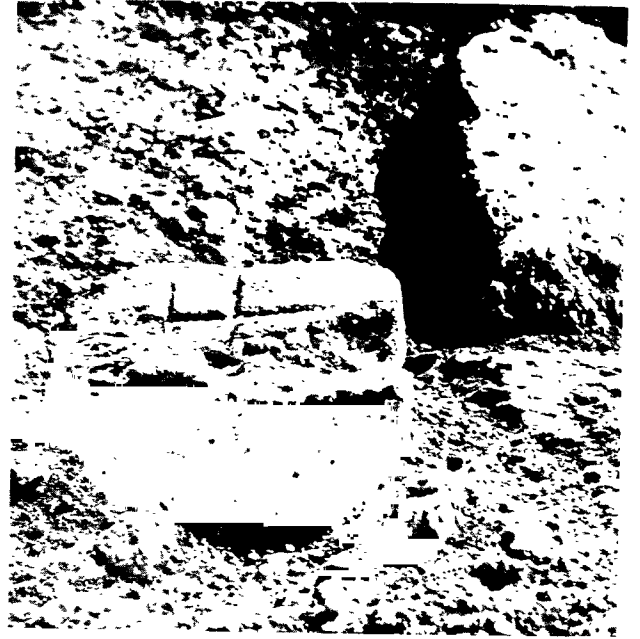

Fig. 157. Vouni. The palace. Room 65. Stone in Wall 180, incised with the syllabary sign for *pa*.

Nos. 453, 454, 456—458 in Layer 5 of the filling. Nos. 551—558 were found below the repaired floor of Room 30, where they evidently had been deposited in connexion with the repair of the floor. Nos. 537—543 were found in the debris below the floor of Room 132. Finally, Nos. 561—566 were found in the well-cistern in Room 35, where they apparently had been dropped while the cistern was in use.

CHRONOLOGY

The chronology of the palace architecture and its four building periods is first and foremost based upon the great number of dateable potsherds and the few intact pots found in the layers below the floors of the different parts of the palace; and the more or less intact specimens of pottery found on these floors. It is evident that the latest potsherds found below the floors afford a *terminus post quem* for the erection of different parts of the palace and the latest pottery found on the floors determine the date of the destruction of the palace. In the Statistical list given below, potsherds are registered from every stratum, which yielded material of importance for the chronology. This list will serve as a basis for the chronological discussion.

	Room 47			
<i>Pre-palace stratum</i>	<i>Below the floor.</i>			
	White Painted V	16		
	Black-on-Red III (V)	12	<i>Pre-palace stratum</i>	
Plain White V	21			
				Rooms 49—52.
				<i>Below the threshold substructure between Rooms 49 and 52.</i>
				White Painted V 11
				Black-on-Red III (V) 3

Red Slip III (V)	1	
Plain White V	8	
"Ionian Cup" fabric	23	<i>Periods 1—2</i>
Black Glazed Greek	2	

Rooms 51—57.

*Below the threshold substructure
between Rooms 51 and 57.*

<i>Pre-palace stratum</i>	White Painted V	2	
	"Ionian Cup" fabric	1	

Rooms 39.

Below the floor, in the filling.

<i>Pre-palace stratum</i>	White Painted V	12	
	Bichrome V	2	
	Black-on-Red III (V)	5	
	Bichrome-Red II (V)	2	
	Red Slip III (V)	4	
	"Ionian Cup" fabric	6	
	Black Figured Greek	3	<i>Pre-palace stratum</i>

*Pre-palace
stratum*

Before Period 2

Room 40.

*Below the floor, in the disturbed
filling along Wall 65.*

<i>Before Period 2</i>	White Painted V	13	
	White Painted VI	4	
	Black-on-Red III (V)	2	
	Bichrome Red III (VI)	3	
	"Ionian Cup" fabric	3	
	Black Glazed Greek (early 5th Century B. C.)	3	

Before Period 2

*Below the floor, in the undisturbed
filling.*

<i>Pre-palace stratum</i>	White Painted V	18	
	Bichrome V	3	
	Black-on-Red III (V)	4	
	"Ionian Cup" fabric	7	

Rooms 62—63.

Between lower and upper floors.

<i>Periods 1—2</i>	White Painted V	14	
	White Painted V—VI	3	
	White Painted VI	15	
	Black-on-Red III (V)	3	
	Red Slip III (V)	1	
	Red Slip IV (VI)	2	
	"Ionian Cup" fabric	2	
	Black Glazed Greek	11	

Periods 3—4

Below lower floor.

<i>Pre-palace stratum</i>	White Painted V	21	
	Black-on-Red III (V)	3	
	"Ionian Cup" fabric	8	

Before Period 3

Room 75+77.

Between lower and upper floors.

White Painted V	29
White Painted VI	13
Black-on-Red III (V)	1
Black-on-Red IV (VI)	1
Red Slip III (V)	2
Plain White V	14
Plain White VI	20
"Ionian Cup" fabric	1
Black Glazed Greek	12

Below lower floor.

White Painted V	7
Black-on-Red III (V)	4
Plain White V	9
"Ionian Cup" fabric	3

Room 87.

Below the floor.

White Painted V	2
Black-on-Red III (V)	4
Black-on-Red IV (VI)	2
"Ionian Cup" fabric	1
Black Glazed Greek	1

Room 92.

Below the floor.

White Painted V	6
White Painted VI	6
Black-on-Red III (V)	9
Black-on-Red IV (VI)	1
Bichrome Red II (V)	1
Black Slip V	1
Black Slip VI	2
Red Slip III (V)	2
Red Slip III (V)—IV(VI)	1
Stroke Polished I (VI)	2
Plain White V—VI	4
"Ionian Cup" fabric	1

Room 13.

*Layer 3 of the filling in the cavity,
above the floor.*

White Painted V	3
White Painted VI	6
White Painted VI—VII	1
Bichrome V	4
Black-on-Red IV (VI)	5
Bichrome Red III (VI)	3
Plain White V	2
Plain White VI	6

*Layer 5 of the filling in the cavity,
below the floor.*

White Painted V	2
White Painted VI	4

	Black-on-Red III (V)	4		
	Black-on-Red IV (VI)	3		
	Bichrome Red II (V)	1		
	Black Slip VI	1		
	Plain White V	6		
	Plain White VI	15		
	"Ionian Cup" fabric	1	<i>Before Period 3</i>	
	Black Glazed Greek	1		
	Red Figured Greek (early 5th Cent. B. C.)	2		
	White Grounded Greek	1		
	<i>Layer 6 of the filling in the cavity, below the floor.</i>			
<i>Pre-palace and Period 1</i>	White Painted V	6		
	Bichrome V	1		
	Black-on-Red III (V)	2		
	Plain White V	12		
	<i>Room 7.</i>			
	<i>Filling below the floor.</i>			
<i>Before Period 3</i>	White Painted V	6	<i>Before Period 3</i>	
	White Painted VI	8		
	Red Slip IV (VI)	2		
	<i>Room 57</i>			
	<i>Below lower floor.</i>			
<i>Before Period 3</i>	White Painted V	1		
	White Painted VI	3		
	Plain White VI	10		
	Black Glazed Greek	9		
	<i>Room 83 (S. E. courtyard).</i>			
	<i>Filling below the floor-level.</i>			
<i>Before Period 3</i>	White Painted V	13	<i>Before Period 3</i>	
	White Painted VI	35		
	Black-on-Red III (V)	1		
	Black-on-Red IV (VI)	3		
	Bichrome Red II (V)—III (VI)	1		
	Plain White V and VI	35		
	"Ionian Cup" fabric	36		
	Black Glazed	101		
	Black Figured	2		
	Red Figured (early and middle 5th Century B. C.)	7		
	<i>Room 95.</i>			
	<i>Below the floor.</i>			
<i>Before Period 3</i>	White Painted VI	7	<i>Before Period 3</i>	
	Plain White VI	12		
	Black Glazed Greek	5		
	<i>Room 66.</i>			
	<i>Below the upper floor</i>			
<i>Before Period 4</i>	White Painted VI	5		
	White Painted VI—VII	2		
	Plain White VI	20		
	Plain White VII	7		
	Black Glazed Greek	6		
	<i>Square B 1. Filling below lower floor-level.</i>			
	White Painted V	18		
	White Painted VI	56		
	Bichrome V	1		
	Black-on-Red III (V)	2		
	Black-on-Red IV (VI)	6		
	Bichrome Red II (V)	2		
	Bichrome Red III (VI)	5		
	Red Slip III (V)	1		
	Red Slip IV (VI)	5		
	Plain White V and VI	23		
	"Ionian Cup" fabric	1		
	Black Glazed Greek	16		
	<i>Square B 2. Filling below lower floor-level.</i>			
	White Painted V	5		
	White Painted VI	25		
	Bichrome V	2		
	Black-on-Red III (V)	1		
	Black-on-Red IV (VI)	3		
	Bichrome Red III (VI)	1		
	Plain White VI	18		
	"Ionian Cup" fabric	2		
	Black Glazed Greek	3		
	<i>Square B 3. Filling below lower floor-level.</i>			
	White Painted V	19		
	White Painted VI	52		
	Bichrome VI	2		
	Black-on-Red III (V)	2		
	Black-on-Red IV (VI)	4		
	Bichrome Red II (V)	4		
	Bichrome Red III (VI)	4		
	Stroke Polished I (VI)	2		
	Plain White V and VI	27		
	"Ionian Cup" fabric	2		
	Black Glazed Greek	25		
	<i>Square B 4. Filling below lower floor-level.</i>			
	White Painted V	11		
	White Painted VI	40		
	Bichrome V	1		
	Black-on-Red III (V)	2		
	Black-on-Red IV (VI)	5		
	Bichrome Red II (V)	1		
	Black Slip VI	1		
	Plain White V and VI	29		
	"Ionian Cup" fabric	3		
	Black Glazed Greek	41		

	Room 64.			<i>Below the middle floor.</i>
	<i>Below the uppermost floor.</i>	Periods 1-2		
<i>Before Period 4</i>	White Painted VI 4			White Painted V 4
	Stroke Polished II (VII) 2			White Painted VI 12
	Plain White VI 16			Bichrome V 2
	Plain White VII 5			Black-on-Red III (V) 3
	Black Glazed Greek 13			Black-on-Red IV (VI) 2
				Plain White V 11
				Plain White VI 9
				Black Glazed Greek 6

On an examination of the composition of the pottery types in the strata registered above, we find that we can distinguish five main groups of pottery.

Group 1 consists entirely of potsherds of Type V: White Painted and Bichrome V, Black-on-Red III (V), Bichrome Red II (V), Red Slip III (V), and Plain White V, together with sherds of foreign wares: "Ionian Cup" fabric, Black Glazed, and Black Figured Greek pottery. This group is represented by the pottery found in Layer 6 of the filling in the cavity below the floor of Room 13, below the floor of the central court (Room 47), below the threshold substructure between Rooms 49-52 and 51-57, below the lower floor of Rooms 62-63, 75-77, in the undisturbed filling below the floor of Room 40, and below the floor of Room 39.

Group 2 consists of potsherds of Type V mixed with a few sherds of Type VI: White Painted V-VI, Black-on-Red III (V)-IV (VI), Bichrome Red II (V)-III (VI), Black Slip V-VI, Red Slip III (V)-IV (VI), Stroke Polished I (VI), and Plain White V-VI. The foreign wares, found together with this Cypriote pottery, consist of a very few specimens of the "Ionian Cup" fabric, and some Black Glazed, Black Figured, and Red Figured Greek sherds of the early 5th Century B. C. This group is represented by the pottery found below the floors of Rooms 87 and 92, and in the disturbed filling below the floor of Room 40.

In Group 3 the composition of the pottery types has changed, so that there is a numerical equilibrium between the pottery of Types V and VI which are represented by the following classes: White Painted V-VI, Black-on-Red III (V)-IV (VI), Bichrome Red II (V), Black Slip VI, Red Slip III (V)-IV (VI), and Plain White V-VI. Of the foreign ware, the "Ionian Cup" fabric occurs only sporadically, while the Black Glazed Greek pottery fragments are more numerous. This group is represented by the pottery found between the upper and lower floors of Rooms 62-63, 75-77, and between the lower and middle floors of Room 64.

The pottery of Group 4 consists of the same classes as the preceding group, but the proportion between the wares of Type V and VI has changed, so that there is a considerable majority of Type VI and a minority of Type V. If we disregard the Plain White Ware, in which Types V and VI are sometimes not easily distinguishable owing to the small size of the pottery fragments, there are 93 specimens of Type V against 287 specimens of Type VI in the whole material of this group registered above. The "Ionian Cup" fabric is represented by stray specimens, the Black Figured, Red Figured, and White Grounded Greek pottery of the first part of the 5th Century B. C. by a small number of sherds, and the Black Glazed Greek

pottery by many specimens. This group is represented by the pottery found in Layer 5 of the filling below Room 13, below the floor of Room 95, below the lower floors of Rooms 57 and 66, in the fillings below the floors of Room 7 and the S. E. courtyard (Room 83).

The pottery of Group 5 consists of a majority of Type VI and stray specimens of Type VII: White Painted VI, White Painted VI—VII, Stroke Polished II (VII), Plain White VI—VII, and a number of Black Glazed Greek sherds. This group of pottery is represented below the uppermost floor of Room 64 and below the upper floor of Room 66.

These pottery groups form a chronological sequence, the beginning of the sequence being represented by Group 1 and the end by Group 5.

Group 1 which altogether consists of pottery of late Type V can accordingly be assigned to the latest part of Cypro-Archaic II. It is evident that the parts of the palace, where this pottery is found below the floors, must belong to the 1st building period and we may therefore infer that the palace of that period was erected during the last stage of Cypro-Archaic II.

Group 2, containing a majority of pottery of Type VI, mixed with some specimens of Type V, dates consequently from the very beginning of Cypro-Classic I. This pottery group, as shown above, was found below the floors of the coherent complex of Rooms 41, 85—93; in the architectural analysis (p. 193) these rooms were assigned to the 2nd building period both on architectural grounds — the rooms were proved to be a later addition to the palace of the 1st period and earlier than subsequent rebuildings — and on ceramic evidence, with reference to the composition of the pottery types found below the floors of the rooms. The bearing of the ceramic evidence can now be judged: the pottery of Group 2 found below the floors of these rooms is, on the one hand, later than that found below the floors of the 1st building period (Group 1) and, on the other hand, earlier than the pottery groups found below the floors of the subsequent rebuildings (Groups 3 and 4). The ceramic evidence is thus in agreement with the architectural facts and assigns the 2nd building period to the very beginning of Cypro-Classic I.

Pottery groups 3 and 4 were found below the floors of the subsequent rebuildings of the palace and are thus of decisive, chronological importance for the dating of the next, or 3rd building period. As shown above, these groups are not entirely uniform: Group 3 contains a numerical equilibrium of potsherds of Types V and VI while the sherds of Type VI are in majority in Group 4. This is explained by the different character of the strata where these groups were found: Group 3 was found in culture strata accumulated during Periods 1—2 (between the lower and upper floors of Rooms 62—63, 75 + 77 and between the lowermost and middle floors of Room 64), while Group 4 was found in levelling debris below the floors of the 3rd period. Group 3 thus represents the pottery existing during Periods 1—2 and contains therefore a greater amount of the earlier Type V, while Group 4 represents the pottery existing at the beginning of the 3rd period. The considerable quantity of Type V even within this latter group assigns the beginning of the 3rd building period to a short time before the middle of Cypro-Classic I.

The pottery group 4, as shown above, was found below the floors of some of the rooms

which can be assigned to the last, i. e., 4th building period of the palace. As this group contains a majority of potsherds of Type VI and some stray sherds of Type VII, the 4th building period can be assigned to the beginning of Cypro-Classic II.

These chronological conclusions are supported by the supplementary evidence given by the discovery of some vases below the repaired floor of Room 30, in the well-shaped cistern in Room 35, in Layer 5 of the filling in the cavity below the floor of Room 13, below the floors of the S. E. courtyard (Room 83), Room 66, and in Room 132; further, by the great number of vases found on the floors, or in the debris above the floors of the different rooms of the palace, and the hoard of silver coins found in the gold and silver treasure deposited in the terracotta jar below the staircase in Room 59.

The vases below the repaired floor of Room 30 (Nos. 551—558) are all of Type VI, which shows that this floor was repaired in the 3rd building period (cf. p. 199).

In the well-shaped cistern in Room 35 a Plain White VI jug (No. 563) was found; in Layer 5 of the filling below the floor of Room 13 a White Grounded Attic lekythos (No 453) from about 460 B. C.; below the floor of the S. E. courtyard fragments of a Red Figured amphora (No. 9) from about the same time; below the lower floor of Room 66 a Plain White VI bowl (No. 346) and a Black Glazed bowl (No. 325 a); below the floor of Room 132 a Plain White VI bowl (No. 540). As the cistern was filled in at the beginning of the 3rd building period and the floors below which the vases were found were laid at the same time, we see that these finds are entirely in agreement with the chronological evidence of the potsherds.

As can be seen from the classification of the pottery, the number of vases found on or above the floors of the palace rooms consist of a majority of Type VI and a few specimens of Type VII. Pottery is fragile and it is therefore evident that the vases in question are representatives of the ceramic material existing during the last period of the palace and they provide us therefore with a means of dating this period and the destruction of the palace. As was shown above, the potsherds found below the floors of the 4th building period consist of a majority of Type VI and stray specimens of Type VII assigning this period a date of the very beginning of Cypro-Classic II. The vases referred to above form a ceramic group consisting of a majority of Type VI, White Painted VI, Bichrome Red III (VI), and Plain White VI, and a minority of Type VII, represented by Plain White VII. The proportion between the two types has, however, changed somewhat, so that there is a larger quantity of Type VII than in the group of potsherds below the floors of the 4th period: of 34 vases found on the floors of the palace, 26 specimens are of Type VI and 8 of Type VII. This combination of pottery types indicate a somewhat later stage within Cypro-Classic II than that represented by the potsherds below the floors, but the still small number of vases of Type VII does not admit of a later date than about the end of the first quarter of Cypro-Classic II. This is, therefore, the approximate date of the destruction of the palace as fixed by the ceramic evidence.

Finally, we have to consider the chronological evidence of the coins found in the gold and silver treasure (cf. p. 278). The gold darics of Artaxerxes I give the date 464—424 B. C.

The Marion and Paphos coins can be assigned to the later part of the 5th Century B. C. The single coins from Idalion, Amathus, and Aspendus can be assigned to the same century; the Idalion coin seems to be the earliest as it must be dated before about 470 B. C., the approximate date of the incorporation of Idalion into the kingdom of Kition (cf. Vol. II, p. 625). Of the Kition coins, 9 specimens can be assigned to Azbaal, 43 specimens to Baalmelek II, and 17 specimens to Demonikos. The years for the reigns of Azbaal and Baalmelek II are not exactly known. Azbaal is usually supposed to have reigned between c. 445—425 B. C.¹² but this seems to be too late a date for the following reason. An inscription from Idalion¹³ is dated "in the third year of the reign of Baal [melek, king of Ki] tion and of Idalion, son of the king Azbaal king of Kition and Idalion, son of the king Baalmelek, king of Kition". Baalmelek, the father of Azbaal, was thus king of Kition while Azbaal was king of Idalion as well. Consequently the capture of Idalion, which on the evidence of our excavations there can be assigned to c. 470 B. C. (cf. Vol. II, p. 625), falls within the reign of Azbaal which cannot therefore have begun later than c. 470 B. C. The reign of Baalmelek II is supposed to have come to an end at c. 400 B. C.¹⁴ It seems most probable that Demonikos reigned in Kition for the short period 388—387 B. C., when Chabrias controlled the politics of Cyprus.¹⁵ The majority of the coins can thus be assigned to the later part of the 5th Century B. C. and none can be dated later than 387 B. C., i. e., not later than the end of the first quarter of Cypro-Classic II (cf. Vol. IV), when the destruction of the palace took place according to the ceramic evidence stated above.

Summing up the chronological results we thus obtain the following dates:—

1st and 2nd building periods: from the last stage of Cypro-Archaic II to shortly before the middle of Cypro-Classic I, i. e., from c. 500 B. C. to c. 450—440 B. C.

3rd and 4th building periods: from shortly before the middle of Cypro-Classic I to the end of the first quarter of Cypro-Classic II, i. e., from c. 450—440 to c. 380 B. C.

These dates obtained from the purely archaeological material tally with deductions derived from a combination of the archaeological material with certain historical events during the 5th and early 4th Century B. C. In the *American Journal of Archaeology*, XXXVII, 1933, pp. 593 ff., I have already treated this subject and as I have hardly anything to add, or alter in the discussion given there, I now quote what I have written in that paper.

It is well known that the Cypriotes revolted against Persia in 498 B. C. The revolt was a failure. Aristokypros, king of Soli, fell in the battle, but of all the Cypriote rebels this city seems to have made the most strenuous resistance: the citizens defended themselves behind the walls of their capital but after a five months' siege had to surrender. It is worthy of notice that this happened about the time when, according to archaeological evidence, the palace at Vouni began to be built. We have seen that the palace is the monumental centre of a settlement extending from the top of the hill down the slopes towards the sea, and was defended by a massive fortification wall (cf. above, pp. 78 ff.). It was a stronghold from which the whole maritime plain around Soli could be controlled. It is not very probable, that a dynast of Soli would have been allowed to build this strongly defended palace, be-

VOUNI

Reconstructed sketch of the
palace as in period 1.

PLAN XXVI

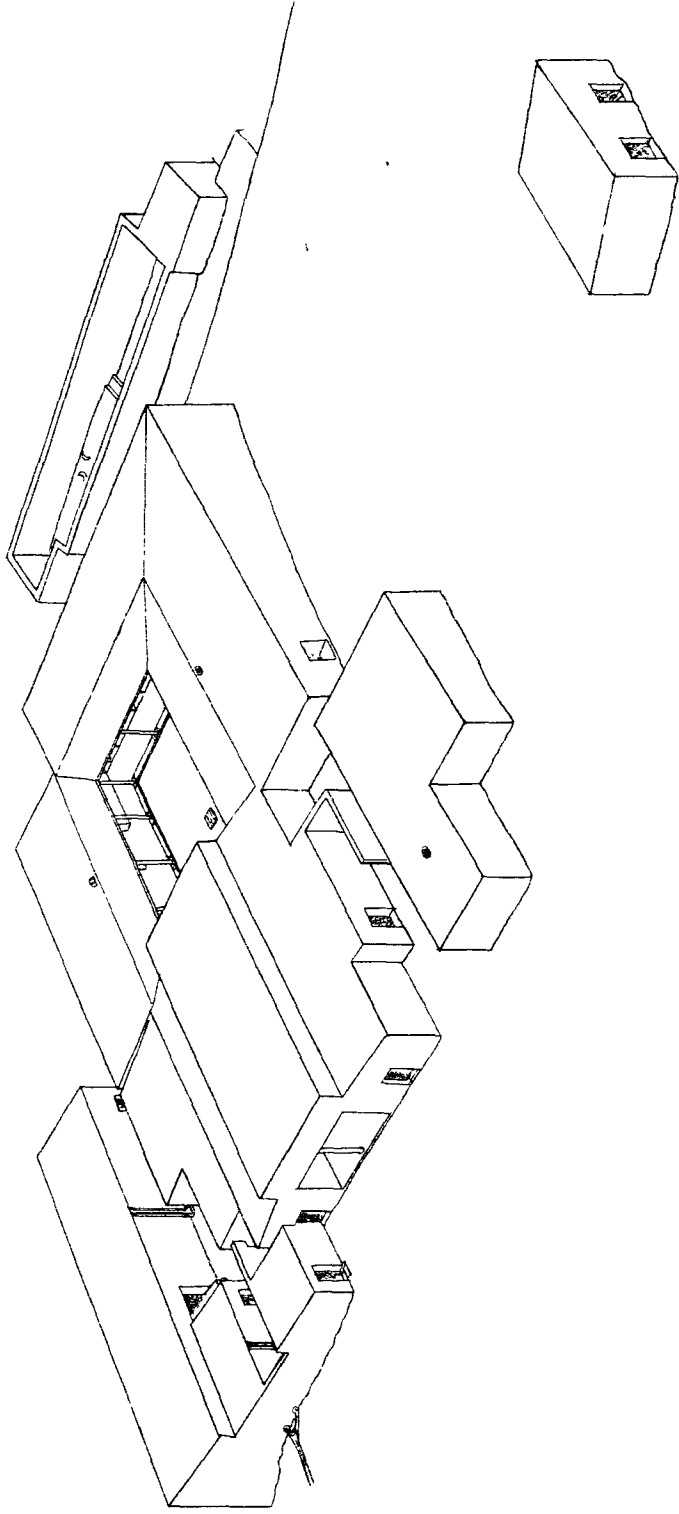

VOUNI

Reconstructed sketch of the
palace as in period 4.

PLAN XXVII

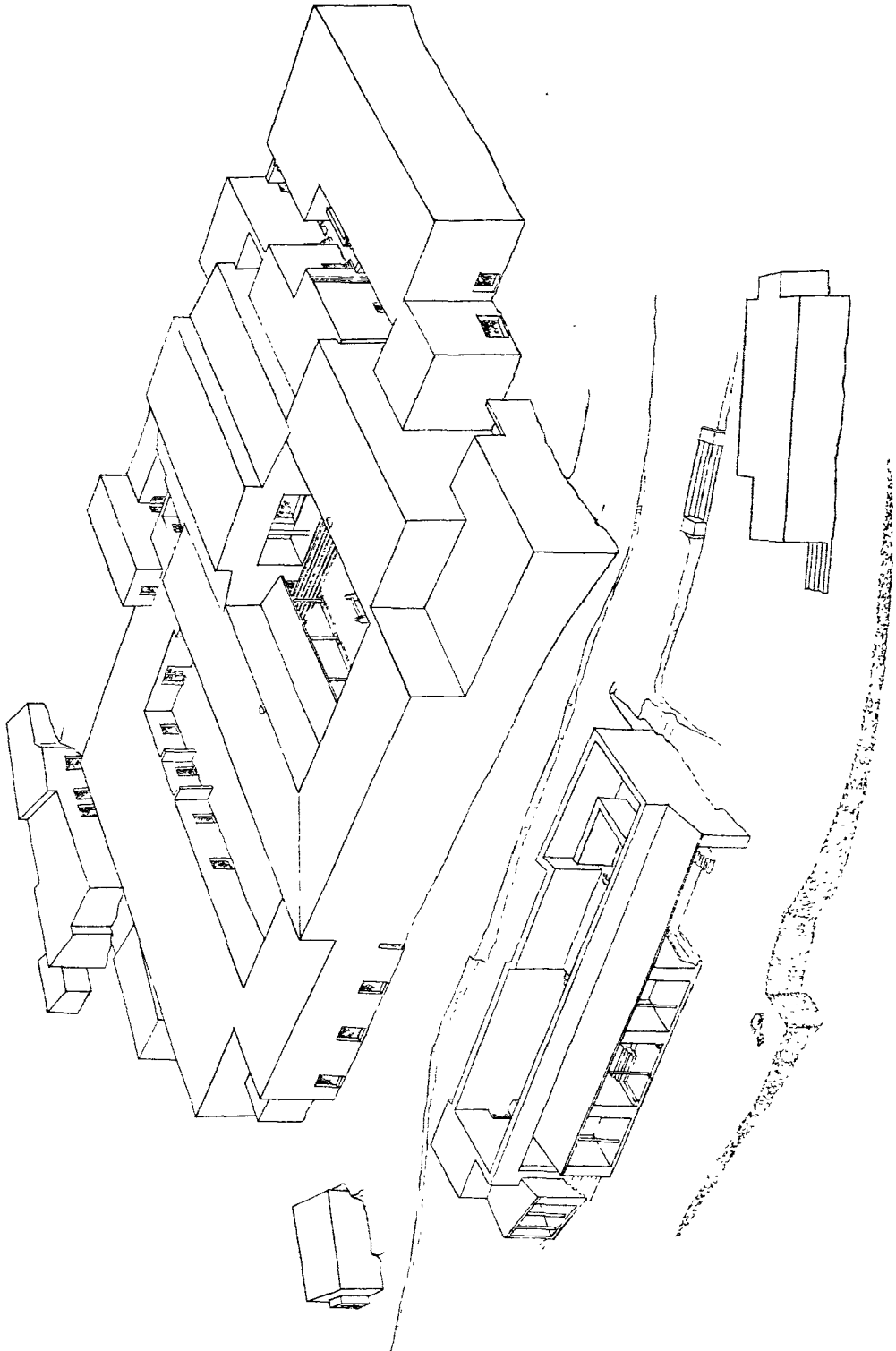

cause Soli had ceased to be an independent state, being again in the hands of the Persians and tributary to Persia. Who then built the palace? I think we may find an answer to this question if we consider something that happened about fifty years later, or, more exactly, in 449 B. C. when Kimon made his expedition to Cyprus. We know that he attacked two of its cities: Kition and Marion, and that the latter town was captured. As the aim of his Cyprian expedition was to liberate the island from the Persian dominion, it was natural that he should attack the Phoenician city of Kition which was a centre of Persian power in Cyprus. But why did he attack Marion? *A priori*, it may be assumed because Marion was another Persian centre. Had the town been in the hands of the Cypriote Greeks it would not have been necessary to attack it: it would have hurried to open its gates. It seems therefore, that a medophile dynast ruled Marion at the time of Kimon's expedition.

Consequently, we have to take into consideration the following facts and indications as regards the question, who built the palace at Vouni. The palace was built, approximately, contemporary with the capture of Soli by the Persians in 498 B. C. As a result of this capitulation, Soli ceased to be a formally independent state; it is then improbable that the fortified palace at Vouni would have been built by a king of that city; on the other hand, there are indications that a medophile dynasty ruled Marion, the neighbouring kingdom to Soli to the South, during the earlier part of the 5th Century B. C. Furthermore, the architectural style of the first palace is Oriental in character: it is built in old-Cypriote, native style (cf. *Corolla archaeologica*, Acta Instituti Romani Regni Sueciae, II, 1932, pp. 155 ff.; *A. J. A.*, XXXVII, 1933, p. 394; Vol. IV of this publication) and thus it was a non-Hellenic minded king who built it.

In an endeavour to connect the erection of the fortified Vouni palace with the political conditions, we thus find that of the two kingdoms bounding the district of Vouni, Soli is excluded in this respect, while the indications are in favour of the supposition that a medophile dynast of the neighbouring kingdom of Marion was allowed, or even ordered by the Persians, to build the palace, in order to hold in check the rebellious, anti-Persian Soli.

When Kimon had captured Marion, the medophile dynast was, of course, dethroned and a new, anti-Persian king of the Greek national party in Cyprus took his place; that a dynasty from Marion resided in Vouni during the latter part of the 5th Century B. C. is corroborated by the composition of the coins found in the gold and silver treasure of the palace. Among these coins there are none from Soli. Coins from Soli do not exist from the 5th Century B. C. and we do not know of any kings of this city of that period — another indication that Soli ceased to be, even formally, an independent kingdom after the failure of the revolt. The majority of the coins, on the other hand, are from Marion, viz. 150 of the 248 coins. On the evidence of these coins, we know the names of two kings of this new, anti-Persian dynasty in Marion, viz. Stasioikos and his successor Timocharis.

Now it is to be observed that Kimon's expedition is approximately contemporary with the 3rd building period of the palace which on archaeological grounds has been assigned to about 450—440 B. C. It is then to be assumed that the new king, reinstated by Kimon,

was the one who rebuilt the palace. This hellenophile dynast apparently wished to rebuild it in accordance with Greek architectural principles, by the incorporation of Hellenic elements. This scheme proved to be a very simple one to carry out: a megaron-shaped main room was formed in the tripartite complex of the state apartments simply by closing the entrance hall with a transverse wall (cf. *Corolla archaeologica*, pp. 150, 169 ff.; *A. J. A.* XXXVII, 1933, p. 394; Vol. IV of this publication).

This hellenophile dynasty ruled Marion and resided in Vouni during the latter part of the 5th Century B. C. At the beginning of the 4th Century B. C., about 380 B. C., the palace was destroyed by fire and not rebuilt, as shown above. Was it destroyed by an accident or by force? The fact that the gold and silver treasure, hidden in a terracotta jar beneath the staircase of Rooms 59—60, was not removed after the destruction of the palace is against an accidental, and in favour of a violent destruction: if the palace had been destroyed by an accidental conflagration, one would have at least expected the treasure to have been removed after the destruction, since its place must have been known to the inhabitants. The next question is: who destroyed the palace? It is a remarkable fact that while the building of the palace coincides with the subjugation of Soli, its destruction coincides with the political resurrection of that city. From the 4th century B. C. coins from Soli occur again, and we know the names of some of its kings: Stasias, Stasikrates, and a second Stasias, son of Stasikrates. In 391 0 B. C. we hear of Soli in connexion with Euagoras' attempts to extend his rule over the whole of Cyprus. Kition, Amathus, and Soli asked Persia for help against Euagoras. By its recognition of the supremacy of Persia, Soli had thus regained its lost political power. The rôles had changed: while in 499 8 B. C., Soli fought against Persia and a medophile dynasty ruled Marion after that date, there was now a hellenophile dynasty in Marion, and Soli was in political alliance with Persia. Searching then for the enemy who destroyed the palace of the Marion kings at Vouni, we find him in Soli. The fortified palace of Vouni in the hands of the Marion kings was an unbearable threat against Soli, and it was necessary for the revived state to annihilate it. The violent destruction of the palace shows that this succeeded.

These historical connexions and the deductions based thereon are of course hypothetical, but there are important indications in their favour: they give a natural and coherent account of the architectural style and history of the palace, the differences in style between the first and second palaces; further, it explains the coincidence of the erection of the first palace with the subjugation of Soli, and its destruction with the renaissance of the power of the same state. Finally, these historical events tally in a remarkable way with the dates of the history of the palace, based on archaeological evidence and this latter is thus supported by the literary indications.

When the chronology of the palace architecture has thus been fixed, there remains the chronology of the finds.

The pottery has already been dated above, p. 285.

For the chronology of the sculptures we have to begin with these two fixed points: Style I which is typologically the earliest cannot be dated earlier than shortly after 500 B. C.

and Style IV which is typologically the latest cannot be later than the beginning of the 4th Century B. C. Style I is represented by a few specimens only in comparison with the great number of sculptures of Styles II and III, and it is therefore justifiable to infer that Style I lasted a much shorter time than the two others. Style IV, which is only represented by two specimens in stone and one in terracotta, must have begun only just before the destruction of the palace, i. e., about 390—380 B. C. Style I, as will be shown in Vol. IV, represents the end phase of the Cypro-Achaic style with strong East-Greek influence. The fact that it is represented only by a few specimens in Vouni indicates that it came to an end a short time after the erection of the palace and from a comparison with the corresponding Greek sculptures, we may infer that it cannot be dated later than 490—480 B. C., as will be shown in Vol. IV.

The time from 490—480 B. C. to 390—380 B. C. is thus reserved for Styles II and III. Style II, as shown above, p. 265, is a direct continuation of Style I and its earliest sculptures still show influence from the latest Ionian-Greek Archaic art, while in Style III the Archaic forms are more and more stereotyped and degenerate. There are no indications that the one of these styles lasted much longer than the other, but, on the other hand, it seems likely that Style III lasted somewhat longer than Style II, since a decadent style often shows tendencies to be more long-lived than a vigorous one. If, therefore, we suggest 450—440 B. C. as the limit of time between the two styles, we cannot be far wrong. Style II would thus come to an end and Style III begin approximately contemporaneously with the 3rd building period of the palace. Moreover, the sculptures which can be stratigraphically determined, i. e., those found in Room 93 below the debris with which the room had been filled in and below the floors of Rooms 66 and 69, confirm the date suggested. Room 93 was filled in at the beginning of Period 3, as shown p. 194. The head No. 262 found below the filling can be assigned to Style II B. Layer 4 of Rooms 66 and 69 (cf. Section XXVII, p. 186) dates from before Period 3, as shown above, p. 282. The two specimens of Cypriote sculpture (Nos. 335 + 342 and 345) found in this layer and assignable to a definite style, belong to Style II, and none of the Greek terracotta figurines (Nos. 321, 322, 332, 333, 390) discovered in the same layer is later than 450 B. C. Layer 3 of Rooms 66 and 69, on the other hand, was thrown in as a substructure for the floor of Period 4, as shown above, p. 197. The only specimen of Cypriote sculpture (No. 378) found in this layer and assignable to a definite style, belongs to Style III B.

The moulded, Greek figurines can be dated in accordance with the Greek chronology. Only the following specimens, which were found below the floors of the palace, can be dated supplementarily on stratigraphical evidence: No. 539, found below the floor of Room 132, and Nos. 321, 322, 332, 333, 390, found below the lower floor of Room 66, can be assigned to a date before Period 3; No. 339, found below the upper floor of Room 66, can be assigned to a date before Period 4.

Of the idols, animal figures, and fragments which cannot be assigned to any style of sculpture, only the specimens found below the floors of the rooms can be dated within exact chronological limits. For this reason, No. 258, found below the floor-level of the S. E. court,

No. 456, found in Layer 5 of the filling below the floor in Room 13, No. 561, found in the well-cistern in Room 35, and Nos. 318, 320, 323, 329, 330, 331, 334, 340, 341, 368, 372, 373, 375, 376, 381, 383, 386, which were found below the lower floor of Room 66, can be assigned to a date before Period 3; Nos. 379, 396—397, 398, 399, 400, 406, 451, which were found below the floor of Room 69, date from before Period 4.

The majority of the minor objects of iron, bronze, lead, silver, gold, terracotta, faience, and stone, which were found on the floors of the rooms or in the debris covering the floors, cannot with certainty be assigned to any particular period within the time during which the palace was in existence, with the exception of the coins which are dateable by themselves, and were to a great extent struck by kings whose reigns can be at least approximately determined (cf. *Classification of Finds*, p. 277). As shown above, p. 285, the majority of the pottery vases, found on or above the floors, can be considered to date from not very long before the destruction of the palace on account of the fragility of the pottery. A good many of the minor objects mentioned above, on the other hand, are of more durable material so that they may have been in use for a fairly long time. We may assume, however, that most of these finds date from the later part of the 5th Century B. C. or the beginning of the 4th Century B. C. A more exact dating is only possible as regards a few minor objects found below the floors of some of the rooms, as shown in *Conditions of Finds*, pp. 278 ff. These objects are the earring No. 418 found in Layer 6 of the debris below the floor of Room 13 and therefore dating from the time of the erection of the first palace; the iron arrow-heads No. 454 and the alabastra Nos. 457 and 458 found in Layer 5 of the same debris, which assigns them to Periods 1—2; the bronze arrow-heads Nos. 277 and 278 and the socket-shaped mounting No. 276 found in the disturbed filling below the floor of Room 39 and therefore dating before Period 2; the fragments of a bronze mounting No. 11 and the loom-weight No. 10 found in the filling below the floor-level of the S. E. courtyard and therefore dating from before Period 3; the bronze arrow-head No. 354 found below the floor-level of Room 8 and therefore dating from before Period 3; the bronze jug 566 and the terracotta lamp No. 565 found in the well of Room 35 and therefore dating from before Period 3; the bronze loop No. 384, the bronze handle No. 319, the bronze mountings and fragments Nos. 343, 344, 377, and 389, the gold string No. 325 b, the gold plaque No. 336, the terracotta lid No. 382, the faience bead No. 387, fragments of the faience bottle No. 324, the glass bead No. 385, the lump of cobalt No. 374 which were all found below the lower floor of Room 66 and therefore date from before Period 3; the iron arrow-head No. 327, the bronze arrow-heads Nos. 370 and 371, the bronze nails Nos. 326 and 369, the glass bead No. 328 which were found below the upper floor of Room 66 and therefore date from before Period 4; the iron nails Nos. 404 and 405, the bronze nail No. 403, the bronze mountings Nos. 402 and 407, the fragment of spindle-whorl No. 401 which were found below the floor of Room 69 and therefore date from before Period 4; finally, the bronze incense-burner No. 537, the bronze shovel No. 541, the bronze mountings and fragments Nos. 542 and 543, and the gold leaf No. 538 which were found below the floor of Room 132 and therefore date from before Period 3.

E. G.



Fig. 158. Vouni. Loures. Trial excavation D.
Column base *in situ*.



Fig. 159. Paradiotissa. The temple seen from
the East.

Loures.

There are many traces of ancient buildings on the N. slope of the hill. According to the peasants, too, many antiquities, such as pieces of sculptures, metal objects, etc. would seem to have been found here. The slope is very steep, and the houses must have been placed on narrow terraces running from E. to W. There is no place for structures covering a large area. A great number of cisterns were either entirely accessible, or known to the peasants. Other cavities in the rock, which are of uncertain purpose, are visible in many spots.

Excavations were carried out in two localities in order to trace a stratification corresponding to that in the palace. Two trenches were opened not far from the Soli gate through the rampart at D on the Field Plan VII; the other was situated along the same terrace but further to the W. (E). On both occasions houses of considerable size were trenched over.

The trench at D was about 20 m. long and 2 m. wide. A large building was trenched over. This was of a similar construction as the palace. The rock had been used in a similar way so that rooms were partly excavated in the sloping rock. The same kind of hard, well-preserved cement was used both for the floors of the new building and for the large central court of the palace, and the construction of the walls (ashlar-walls) had been used in both cases. Two stories were recognized, one having a 7.40 m. wide floor, situated 3.00 m. above the lower floor, which was followed in the trench for a distance of 3.30 m. On the upper floor a stone stylobate was sunk down in the same way as in the palace court (Room 47). One of the column-bases was preserved *in situ* (Fig. 158). It consists of a torus on a rectangular base, the whole sculptured of a single block of stone. Some further fragments of similar bases were found farther down in the trench. The lower floor was of the same character

as the floors of the western store-rooms of the palace (Rooms 10--14, cf. below). The rock had been roughly levelled, and the surface was covered with a thin layer of cement. Rows of cavities were observed like those in the palace rooms mentioned. Evidently they too, had been used for storing *pithoi*, because large fragments of the vases were found on the floor. No other finds were made in this locality.

The second trench, at E, uncovered a part of a similar house, though of still larger size. Its extent, visible in the trench, was at least 25 m. Three rooms were trenched over, the uppermost with more than 4 m. high walls. The second room is about 8 m. wide, and seems to have been a store-room. The width of the third room cannot be ascertained. This contained some finds lying on the floor (Nos. 545—550, cf. p. 260).

The earth layers which filled these rooms were rather homogeneous, consisting of grey earth with pieces of mud-bricks. The layer with the finds, however, was dark in colour and mixed with ash and charcoal.

The excavations in Loures were never continued, and the structures therefore still remain to be excavated. No doubt the houses were connected with the palace in some way, and it may be right to assume that they were destroyed contemporaneously with the palace. In any case, the excavations at Loures had not brought to light anything which should be dated to a period earlier than the palace or later than the latest finds in it.

A. W.

Paradisotissa

TOPOGRAPHY

The situation of the temple described below is rather remarkable. The site which is called Paradisotissa is situated about 1.5 km. N.-W. of the summit of Vouni, in a small valley. On three sides this is surrounded by high and steep hills or mountain ridges, but on the fourth side it is open towards the sea. The bottom of the valley, however, is not on the same level as the shore but on a terrace about 20 m. above sea-level. From this bottom, which is cultivated and hidden by an exceptionally rich vegetation, the valley rises like a Greek theatre. From below nothing can be seen behind the ranges around the valley, and on the other hand one has to approach very near the edge of the valley to be able to look into it. In many cases the sides are absolutely vertical around the upper parts, whereas the lower slopes are provided with narrow strips of cultivated, artificial terraces. Curiously enough, the valley was watered by two parallel rills which come from the rocks above. In our days the upper parts of the rills are dry and the spring with plenty of excellent water is now rising quite near the bottom of the valley, where the ruins of a small Panajia Paradisotissa still can be traced. Between the rills is a small ridge with a narrow triangular promontory in the very centre of the valley. Here the temple was situated.

But there are also other ancient remains within the valley of Paradisotissa. Many rock-



Fig. 160. The valley of Paradisotissa from the sea.

tombs similar to those on the N. slope of Vouni (cf. p. 81) are visible in the upper parts of the slope. Their association with the necropolis at Korakas cannot be ascertained, as none of the tombs was examined. There seems also to have been an ancient copper mine on the slope. Close to the western rill in the valley, rather high up, a mining shaft begins. It leads horizontally straight into the rock and was followed for more than 50 m. but its termination was not reached. The explanation of the hole remains uncertain. It is called by the peasants Ajotripa, certainly on account of the green marks of aerugo on the sides and on the rock below. There is no slag or other traces of mining in the vicinity.

On the eastern slope an ancient quarry can be seen, and it is more than likely that some of the stones in the palace of Vouni were quarried here. This holds good as to the limestone used in Walls 1—4 in the palace (cf. p. 116). The same material seems to have been used for the sculptures of very soft limestone (cf. Appendix VI).

The excavations were finished in a few days in June, 1930. Only the temple on the ridge between the rills was examined. According to the peasants there was a tradition that a large statue long ago had been discovered on this spot, and this might have been true, as fragments of other, though minor sculptures, were found on the ground when the excavations were begun.

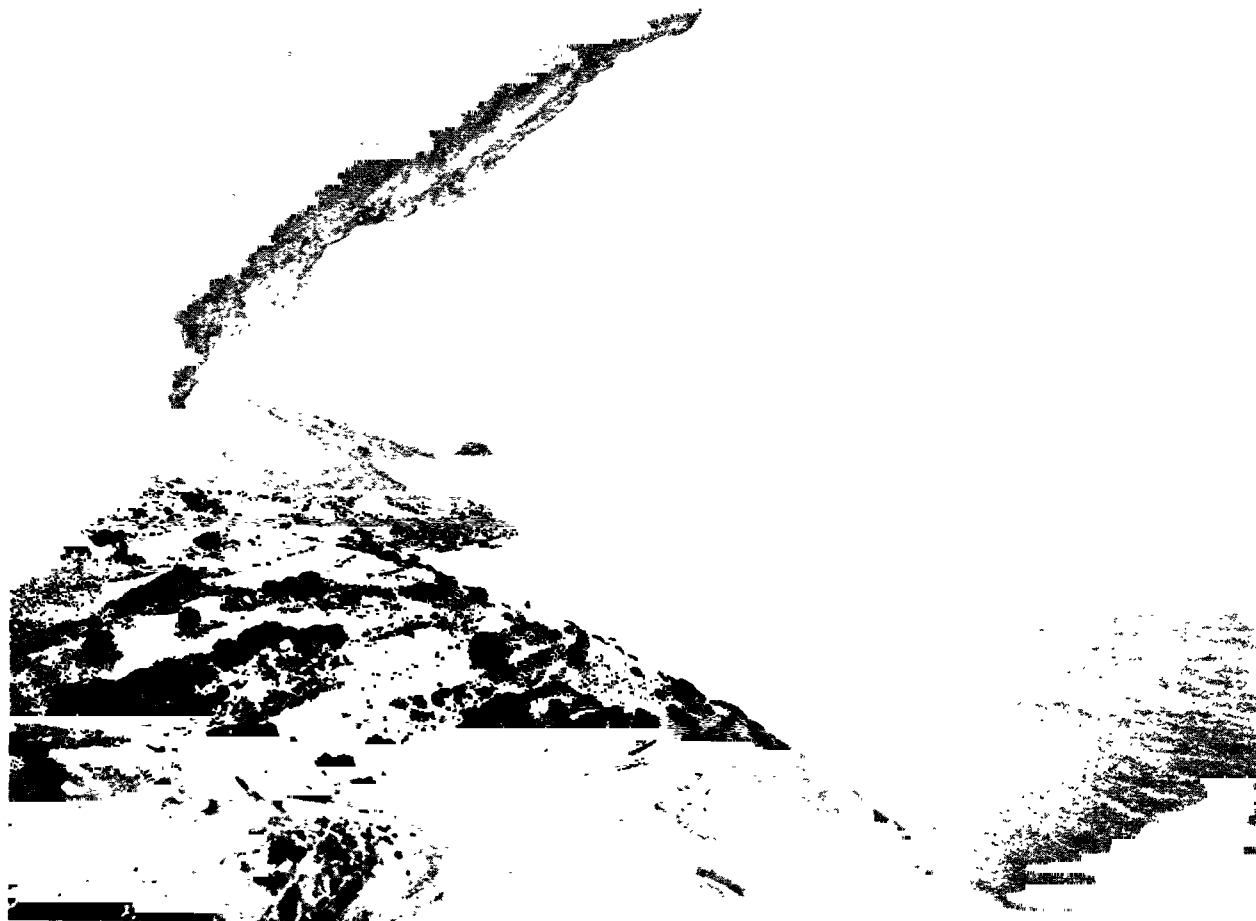

Fig. 161. The valley of Paradisotissa from the South.

ARCHITECTURAL ELEMENTS (PLAN XXVIII; FIG. 159)

W a l l s.

Wall 1.

Width: 0.30—0.60 m. Height: 0.55 m.

This wall constitutes the rear wall of the temple. It was built in order to make even the vertical rock behind it or to fill out its hollows. The wall founded on the rock-floor consists of different-sized rubble.

Wall 2.

Width: c. 0.75 m. Height: 0.33 m.

The temple is limited on the N. by this stout wall constructed of raised ashlars, making a kind of shell on the E. façade. The western side of the wall consists of rather irregular rubble. The west façade is partly destroyed and has evidently been strengthened by Wall 7.

Wall 3.

Width: 0.90 m. Height: 0.55 m.

This wall separates Rooms I and II. The greater part of the wall is destroyed, but as far as can be seen from the preserved remains, the wall originally was constructed with shells

of raised ashlar on either side of a core of fine rubble. It may be impossible to state whether there was an entrance through the wall or not. In about the middle there is a rather high piece of rock built into the wall.

Wall 4. Height: 0.55 m.

This wall, which once constituted the eastern boundary of the temple, is almost entirely destroyed. The western face of it, however, can still be ascertained in the shape of a line of gypsum. This disappears towards the N.

Wall 5. Width: 0.70 m. Height: 0.50 m.

This is preserved only in its western parts where it consists of irregular rubble, one block filling up the whole width of the wall. Possibly this stone marks the place for the jamb of a doorway. The stone close to it seems to be part of a threshold.

Wall 6. Width: 0.80 m. Height: 0.55 m.

This is a short piece of wall, which starts from the western parts of Wall 5, but not at a line with Wall 2. It is wide and solidly constructed of different-sized rubble. The N. portion of the wall is destroyed. Evidently the wall was bonded with Wall 5.

Wall 7. Width: 0.70 m. Height: 0.60 m.

To the W. of Wall 2 is another wall constructed close to its façade. This is constructed of coarse rubble. As far as can be seen this has been built in order to strengthen Wall 2. The N. portion of the wall is destroyed.

Floors.

Room I.

The floor in this room has entirely disappeared. Not the slightest trace of the original floor-level could be observed. The rock, however, has been levelled off roughly. Most likely the original floor was constructed on this very surface.

Room II.

Room II has its floor laid out on a somewhat lower level. It is comparatively well preserved, and consists of reddish, burnt clay, like some of the floors in the palace (e. g. Room 66) and in one of the treasuries of the temple of Athena (Room V). The floor is placed on a layer of light-grey earth.

Room III.

The floor in this room was of the same construction as the previous one. Only a minor part of it is preserved in the S.-W. corner.

STRATIFICATION

The stratification is very simple. Below the darkened surface layer (1) follows a layer of debris containing plenty of fragments of roofing-tiles and a few coarse potsherds. This layer (2) extended down to the bottom of the floors: in Room II there is also a third layer found on the very floor. This consisted of ash and charcoal (3). In Layer 3 only the bronze nails (No. 592) were found. All the other finds were made in Layer 2.

ARCHITECTURAL SYNTHESIS

It is seen that the isolated situation of the building, and its shape in general, indicate that it was a temple. The shape of the ground plan points to a Greek *templum in antis* as the most natural prototype for it. Certainly it must be explained as a very rustic, local imitation of the Greek type.

It is noted that the temple has not the usual orientation. The ante-room should have been facing towards the E. in accordance with most of the Greek temples of this kind. In consideration of the local conditions in this case, however, it is but natural that the façade points to the N. This is the direction towards the sea and the orientation of the whole valley. Provided the temple was placed on the same terrace, but in E.-W. orientation, the front would be facing a rock wall not more than 50 m. distant.

FINDS

- 1-584 See the Temple of Athena, and the Palace.
- 585 Fragment of a head of classical type with rounded chin; full cheeks; full lips with cut angles in the corners; straight nose with marked nostrils. Only r. lower side of head preserved. Height 11.0.
- 586 Fragment of a statuette, only upper l. part of shoulder and breast preserved. Small part of chiton visible with vertical folds; himation over l. shoulder and across body; marked borders and vertical folds. Traces of red on borders of himation. White limestone. Height 24.0.
587. Fragment of legs belonging to a statue, with l. leg advanced. Vertical, curved folds of the dress falls tight along legs. White limestone; worn. Length 30.0.
- 588 Lower part of statuette representing a woman sitting in a chair wearing himation with curved, vertical folds and chiton reaching down to feet with narrow, vertical folds. White limestone, worn. Height 13.0.
- 589 Bronze coin, indecipherable. Diam. 16.
- 590 Fragment of iron rod.
- 591 Fragment of iron rod.
- 592 Seventeen bronze nails with flat, circular heads; pointed ends, hooked. Length 4.6.
- 593 Coarse cooking-pot with round base, sloping shoulder; short neck; rim slightly out-turned; handles from rim to shoulder. Height 15.8.
594. Statuette of a lion, "couchant" on small base in r. profile with r. forepaw over the l.; head *en face* with open mouth; well marked mane. Hind part missing; surface of body obliterated; head much worn. White limestone. Length 10.5. Height 9.3.
595. Roughly circular disc of limestone with a small flat shaft. Traces of the working tool on both sides of disc. The disc may be an unfinished plate or bowl. Diam. 14.0.
596. Thick, rectangular plaque of bronze with a representation in high relief of a naked, female figure in frontal position with isolinear feet; vertical arms along sides of body; bracelet on either arm; wearing on head an Egyptian wig. Length 3.55. Width 1.35. Length of figurine 2.8. Width of figurine 0.95.
597. Terracotta antefix in shape of a palmette growing from a plain base; a rhombic field at centre of base. Top missing. Palmette and sides light red painted; black back-ground. Height 19.0.
598. Sheet of lead of a roughly rectangular shape. Length 10.5.

Architectural plan

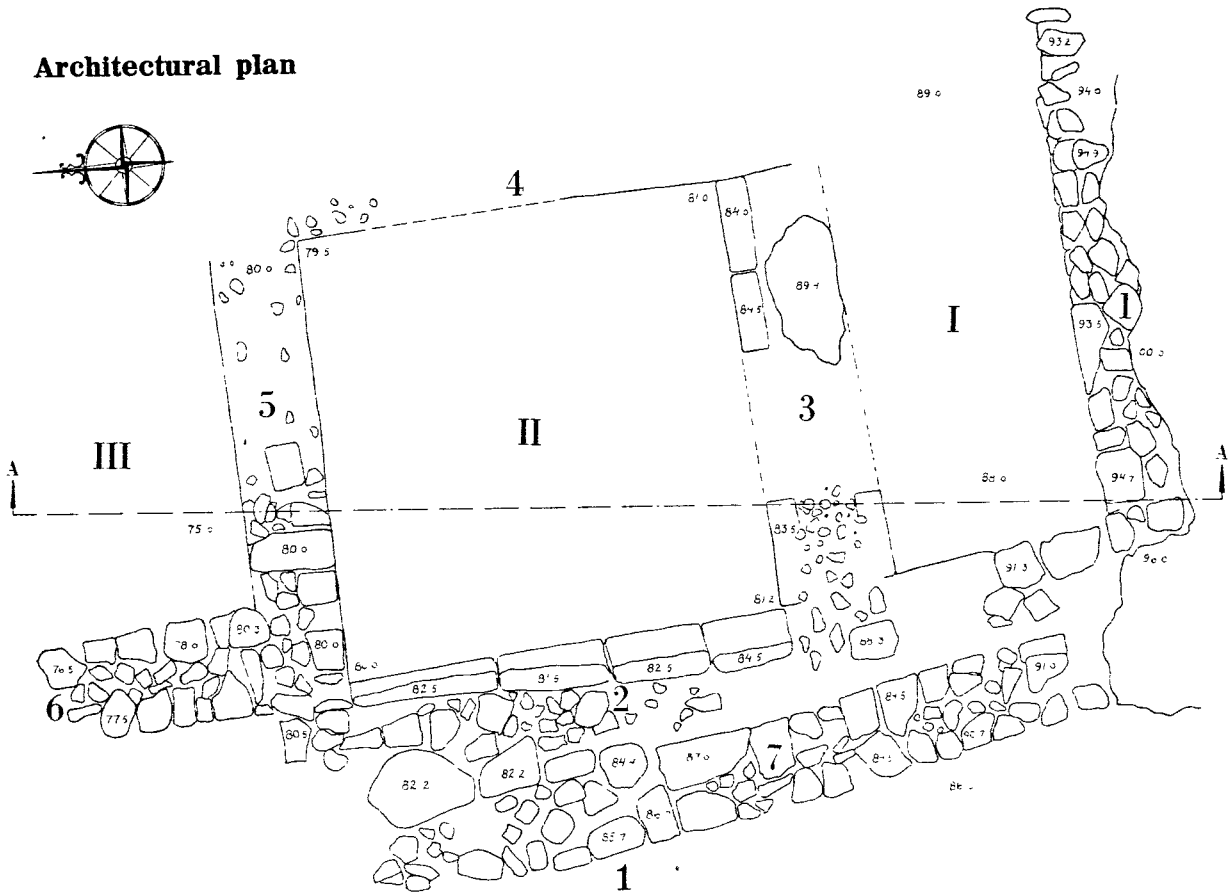

Section

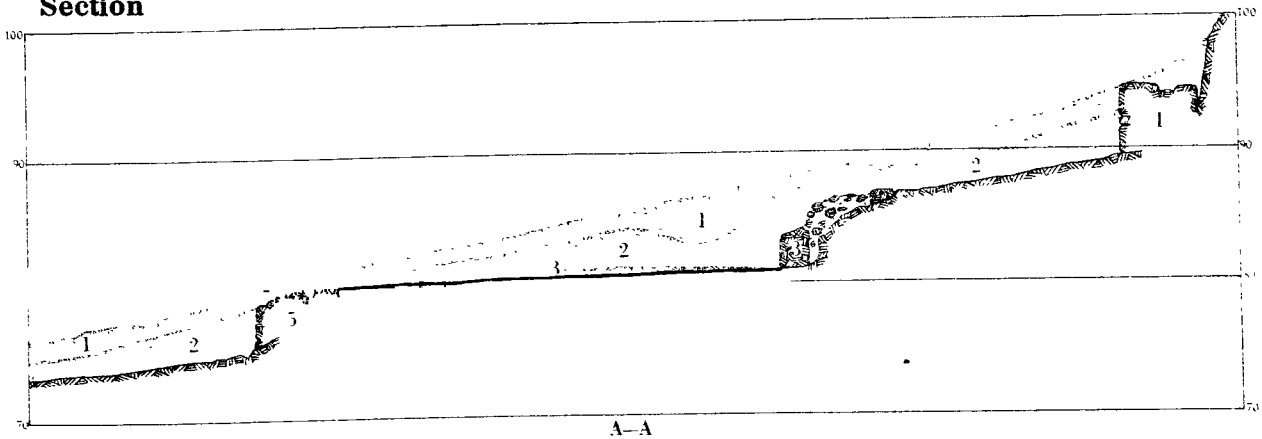

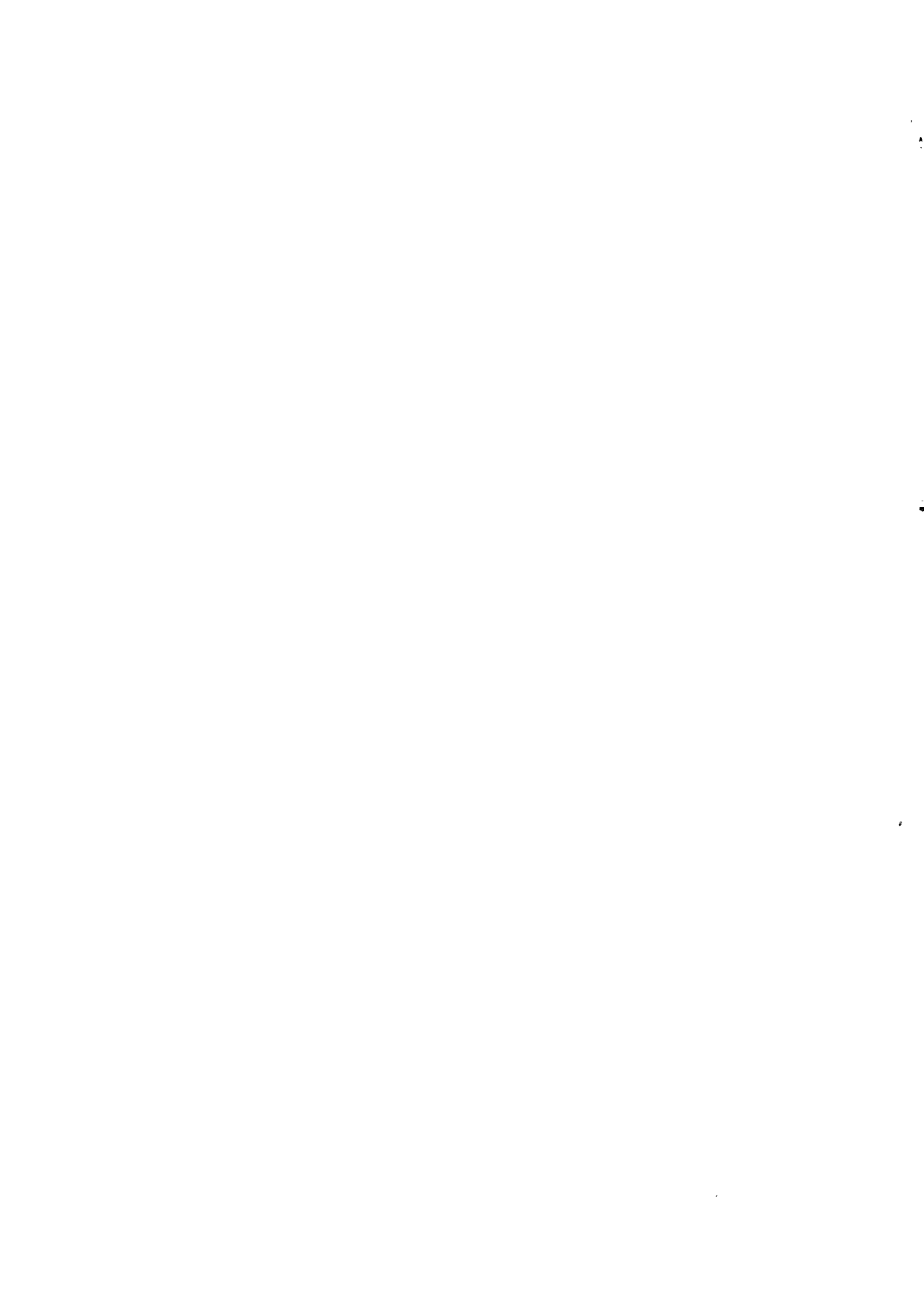

CLASSIFICATION OF FINDS

Sculptures (Pl. XCVIII).

All the sculptures were of limestone but as to the styles they show distinct varieties. They are here classified in accordance with the much larger sculptural material from Vouni and Mersinaki. The sculpture styles are there characterized (cf. below) and, therefore, it is not necessary to describe the styles, as so few pieces were actually found.

The fragment of the large statue (No. 587) is ascribed to Style II of the Vouni series, and the small statuette (No. 588) is referred to this comparatively early period. The rest of the sculptures (Nos. 585, 586, and 594), are all ascribed to a style which is called IV B. Sculptures of this kind did not exist at Vouni. There can be no doubt that they constitute a direct continuation of the Vouni series and of its latest style.

Pottery.

Only one rather coarse cooking-pot was found (No. 593).

Iron.

The two iron rods are so much corroded that no definite type could be distinguished (Nos. 590, 591).

Lead.

The piece of lead (No. 598) is thin and roughly rectangular in shape.

*Bronze.**Nail.*

The 17 bronze nails described as No. 592 are all of the same type, with thin, short shank and large, flat head.

Plaque (Pl. XCVIII).

The plaque with a small figure in relief (No. 596) may be explained as some votive offering. It is comparatively thick and seems to be rather rare.

*Terracotta.**Antefix* (Pl. XCVIII).

The antefix (No. 597) is of similar shape to those found at Vouni, with a palmette in relief.

Stone.

The meaning of the limestone disc (No. 595) seems to be uncertain. Possibly it is unfinished and was intended to be applied to some sculpture.

CONDITIONS OF FINDS

The finds were made on the floors of Rooms I—II, and just outside Wall 7. Nothing can be determined as to the position of the objects. Evidently they had been scattered about, and were found removed from their original places. The 17 bronze nails (No. 592) evidently belonged to a box or some other minor object which had decayed on the floor.

CHRONOLOGY

Only few fixed points for the chronology can be ascertained. Unfortunately the coin (No. 589) could not be deciphered. The pottery fragments were all of a very coarse ware, which could hardly be referred to any period within definite limits. Also as to the other minor objects, one ought to be chary in dating them. The sculptures certainly offer the best evidence of the time in which the temple was used. The earliest of the sculpture fragments seems to be the fragment of the large statue (No. 587). This may well be dated as early as to Style II of the Vouni series. Its resemblance to the *kore* statue of Vouni (No. 16, etc.) is evident. No. 588 must be ascribed to about the same period. In comparison with the sculptures mentioned above, the rest represents a much later epoch. The head, No. 585, has certainly no counterpart among the Vouni finds. It represents a somewhat later stage than the latest Vouni sculptures, a style which will be called Style IV B. This may be dated to the middle of the 4th century. The fragment (No. 586), and the stone lion (No. 594) are ascribed to this period, too. The antefix is of the same general type as that which was found at the temple of Athena on the summit of Vouni (No. 201).

In so far as any conclusions can be drawn from these conditions, it seems reasonable to assume that the temple was constructed already as early as during the first period for the palace of Vouni, or during the first half of the 5th century. Apparently it was not destroyed contemporaneously with the palace, but somewhat later. This tallies with the period in which the necropolis of Korakas was used. Most of the tombs excavated there represent a somewhat later period than the latest finds in the palace. Possibly there may be some connexion between the temple at Paradisotissa and the necropolis at Korakas in the vicinity.

A. W.

The necropolis at Korakas

About 400 m. W. of the foot of Vouni, there is a small ridge which terminates with a small rocky hill just above the valley of Paradisotissa. The sides of the ridge are partly cultivated and in the fields some pine-trees and charup-trees are growing. On this site the tombs were discovered, usually situated exceptionally far from each other. The tombs of the southern part of the necropolis are excavated in the very soft, dark *chavara* rock whereas for the northern tombs, on the slope of the small hill mentioned above, a much harder,

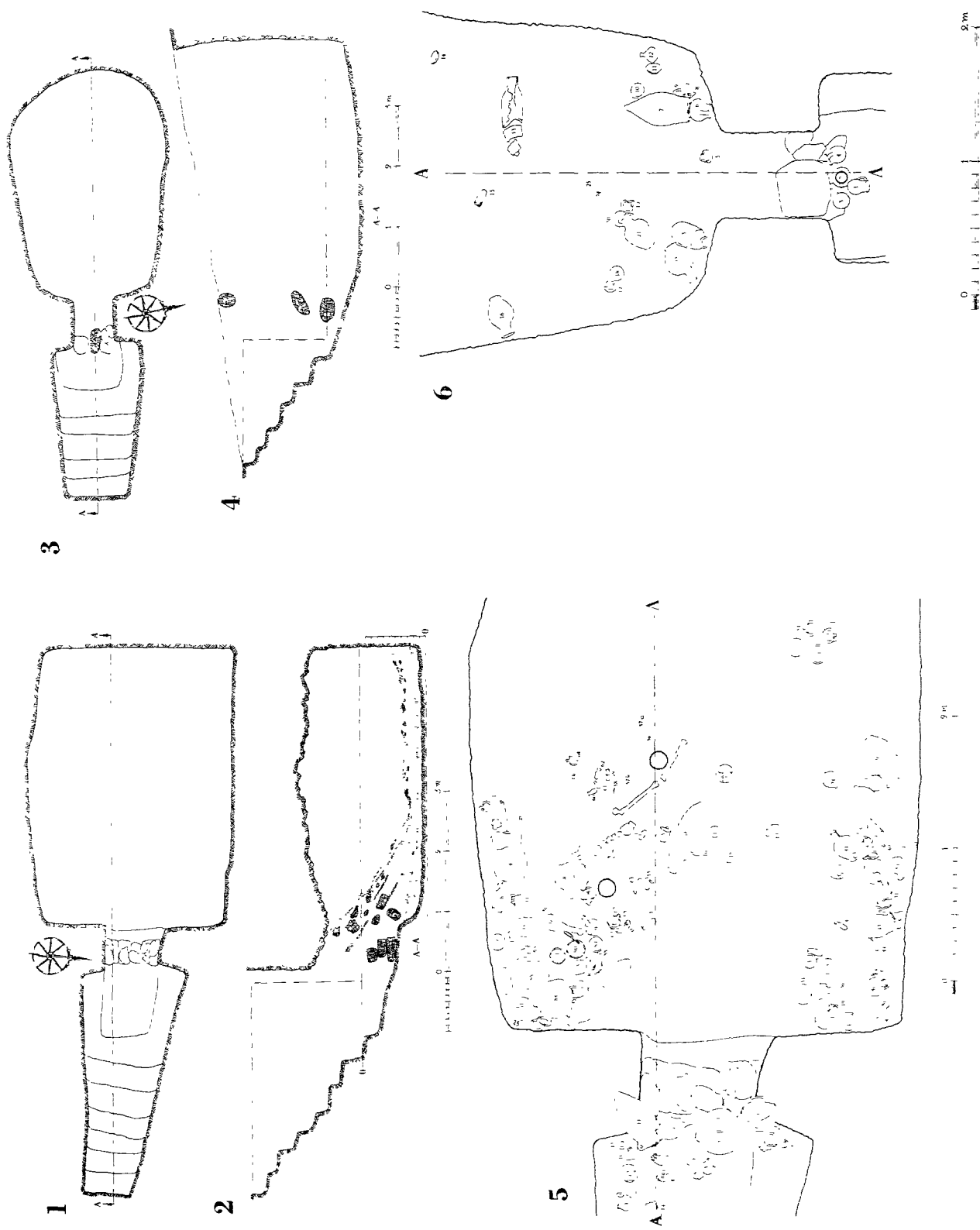

Fig. 162. Youni. Tomb 1, Plan (1); Section (2); Finds *in situ* (5). Tomb 2, Plan (3); Section (4); Finds *in situ* (6).

white rock had been chosen. This was of the same kind as certain portions of the ground in Paradisotissa. As the rock nowhere was covered by much earth, all the tombs were easily discovered. — Sixteen tombs were examined, in July 1928.

TOMB 1 (Fig. 162: 1, 2, 5)

SIZE

	Length	Width	Height
Dromos	3.80	1.70	2.60
Stomion	0.80	0.90	1.20
Chamber	4.60	3.35	1.90

SHAPE

The chamber is accessible through a rectangular dromos with perpendicular sides. Its floor is provided with eight steps which lead down to the entrance. The lowest step is continued also on the sides of the dromos. The doorway, of rectangular shape, was blocked up by some rubble most of which had fallen into the tomb. Three courses were preserved *in situ*. The floor of the chamber is situated on a somewhat lower level than the stomion floor. The chamber was rectangular in shape and provided with a barrel-vaulted roof rising directly from the floor. As most of the roof had fallen the original shape of it could be observed only in the innermost right corner.

STRATIFICATION

The dromos was filled with a rather homogeneous *chavara* which partly had come through the door-packing into the chamber. The floor of the chamber was covered with a thin layer of burial earth in which most of the finds were situated. Some of the larger vases, however, extended up into the upper layer which consisted of *chavara*-stuff from the fallen roof. This was also mixed with earth infiltrated through the entrance.

BURIALS

All the skeletal remains of this tomb were in a very bad state of preservation and it is, therefore, hardly possible to determine how many corpses had been buried in the tomb. Various remains were scattered about the floor, especially on that part which was near the entrance. A comparatively well preserved skeleton was found on the left side lying in dorsal position. This may have been the last burial. Around it, especially in the corner to the left of the entrance the remains of other skeletons were scattered about together with some vases. Similar conditions were observed on the right hand of the entrance, where some very much decayed remains of a skeleton possibly were preserved *in situ* along the wall.

Just outside the door-packing a deposit of vases was noted (Nos. 1—14). This should most likely be associated with the last burial. With the exception of this group, it seems impossible to separate the gifts of the various burials in the chamber.

FINDS (PLS. XCVIII, 8; XCIX)

D r o m o s .

1. Coarse jug with round base; bulging sides; out-turned rim; handle from rim to shoulder. Height 12.5. —60.
2. White Painted VI hydria with base-ring; bulging sides; narrow neck; annular rim; two horizontal handles on shoulder, and one vertical from neck to shoulder. Encircling lines and wavy lines around belly and shoulder; vertical strokes on handles; three pendant lines below vertical handle. Height 41.2.
3. Coarse jug, as No. 1. Height 8.7. —90.
4. White Painted VI globular jug with flat base; narrow, splaying neck; handle from rim to shoulder; short spout on shoulder opposite handle. Encircling bands on belly and neck; vertical lines on shoulder; transverse lines on handle. Height 10.5. —78.
5. Plain White VI oval jug with small foot; slightly convex neck; stilted rim. Part of neck and handle missing. Height 27.5. —60.
6. Plain White VII small jug with raised, flat base; angular shoulder; concave neck; handle from neck to shoulder; spout (missing) opposite handle. Height 8.5. —45.
7. Plain White VII amphora with knobbed base; conical body; narrow, cylindrical neck; annular rim; handles from neck to shoulder; depression at base of handle on either side. Height 63.5. —60.
8. Plain White VII oval jug with raised, flat base; bulging sides; ridge around neck; slightly inbent rim; handle from rim to shoulder. Height 16.0. —105.
9. Plain White VII juglet with flat base; concave neck; somewhat inbent rim; handle from rim to shoulder; spout opposite the handle. Height 10.0. —40.
10. Plain White VII juglet, as No. 9. Height 9.5. —105.
11. Plain White VI cone-shaped pithos with pointed base; angular shoulder; wide short rim; vertical handles below shoulder. Height 50.0. —80.
12. Coarse jug, as No. 1, but with flat base. Height 12.0. —95.
13. Coarse, sack-shaped jug with flat base; splaying, wide rim; handle from rim to shoulder. Height 14.0. —100.
14. Plain White VII jug, as No. 9. Height 9.0. —25.
21. Plain White VII sack-shaped jug with flat base; tapering body; splaying rim; handle from rim to shoulder. Height 12.0. —40.
22. Plain White VI oval, depressed jug with flat raised base; neck and handle missing. Height 15.0. —12.
23. Coarse jug, as No. 12. Height 11.0. —13.
24. White Painted VI oval jug with flat, raised base; concave neck; plain rim; handle from rim to shoulder. Encircling bands and wavy line around shoulder; vertical, perpendicular lines from neck. Height 17.5. —30.
25. Plain White VII bowl, as No. 18. Diam. 11.7. —20.
26. Plain White VI hydria, shape as No. 2. Height 40.0. —40.
27. Plain White VII pithos, as No. 20, but with somewhat bulging lower part, and with slightly convex shoulder. Height 64.0. —35.
28. Terracotta lamp, as No. 15, but with flat, raised base. Length 10.5. —22.
29. Terracotta lamp, as No. 15. Length 13.8. —30.
30. Plain White VII oval jug with flat, raised base; narrow neck with ridge; somewhat inturned rim; handle from neck to shoulder. Height 17.0. —60.
31. Terracotta lamp, as No. 15. Length 11.0. —67.
32. Plain White VII bowl with flat base; bulging sides; flat, downturned rim. Diam. 12.1. —32.
33. Coarse bowl with small, flat base; raised sides; plain rim. Diam. 12.0. —45.
34. Plain White VII bowl with raised, flat base; plain rim. Diam. 12.4. —35.
35. Plain White VII bowl with flat base; rounded sides; plain rim. Diam. 13.5. Inside No. 34.
36. Plain White VII bowl, as No. 32. Diam. 13.0. On No. 37.
37. Plain White VII bowl, as No. 32. Diam. 12.0. —30.
38. Plain White VII bowl, as No. 32. Diam. 13.0. —42.
39. Plain White VII bowl, as No. 32, but with horizontal rim. Diam. 12.5. —25.
40. Plain White VII sack-shaped jug with flat base; splaying rim; handle from rim to shoulder. Height 13.5. —20.
41. Plain White VI oval jug with base-ring; marked shoulder-line; cylindrical, narrow neck; annular rim; handle from rim to shoulder. Height 27.0. —22.
42. Alabastron with bobbin-shaped body; wide, flat rim; side-knobs surface much corroded. Height 10.2 —20.
43. White Painted VI oval jug with flat, raised base; short, wide neck; pinched rim; handle from rim to shoulder. Encircling bands and wavy line on shoulder; painted rim; vertical line on shoulder. Height 24.5. —30.
44. Plain White VI sack-shaped jug with flat base; tapering body; splaying rim; handle from rim to shoulder. Height 12.6. —29.
45. Terracotta lamp, as No. 28. Length 7.0. —20.
46. Plain White VII oval jug with flat, raised base; narrow neck; funnel-shaped mouth; slightly elevated handle from rim to shoulder. Height 20.0. —40.
47. Plain White VI sack-shaped jug with oval body; splay-

C h a m b e r .

15. Terracotta lamp with rounded, shaved base; deeply pinched wick-holder. Length 11.5. —60.
16. Plain White VII bowl with flat, raised base; inturned rim. Damaged. Diam. 7.0. —42.
17. Plain White VII bowl with flat base; flat rim. Diam. 9.2. —40.
18. Plain White VII bowl with small concave base; rounded side; plain rim. Diam. 12.7. —52.
19. White Painted VII bowl with flat base; plain rim. Encircling lines inside. Diam. 13.0. —42.
20. Plain White VII torpedo-shaped pithos with pointed base; ridged shoulder-line; concave shoulder and neck; splaying rim; vertical, small handle below shoulder. Height 56.0. —28.

- ing rim; slightly elevated handle from rim to shoulder. Height 13.5. -15.
48. Plain White VI jug, as No. 47. Height 13.5. -22
49. Terracotta lamp, as No. 15. Length 11.8. -35.
50. White Painted VI bowl with raised base; curved sides; plain rim. Encircling lines and bands inside. Diam. 13.2. -15.
51. Plain White VII bowl, as No. 32, but with flat, raised base. Diam. 14.5. -16.
52. Plain White VII bowl, as No. 51. Diam. 14.6. -20.
53. Terracotta lamp, as No. 15. Diam. 11.0. -50.
54. Terracotta lamp, as No. 15. Diam. 12.0. -15.
55. Plain White VII bowl, as No. 51. Diam. 15.0. -27.
56. Leech-shaped earring of silver; broken. Length 1.5.
57. a) Vase-shaped gold pendant; plain, with small knob at base; punctured filigree lines around base and top of neck; around upper part of neck, thread of gold passed through two holes; plain, loop-shaped mounting on top for suspension. Length 2.4. -20.
b) Bronze pin with rounded head; opposite end broken off; might be a spatula. Length 13.5. -13.
58. Fragment of iron knife; only pointed end of blade preserved; one cutting edge. Length 6.2. -13.
59. Alabastron with spindle-shaped body; short, cylindrical neck; wide rim; two side-knobs. Much corroded. Height 8.5. -13.
60. Alabastron with oval body; splaying rim; side-knobs. Height 7.5. -17.
61. Alabastron, as No. 60. Height 5.7. -18.
62. Alabastron, as No. 60. Height 8.0. -18.
63. Alabastron, as No. 59. Height 11.5. -15.
- 64-65.
Shallow bronze lamp with flat base; pinched wick-holder. The lamp (No. 64) was hanging in three chains (No. 65); the links are made of short, round rods bent in the shape of a S. Length of lamp 10.0. -20.
66. Fragments of a bronze mirror.
67. Terracotta lamp, as No. 15. Length 11.2. In No. 68.
68. Plain White VII bowl, as No. 32. Diam. 14.3. Inside No. 69.
69. Plain White VII bowl, as No. 39. Diam. 13.5. In No. 70.
70. Plain White VII bowl, as No. 32. Diam. 14.0. -52.
71. Terracotta lamp, as No. 28. Length 10.7. -18.
72. Terracotta lamp, as No. 15. One side missing. Length 10.2. -33.
73. Coarse jug with flat base; depressed shoulder; wide neck; plain rim; handle from rim to shoulder. Height 16.0. -45.
74. Plain White VI pithos, as No. 11. Painted inscription between handles (See Appendix IV). Height 51.0. -65.
75. Iron strigil with curved blade; semicircular in section fitted to a horizontal loop-handle, attached to the blade by a flat, leaf-shaped mounting. Fragmentary.
76. Plain White VII jug, as No. 8. Upper part of neck missing. Height 13.5. -90.
77. Plain White VII pithos with pointed base; parallel sides; ridged shoulder-line; annular rim, vertical, small handle on shoulder. Height 68.0. -80.
78. Plain White VII oval jug with flat, raised base; tapering neck; stilted rim; handle from rim to shoulder. Height 22.0. -40.
79. Plain White VI bowl with flat, raised base; curved sides; plain rim. Diam. 12.4. -65.
80. Fragments of a Plain White jug. -52.
- 81-82.
Pair of leech-shaped earrings of silver. Fragmentary. In the sieves.
83. Terracotta lamp, as No. 15. Length 11.5. On top of No. 84.
84. White Painted VI hydria, as No. 2. Height 41.0. -50.
85. Coarse hydria; shape as No. 2. Height 38.0. -60.
86. Plain White VI globular jug with raised base-ring; small ridge below neck; narrow neck; stilted rim; elevated handle from neck to shoulder. Height 13.5. -60.
87. Plain White VI sack-shaped jug with flat base; concave neck; splaying rim; handle from rim to shoulder. Height 14.0. -30.
88. Plain White VI oval jug with flat base; splaying rim; handle from rim to shoulder. Height 10.0. -25.
89. Plain White VI bowl with flat base; flat, horizontal rim. Diam. 13.0. +30.
90. Plain White VII bowl, as No. 32. Diam. 14.5. +40.
91. Plain White VI bowl with flat base; curved sides; rounded rim. Diam. 12.5. +35.
92. Fragment of a Plain White bowl. +28.
93. Plain White VI depressed jug with flat, raised base; narrow neck; funnel-shaped mouth; flat rim; slightly raised handle from rim to shoulder. Height 15.0. -20.
94. Terracotta lamp, as No. 15. Length 13.4. -20.
95. Plain White VII bowl, as No. 32. Diam. 14.3. -15.
96. Black Slip (VI) jug with oval body; flat, raised base; wide neck; stilted rim; handle from rim to shoulder. Height 18.8. -40.
97. Plain White VI jug, as No. 93. Height 17.5. +35.
98. White Painted VI jug, shape as No. 93, but with splaying mouth. Encircling lines and bands around belly, shoulder, and neck; small, winged lozenge as front ornament; vertical lines on handle. Height 22.5. -30.
99. Terracotta lamp, as No. 15. Length 10.5. -15.
100. Alabastron, as No. 42. Height 9.5. -15.

The distribution of the finds is shown by the following diagram:

	Pottery						Iron		Bronze		Silver	Gold	Terracotta	Alabaster		
	Wh. P. VI	Wh. P. VII	Bl. Sl. (VI)	Pl. Wh. VI	Pl. Wh. VII	Pl. Wh. VI-VII	Coarse Ware	Knife	Strigil	Mirror	Pin	Lamp	Earring	Pendant	Lamp	Bottle
Dromos	2 4			5 11	6, 7 8, 9 10, 14		1 3 12 13 -4									
Chamber	24 43 50 84 98	19	96	22, 26, 41 44, 47, 48 74, 79, 86 87, 88, 89 91, 93, 97	16, 17, 18, 20 21, 25, 27, 30 32, 34, 35, 36 37, 38, 39, 40 46, 51, 52, 55 68, 69, 70, 76 77, 78, 90, 95	80 23 33 73 85	58 75 66			57 ^b	64 ⁺ 65		56 81 ⁺ 82	57 ^a	15, 28, 29 31, 45, 49 53, 54, 67 71, 72, 83 94, 99	42, 59, 60 61, 62, 63 100
	-5	-1	-1	-15	-28	-2 -4	-1 -1 -1	-1 -1 -1	-1 -1 -1	-2	-1	-14	-7			

CHRONOLOGY

On account of the fact that the various burials had been mixed in the chamber, there is no possibility of separating them chronologically. The following wares are represented: White Painted VI—VII, Black Slip VI, Plain White VI—VII, and Coarse Wares. This combination of pottery determines that the tomb was in use from the end of the Cypro-Classic I throughout the Cypro-Classic II periods.

TOMB 2 (Figs. 162: 3, 4, 6; 163)

SIZE

	Length	Width	Height
Dromos	2.55	1.40	2.00
Stomion	0.75	0.65	—
Chamber	3.80	2.60	—

SHAPE

The dromos is comparatively short and steep, practically rectangular in shape, and provided with six steps excavated in the rock. The lowest step is continued along the right dromos wall. The stomion is narrow. The upper parts of it were damaged so that only a narrow strip of the rock remained above the doorway. The door-packing consisted of round rubble blocks preserved in two courses at the bottom. The chamber is oblong and has rounded corners. Its floor is somewhat concave with the deepest part in the centre. The tomb had collapsed completely so that nothing of the roof was preserved. This collapse, however, had not taken place on one occasion only. The soft rock seems to have crumbled slowly



Fig. 163. Vouni. Tomb 2. Finds *in situ*.



Fig. 164. Vouni. Tomb 4. Entrance into the chamber.

so that small pieces of it fell down on the floor during a long period. In this way only little damage had been caused to the burial-gifts on the floor.

STRATIFICATION

The filling in this tomb was almost homogeneous all through. The ordinary *chavara*-filling occupied most of the tomb. Only on the floor of the chamber a very thin layer of dark earth was found as a contrast to the rest of the filling. All the finds were associated with this layer.

BURIALS

No skeletal remains were preserved. The burial-gifts, however, seem all to have been found on their original places. Thus, on either side of the entrance in the chamber, deposits of vases were found *in situ*, some vessels leaning against the wall. On the right side Nos. 5—12 were found whereas Nos. 17—23 were placed to the left. The rest of the gifts were scattered all over the floor. A closed group of vases (Nos. 1—4) were found outside the door-packing almost on the dromos floor.

FINDS (PL. C)

Dromos.

1. Coarse jug with flat base; depressed body, wide neck; plain rim; handle from rim to shoulder. Height 15.0
2. Coarse jug, as No. 1, but with raised, flat base. Height 19.0.
3. Coarse bowl, flat base, somewhat angular sides; flat rim. Diam 12.5.
4. Coarse jug, as No. 1. Height 14.0

Chamber.

5. Shallow terracotta lamp with pinched wick-holder; shaved base. Length 10.5. Floor.
6. Plain White VII depressed jug with rounded base; wide, tapering neck; stilted rim; handle from rim to shoulder. Height 17.0. Floor.
7. Plain White VI cone-shaped pithos with double-curved

- outline; marked shoulder line; short, wide rim; handles below shoulder; one side damaged. Height 48.0. Floor.
8. Plain White VI oval jug with flat base; tapering neck; splaying rim; handle from rim to shoulder. Height 10.0. Floor.
 9. Terracotta lamp, as No. 5. Length 10.3. Floor.
 10. Coarse jug, as No. 1. Height 11.5. Floor.
 11. Plain White VI bowl with small, concave base; curved sides; slightly out-turned rim. Diam. 12.1. Floor.
 12. Plain White VI biconical jug with flat base; narrow neck; small, funnel-shaped mouth; slightly raised handle from rim to shoulder. Height 13.0. Floor.
 13. Plain White VII torpedo-shaped pithos; fragmentary. Floor.
 14. Plain White VI bowl with flat, raised base; curved sides; plain rim. Diam. 11.2. Floor.
 15. Plain White VI sack-shaped jug with flat base; long oval body; concave neck; plain rim; somewhat raised handle from rim to shoulder. Height 12.5. Floor.
 16. Plain White VII oval jug with flat, raised base; sloping shoulder; cylindrical neck; stilted rim; handle from neck to shoulder. Height 29.5. Floor.
 17. Terracotta lamp, as No. 5, but with flat, raised base. Length 9.5. Floor.
 18. Plain White VI bowl, as No. 14. Diam. 12.2. Floor.
 19. Terracotta lamp, as No. 5. Length 10.5. Floor.
 20. Plain White VI bowl, as No. 14. Diam. 12.2. Floor.
 21. Plain White VII jug, as No. 16. Height 29.0. Floor.
 22. Plain White VI depressed, oval jug; base-ring; narrow neck; funnel-shaped mouth with flat, horizontal rim; twin-handle from rim to shoulder. Height 31.5. Floor.
 23. Plain White VII torpedo-shaped pithos; pointed base; parallel sides; concave neck; splaying rim; vertical handle on side (missing). Height 67.0. Floor.
 24. Finger-ring of iron with oval bezel. Fragmentary. Diam. 2.0. Floor.
 25. a) Bobbin-shaped bead of cornelian, pierced lengthwise. Length 1.1.
b) Globular depressed bead of blue and white glass, pierced through centre. Diam. 0.7. Floor.

The distribution of the finds is shown by the following diagram:

	Pl. Wh. VI	Pl. Wh. VII	Coarse Ware	Iron	Terracotta	Glass	Semi-precious stone
				Finger-ring	Lamp	Bead	Cornelian bead
Dromos			1, 2, 3, 4 -4				
Chamber	7, 8, 11 12, 14, 15 18, 20, 22 -9	6, 13, 16 21, 23 -5	10 -1	24 -1	5, 9 17, 19 -4	25 b -1	25 a -1

CHRONOLOGY

Plain White VI and VII, and Coarse Wares are represented. Types VI are in majority. On account of this, the tomb is dated to the beginning of the Cypro-Classic II period.

TOMB 3 (Figs. 165; 166; 167: 1-3; 168)

SIZE

	Length	Width	Height
Dromos	3.35	1.35	2.20
Stomion	0.50	1.60	0.80
Chamber	3.60	3.20	1.60

SHAPE

This isolated tomb was accessible through a narrow dromos which widens downwards. The beginning of the dromos slopes steeply to a plain floor in front of the doorway. The



Fig. 165. Vouni. Tomb 3. Deposit in dromos.



Fig. 166. Vouni. Tomb 3. Complete vases in the debris of the collapsed roof.

stomion is merely hinted. Only the left jamb is indicated. The doorway was blocked up by a packing, very loose, consisting of flat rubble of various size. The packing was preserved *in situ*. The chamber is irregularly trapezoid in shape and has its floor on a somewhat lower level than the dromos floor. As to the roof of the chamber parts of it have fallen down upon the floor. This was the case near the door and close to the rear wall. Judging by the preserved portions of the roof, however, it was of slightly pointed barrel-shape with the beginning of the vault near the floor.

STRATIFICATION

The dromos filling was homogeneous, consisting of grey earth with minor pieces of *chavara* rock. The floor of the chamber was covered with a very thin layer of dark earth which extended all over the floor in a significant way. On top of this, a great amount of small pieces of pine-wood was found which were located especially in the middle of the tomb but found also near the walls. In fact, all the finds of the chamber rested on this layer of wood. Most likely this should be interpreted as a wooden floor on which the corpses were buried. The presence of wood all over the floor seems to exclude the explanation that the wood had come from wooden sarcophagi, especially as the skeletal remains were not associated with the spots where most of the wood was concentrated. On top of this bottom layer, debris from the fallen-in roof was situated, near the door-packing, mixed with earth infiltrated from the dromos.

BURIALS

In the dromos, a well preserved deposit of vases was cleared just outside the upper part of the door-packing. The vases were piled up against the door-packing most of them being turned upside down. These vases are Nos. 1—12 and the lamp, No. 13. The interior of the chamber was intact except the debris of the roof. To the left of the entrance some vases were piled up into a heap or were lying in the close vicinity of the same. No skeleton could be associated directly with this deposit; about in the middle of the floor, however, a very damaged skull was found near the bowl, No. 41. The original position of this skull may be indicated by the earrings, Nos. 43—45. Another, better preserved skull was found to the right of the entrance close by the jug, No. 39. Other fragments of tibiae were noted close to the rear wall. As far as this evidence shows, two or three corpses ought to have been buried in the tomb. Most likely all the burial-gifts represent the last burial as their places seem to be intact. The deposit in the dromos must also belong to the last burial.

FINDS (PLS. CI, CII, I)

D r o m o s.

1. Plain White VII pithos with knobbed base; oval body; rather depressed shoulder; narrow neck, thickening below the rim; annular rim; vertical handle from neck to shoulder. Height 78.0.
2. Coarse jug with flat base; depressed body; Wide neck with plain rim; handle from rim to shoulder. Height 13.0.
3. Coarse jug, as No. 2. Height 13.0.
4. Plain White VII torpedo-shaped pithos with pointed base; parallel sides; concave neck; annular rim; vertical handle below shoulder. Height 65.0.
5. Fragments of a Plain White jug with round base; short, concave neck.
6. Plain White VII depressed jug with flat base; narrow neck; rim missing; vertical handle; spout opposite the handle on shoulder. Part of handle missing. Height 12.5.
7. White Painted VI oval jug with base-ring; narrow neck; upper part and handle missing. Encircling lines and bands. Height 20.0.
8. White Painted VI oval jug, as No. 7. Height 22.0.
9. Plain White VII pithos with knobbed base; depressed, oval body; wide shoulder; narrow, cylindrical neck; flat, somewhat out-turned rim; handle from neck to shoulder. Height 60.0.
10. Plain White VII oval jug with flat base; concave neck; pinched rim; handle from rim to shoulder. Height 27.0.
11. Coarse, depressed jug with round base; wide, concave neck; plain rim; handle from rim to shoulder. Height 11.0.
12. Coarse jug, as No. 2. One side missing. Height 12.5.
13. Shallow terracotta lamp; pinched wick-holder; shaved base. Length 12.0.
14. Plain White VII sack-shaped jug with flat base; concave neck; splaying rim; handle from rim to shoulder. Height 11.0. Floor.
15. Plain White VII sack-shaped jug with flat base; cylindrical body; concave neck, splaying rim; thick handle from rim to shoulder. Height 11.0. Floor.
16. Plain White VII sack-shaped jug with flat base; cylindrical body; concave neck, splaying rim; thick handle from rim to shoulder. Height 11.0. Floor.
17. Alabastron, much corroded. Height 8.0. Floor.
18. Plain White VII oval jug with flat base; narrow neck; pinched rim; handle from rim to shoulder. Height 24.0. Floor.
19. Bichrome Red IV (VII) jug with raised base-ring; oval body; narrow neck widening upwards; flat rim; twin-handle from neck to shoulder with side-knobs at neck. Encircling white and black lines on body, shoulder, and neck; black, wavy band and oblique strokes on shoulder; white dotted lines around neck and rim; black crosses on side-knobs; transverse lines on handle. Height 24.0. Floor.
20. Shallow terracotta lamp, as No. 13. Length 11.5. Floor.
21. Plain White VI amphora; knobbed base; bulging sides gently concave neck; rim missing; handles from neck to shoulder. Height 50.0. Deposit.
22. White Painted VI depressed, oval hydria with base-ring; narrow, cylindrical neck; annular rim; two horizontal handles on shoulder; one handle from neck to shoulder. Encircling bands and wavy lines around belly, shoulder, and neck; perpendicular lines on upper part of shoulder; lines along handles; stroke on either side at base of handles. Height 45.0. Deposit.
23. Bichrome Red III (VI) oval jug with raised base-ring; narrow, softly curved neck; flat rim; twin-handle from neck to shoulder with side-knobs at neck. Encircling black and white lines around base-ring, body, and neck; around belly, wreath with white, lancet-shaped leaves; on shoulder, alternating conventionalized flowers and palmettes, and above these a wreath of double leaves and buds; transverse, black and white lines on rim; black and white crosses on side-knobs; black and white strokes on handle. Height 35.0. Deposit.

C h a m b e r.

14. Plain White VI torpedo-shaped pithos with pointed base; body somewhat widening upwards; angular shoulder-line; concave neck; wide, flat rim; vertical handle on side below shoulder. Height 54.0. Floor.
15. Plain White VI sack-shaped jug with flat base; oval body;

24. Plain White VI sack-shaped jug with flat base; long, oval body; concave neck; splaying mouth; handle from rim to shoulder. Height 15.0. Deposit.
25. Plain White VI bowl with small, flat base; curved sides; plain rim. Diam. 13.0. Deposit.
26. Plain White VI jug, as No. 24. Height 15.5. Deposit.
27. Plain White VI bowl with flat base; curved sides; somewhat out-turned rim. Diam. 12.0. Deposit.
28. Bichrome Red III (VI) jug with raised base-ring; oval body; slightly concave neck; flat, horizontal rim; twin-handle from neck to shoulder with side-knobs at neck. Encircling black and white lines around body, shoulder, and neck; black dotted lines around neck; groups of perpendicular white lines on shoulder. Height 38.0. Deposit.
29. Shallow terracotta lamp, as No. 13. Length 11.0. Deposit.
30. White Painted VI hydria, as No. 22. Encircling bands and wavy lines around body, neck, and rim; horizontal handles black painted. Height 43.0. Deposit.
31. Bichrome Red III (VI) jug, as No. 28. Encircling black lines around body and neck; wreath of lancet-shaped leaves on shoulder; paintings on rim and handle; damaged. Height 28.0. Deposit.
32. Bichrome Red III (VI) jug, as No. 28. Encircling black and white lines and bands around belly and neck; two wreaths of white lancet-shaped leaves on shoulder and neck; on shoulder, perpendicular strokes; white painted rim with transverse, black lines. Height 26.0. Deposit.
33. Bichrome Red III (VI) jug, as No. 28. Encircling black and white lines and bands around body and neck; on shoulder, wreath of lancet-shaped leaves; white dotted lines around neck; white kymation on rim; side-knobs with black crosses on white ground. Height 36.5. Deposit.
34. Shallow terracotta lamp, as No. 13. Length 11.0. Deposit.
35. Plain White VI depressed jug with flat base; concave neck; plain mouth; handle from rim to shoulder. Height 17.0. Deposit.
36. Plain White VI jug, as No. 24. Height 16.0. Deposit.
37. Plain White VI jug, as No. 35. Height 18.0. Deposit.
38. Bichrome Red III (VI) jug, as No. 28. Encircling white and black lines and bands around belly, shoulder, and neck; on shoulder two encircling lines of white and black perpendicular strokes; around neck, black and white dotted line; black crosses on side-knobs. Height 30.0. Deposit.
39. Terracotta lamp, as No. 13. Length 10.5. Deposit.
40. Bichrome Red IV (VII) jug, as No. 19. Encircling black lines around body and neck; on shoulder, encircling wavy line; from base of handle rough strokes hanging down over body. Slip and decoration worn. Height 22.0. Floor.
41. Plain White VI bowl with small, flat base; curved sides; somewhat out-turned rim. Diam. 12.0. Floor.
42. Black Glazed lamp with wide, flat base; depressed body somewhat inturned, wide rim; horizontal handle below rim (missing); nozzle opposite the handle. Length 10.0. Floor.
43. a) Pair of leech-shaped earrings of silver; upper part partly missing. Length 1.6. Floor.
b) Pair of earrings of silver, as No. 43 a, but thicker. Length 2.0. Floor.
44. Two hair-rings of silver; circular in section. Diam. 2.0. Floor.
45. Pair of earrings of silver, as No. 43 b. Length 2.4. Floor.
46. a) Spatula of bronze with one end slightly thickening; the opposite end flattened. Length 9.0. Floor.
b) Fragment of a bronze pin with thickening head; pointed end missing; broken into three pieces. Length 6.2. In the sieves.
47. Circular button of bone with one side flat, the other convex, pierced through centre. Encircling, incised line on convex side. Diam. 1.6. Floor.

The distribution of the finds is shown by the following diagram:

	Pottery							Bronze		Silver		Bone	Terra-cotta	Alabaster
	Wh. P. VI	Bichrome Red III (VI)	Bichrome Red IV (VII)	Pl. Wh. VI	Pl. Wh. VII	Pl. Wh. VI-VII	Coarse Ware	Pin	Spatula	Hair-ring	Earring	Button	Lamp	Bottle
Dromos	7 8 -2				1, 4, 6 9, 10 -5	5 -1	2, 3 11, 12 -4						13 -1	
Chamber	22 30	23, 28 31, 32 33, 38	19, 40	14, 15, 21 24, 25, 26 27, 35, 36 37, 41	16, 18			46 b	46 a	44	43 a 43 b 45	47	20, 29 34, 39 42	17
	-2	-6	-2	-11	-2			-1	-1	-1	-3	-1	-5	-1

CHRONOLOGY

The finds of dromos and chamber seem to have been deposited contemporaneously. White Painted VI, Bichrome Red III (VI) and IV (VII), Plain White VI—VII, and Coarse Wares are represented. Types VI are in great majority. This combination of pottery assigns the tomb to the beginning of the Cypro-Classic II period.

TOMB 4 (Figs. 164; 167: 4—6)

SIZE

	Length	Width	Height
Dromos	2.55	1.90	1.55
Stomion	0.60	1.75	—
Chamber	3.50	2.50	—

SHAPE

The dromos is rather wide and short. It slopes steeply towards the entrance, the floor being provided with seven steps, the last of which is prolonged on the sides. The door-packing, consisting of minor rubble and two large, raised blocks, is intact. The stomion is well marked and comparatively narrow. The lintel-piece has gone almost entirely so that only a narrow strip of it remains (Fig. 164). The interior of the tomb is rectangular in shape. The floor is somewhat below the stomion level. On three of the sides there are niches which occupy almost the whole of the walls. They are excavated in the rock about one metre above the floor of the chamber. The roof had collapsed entirely. It is therefore impossible to make any suggestions as to its original shape.

STRATIFICATION

The dromos filling consisted of homogeneous brown earth mixed with *chavara*-stuff. There was no differentiation indicating that its layers had been disturbed in any way. The interior of the tomb was filled with debris of the fallen-in roof, on top of which the surface layer was found, filling the entire cavity since the roof collapsed. Just inside the door-packing some earth had infiltrated from the dromos.

BURIALS

The interior of the tomb was intact as far as could be ascertained. The collapsed roof had not much injured the finds on the floor of the chamber. Evidently there was no sudden collapse of the entire roof, which seems to have slowly dissolved and fallen down in small pieces over the vases on the floor. In consequence of this the few finds of the tomb were comparatively well preserved. No remains of the corpses could be distinguished anywhere. To the left of the entrance, a pithos (No. 3) was found in upright position leaning against the wall, and close by, the small jug (No. 2). The lamp (No. 1) was found on the floor in the stomion.

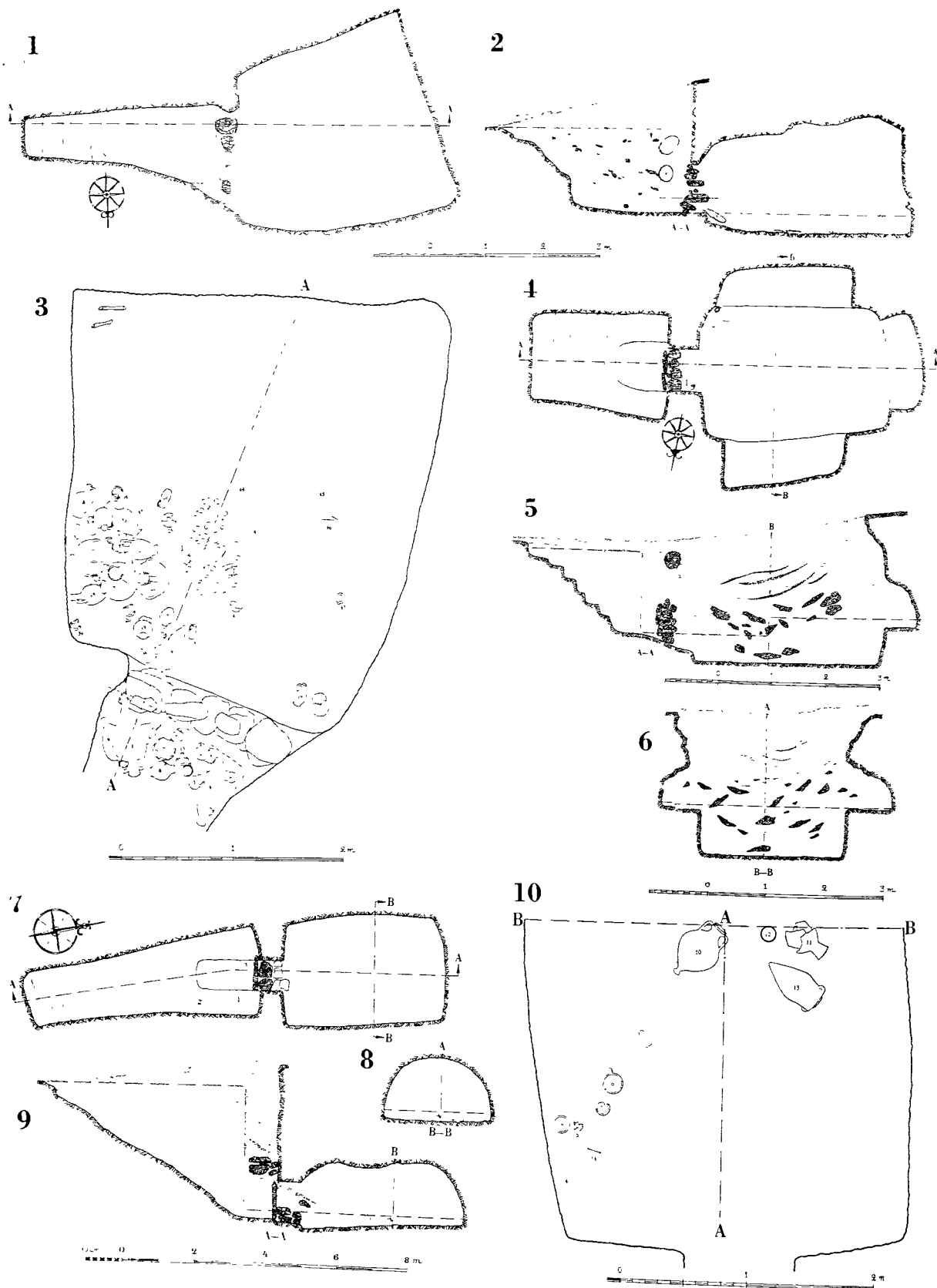

Fig. 167. Vouni. Tomb 3, Plan (1); Section (2); Finds *in situ* (3). Tomb 4, Plan (4); Sections (5, 6). Tomb 6, Plan (7); Sections (8, 9); Finds *in situ* (10).

FINDS (PL. CII, 3)

1. Terracotta lamp with pinched wick-holder; flat base. Length 11.1. Floor.
2. Plain White VII sack-shaped jug with flat base; splaying mouth; handle from rim to shoulder. Height 11.5. Floor.
3. Plain White VII torpedo-shaped pithos; pointed base; par allelsides; concave, splaying mouth; vertical handle on side below shoulder; painted inscription below shoulder (See Appendix II). Height 68.0. Floor.

CHRONOLOGY

The few finds of this tomb date it to the Cypro-Classic II period.

TOMB 5 (Pl. CII, 2)

This tomb consisted of a mere cavity excavated in the rock. At the bottom, the jug (No. 1) was found together with some much decayed remains of a skeleton. Judging by the jug the tomb should be dated to the Cypro-Classic II period.

TOMB 6 (Figs. 167: 7—10; 169)

SIZE

	Length	Width	Height
Dromos	6.50	2.40	4.20
Stomion	0.70	0.80	1.10
Chamber	4.30	2.90	1.70

SHAPE

In comparison with the previous tombs this has an exceptionally large dromos which slopes steeply down to a small depression just in front of the entrance. This was found blocked up by a large, raised door-slab which remained *in situ*. The upper corner of it, however, had been knocked off so that one could enter the tomb through the hole. Inside the raised slab there were two courses of rubble placed like a threshold. The stomion is well marked and narrow. The chamber is practically rectangular, though the sides are somewhat curved. The roof is barrel-vaulted and slightly irregular.

STRATIFICATION

The dromos filling consisted of grey or light-brown earth, hard in consistence and homogeneous. Near the wall above the entrance, a shaft had been dug into this filling. It extended to the upper part of the door-slab and was filled with rather loose, dark earth. On the bottom of the shaft, some large rubbles were found. Both the original filling of the dromos, and earth from the shaft had infiltrated into the chamber through the hole in the slab, the dark earth visible as a thin layer on top of the light dromos filling. The interior portions of the chamber were entirely empty. Evidently the tomb had been visited by robbers who had excavated the shaft in the dromos and entered the tomb through the hole in the door-slab.



Fig. 168. Vouni. Tomb 3. Door-packing.

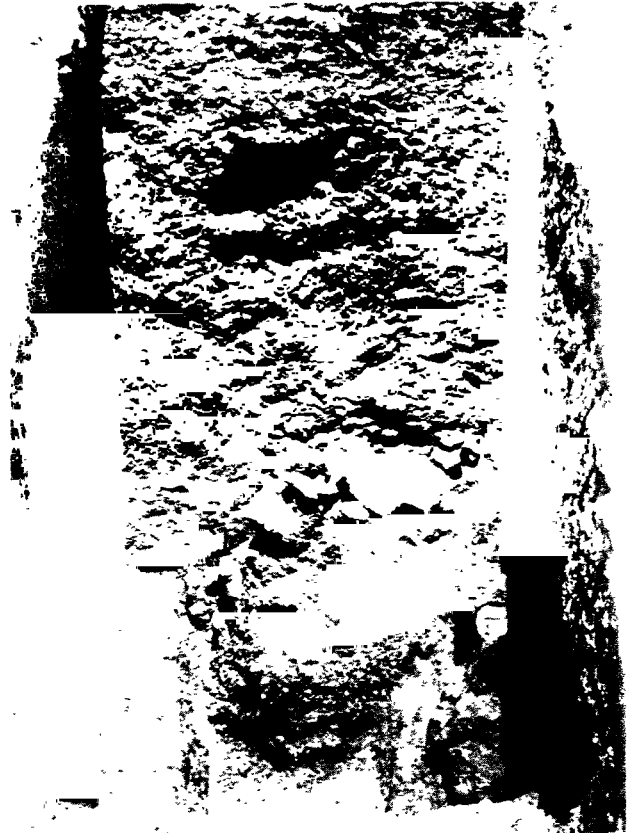

Fig. 169. Vouni. Tomb 6. Dromos.

BURIALS

No skeletal remains were found, and the original positions of the tomb-gifts could not be ascertained due to the operations of the tomb-robbers. Most of the finds were made in the left part of the chamber. Some of the larger vases were piled up in the middle (Nos. 10—13). Two small vases were found near the surface layer in the dromos (Nos. 1—2). The bowl (3) may originate in the tomb. It was found on the bottom of the dromos shaft excavated by the tomb-robbers, and may have been brought up by them.

FINDS (PL. CII, 4)

Dromos

- 1 Plain White VI bowl with small, flat base; curved sides; somewhat out-turned rim. Diam. 11.8.
2. White Painted VI miniature jug with flat base; oval body, concave, narrow neck; raised handle from rim to shoulder. Upper part from shoulder red painted. Rim missing Height 6.0.
- 3 Plain White VII bowl with flat, raised base; slightly curved sides; incurved rim, shape imitating Black Glazed bowls Diam. 12.2.

Chamber.

- 4 Fragments of an alabastron. Floor.
5. Plain White VII sack-shaped jug with flat base; oval body; concave neck; handle from rim to shoulder. Height 13.0. Floor.
6. Deep Coarse bowl with flat base; curved sides; flat, inturned rim; handle from rim to body. Diam. 16.0. Floor.
7. Terracotta lamp with pinched wick-holder; shaved base. Length 11.5. Floor.

8. Fragment of a Plain White bowl. Floor.
9. Plain White VII bowl with flat base; flat, horizontal rim. Diam. 14.0. Floor.
10. Plain White VII amphora with knobbed base; biconical body; narrow neck, widening upwards; flat, horizontal rim; handles from neck to shoulder with a depression at base of handle of either side. Height 51.0. Floor.
11. White Painted VI hydria with base-ring; oval, depressed body; short, narrow neck with annular rim; horizontal handles on shoulder; vertical handle from neck to shoulder. Encircling bands and wavy lines around shoulder and neck. Height 41.2. Floor.
12. Plain White VII bowl, as No. 9. Diam. 13.2. Floor.
13. Plain White VI cone-shaped pithos with double-curved outline; pointed base; angular shoulder; short, wide rim; handles on body below shoulder. Height 50.0. Floor.
14. Pigment-rod of bronze with thickening ends; broken. Length 12.2. Floor.

The distribution of the finds is shown by the following diagram:

	P o t t e r y					Bronze	Terracotta	Alabaster
	Wh. P. VI	Pl. Wh. VI	Pl. Wh. VII	Pl. Wh. VI-VII	Coarse Ware	Pigment-rod	Lamp	Bottle
Dromos	2 -1	1 -1	3 -1					
Chamber	11 -1	13 -1	5, 9, 10, 12 -4	8 -1	6 -1	14 -1	7 -1	4 -1

CHRONOLOGY

As regards the finds in the chamber White Painted VI, Plain White VI—VII, and Coarse Wares are represented. As Types VI and VII are about equal, the tomb may be dated to the middle of the Cypro-Classic II period.

TOMB 7 (Figs. 172: 1—3; 174)

SIZE

	Length	Width	Height
Dromos	4.70	2.40	3.00
Stomion	0.40	0.80	—
Chamber	5.20	3.60	1.85

SHAPE

The dromos is of ordinary shape with some irregularities. There are thus steps just in the beginning and in the end. In front of the entrance into the chamber, the usual depression is noted having a sloping floor. On the left side there is a niche in the dromos wall. The entrance was blocked up by a door-slab which was found upright but somewhat removed from its original place. The stomion is well marked in plan but its upper portions had been damaged by the collapse of the roof of the chamber. The shape of the chamber is roughly rectangular with rounded corners. The roof was probably barrel-vaulted. It had partly fallen down over the floor, especially the parts near the entrance.

STRATIFICATION

The dromos was filled with a homogeneous brown earth mixed with *chavara*-stuff. In this filling, the finds, Nos. 42—46, were lying. The interior of the tomb was practically filled with earth which had infiltrated from the entrance. In the E. portion, however, the *chavara*-stuff from the roof covered the floor and the finds on it. Almost all over the floor a thin layer of dark-brown earth was noted. The roof had not collapsed suddenly but slowly crumbled and fallen down in small pieces, so that most of the vases below the debris were preserved almost completely, as in some of the tombs described above.

BURIALS

Since the filling in the chamber had been removed it was evident that the burial-gifts were preserved more or less *in situ*. In any case the tomb had not been visited by robbers. All the skeletons had decayed entirely, but the position of the burial-gifts indicated the arrangements in the tomb. Evidently, Nos. 3—25 constitute a more or less closed group which can be connected with a burial on the left of the tomb, while Nos. 27—41 should be ascribed to a burial along the right side-wall.

FINDS (PLS. CIII, CV, I)

C h a m b e r.

1. Plain White VI bowl with flat base; curved sides; plain rim. Diam. 12.0. Floor.
2. Alabastron with rounded base, somewhat curved, tapering body; concave neck; wide, flat rim, side-knobs. Length 12.5. Floor.
3. Plain White VII torpedo-shaped pithos with pointed base, slightly convex sides; curved shoulder; concave neck; flat rim; vertical handles below shoulder. Height 71.0. Floor.
4. Plain White VII conical amphora with knobbed base; wide shoulder; gently curved neck; flat, horizontal rim; handles from neck to shoulder. Height 53.0. Floor.
5. White Painted VI oval jug with base-disc; sloping shoulder; cylindrical neck; slightly out-turned rim; handle from neck to shoulder. Encircling lines and bands around belly, body, neck, and rim; small, winged lozenge as front ornament below neck; vertical stroke along handle and two strokes on either side of handle, on shoulder. Height 37.0. Floor.
6. Plain White VII amphora with knobbed base; conical body; cylindrical neck; annular rim; handles from neck to shoulder. Height 60.0. Floor.
7. Plain White VI oval jug with raised, flat base, narrow, concave neck; splaying, plain rim; moulded handle from rim to shoulder. Height 20.5. Floor.
8. Plain White VII sack-shaped jug with flat base; concave neck; splaying rim, handle from rim to shoulder. Height 12.5. Floor.
9. Plain White VI jug, as No. 7. Height 20.0. Floor.
10. Coarse, oval jug with flat base; sloping shoulder; slightly concave neck; splaying rim; handle from rim to shoulder. Height 24.0. Floor.
11. Coarse, depressed jug with rounded base; wide, concave neck; splaying rim; handle from rim to shoulder. Height 13.0. Floor.
12. Plain White VII jug, as No. 8. Height 12.2. Floor.
13. Plain White VII shallow bowl with flat base; slightly angular outline; plain rim. Diam. 12.9. Floor.
14. Plain White VII bowl, as No. 13. Diam. 12.0. Floor.
15. Plain White VII bowl, as No. 13. Diam. 12.0. Floor.
16. Coarse jug, as No. 10. Height 17.2. Floor.
17. Plain White VII shallow bowl with flat base; inturned rim. Diam. 11.0. Floor.
18. Statuette of terracotta; snow-man technique; fragmentary. In No. 19.
19. Bichrome VII bell-shaped lid crowned by a roughly sculptured head. Alternating black and red strokes radiating from top. Height 6.5. Floor.
20. Plain White VII bowl, as No. 13. Diam. 11.5. Floor.
21. Plain White VI torpedo-shaped pithos with pointed base; sides somewhat widening upwards; convex shoulder; cylindrical neck; flat, horizontal rim. Height 58.0. Floor.
22. Shallow terracotta lamp with flat base; pinched wick-holder. Length 10.0. Floor.
23. Alabastron, as No. 2. Surface corroded; one side partly missing. Height 13.0. Floor.
24. Shallow terracotta lamp, with pinched wick-holder; rounded, shaved base. Length 12.0. Floor.
25. Plain White VII sack-shaped jug, as No. 8. Height 14.0. Floor.
26. Terracotta lamp, as No. 24. Length 11.0. Floor.

- 27. Plain White VII sack-shaped jug, as No. 8. Height 13.5. Floor.
- 28. Coarse jug with flat base; depressed body; wide neck; plain rim; handle from rim to shoulder. Height 11.7. Floor.
- 29. Terracotta lamp, as No. 24. Length 12.0. Floor.
- 30. Plain White VII bowl, as No. 17. Diam. 12.0. Floor.
- 31. Terracotta lamp, as No. 24. Length 10.5. Floor.
- 32. Terracotta statuette representing figure standing close to a cylindrical object with both arms holding the edge of it; snow-man technique. Height 8.0. Floor.
- 33. Plain White VII bowl, as No. 17. Diam. 11.5. Floor.
- 34. Coarse oval jug, as No. 10. Height 28.0. Floor.
- 35. Coarse terracotta lid with curved upper side; central knob. Diam. 15.1. Floor.
- 36. Coarse, oval jug, as No. 10. Height 29.0. Floor.
- 37. Alabastron, as No. 2. Height 12.5. Floor.
- 38. Plain White VII sack-shaped jug, as No. 8. Height 16.5. Floor.
- 39. Plain White VII pithos, as No. 3. Base missing. Height 58.0. Floor.

- 40. Plain White VII pithos, as No. 3. Height 68.0. Floor.
- 41. Plain White VII pithos, as No. 3. Height 67.0. Floor.

D r o m o s.

- 42. Fragment of a bronze strigil.
- 43. Terracotta lamp, as No. 22. Length 11.5
- 44. Plain White VII oval jug with flat, raised base; gently curved neck; plain rim; handle from rim to shoulder; short spout opposite the handle. Height 12.2.
- 45. Plain White VII depressed jug with flat, raised base; sloping shoulder; funnel-shaped mouth; handle from rim to shoulder. Height 17.0.
- 46. Coarse cooking-pot with rounded base; raised, splaying rim; vertical handle on shoulder. Two encircling incised lines around shoulder. Part of body and rim, one handle missing. Height 15.0.
- 47. White Painted VI oval jug with raised, flat base; slightly concave neck; annular rim; handle from neck to shoulder. Encircling lines and bands around body, neck, and rim; wavy line around shoulder; vertical stroke along handle. Height 32.0.

The distribution of the finds is shown by the following diagram:

	P o t t e r y					Bronze	Terracotta	Alabaster	
	Wh. P. VI	Bichrome VII	Pl. Wh. VI	Pl. Wh. VII	Coarse Ware	Strigil	Lamp	Statuette	Bottle
Dromos			47 -1	44, 45 -2	46 -1	42 -1	43 -1		
Chamber	5	19	1, 7 9, 21	3, 4, 6 8, 12, 13 14, 15, 17 20, 25, 27 30, 33, 38 39, 40, 41	10, 11 16, 28 34, 35 36		22 24 26 29 31	18, 32	2, 23, 37
	-1	-1	-4	-18	-7		-5	-2	-3

CHRONOLOGY

White Painted VI, Bichrome VII, Plain White VI—VII, and Coarse Wares are represented. Types VII are by far in majority. This combination of pottery dates the tomb to the later part of the Cypro-Classic II period.

TOMB 8 (Figs. 170; 172: 4—6; 173: 1; 175)

SIZE

	Length	Width	Height
Dromos	6.10	3.25	3.40
Stomion	0.90	1.10	1.30
Chamber	7.00	4.00	2.00



Fig. 170. Vouni. Tomb 8. Dromos with offering pithos *in situ*.



Fig. 171. Vouni. Tomb 10. Skeleton *in situ*.

SHAPE

This is the most magnificent tomb among those excavated on the necropolis hill. The E. slope of it contains a comparatively hard, white rock which seems to have been extremely suitable for excavating caves. The dromos of Tomb 8 is wide and deep, provided with perpendicular sides and a regular stair which consists of sixteen steps. The stomion is well preserved with a rectangular doorway which was found blocked up with rubble and raised ashlar. Just inside the stomion there are two steps down to the floor of the chamber. This is roughly rectangular in shape. A ledge, 30 cm. high, is noted along the rear wall and parts of the sides. A niche is excavated in the rear wall close below the roof. It is oblong in shape. The roof is barrel-vaulted and starts directly from the floor. Through a hole in the innermost right corner there is a passage into Tomb 9. The hole had been made by robbers coming through that tomb.

STRATIFICATION

The stratification of the tomb is very simple. The dromos layers were intact. They consisted of a homogeneous grey earth directly below the surface layers. Some of the dromos

earth had infiltrated through the door-packing into the chamber so that half of its floor was covered. The rest of the floor was covered by a thin layer of brown earth, probably remains of the burials. The tomb-robbers had caused some disturbances in the natural layers in the chamber.

BURIALS

The state in which the burial-gifts were found in the chamber indicated that the tomb-robbers had made it impossible to draw any conclusions as to the original burials. The contents of the chamber were scattered about all over the floor and the heaps of earth near the entrance. In the dromos, however, everything was intact. With the exception of a few vases found in the upper layers of the dromos (Nos 1—5) a large amphora (No. 9) had been placed upside down just outside the entrance (cf. Figs. 170 and 172, 6), evidently as a votive offering. On the floor, outside the entrance, two coarse jugs (Nos. 7—8) and a bronze mounting (No. 6) were found.

FINDS (PLS. CIV, CV, 2)

D r o m o s.

1. Plain White VII miniature jug with flat base; squat body; neck tapering upwards; annular rim; handle from rim to shoulder. Height 4.3. Surface layer.
2. Plain White VII shallow bowl with flat, raised base; curved sides; flat, sloping rim. Diam. 13.5. Surface layer.
3. Coarse, depressed jug with round base; wide neck, tapering upwards; annular rim; handle from rim to shoulder. Height 18.0. Dromos filling.
4. Plain White VII oval jug with flat base; short, narrow neck; splaying mouth; handle from rim to shoulder. Height 17.0. Dromos filling.
5. White Painted VII amphoriskos with pointed base; curved outline; concave neck; splaying mouth; handle from rim to shoulder. Encircling band around belly; vertical bands from rim to base. Height 13.2. Dromos filling.
6. Circular bronze mounting with convex upper side; pierced through centre. Not complete. Diam. 3.3. Floor.
7. Fragments of a Coarse jug. Floor.
8. Coarse jug, as No. 3. Part of neck and handle missing. Height 12.0. Floor.
9. Plain White VII conical amphora with knobbed base; depressed shoulder; long, cylindrical neck; annular rim; handles from neck to shoulder. Height 81.0. In front of door-packing.

C h a m b e r.

10. Shallow terracotta lamp with flattened base; pinched wick-holder. Length 9.3. Floor.
11. Plain White VII oval, sack-shaped jug with flat base; concave neck; splaying rim; handle from rim to shoulder. Height 13.2. Floor.
12. Plain White VII oval jug with foot; slightly depressed shoulder; narrow neck; flat rim; twin-handle from neck to shoulder with side-knobs at neck and two projecting

knobs on either side of handle on shoulder. Height 34.0. Floor.

13. Bichrome VII oval jug, shape as No. 12. Encircling black and red lines and bands around body, shoulder, and neck; around shoulder, band of short, vertical, thin lines with dots in their interstices; pendent strokes from base of neck around shoulder. Height 46.0. Floor.
14. Plain White VII jug, as No. 12. Height 33.3. Floor.
15. Plain White VII oval jug with flat, raised base; depressed shoulder; wide, concave neck; stilted rim; handle from rim to shoulder. Height 24.3. Floor.
16. Fragment of alabastron. Floor.
17. Plain White VII sack-shaped jug with flat base; spindle-shaped body; concave neck; splaying rim. Height 13.5. Floor.
18. White Painted VII jug; shape as No. 12, but with moulded foot and rim. Metal imitating shape. Encircling bands around belly and shoulder; broad, latticed band around lower part of body and neck; below shoulder a frieze of running spirals. Decoration much worn. Height 48.5. On infiltrated earth.
19. Pair of earrings of gilded bronze. Diam. c. 2.0.
20. Plain White VII jug, as No. 12; but without projections at base of handle. Height 28.5. Floor.
21. Plain White VI sack-shaped jug with flat base; concave neck; splaying rim; slightly raised handle from rim to shoulder. Height 12.8. Floor.
22. Alabastron; one side corroded. Height 23.0. Floor.
23. Plain White VI shallow bowl with flat base; curved sides; plain rim. Part of side missing. Diam. 12.8. Floor.
24. Pair of gilded earrings of bronze. Diam. c. 2.0. Floor.
25. Pigment-rod of bronze with both ends thickened. Length 13.0. Floor.
26. Various fragments of iron, among which a) slightly curved rod with straight ends, which might be a handle to a sarcophagus; b) fragment of iron rod ending with

- a crossbar; c) fragments of iron nails; large heads. Length of a) 17.0; b) 8.0. Floor.
27. Coarse jug, as No. 3. Height 15.5. Floor.
 28. Small fragments of a bronze strigil of usual type. Floor.
 29. Shallow terracotta lamp with pinched wick-holder; some marks on the base indicate that the lamp was attached to a foot. Length 11.3. Floor.
 30. Shallow terracotta lamp with pinched wick-holder; shaved base. Length 10.7. Floor.
 31. Plain White VII squat jug with flat, raised base; concave neck; stilted rim; handle from rim to shoulder. Height 8.5. Ledge.
 32. Two bronze nails with square section; round, flat head. Length 7.2; 5.0. Floor.
 33. Plain White VII jug, as No. 11. Height 12.8. Floor.
 34. Bronze coin; illegible. Ledge.
 35. Plain White VII jug, as No. 11. Height 14.0. Ledge.
 36. Coarse, oval jug with flat base; gently curved, concave neck; plain rim; handle from rim to shoulder. Height 28.2. Ledge.
 37. Plain White VII oval amphora with knobbed base; bulging sides; slightly concave neck; flat, somewhat moulded rim; handles from neck to shoulder. Height 68.0. On infiltrated earth.
 38. Plain White VII jug, as No. 11. Part of side missing. Height 11.0. Floor.
 39. Plain White VI oval jug with flat base; gently curved outline; concave neck; plain rim; handle from neck to shoulder. Height 13.7. Floor.
 40. Coarse jug, as No. 3. Height 12.5. Floor.
 41. Coarse, sack-shaped jug, as No. 11. Height 11.0. Floor.
 42. Coarse, shallow bowl with flat base; flat rim. Diam. 12.8. Floor.
 43. Shallow terracotta lamp with shaved base; pinched wick-holder. Length 11.2. Floor.
 44. Terracotta lamp, as No. 10. Length 10.3. Floor.
 45. Plain White VII jug, as No. 11. Height 15.3. Floor.
 46. Terracotta lamp, as No. 43. Length 10.3. Floor.
 47. White Painted VII jug, as No. 18. Encircling band around belly and neck; decorations much worn. Height 43.0. In the filling.
 48. Plain White VII jug, as No. 15. Lower part missing. Height 28.0. In the filling.
 49. White Painted VII hydria with raised base-ring; rather biconical body; cylindrical neck; annular rim; vertical handle from neck to shoulder; horizontal handles on shoulder. Encircling lines and bands around body, shoulder, and neck; wavy band around body; three pendent strokes as front ornament on shoulder opposite vertical handle; band along vertical handle with three strokes at base of handle on shoulder; a stroke on either side of horizontal handle on shoulder. Height 43.0. In the filling.
 50. Terracotta lamp, as No. 10. Length 11.0. In the filling.
 51. Plain White VII shallow bowl with flat base; slightly curved sides; slightly swollen rim. Diam. 12.0. Floor.
 52. Plain White VII depressed oval jug with flat, raised base; narrow, concave neck; handle from neck to shoulder. Mouth missing. Height 14.5. Floor.
 53. Strigil of iron with curved blade, semicircular in section, fitted to a horizontal loop-handle, attached to the blade by a small, leaf-shaped mounting. Part of loop-handle and blade, end of blade missing. Length c. 26.0. Floor.
 54. Terracotta lamp, as No. 10. Part of rim missing. Length 9.5. Floor.
 55. Plain White VI shallow bowl with small, flat base; curved sides; plain rim. Diam. 12.4. Floor.
 56. Terracotta lamp, as No. 43. Length 10.0. Floor.
 57. Bronze nail with circular head; pointed end missing. Length c. 8.0. Floor.
 58. Plain White VII bowl with small, flat base; curved sides; somewhat contracted rim. Diam. 11.8. Floor.

The distribution of the finds is shown by the following diagram:

	Pottery					Iron			Bronze					Terracotta	Alabaster	
	Wh. P. VII	Bichrome VII	Pl. Wh. VI	Pl. Wh. VII	Coarse Ware	Rod	Strigil	Nail	Pigment-rod	Strigil	Earring	Mounting	Nail	Coin	Lamp	Bottle
Dromos	5			1, 2, 4, 9	3, 7, 8							6				
	-1			-4	-3							-1				
Chamber	18	13	21	11, 12, 14, 15	27, 36	26 a	53	26 c	25	28	19		32	34	10, 29, 30	16, 22
	+7		23	17, 20, 31, 33	40, 41	26 b					24		57		43, 44, 46	
	49		39	35, 37, 38, 45	42										50, 54, 56	
			55	48, 51, 52, 58												
	-3	-1	-4	-16	-5	-2	-1	-1	-1	-1	-2		-2	-1	-9	-2

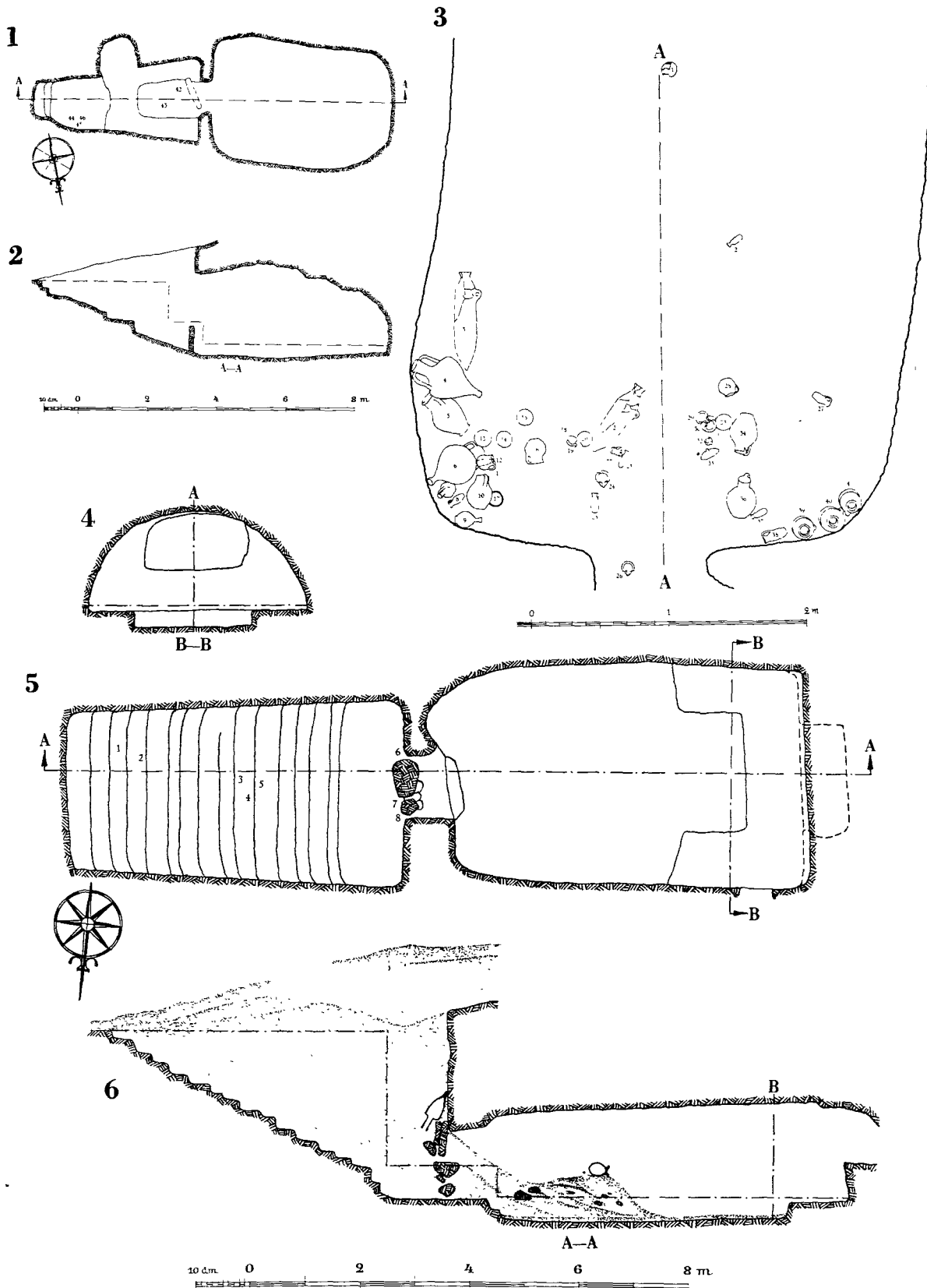

Fig. 172. Vouini. Tomb 7, Plan (1); Section (2); Finds *in situ* (3). Tomb 8, Plan (5); Sections (4, 6).

CHRONOLOGY

The pottery of this tomb indicates that the tomb definitely should be dated to the Cyprian Classic II period, as practically all the pots were of Type VII.

TOMB 9 (Fig. 173: 2—4)

	SIZE		
	Length	Width	Height
Dromos	6.60	2.10	3.00
Stomion	0.60	0.80	—
Chamber	5.90	4.00	2.80

SHAPE

This tomb, situated close to the previous one, is of a similar type. The dromos is somewhat longer and widens gently towards the stomion. The sides are perpendicular, and the floor is provided with a flight of seventeen steps. The stomion is well marked and strengthened by orthostatic jambs. The lintel, belonging to the doorway was found fallen down in the chamber. The doorway was blocked up by a large, raised slab. The chamber is roughly rectangular in shape, and has a floor on a somewhat lower level than the stomion floor. In the middle, there is a rectangular depression. The roof is barrel-shaped and like that in Tomb 8. A part of it, near the entrance has collapsed. In the S. corner, the chamber is slightly irregular. This is apparently due to the close vicinity of the chamber of Tomb 8. Most likely the workman who excavated the tomb noticed that he would come into this tomb unless he changed the direction of the wall. The wall between the two tombs is only about 0.30 m. thick. Tomb 9 had been looted and the tomb-robbers had entered through the doorway. It was easy to break through the wall into Tomb 8 which thus was visited. Fig. 173, 3 indicates the different floor-levels of the two tombs.

STRATIFICATION

The dromos filling, consisting of light-grey earth, was found dug through near the entrance. Evidently the tomb-robbers went down in a shaft there. The chamber contained some debris from the fallen portions of the roof and earth infiltrated from the dromos. The interior of the chamber, however, was quite empty.

BURIALS

Nothing could be ascertained as to the burials of this tomb. The vases, Nos. 1—3, found along the left side must belong to the original burials while the lamp, No. 4, possibly was left behind by the tomb-robbers.

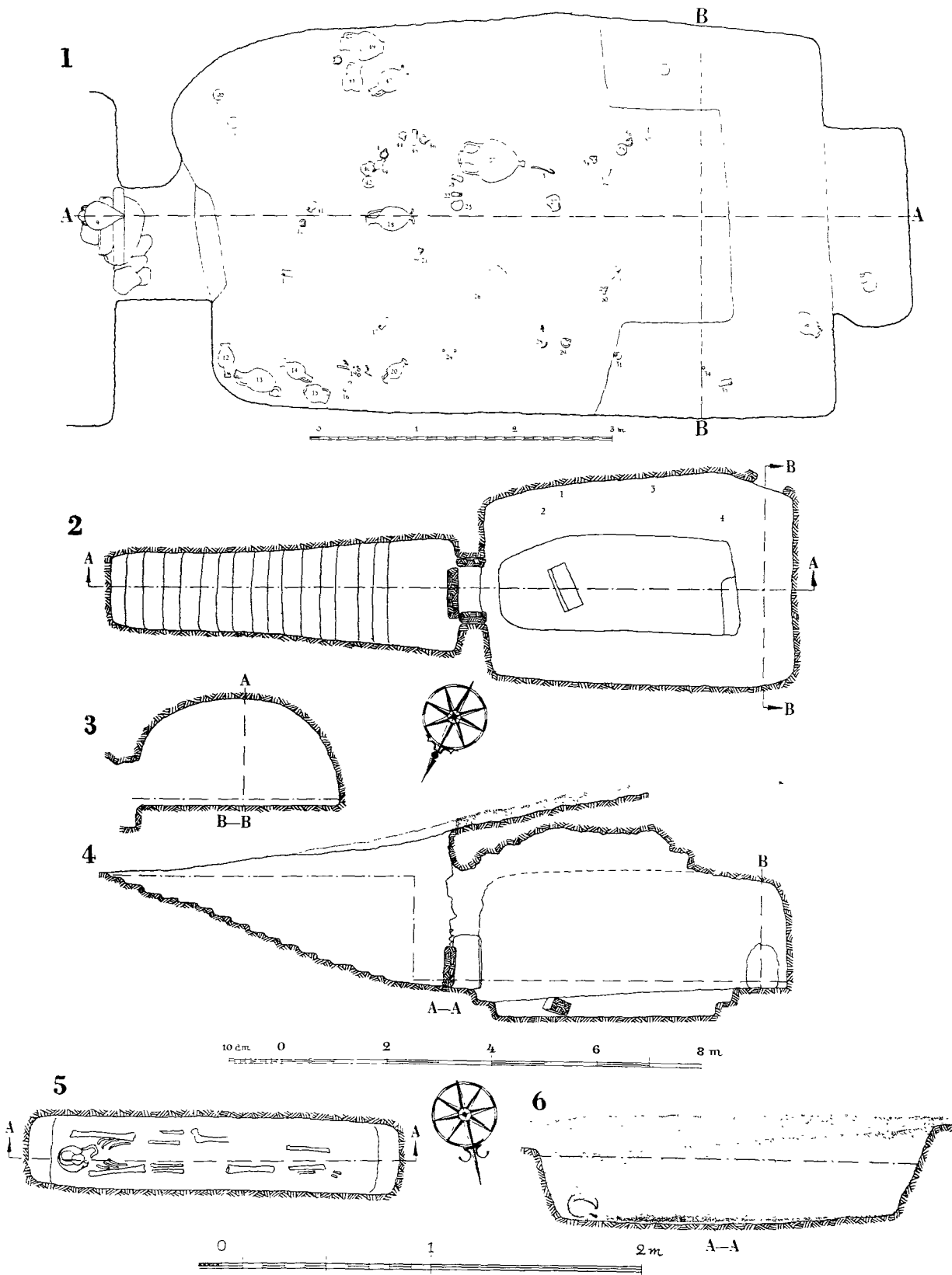

Fig. 173. Vouni. Tomb 8, Finds *in situ* (1). Tomb 9, Plan (2); Sections (3, 4). Tomb 10, Plan (5); Section (6).

FINDS (PL. CVI, I)

- | | |
|--|--|
| 1. Plain White VII pointed amphora with knobbed base, angular shoulder; cylindrical neck; moulded, sloping rim; handles from neck to shoulder. One handle missing. Height 84.0. Floor. | 3. Plain White VII sack-shaped jug with flat base, gently curved body and neck, splaying rim; handle from rim to shoulder. Height 14.6. Floor. |
| 2. Plain White VII pointed amphora with knobbed base, rounded shoulder line, concave neck; flat, slightly out-turned rim; handles from neck to shoulder. Height 60.5. Floor. | 4. Moulded terracotta lamp with flat base; volute nozzle, pierced, vertical handle, concave disc decorated with a bird sitting on a branch, kymation on edge; incised line on handle. Length 9.0. Floor. |
| | 5. Plain White VII amphora, as No. 2. Fragmentary. |

CHRONOLOGY

As all the vases are of Pl. Wh. VII Ware the tomb is definitely to be dated to the Cypro-Classic II period and rather to a late part of it, in consideration of the fact that the tomb must have been excavated in the rock later than Tomb 8. The Roman lamp, No. 4, may indicate the date of the looting of the tomb.

TOMB 10 (Figs. 171; 173: 5, 6)

The tomb consists of a narrow shaft excavated in the rock. On the bottom a skeleton was found in dorsal position very much pressed together between the sides of the shaft which, at the bottom, is no more than 0.25 m. wide. This burial may have some connexion with either Tomb 7 or 11 between which it is situated. It may be a sacrificial burial of a slave, killed when his master was buried in one of the tombs mentioned.

TOMB 11 (Figs. 176: 1—3, 5; 180)

SIZE

	Length	Width	Height
Dromos	4.80	1.55	2.65
Stomion	0.45	0.95	1.75
Chamber	4.00	3.15	2.30

SHAPE

This tomb is of a fairly regular type. The dromos widens gently towards the stomion. It is rather steep and before it reaches the stomion level three steps are noted. The sides are perpendicular. The lower parts of the stomion are well preserved with marked outline. The original door-packing was not found *in situ* but instead, some secondary rubbles were placed in the middle of the doorway. The chamber, rectangular in shape, is very regular with distinct corners. The lower parts of the sides are vertical; the upper portions, with the roof were destroyed.

STRATIFICATION

The tomb had been re-used for a burial in a subsequent period. This was clear from the conditions found in the chamber. Through the original dromos-filling consisting of grey

Fig. 174. Vouni. Tomb 7. Finds *in situ*.

Fig. 175. Vouni. Tomb 8. Rear wall of the chamber.

earth and *chavara*-stuff, a shaft had been dug and the door-packing removed. The original burial earth covered the floor, but about 0.50 m. above it, a second floor had been prepared in order to receive the second burial. Through the carelessly blocked-up door-packing, a certain amount of earth had come from the dromos.

BURIALS

The bottom layer of the chamber contained very few remains of skeletons indicating how the corpses were buried. In the middle, parts of two femora were preserved *in situ*. The burial-gifts belonging to this stratum are Nos. 9, 13—25. Possibly these should be ascribed to two different burials judging by the conditions in the dromos, where two different groups of vases were noted, one in the middle, Nos. 1—5, and another just in the beginning of it, Nos. 6—8. The second burial was intact though the skeleton had decayed badly. The corpse had been placed in dorsal position with the head to the S. Some finds were made in connexion with this burial (Nos. 10—12).

FINDS (PLS. CV, 3, CVI, 2)

Dromos.

1. Plain White VII biconical amphora with pointed base; angular outline; wide rim; vertical handles below shoulder. Height 52.0. Dromos filling.
2. Plain White VII oval jug with base-ring; gently curved neck; out-turned rim; handle from rim to shoulder. Fragmentary. Dromos filling.
3. Plain White VII hydria with gently curved shoulder; cylindrical neck; annular rim; horizontal handles on shoulder; vertical handle from neck to shoulder. Lower part missing. Height 32.0. Dromos filling.
4. Coarse, biconical jug with flat base; wide, curved neck; plain rim; handle from rim to shoulder. Part of neck missing. Height 11.0. Dromos filling.
5. Plain White VII torpedo-shaped pithos with pointed base; parallel sides; convex shoulder; squat lower portion; handle below shoulder; neck and rim missing. Height 59.0. Dromos filling.
6. Fragments of a Plain White VII jug. Dromos filling.
7. Plain White VII conical amphora with knobbed base; angular shoulder; long, cylindrical neck; annular rim; handles from upper part of neck to shoulder. Height 78.5. Dromos filling.
8. Plain White VII shallow bowl with flat base; curved sides; inturned rim. Diam. 11.0. Dromos filling.

Chamber.

- 9. Plain White VI-VII miniature jug with flat base; biconical body; narrow neck; stilted rim; handle (missing) from rim to shoulder. Height 5.6. +55.
- 10. Moulded terracotta lamp. -60.
- 11. Bronze coin. *Obverse*: Narrow-necked amphora; small, curved handles; around, inscription worn, similar to So 45. *Reverse*: Cut wine branch with two separate pendrils around, inscription worn, similar to So. 45. Diam 17. Weight 1.7. -60.
- 12. Bowl of glass with rounded base with small cavity in the centre; wide neck with angular rim. Diam. 6.5. -60.
- 13. Fragment of alabaster aryballos. Height 5.8. -10.
- 14. Shallow terracotta lamp with flat base; pinched wick-holder. Length 12.0. +22.
- 15. Bell-shaped lid of terracotta ending with a bird's head. Alternating black and red vertical lines. Height 8.0. -12
- 16. White Painted VII oval jug with flat base; gently curved neck; splaying rim; handle from rim to shoulder; short spout on shoulder and opposite the handle. Encircling

- lines around body and neck; on shoulder vertical stroke transverse lines on handles. Height 12.0. +16.
- 17. Plain White VII shallow bowl with small flat base; gently curved sides; slightly out-turned rim. Diam. +17.
- 18. Coarse, oval jug with flat base; wide, concave neck; plain rim; handle from rim to shoulder. Height 18.0. -20.
- 19. Plain White VII depressed, oval jug with flat base; narrow neck; handle from neck to shoulder. Rim missing. Height 15.5. -20.
- 20. Spiral-shaped hair-ring of silver with overlapping ends. Incised lines around ends. Diam. 1.1.
- 21. Plain White VI sack-shaped jug with flat base; spindle-shaped body; concave neck; splaying rim; handle from rim to shoulder. Height 16.0. -30.
- 22. Plain White VI jug with flat base; concave neck; plain rim; slightly raised handle from rim to shoulder; short spout on shoulder opposite the handle. Height 9.8. -25.
- 23. Shallow terracotta lamp, as No. 14, but with shaved base. Length 11.5. -10.
- 24. Terracotta lamp, as No. 14. Length 9.5. +25.
- 25. Fragments of a bronze mirror. +25.

The distribution of the finds is shown by the following diagram:

	Pottery					Bronze	Silver	Terracotta		Glass	Alabaster	
	Wh. P. VII	Pl. Wh. VI	Pl. Wh. VII	Pl. Wh. VI-VII	Coarse Ware	Mirror	Coin	Hair-ring	Lid	Lamp	Bowl	Bottle
Dromos			1, 2, 3, 5, 6, 7, 8 -7		4 -1							
Chamber 1st burial layer	16 -1	21, 22 -2	17, 19 -2	9 -1	18 -1	25 -1		20 -1	15 -1	14, 23 24 -3		13 -1
Chamber 2nd burial layer						11 -1				10 -1	12 -1	

CHRONOLOGY

The pottery of the dromos and the first burial layer consist of White Painted VII, Plain White VII, and two specimens of Plain White VI Wares and a jug of Coarse Ware. In consequence of this, the burial of this period should be dated to the Cypro-Classic II period. The date of the second burial period ought to be fixed in accordance with the coin, No. 11. This is a Maccabaeian coin dating from the first revolt in 66—70 A. D. The date of the burial may therefore be fixed to the end of the 1st Century A. D.

TOMB 12 (Figs. 176: 4; 177; 179: 1—3; 181)

SIZE

	Length	Width	Height
Dromos	4.25	1.70	2.75
Stomion	0.90	0.75	1.00
Chamber	4.10	4.00	1.75

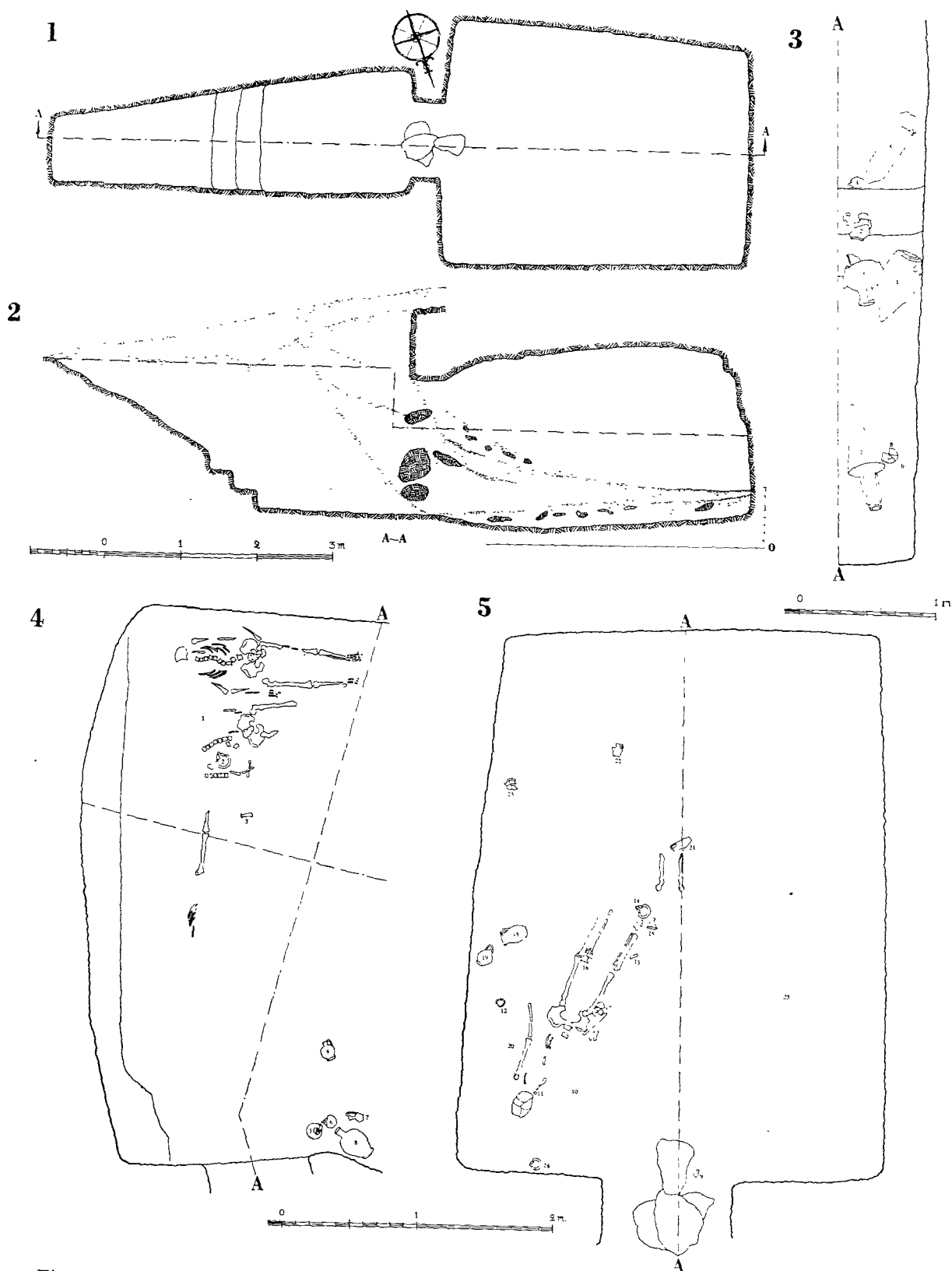

Fig. 176. Vouni. Tomb 11, Plan (1); Section (2); Finds *in situ* (3, 5). Tomb 12, Finds *in situ* (4).



Fig. 177. Vouni. Tomb 12. Dromos.



Fig. 178. Vouni. Tomb 14. Dromos.

SHAPE

Tombs 8 and 9 are situated on the top of the necropolis hill. In a row below, Tombs 12—15 are arranged along the side of the hill. They are all of minor size and fairly similar in construction. Tomb 12 is the easternmost of them. It is provided with a steep dromos with eight steps and perpendicular sides. The lowest step is continued on the sides of the dromos as in other tombs. The stomion is rectangular in shape and was blocked up by a loose packing consisting of irregular rubble. Evidently there was no damage caused to it in subsequent periods. The chamber is almost square in shape with one corner rounded. It is not aligned with the dromos axis but turned to the right. This is most likely due to a hard portion of rock met with on the left, which made the excavating difficult. The tomb had a low barrel-vault starting from the floor.

STRATIFICATION

The dromos-filling consisted of intact homogeneous earth. The conditions in the chamber were very simple. A large piece of the roof had fallen down and the rock stuff was found in a heap in the middle of the tomb. With exception of some earth infiltrated from the dromos there was no earth in the tomb other than the thin burial earth on the bottom.

BURIALS

Remains of at least four skeletons could be distinguished in the chamber. Three of them had been placed in the inner, left corner and were found without any earth above them (Fig. 181). In close vicinity of these skeletons, a strigil (No. 1), a lamp (No. 2), and an alabastron (No. 3) were found. The pottery was gathered in a small deposit to the right, just inside the entrance. Besides the group of three skeletons mentioned, there are also remains of a fourth one, to the E. of them. Only a femur and some ribs were preserved. This corpse had been placed in a different direction.

FINDS (PL. CVII, 1)

- | | |
|---|---|
| 1. Bronze strigil. Length 13.0. Floor. | what raised handle from rim to shoulder. Height 15.0. Floor. |
| 2. Shallow terracotta lamp with shaved base; pinched wick-holder. Length 14.0. Floor. | 6. Terracotta lamp, as No. 2. Length 11.5. Floor. |
| 3. Juglet of alabaster; side-knobs. Floor. | 7. Plain White VI jug with base-ring; depressed shoulder; narrow neck; pinched rim; raised handle from rim to shoulder. Height 12.4. Floor. |
| 4. Plain White VI oval jug with wide base-ring; narrow neck; annular rim; raised handle from rim to shoulder. Height 14.0. Floor. | 8. Plain White VI oval jug with base-ring; depressed shoulder; narrow, cylindrical neck; annular rim; twin-handle from rim to shoulder. Height 29.0. Floor. |
| 5. Plain White VI depressed jug; base missing; gently curved body and neck; slightly pinched rim; some- | |

The distribution of the finds is shown by the following diagram:

Pottery	Bronze	Terracotta	Alabaster
Pl. Wh. VI	Strigil	Lamp	Bottle
4, 5, 7, 8 -4	1 -1	2, 6 -2	3 -1

CHRONOLOGY

As all the pottery consisted of Plain White VI Ware the tomb should be dated to the Cypro-Classic I period.

TOMB 13 (Figs. 179: 4—6; 182: 1)

SIZE

	Length	Width	Height
Dromos	3.85	1.50	2.75
Stomion	0.70	0.80	1.20
Chamber	2.40	2.90	1.65

SHAPE

The dromos of this tomb is of practically the same shape as that in Tomb 12. The stomion is well preserved, rectangular in shape. In plan it widens towards the chamber. This is rather indistinct in outline and has rounded corners. The roof, barrel-vaulted, is perfectly preserved.

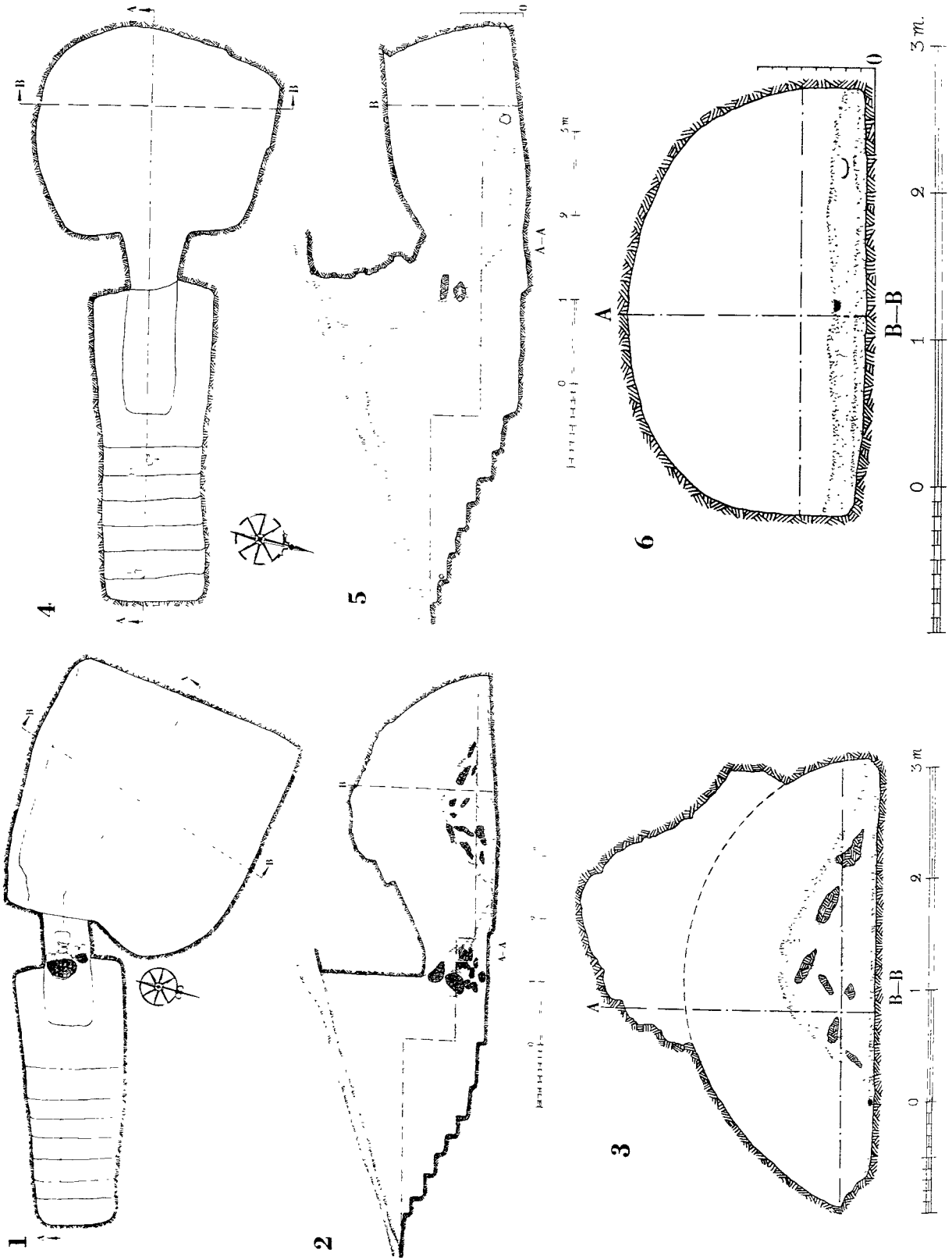

Fig. 179. Vounji Tomb 15. Plan (1). Section (2). Section (3). Section (4). Section (5). Section (6).



Fig. 180. Vouni. Tomb 11. Skeleton *in situ*.



Fig. 181. Vouni. Tomb 12. Skeletons *in situ*.

STRATIFICATION

The tomb had been visited by robbers who had dug a shaft close to the front wall of the dromos and destroyed the door-packing. Through this shaft a certain amount of earth had come into the chamber and covered the whole floor with the original burial layer on the bottom.

BURIALS

The interior of the chamber was found in an entire disorder, due to the looting of the tomb. Nothing could be ascertained as to the arrangement of the burials. A fragment of a skull was found close to the right wall and some other skeletal remains were scattered about in the same part of the tomb. A small group of vases were found in the intact part of the dromos.

FINDS (PL. CVII, 2,3)

D r o m o s.

1. Plain White VI sack-shaped jug with flat base; oval body; concave neck; plain rim; slightly raised handle from rim to body. Height 12.5.
2. Plain White VI shallow bowl with flat base; curved sides; somewhat out-turned rim. Diam. 10.0.
3. Fragment of a Plain White VI bowl, as No. 2.
4. Plain White VI jug, as No. 1. Handle missing. Height 13.0.

C h a m b e r.

5. Plain White VII sack-shaped jug with flat base; clumsy body; concave neck; splaying mouth; handle from rim to shoulder. Height 12.5. -20.
6. Plain White VII jug, as No. 5. Height 12.5. -20.
7. Shallow terracotta lamp; shaved base; pinched wick-holder. Length 11.0. Floor.
8. White Painted VI bowl with flat base; curved sides; plain rim. Encircling lines inside. Diam. 12.0. Floor.
9. Terracotta lamp, as No. 7, but with flat base. Length 11.5. Floor.
10. Plain White VI jug, as No. 1. Height 12.0. -15.
11. Terracotta lamp, as No. 9. Length 12.0. Floor.
12. Terracotta lamp, as No. 9. Length 12.0. Floor.
13. Terracotta lamp, as No. 9. Length 9.0. Floor.
14. Plain White VII globular jug with base-ring; tubular neck; stilted rim; angular twin-handle from neck to shoulder. Height 20.0. Floor.
15. Coarse jug with depressed body; round base; wide out-turned rim; handle from rim to shoulder. Height 14.0. Floor.
16. Plain White VII bowl with flat base; curved sides out-turned rim. Diam. 12.0 -18.
17. Plain White VII bowl, as No. 16. Diam. 13.5. -23
18. Coarse jug with rounded base; depressed body; concave neck; plain rim; handle from rim to shoulder. Height 14.0. -15.
19. Terracotta lamp, as No. 7. Length 11.0. -10.
20. Terracotta lamp, as No. 9. Length 11.0. -12.
21. Plain White VII sack-shaped jug with flat base; spindle-shaped body; splaying rim; handle from rim to shoulder. Height 17.0. -28.
22. Bichrome Red IV (VII) jug with wide, raised base-ring; oval body; cylindrical neck; splaying mouth; twin-handle from neck to shoulder with side-knobs at neck. Encircling black and white lines around body and neck; white frieze of palmettes on shoulder; black and white dotted line around neck. Height 25.0. -20.0.
23. Plain White VII oval jug with flat base; concave neck; stilted rim; handle from rim to shoulder. Height 24.0. -20.
24. Coarse jug, as No. 18, but with flat base. Height 14.0. -17.
25. Coarse jug, as No. 18. Height 20.0. -12.
26. Scarab of dark stone; rough technique; on base, buck turned left Length 15 Floor
27. Terracotta lamp, as No. 9. Length 9.0. Floor.

The distribution of the finds is shown by the following diagram:

	P o t t e r y						Terracotta	Glyptics
	Wh. P. VI	Bichrome Red IV (VII)	Pl. Wh. VI	Pl. Wh. VII	Coarse Ware		Lamp	Scarab
Dromos			1, 2, 3, 4 -4					
Chamber	8	22	10	5, 6, 14 16, 17, 21 23	15, 18, 24 25	7, 9, 11 12, 13, 19 20, 27 -8	26	-1
	-1	-1	-1	-7	-4			

CHRONOLOGY

The pottery found in the tomb consisted of White Painted VI, Bichrome Red IV (VII), Plain White VI and VII, and Coarse Wares. The Plain White VII Ware is in majority and the tomb, consequently, should be dated to the Cypro-Classic II period.

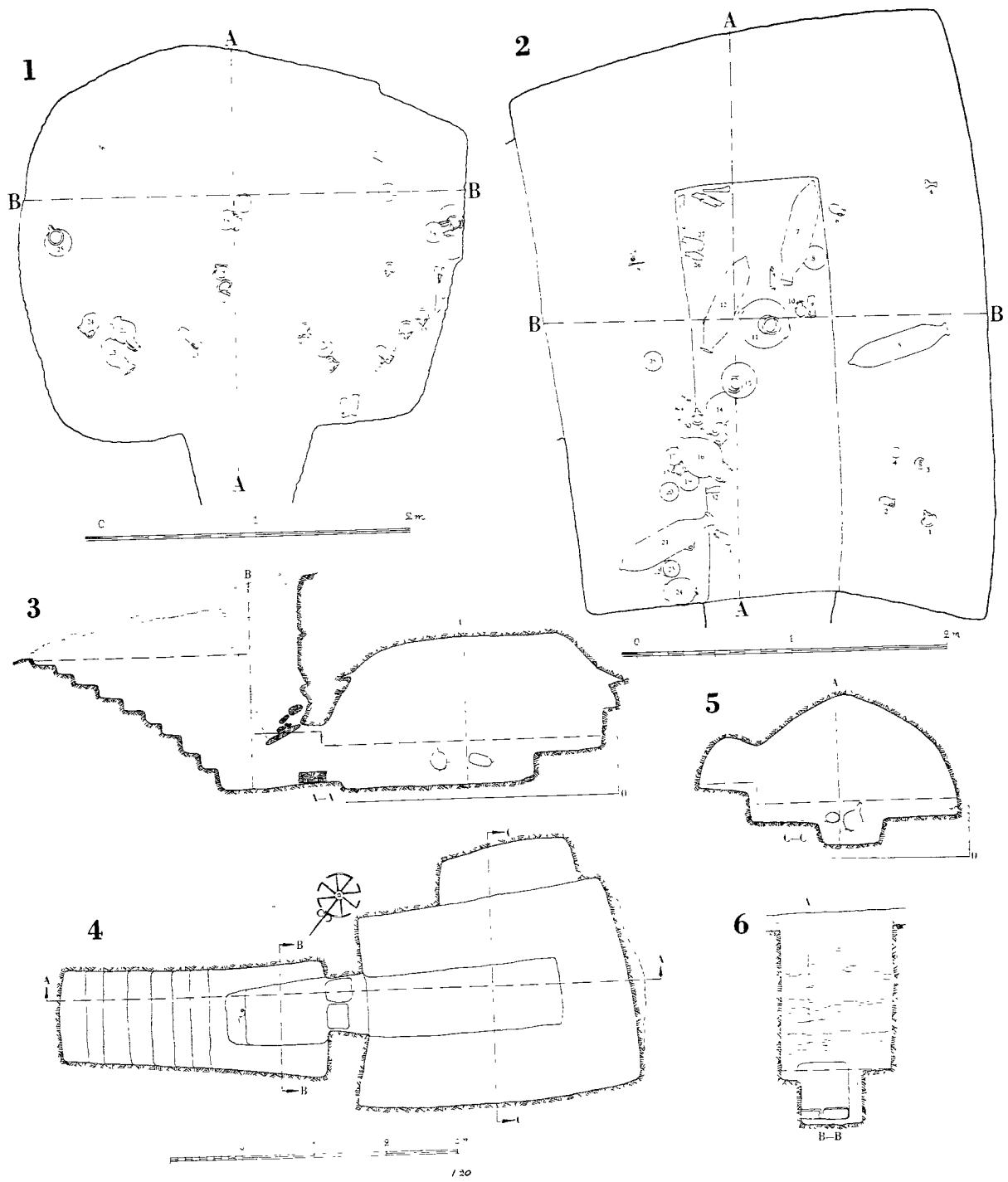

Fig. 182. Vouni. Tomb 13, Finds *in situ* (1). Tomb 14, Finds *in situ* (2); Plan (4); Sections (3, 5, 6).

TOMB 14 (Figs. 178; 182: 2—6; 183; 184)

SIZE

	Length	Width	Height
Dromos	3.70	1.60	2.90
Stomion	0.55	0.80	0.80
Chamber	3.70	2.90	2.00

SHAPE

This tomb has a dromos of the same shape as the previous two tombs. The steps, here ten in number, are very distinct and well preserved. The stomion is placed somewhat off the middle axis. It is rectangular in shape and well preserved with a threshold in position. The chamber is rectangular in shape though three of the walls are not quite straight. In the middle there is an oblong depression which starts inside the entrance and extends to about 0.95 m. from the rear wall. The roof is made like a somewhat pointed barrel-vault, which starts from the floor. A wide niche was begun in the rear wall but possibly the large cracks in the rock on this side made the cutter stop his work.

STRATIFICATION

The earth in the dromos was very light in colour. Originally it was homogeneous but tomb-robbers had dug a shaft just above the entrance through which they had entered the tomb. The chamber contained earth infiltrated from the dromos but only in the depression in the floor.

BURIALS

The tomb-robbers had spoilt all evidence as to the position of the burials. They had thrown most of the tomb-gifts in a heap in the middle of the tomb and none seemed to remain *in situ*. Among the vases some skeletal fragments could be noted.

FINDS (PLS. CVII, 4; CVIII, 1)

1. Shallow lamp of terracotta with pinched wick-holder; rounded, shaved base. Length 11.0. — 32.
2. Plain White VII oval sack-shaped jug with flat base; concave neck; plain rim; handle from rim to shoulder. Height 9.5. — 32.
3. Plain White VII depressed jug with flat base; sloping shoulder; splaying mouth; handle from neck to shoulder. Height 9.0. — 35.
4. Red Figured lekythos with flat base; depressed body; narrow neck; large, funnel-shaped mouth with flat rim; handle from neck to shoulder. Female figure as front ornament; the woman holds a flower above an altar, the dress roughly indicated by black lines. Height 13.0. — 38.
5. Plain White VII torpedo-shaped pithos; parallel sides; gently curved shoulder and neck; stilted rim; vertical handle below shoulder. Height 67.0. — 38.
6. Plain White VII jug, as No. 2. Height 10.0. — 50.
7. Plain White VII pithos, as No. 5. The pithos was closed by a gypsum lid. Height 67.0. — 40.
8. Plain White VII plate with small base-ring; straight sides; wide, flat, horizontal rim. Diam. 16.0. — 40.
9. Plain White VII sack-shaped jug, as No. 2. Height 13.5. — 20.
10. Plain White VII biconical jug with flat base; gently curved neck; plain rim; handle from rim to shoulder; spout opposite handle on shoulder. Height 10.0. — 20.
11. White Painted VII oval hydria with raised base-ring; cylindrical neck; annular rim; vertical handle from neck to shoulder; two horizontal handles on body below shoulder. Encircling bands on belly, shoulder, and rim; rippled line around neck; short perpendicular strokes on upper part of shoulder; black painted handles. Height 30.0. — 38.
12. Plain White VII pithos, as No. 5. Height 67.0. — 42.

13. White Painted VII oval jug with flat base; gently curved neck; flat, moulded rim; handle from rim to shoulder. Encircling lines on shoulder and belly; wavy line around neck; three perpendicular strokes hanging on shoulder as front ornament. Decoration worn. Height 36.0. —40.
14. Bichrome Red IV (VII) jug with raised base-ring; oval body; depressed shoulder; cylindrical neck with moulded, flat rim; twin-handle from neck to shoulder with side-knobs. Encircling white and black lines around body and neck; on shoulder white lily stands with flowers spread over shoulder growing up from a horizontal, encircling line around body; on either side of each stem leaves; detached lily flowers on neck; crossed lines on side-knobs; black, vertical lines on handle. Height 30.0. —40.
15. Coarse, squat jug with round base; wide, concave neck; handle from rim to shoulder. Height 12.0. —40.
16. Plain White VII oval amphora with small, raised base-ring; gently curved outline; moulded rim; handles from neck to shoulder. Height 40.0. —40.
17. Plain White VII bowl, with flat base; plain rim. Diam. 12.5. —40.
18. Shallow terracotta lamp with flat base; pinched wick-holder. Length 11.0. —42.
19. Plain White VII bowl, as No. 17. Diam. 13.0. —44.
20. Plain White VII bowl, as No. 17. Diam. 13.0. —40.
21. Plain White VII torpedo-shaped pithos, as No. 7. Height 21.0. —50.
22. Plain White VII bowl, as No. 17. Diam. 11.0. —50.
23. Plain White VII bowl, as No. 17, but with slightly out-turned rim. Diam. 11.5. —52.
24. Plain White VII oval jug with wide, raised base-ring; neck and handle missing. Height 20.0. —45.
25. Plain White VII bowl, as No. 17. Diam. 13.5. —45.
26. Plain White VII jug, as No. 2. Rim and handle missing. Height 11.5. —25.
27. Plain White VII jug, as No. 26. Height 14.0. —27.
28. Fragment of iron knife. —50.
29. Circular finger-ring of bronze, circular in section. Diam. 2.0. —50.
30. Terracotta lamp, as No. 1. Length 11.0. —42.
31. Plain White VII jug, as No. 2. Height 13.0. —42.
32. Alabastron with somewhat rounded base; spindle-shaped body; moulded neck; wide, flat rim; side-knobs. Height 9.0. —32.
33. Plain White VII squat jug with flat base; concave neck; handle from rim to shoulder; short spout on shoulder opposite handle. Height 10.0. Dromos.

Supplementary Catalogue.

34. Plain White VII torpedo-shaped pithos, as No. 5. Painted inscription See Appendix IV. Height 67.0. Chamber.
35. Plain White VII pithos, as No. 5, but with squat base portion. Height 58.0. Chamber.

The distribution of the finds is shown by the following diagram:

P o t t e r y					Iron	Bronze	Terracotta	Alabaster
Wh. P. VII	Bichrome Red IV (VII)	Pl. Wh. VII	Coarse Ware	Red Figured Ware	Fragment	Finger-ring	Lamp	Bottle
11, 13	14	2, 3, 5, 6, 7, 8 9, 10, 12, 16, 17, 19 20, 21, 22, 23, 24, 25 26, 27, 31, 33, 34, 35	15	4	28	29	1, 18, 30	32
-2	-1	-24	-1	-1	-1	-1	-3	-1

CHRONOLOGY

The pottery consists of White Painted VII, Bichrome Red IV (VII), Plain White VII, and Coarse Wares. This combination of wares dates the tomb definitely to the Cypro-Classic II period. The date is confirmed by the Red Figured lekythos, No. 4, which displays traits characteristic of the period.

TOMB 15 (Fig. 185: 1—3)

SIZE

	Length	Width	Height
Dromos	4.10	1.40	2.55
Stomion	0.65	0.60	0.95
Chamber	2.35	1.70	1.75



Fig. 183. Vouni. Tomb 14. Interior view.



Fig. 184. Vouni. Tomb 14. Detail of a wall.

SHAPE

The tomb is remarkable because of the exceptionally small chamber. The dromos is comparatively large and provided with eight well defined steps. On the left side, there is a kind of ledge which possibly may be explained by the cutter having changed his original plan and made the dromos narrower. The doorway, rectangular in shape, was well closed by flat slabs laid on top of each other. The interior of the tomb is oblong; the corners gently rounded. The roof was probably somewhat curved but did not as in the other tombs start from the floor directly. There are vertical walls to about 1.20 m. above the floor. A large piece of the roof had fallen down on the floor.

STRATIFICATION

The dromos layers were intact and consisted of homogeneous, white earth. At about half-way down, a dark strip indicated the existence of a burial in the dromos (cf. below). In the chamber there was a heap of debris fallen from the roof, which had partly collapsed. The rock stuff was on top of some earth which had infiltrated through the door-packing from the dromos.

BURIALS

The tomb was intact. In the chamber no skeletal remains were preserved, but the deposit of burial-gifts had not been disturbed. Some vases, Nos. 1—3, were leaning against the right wall, while Nos. 6—7 were found in the left part. The mirror, No. 5, may indicate that a woman was buried in the tomb.

A skeleton was found in the dromos filling, lying in dorsal position with the head facing the entrance into the chamber. As to the level in the filling, see Fig. 185, 1.

FINDS (PLS. CVIII, 2; CIX, 1)

1. Plain White VI amphora with knobbed base; depressed, oval body; gently curved neck; profiled flat rim; handles from neck to shoulder. Painted inscription between handles on shoulder (See Appendix IV). Height 60.0. Floor.
2. Plain White VII torpedo-shaped pithos with pointed base; sides slightly tapering upwards; concave neck; annular rim; small handle below shoulder. Painted inscription on shoulder (See Appendix II). Height 69.0. Floor.
3. Plain White VII jug with flat base; gently curved body; concave neck; splaying rim; handle from rim to shoulder. Height 13.0. Floor.
4. White Painted VI depressed, oval hydria with base-ring; cylindrical neck; annular rim; horizontal handles on shoulder. Encircling lines and bands around body, shoulder, and neck; two wavy lines on shoulder; stroke on handle; three perpendicular strokes on shoulder, at base of handle. Height 43.5. Floor.
5. Bronze mirror with circular disc; tang widening upwards ending in a volute palmette. Diam. 13.5. Floor.
6. Coarse bowl with flat, raised base; curved sides; plain rim. Diam. 11.8. Floor.
7. Shallow terracotta lamp with flat base; pinched wick-holder. Length 10.0. Floor.

The distribution of the finds is shown by the following diagram:

P o t t e r y				Bronze	Terracotta	
Wh. P. VI	Pl	Wh. VI	Pl. Wh VII	Coarse Ware	Mirror	Lamp
4		1	2, 3	6	5	7
-1		-1	-2	-1	-1	-1

CHRONOLOGY

The pottery consists of Plain White VI and VII, and Coarse Wares. This combination of wares date the tomb to the beginning of the Cypro-Classic II period.

TOMB 16 (Fig. 185: 4—6)

SIZE

	Length	Width	Height
Dromos	3.80	2.20	2.25
Stomion	0.80	0.90	—
Chamber	5.40	4.00	—

SHAPE

The dromos is rectangular in shape and widens slightly towards the chamber. Six steps in the beginning of the dromos lead down to the threshold level of the stomion, which is well defined in plan but destroyed in the upper portions. The lower part of the door-pack- ing was preserved. The chamber is irregularly rectangular in shape. It widens somewhat towards the rear wall. The roof has partly collapsed so that the original height of the chamber cannot be determined.

STRATIFICATION

The chamber had been visited by tomb-robbers who had entered through the doorway. This explained the facts in the tomb, where most of the finds proved to have been removed from their original places. The tomb contained a great quantity of *chavara*-stone which covered the whole floor. In the dromos, however, the layers seemed to be intact.

BURIALS

As the conditions in the chamber were altered by the tomb-robbers and no skeletal remains were found there, it seems difficult to make any certain suggestions as to the original burial arrangements in the chamber. It may be pointed out, however, that the vases Nos. 1—3, which constitute an early group among the contents, were found rather high up in the filling where the vases were thrown by the robbers. They may possibly originate from the same place in the chamber, from an earlier burial than the rest of the objects, which were found more or less close on the floor. An intact deposit of vases was found in the dromos just outside the doorway. Here the vases, Nos. 16—20, were placed in upright position on the dromos floor. Apparently, if the suggestion of the two burial periods in the chamber is right, the dromos deposit should be connected with the later burial period.

FINDS (PL. CIX, 2,3)

C h a m b e r

1. Plain White VI shallow plate with flat base; straight sides; flat, horizontal rim. Diam. 14.0. — 55.
2. Plain White VI torpedo-shaped pithos with long, pointed base; marked shoulder line; small, vertical handle below shoulder; neck and rim missing. Painted inscription on shoulder (See Appendix IV). Height 64.0. — 50.
3. White Painted VI oval jug with curved foot; neck slightly tapering upwards; moulded, flat rim; twin-handle from neck to shoulder; figurine holding miniature vase on neck opposite the handle, and spout with moulded base below figurine on shoulder. Encircling lines and bands around foot, belly, shoulder, and neck; vertical strokes on foot; a latticed, dotted frieze around body; band of kymation below shoulder; trail of hanging and upright palmettes around shoulder, elongated, filled triangles around lower part of neck; broad, latticed band around upper part of neck; oblique strokes on handle. Part of spout and foot missing. Height 27.0. — 50.
4. Plain White VII sack-shaped jug. Height 16.0. — 15.
5. Shallow terracotta lamp with flat base; pinched wick-holder. Length 10.5. — 15.
6. Plain White VII sack-shaped jug with flat base; body tapering upwards; concave neck; handle from rim to shoulder. Height 13.0. — 25.
7. Terracotta lamp, as No. 5. Length 10.2. — 15.
8. Bronze fragments. — 12.
9. Horse-shoe shaped finger-ring of silver with triangular

section; large, oval bezel of blue glass; partly preserved filigree work at ends of bezel. Diam. 2.5. + 25.

10. Bronze coin, indecipherable. Diam. 1.5. + 20.
11. Horse-shoe shaped finger-ring of silver with oval bezel of iron; ring round in section. Diam. 2.3. + 25.
12. Crescent-shaped, thin earring of silver with line of impressed dots on edge. Diam. 1.7. + 25.
13. Plain White VII torpedo-shaped pithos with pointed base; parallel sides; gently curved shoulder and neck; annular rim; vertical handle below shoulder. Height 68.0. — 25.
14. Fragments of a bronze strigil. + 5.
15. Plain White VII oval jug with flat base; depressed shoulder; neck slightly tapering upwards; stilted rim; handle from rim to shoulder. Height 10.3. + 12.

D r o m o s.

16. Plain White VII torpedo-shaped pithos, as No. 13. Lower part missing. On shoulder painted inscription with Cypriote characters, (See Appendix IV). Height 45.5. + 130.
17. Plain White VII biconical jug with flat base; narrow neck; somewhat inturned rim; angular handle from rim to shoulder. Height 14.0. + 87.
18. Plain White VII bowl with flat base; curved sides; inturned rim. Diam. 13.5. + 87.
19. Coarse, squat jug with round base; wide, concave neck; plain rim; handle from rim to shoulder. Height 11.5. + 90.
20. Coarse jug, as No. 19. Height 9.8. + 125.

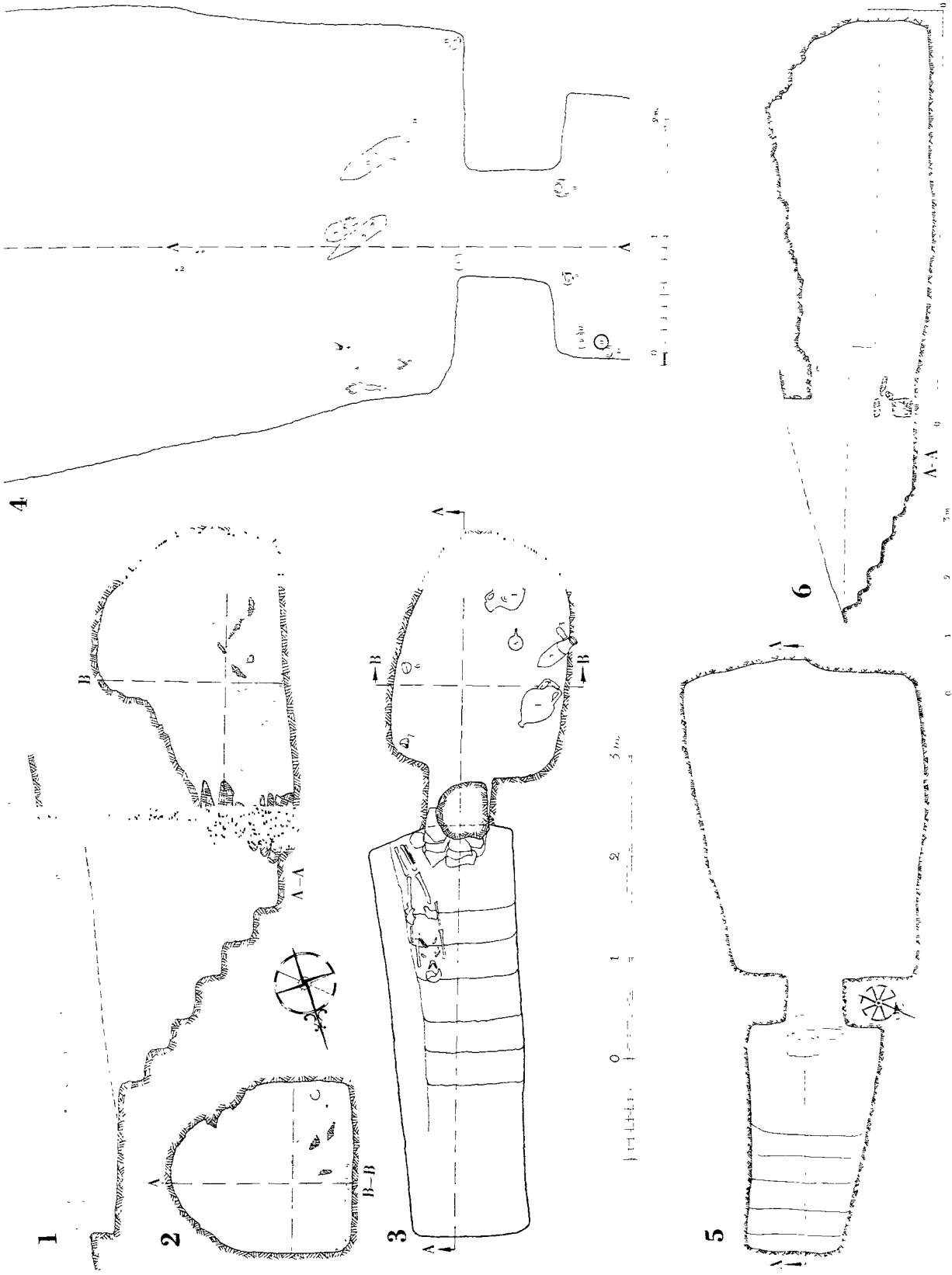

Fig. 185. Vouini. Tomb 16, Sections (1, 2); Plan with finds *in situ* (3); Tomb 16, Finds *in situ* (4); Plan (5); Section (6).

The distribution of the finds is shown by the following diagram:

	P o t t e r y				B r o n z e		S i l v e r		Terracot	
	Wh P. VI	Pl. VI	Wh VII	Pl. VII	Coarse Ware	Strigil	Coin	Earring	Finger-ring	Lamp
Dromos			16, 17, 18 -3		19, 20 -2					
Chamber	3 -1	1, 2 -2	4, 6, 13, 15 -4			14 -1	10 -1	12 -1	9, 11 -2	5, 7 -2

CHRONOLOGY

As has been suggested above there may have been two burial occasions distinguishable in the chamber. If this is right the vases, Nos. 1—3, should be ascribed to the earlier burial while the rest to the later one. The earlier group is represented by White Painted VI and Plain White VI Wares. This dates this burial to the Cypro-Classic I period. The later group is represented by Plain White VII and Coarse Wares. This combination of wares dates the later burial to the Cypro-Classic II period.

SUMMARY

With the exception of Tombs 5 and 10, which are of little interest, all the tombs display the same characteristics. A stepped dromos leads down to the doorway and the chamber, which is more or less rectangular in shape. In one case (Tomb 3) circumstances were noted which could be interpreted as a wooden floor on which the burials were made. The roofs in the tombs were barrel-vaulted. The doorways were blocked up by rubble as in Tomb 1, or by rubble and raised ashlar as in Tombs 4, 6, 8 etc., or by a wall of flat slabs, as in Tomb 15, or by a large, raised slab only, as in Tomb 9. Also the burial arrangement is generally the same in all these chamber-tombs. The corpses seem to have been buried in dorsal position on the floor. As a rule, they were placed to the right and left along the sides of the chambers, and the burial-gifts were generally placed near the entrance. Often the pithoi were leaning against the walls. In many cases (Tombs 1, 2, 3, 4, 8, 16), a deposit of vases was placed outside the entrance, too, in the dromos. Pithoi were put upside down so that one must draw the conclusion that an offering was made to the dead. The contents of the pithoi were poured out into the chamber after the doorway was blocked. Other offerings were also made in the dromos as is demonstrated by other vases found in the dromos filling, often near the beginning of the dromos.

As to the dating of the tombs it is noted that they are contemporary with the later part of the Palace period, or even still later. The pottery displays often traits which are not met with on the pottery found in the palace. Some of the later Type VII are still more advanced and point towards the subsequent, Cypro-Hellenistic pottery. Possibly the earliest tombs of Vouni were situated on the palace hill (cf. p. 82). Subsequently, when the building activity was going on all over the summit area, the necropolis was changed to the site of Korakas.

Evidently some of the tombs were opened in Roman times, Tomb 11 for receiving a

burial. Other tombs were in this time opened by tomb-robbers who had left behind them a lamp (in Tomb 9) which fixes the date of the occasion.

In order to facilitate the survey of the find groups, they are arranged as follows, showing their distribution between the different periods:

Cypro-Classic I: 12, 16 ^I	2
Cypro-Classic II A: 2, 3, 6, 13, 15	5
Cypro-Classic II B: 1, 4, 5, 7, 8, 9, 11 ^I , 14, 16 ^{II}	9
Cypro-Roman, 1st Cent. A. D: 11 ^{II}	1
	Total 17

A. W.



Fig. 186. Mersinaki. View of the shore, from the excavator's tent.

M E R S I N A K I

INTRODUCTION

The site of Mersinaki is situated near the shore half-way between Vouni and Soli, on the banks of a small river which comes down from the mountains above the village of Galini. There, between the hills below Vouni and the rocky ridge just W. of Soli, a triangular plain now called Mersinaki, has evidently silted up with sand and gravel from this river. In prehistoric times, there was probably a bay of the sea where now fertile fields rise a couple of metres above sea-level. At present, the river runs through the middle of the plain and falls into the sea in a small promontory or delta. The site is extremely attractive with its gigantic, old olive trees, and bushes of tamarisk and oleander. Near the middle of the plain, there are remains of a small church or chapel, almost hidden by vegetation. The place is called Ajia Varvara and peasants are still making their votive offerings there, bits of cloth, candles, etc. No other remains of buildings are visible on the surface, but hewn stones and some ashlar blocks are to be found in the low terrace walls in

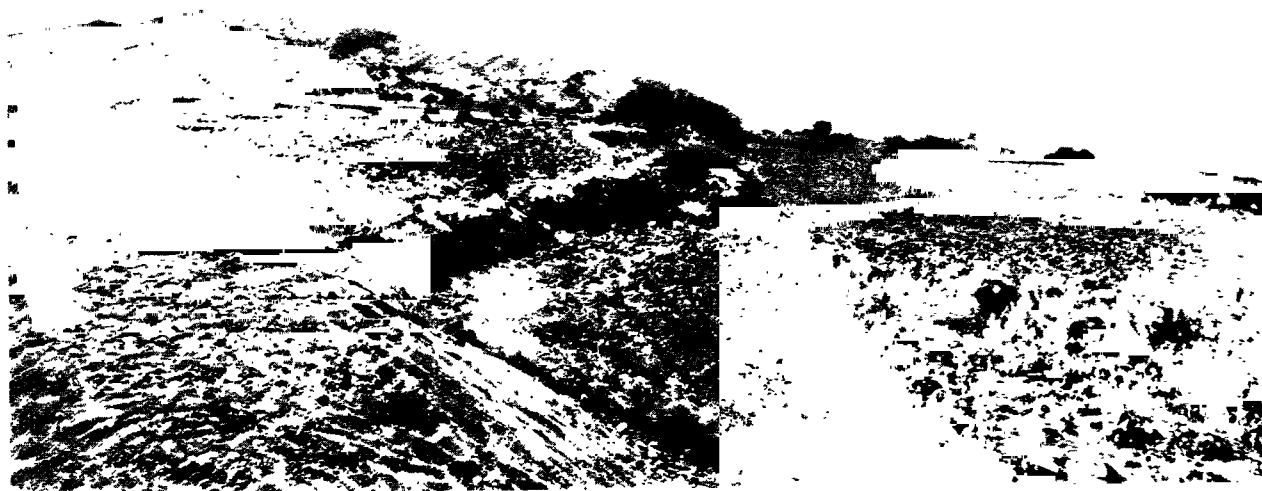

Fig. 187. Mersinaki. General view of the site. In the background, Vouni.

the fields indicating destroyed houses below the surface. At the western end of the shore a row of large, white, upright blocks of rubble exist, which possibly may be explained as the remains of an old quay or embankment. This can be followed for about 20 m. In any case the stones are not natural.

The ancient potsherds are concentrated in an area on the easternmost part of the plain, where the slope up to the bordering hills begin. From time to time some fragments of statues of stone or terracotta had been brought to light by the rains, but no remarkable finds were heard of. In order to determine how far the ancient culture layers extended towards the sea the excavation was started with a trench only a few metres from the shore and dug in the direction of the potsherd-area. Close to the sea, the field rises only about a metre above the sea-level and nothing but sand and pebble was found here. As soon as the culture earth was met with a little higher up the slope the excavation was continued in two parallel trenches at the same time. After further digging in these trenches, it seemed possible that statues in stone and terracotta were to be found in this direction. The trenches were therefore abandoned and the whole surrounding area arranged for an excavation on a larger scale: the area, having been defined by means of trial pits, was divided into squares of each 1.0 m. They were numbered from S. E. to N. W. 1—28, and from N. E. to S. W. A—U. The earth and sand from the excavation was transported on waggons on two lines of railway* down to the area just above the sea, where — as the trial trenches had shown — nothing but pebble and sand is to be found below the surface. All the elevations were counted from a fixed point at the sea-level.

* Thanks to the generous courtesy of Mr. J. L. Bruce of the Cyprus Mines Co., waggons and rails were placed at our disposal.

ARCHITECTURAL REMNANTS

The architectural remains uncovered by this excavation are very scanty. They can be referred to two separate buildings, or building systems. All that remains of one of them consists of fragments of tiny rubble walls. These are all based on the sand at about level 40.0 and seem to have belonged to a building with approximate right angles, oriented to the N. E. There are only three pieces preserved of this system of walls:

Wall 1. Width: 0.60 m. Height: 0.50 m.

This wall consists of rubble of medium size preserved to three courses.

Wall 2. Width: 0.60 m. Height: 1.0. m.

This runs in a N. S. direction and is founded on the sand. It was laid of irregular rubble of ordinary size, preserved to about five courses. The wall has been destroyed at both ends.

Wall 3. Width: 0.60 m. Height: 0.60 m.

It is of the same construction as the previous walls, and has been cut off at the eastern end, evidently at the same time as the pit in Square N, 18 etc. was dug. The western end of the wall, too, has been destroyed.

It seems impossible to draw any conclusions as to the shape or other characteristics of the building, of which these three walls are the only remains preserved. The fact, however, remains that the walls are founded on approximately the same level, they are of the same type, and oriented in accordance with a right-angled system. The bad state of preservation of the houses is fairly well explained by the great alterations of the site, which will be described below.

The walls ascribed to the other system of building were found in a much better state of preservation. They are grouped around a rectangular room which is oriented in different direction from the walls previously described. The walls are all founded on a higher level, in loose sand. The construction of the walls are the same for all but differ to that of the previous walls.

Wall 4. Width: 0.60 m. Height: 1.00 m.

This wall is founded on the sand at level 48.0.

It is built of rubble of various sizes and laid rather carefully in level courses, noted especially on the façade to the S., where five courses can be distinguished. The interior of the wall is filled with rubble without any distinctly separate courses. To the W., the wall had been destroyed. It is bonded with the next wall to which it forms a right angle.

Wall 5. Width: 0.60 m. Height: 1.75 m.

This is in general of the same construction as Wall 4. Near the middle of it, there is a doorway through the wall (Fig. 190) 1.10 m. wide. The posts on either side are constructed of carefully laid rubble. There is also a low threshold of rubble. The lower part of the doorway was filled with earth but the upper part was blocked with rubble blocks. The only possible explanation of this seems to be that the doorway originally was entirely open. When

MEHSINAWI
General plan

1:10000

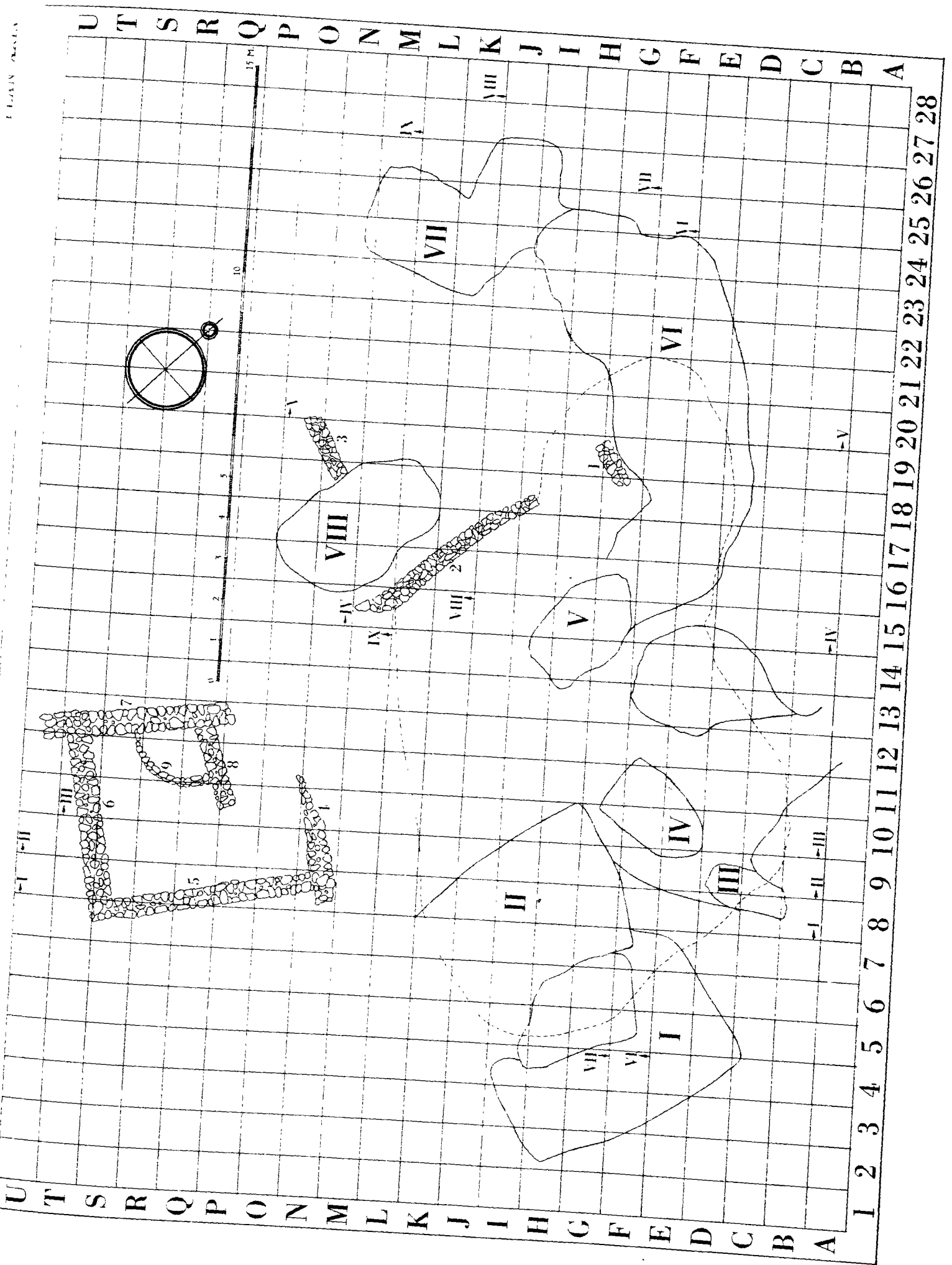
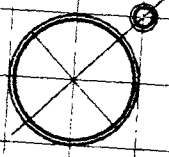



Fig. 188. The valley of Mersinaki seen from Vouni. The temple-site was situated on the shore to the left on the picture. In the bay, on the peninsula, the ancient city of Soli.

the house was abandoned and began to fall into ruins, the room in some way was filled with sand to about 1 m. over the floor. Later, when the walls fell in, and the rubble blocks were partly removed and washed away by the rain-water, some of them remained in the entrance resting on the layer of sand already silted into the room.

Wall 6 Width: 0.60 m. Height: 1.75 m.
is of the same construction as the previous walls; it is bonded with Walls 5 and 7.

Wall 7 Width: 0.65 m. Height: 1.60 m.
is also of the same construction. The western façade is comparatively rough and has not the carefully laid courses which are to be seen on the other side.

Wall 8 Width: 0.50 m. Height: 1.00 m.
is a short piece of wall which abuts against Wall 7. It diverges somewhat from the rectangular system of the rest of the walls. The wall ends after 2.10 m. with a straight edge.

In the angle between Walls 7 and 8 there is a line of rubble blocks forming a segment of a circle. This might have been a facing of a bench or a place for storing corn or something similar.



Fig. 189. Mersinaki. View of the excavation.



Fig. 190. Mersinaki. Remains of a house S. of the temenos.

The room enclosed by these walls had no other floor than the hard sand laid horizontally. Evidently, one entrance into the room was through either Walls 4 or 7, close to the north-western corner. This entrance could unfortunately not be determined as the corner had been entirely destroyed. As this house proved to be of little interest having no connexion with the rest of the excavation, it was thought that further investigations of other walls in this direction would mean too much expense. The possibility thus exists that there still may be some walls to be cleared S. of the house and belonging to it.

STRATIFICATION

Over the whole area excavated, two kinds of layers could be distinguished. The contrast between them is very clear. The circumstances, sometimes rather complicated, could be explained only by a careful separation of the main layers. Above a layer of pebbles at the same level as the ground water which was found at level 10.0, the filling consisted of fine, clean sand in almost horizontal courses which extended up to level 40.0 in the northern part of the area, and about 50.0 in the southern part. These layers of sand were, evidently, brought there by rains from the hill slope above, S. of the excavated area. Nowhere in these layers, potsherds, fragments of sculptures or similar objects were found. They constitute the virgin soil which existed on the site before it was used for sacred purposes. As a marked contrast to this horizontally laid, virgin filling, the top layers were distinguished, from level 40.0—50.0 to level 50.0—60.0. These, however, were of varying consistency on different parts of the area excavated and varied, too, as regards the depths. Over a great part of the area, a layer of slip-stones was found just above the virgin sand. Above these stones the filling consisted of brown, rather dark earth, on top of which the usual dark surface layer was found. The circumstances would be very clear, had not extensive alterations and disturbances caused a good deal of confusion in the originally distinct stratification. In the virgin layers of sand, large, irregular pits had been dug, some of them extending as far as to the



Fig. 191. Mersinaki. Section through layers above the temenos floor.



Fig. 192. Mersinaki. Section through layers above the temenos floor.

ground water level. The pits were of various shapes and sizes but they had all been dug from about the same level, 40.0. Most of them seem to be grouped without any intentional order. In the western part, however, one can perhaps define a certain arrangement: Pits V—VII together constitute a rough semicircle within which Walls 1—3, described above, are situated. Other pits are to be found E. of this, more or less closed line of pits. Nos. III and IV are deep and narrow, while Nos. I—II are wide and open, situated on either side of a pillar of sand which has been left (Plan XXIX).

It is naturally difficult as the edges of these pits are only occasionally vertical or straight, to draw the contours of the pits on a plan, and their shape is therefore better illustrated by sections. By such sections, too, the relation of the pits to the layers in which they are excavated is shown. The sections are arranged in accordance with a right-angled system so that there are five parallel sections (Nos. I—V) through the whole area excavated running from S. W. to N. E., and four parallel sections running from S. E. to N. W. (Nos. VI—IX). In this way all the pits are cut through by the sections as also the architectural remains. In the following descriptions of the sections, the layers are numbered from the surface to the bottom. The same fixed point is used for the elevations throughout the whole description.

Section I (Between Squares 7 and 8; Figs. 195, 209; Plan XXX, 1).

This section passes through Wall 5 and Pit II. The lower layers consist of the virgin sand, whose horizontal courses are clearly distinguished. These extend throughout the whole section. The termination downwards was never investigated in this section. Two distinctly different kinds of sand are observed: at the bottom (Layer 7) very fine-grained and hard packed sand, which sometimes grew almost like clay. Layer 7 was separated from the layer next above (Layer 6) by a strip of very coarse sand, or almost small gravel. This strip was found at different levels in Square F 8 at level 26.0, in Square K 8 at level 38.0. Above this strip, the sand in Layer 6 was coarse and not so hard packed as in Layer 7. Another strip containing ashes was noted at level 34.0—35.0 but extending only over Squares F

8—D 8. On Layer 6, the Wall 5 was founded. In the section it extends over Squares Q 8—S 8. Through the bottom layers Pit II is excavated down to level 16.0. In the section it extends over Squares F 8—K 8; its walls are vertical and the bottom somewhat rounded. The whole pit is covered by a large heap of rubble which has its greatest height between levels 34.0 and 44.0. These stones (Layer 3) belong to the same heap which is to be seen in several sections. The filling next below the stones in Pit II consisted of grey earth mixed with clay (Layer 4). It had a somewhat wet consistency. At the bottom of the pit, another heap of stones was found (Layer 5). These rubble blocks were of larger size. In Layers 3—5 fragments of statues were found. Layers 1—2 extended over most of the section. In Square C 8 they are interrupted by a terrace wall, 1 m. high, which prevents the earth in Layer 2 sliding down towards the sea in Squares A—B 8. Layer 2 consisted of dark brown earth, in general homogeneous. The surface layer, No. 1, is grey or black in colour.

Section II (Between Squares 8 and 9; Plan XXX, 2).

This section has many features common with Section I. The same stratification can be noted as regards the virgin sand-layers on the bottom (Layers 6—7). Pit II is here dug down to level 10.0 where a layer of pebbles is found (Layer 8). Layer 3, consisting of large rubble extends here not only over Pit II but further to the N. also in Squares F 9—D 9. Here Pit III is excavated in the sand layers as deep as to the pebble layer (No. 8) mentioned. Pit III is like a narrow hole in the sand and is obliquely cut towards the N. Towards the bottom, the filling (Layer 4) becomes darker and wet. The two surface layers above the heap of rubble are of the same consistency as in Section I. The terrace wall supporting them is found in Square C 9. The upper house in Squares N 9—S 9 is crossed by this section. The walls rest on the horizontally laid Layer 6, the upper part of which constitutes the floor of the room. Next above the floor a layer of brown earth (Layer 2 A) was found, about 0.35 m. thick, which differed from Layer 2 by its slightly darker colour.

Section III (Between Squares 9 and 10; Plan XXX, 3).

The section is laid through the house mentioned, and Pits II and IV. The section shows generally the same features as regards the house in the southern part of the area excavated. The horizontal courses of sand can be distinguished as in the previous sections. They rest on a bed of pebbles (Layer 10, which is seen at the bottom of both pits. The strip of pebbles which separates Layers 8 and 9 is recognized between the pits at level 26.0, and south of Pit II, in Square K 10 at level 37.0. North of Pit IV the strip is very thin, and terminates entirely between Squares C 10 and B 10 at level 26.0. Pit II appears in the section with rounded sides. It extends down to level 9.0 where it reaches the pebble-layer 10. From the bottom to level 22.0, the pit is filled with large rubble (Layer 5). The upper filling of the pit consists of the grey, sandy earth known from the previous sections (Layer 5). The same layer is found also in Pit IV where it contained some fragments of statues. Layer 4 is here followed by a layer of dark-red clay mingled with many fragments of statues. Pit IV is cut through the pebble-layer 10 down beyond the level of the ground water which was

Section I

VII VI



1

Section II

VII VI

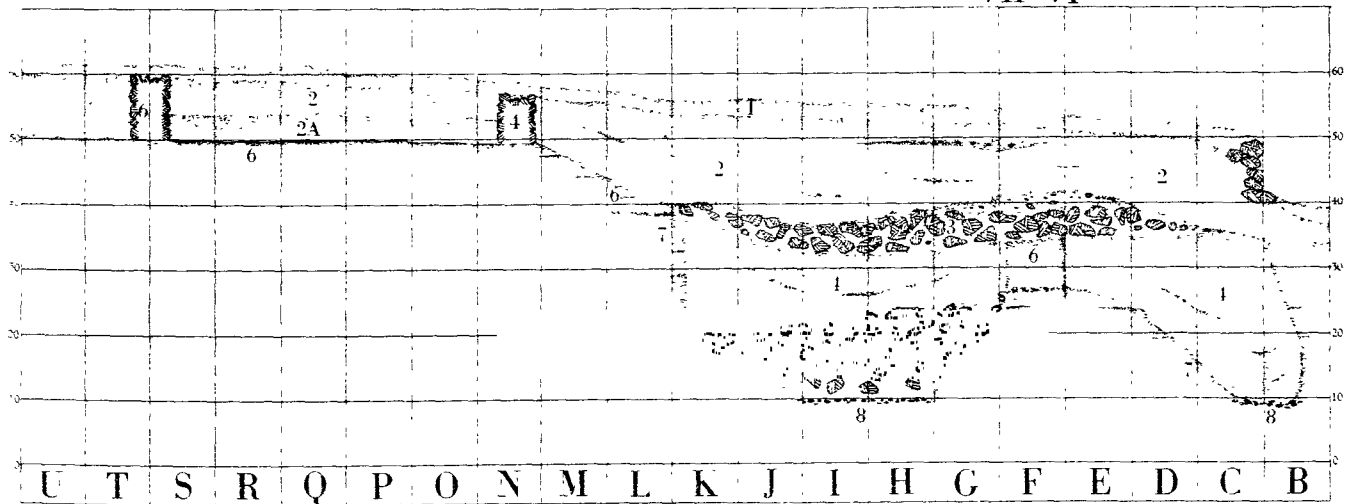

2

Section III

VII VI

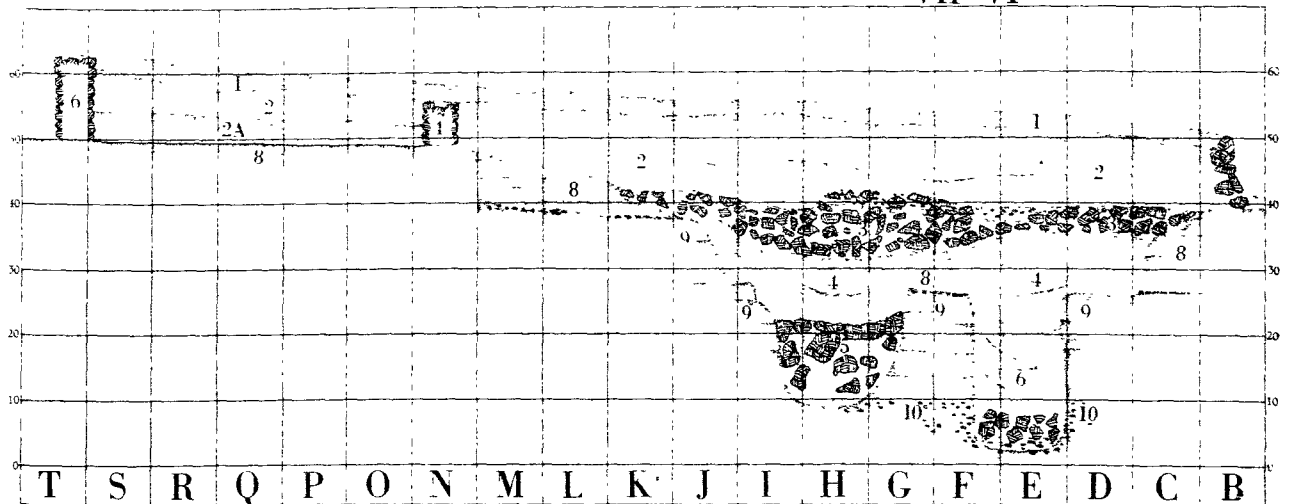

3



Fig. 193. Mersinaki. Layers resting on the rubble.



Fig. 194. Mersinaki. The filling in a pit distinguished from the virgin soil.

found at level 4.5. At the bottom, there were some large rubble blocks, but even below them the pieces of statues continued to the very bottom of the pit at level 2.5. Both pits were covered with the large heap of stones (Layer 3), noted also in the previous sections. At the upper part, this layer of rubble contained pebbles. The summit of the heap is found at level 42.0. The two top layers 1 and 2 are of the same consistency as in previous sections. The terrace wall comes here in Square B 10.

Section IV (Between Squares 14 and 15; Fig. 207; Plan XXXI, 1).

The section shows the layers in connexion with Pit V. In general the same features are noted as to the stratification in the previous sections. The horizontally laid sand is found at level 35.0–25.0 (Layer 5). The surface is somewhat disturbed in Squares D 15–F 15 where some minor diggings in the sand were noticeable. In the section Pit V extends over Square H 15 and partly Squares G 15 and I 15. The pit is rather shallow and the statues found *in situ* in the pit reached as far as through Layer 4 to the rubble of Layer 3. The statues also extended above the edges of the pit. Layer 4, which filled the pit covered the virgin sand to a thickness of about 0.60 m. The layer of rubble noted in the previous sections is found here, too. It rests on Layer 4 at level 32.0. At the lower part, Layer 3 contained pebbles. Evidently, water had passed between the rubble and followed the surface of Layer 4. Layers 1 and 2 are of the same consistency as in the previous sections. The surface layer is found above level 50.0.

Section V (Between Squares 19 and 20; Plan XXXI, 2).

This section is of special importance as it probably shows the remains of the floor on which the statues originally were placed. At the same time it cuts through Wall 3 and Pit VI and shows the relation between the floor-level mentioned and the architectural remains as well as one of the pits. The virgin sand layers extend here up to a level of about 35.0 in Square C 20, and 40.0 in Squares I 20–O 20. There seems to be no disturbance on the surface

of these sand layers except the Pit VI which has been dug through down to the pebble layer 7 at the bottom (level 10.0). This pit differs from the previous pits as there is no rubble on the bottom of it. The filling, on the contrary, is almost homogeneous, consisting of sandy dark-brown earth with single rubble blocks in. Just covering the pit a compact layer of rubble (Layer 4) was found. It was here, however, not so thick as has been noted in previous sections. Evidently, we are here in the borders of the large heap of stones which were found over most of the area excavated. In Square H 20, the rubble layer (4) rested directly on the sand. Towards the S., it was continued by another layer (3) which almost entirely consisted of fragments of statues in stone and terracotta. The layer appears in the section as a heap about 0.50 m. high, on the sand floor. It is especially worth attention that this layer 3 partly extends over the rubble layer (Layer 4) in Square H 20. Layers 1 and 2 are of the same consistency as in previous sections.

Section VI (Between Squares E and F; Fig. 196; Plan XXXI, 3).

The sections in E. W. direction show in general the same features as the previous ones. Pits I, IV, and VI are crossed by Section VI. Pit I is dug down to the pebble layer at the bottom (Layer 8) which is found — as all over the area — on level 10.0. It had perpendicular walls and was filled with a dark, sandy earth. Between Pit I and IV there is a portion of the virgin sand layers preserved up to level 34.0. Here the same layers are noted as in Section II: Layer 7 hard packed sand up to level 26.0 and Layer 6 rather coarse sand, separated from Layer 7 by a strip of pebbles. In Pit IV, two different layers are noted corresponding to those described in connexion with Section III. Between Pits IV and VI, only the lower layers of sand (Layer 7) are preserved. The upper layer (6) has apparently been removed. The eastern wall of Pit VI slopes gently down to the bottom on the pebble layer which was found at level 10.0. The pit was filled with sandy earth which darkened towards the bottom of the pit where also some fragments of terracotta statues were found. The layer of rubble blocks was found between level 32.0 and 44.0 extending as a strip almost the whole length of the section. It begins in Square F 6 and terminates in Square F 21. The rubble is partly mingled with pebbles, especially in the south-eastern part. The surface layers 1 and 2 extend over the whole section, and are of the same character as in previous sections.

Section VII (Plan XXXI, 4).

This section shows the same features as Section VI. Pits I, II, IV, and VI are crossed by the section. The upper surface of the virgin sand layers can easily be followed in the eastern part of the section on level 34.0; in the middle, on level 27.5. Layer 7 or the uppermost sand layer is thus missing on the latter part. Pit I is dug to the pebble layer on level 10.0. It was filled with a sandy, rather dark earth which did not contain any potsherds or pieces of statues, as did all the other pits. The section cuts through a very small part of Pit II but here the same layers are met with as in Sections I—III: at the bottom large rubble blocks (Layer 5); above them a layer of grey earth (Layer 4) which continued up to the

Section IV

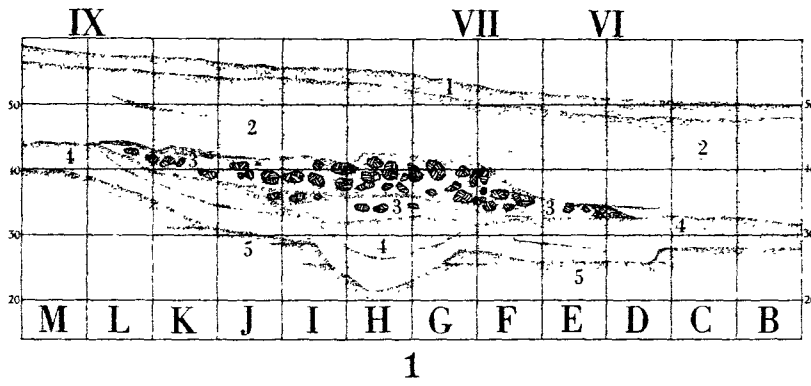

1

Section V

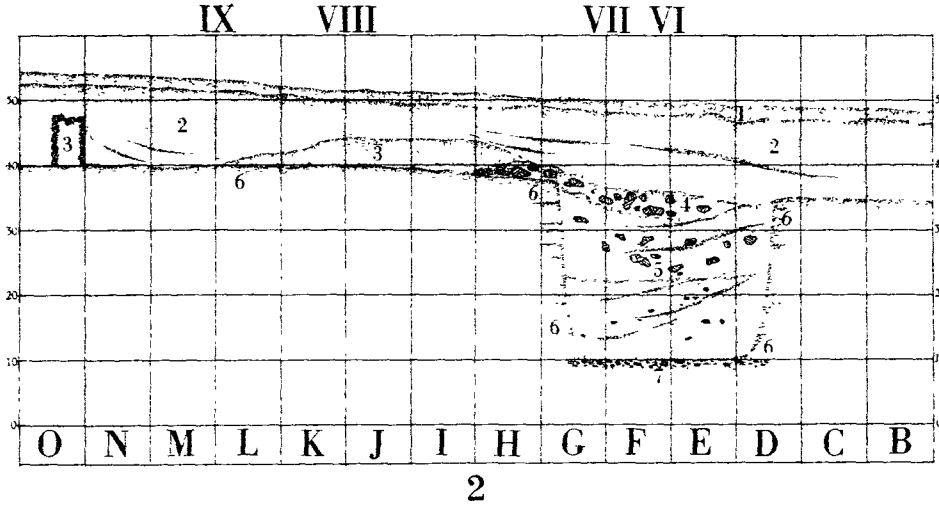

2

Section VI

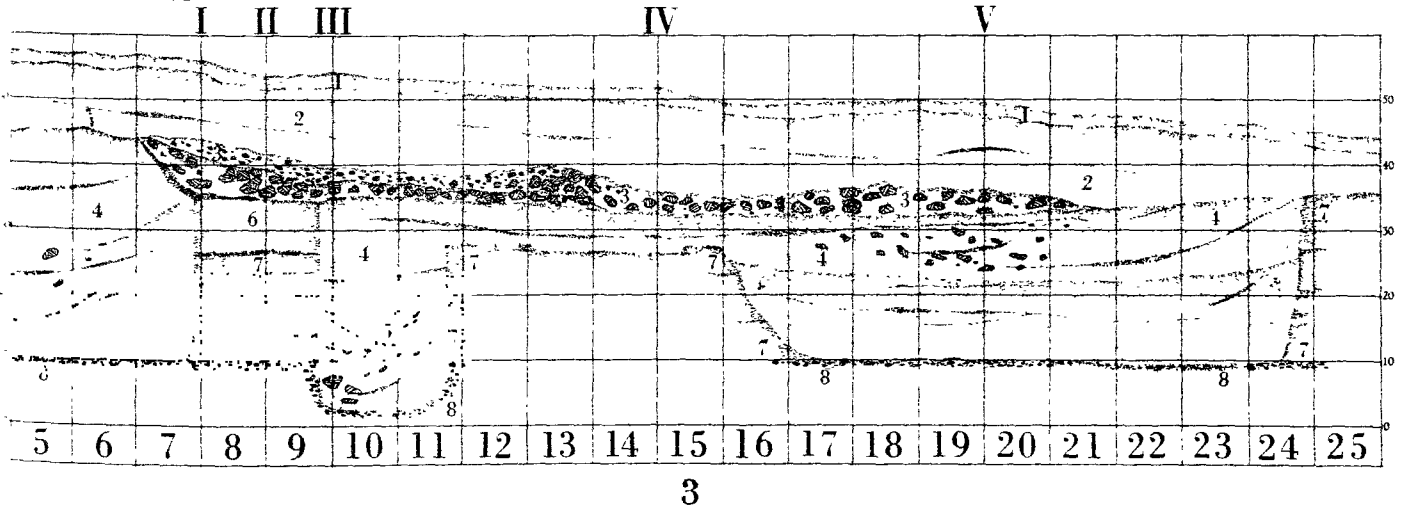

3

Section VII

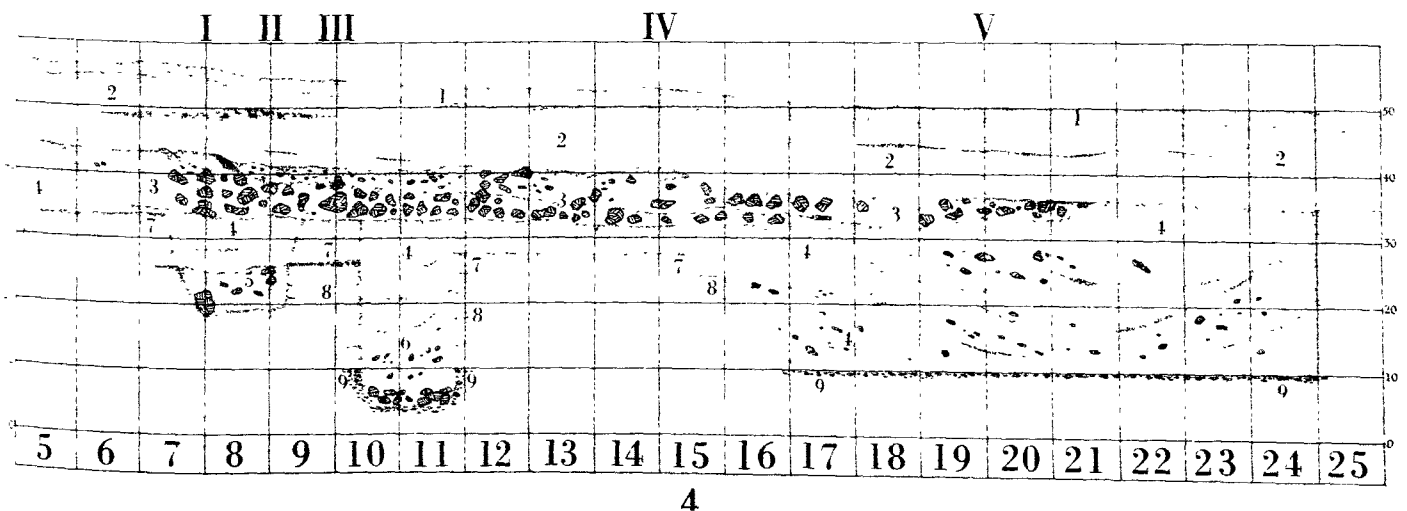

4



Fig. 195. Mersinaki. View of the excavation.



Fig. 196. Mersinaki. View of the excavation.

edge of the pit (level 44.0). Layer 4 is also recognized in Pit IV but here it does not extend to the bottom. At level 21.0, it is followed by Layer 6 which consists of dark clay with a great many pieces of terracotta statues. The bottom of Pit IV is found on level 4.0, where some rubble blocks marked the termination in the pebble layer (9). In Pit VI the same stratification as in Section VI is noted. The large rubble layer (3) has almost the same extent as in Section VI. The surface layers 1 and 2 are undisturbed as in previous sections.

Section VIII (Between Squares J and K; Plan XXXII, 1).

This section crosses only one pit (No. VII), but it shows the relation between this pit and the floor-level at 40.0. The virgin sand layers extended up to this level, on which Layer 3 rested. This consisted of a compact heap of pieces of statues in stone and terracotta. The layer is terminated against Wall 2 which is crossed by the section in Square K 17. The wall had been demolished to about the same height as the heap of terracotta fragments, or to level 44.0. Pit VII was filled with a sandy earth similar to that of Pit VI (Layer 4 in Sections VI and VII). Above are the usual two surface layers.

Section IX (Between Squares L and M; Fig. 197; Plan XXXII, 2).

This section shows practically the same features as Section VIII, only with the difference that Pit VIII, too, is crossed. This does not extend down to the bottom layer of pebbles on level 10.0. It has been dug to a depth of 23.0 only.

As is seen by the description of these sections the upper surface of the virgin sand layers is found at practically the same level throughout the whole area excavated. The pits excavated in the sand layers have naturally caused some disturbances also as to the upper level.



Fig. 197. Mersinaki. The filling of Pit VII (left) distinguished from the surrounding virgin soil (right). In the fore-ground, the bottom layer of pebbles.

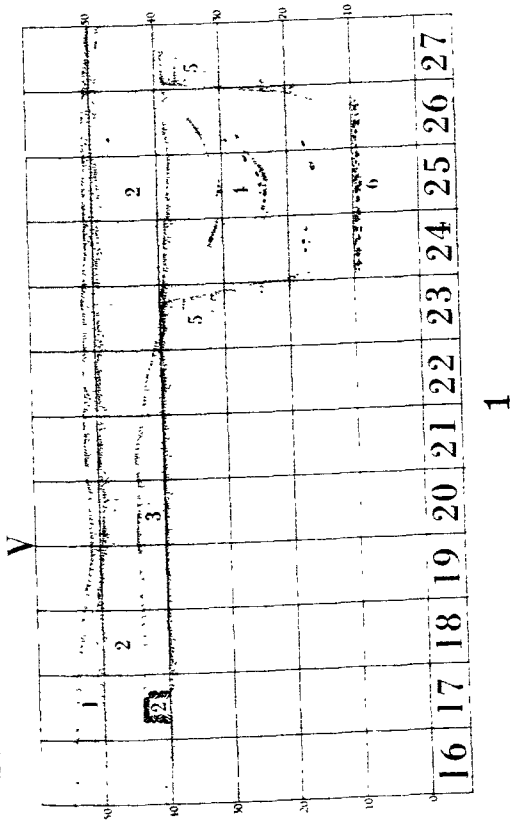

Fig. 198. Mersinaki. Detail of filling in Square H 14

The original surface, however, is preserved in Squares J—K 18—21, where it was found at level 40.0. As a rule, the pits were filled with a sandy, dark layer of earth, which also contained fragments of statues and pottery. Such fragments were never found in the sand layers. Two pits (Nos. V and VIII) were excavated only to a minor depth while most of them were dug down to the bottom layer of pebbles found at level 10.0 (Pits I—III, VI, VII), and one pit (No. IV) had been excavated partly through the pebble layer as deep as to level 4.0. Two of the pits (Nos. II and IV) had a bottom stratum of large rubble. Next above the filling of the pits another layer of rubble was found, the extent of which was well limited in the trenches. It is irregular, oval in shape, and has its greatest extent in S. E. — N. W. direction, between Squares I 5 and F 22 with the greatest width between Squares B 10 and L 13. This layer of rubble, too, contained statues and pieces of statues. Pieces of statues were also found in a layer which partly covered the rubble layer, but which partly rested directly on the virgin sand. This was observed in Section V. The sequence of the layers in Square I 19—20 show the close connexion between the two layers. The rubble blocks must have arrived at their place contemporary with, or earlier than the layer of terracotta fragments. The question whence these rubble blocks originate arises. The most likely explanation seems to be that they are loose stones from destroyed walls and, in such case, they should be referred to the building of which only Walls 1—3 are preserved. The rubble rests on the same level as these walls (40.0), which thus is supposed to have been the original floor-level of the building in question. On examining the sections it will be clear that the original floor of the building is preserved only in a comparatively small area between Pits VI, VII, VIII, and the northern part of Wall 2. This is also the area where most of

MERSINAKI

Section VIII



Findings *in situ*, Pit IV.

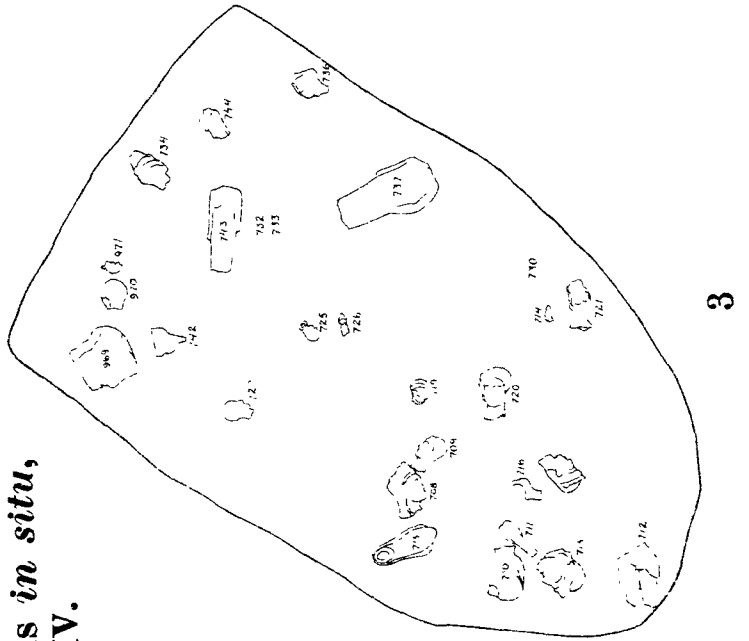

Section IX

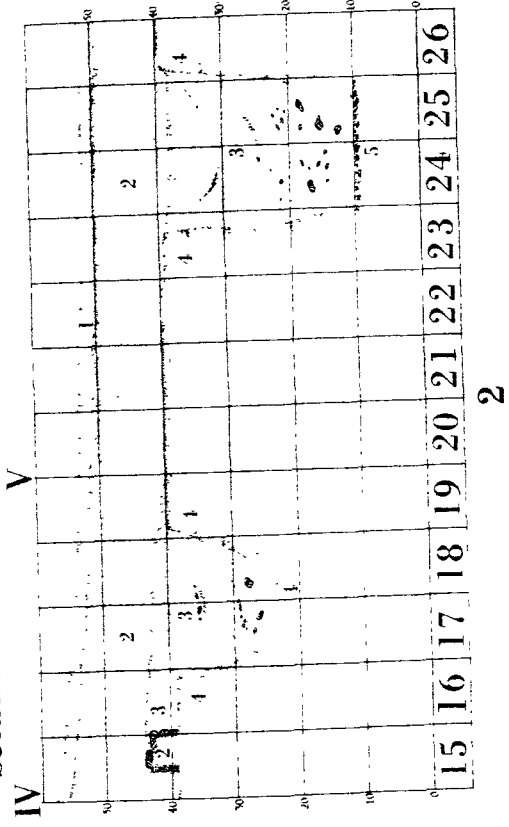

Findings *in situ*, Pit V.

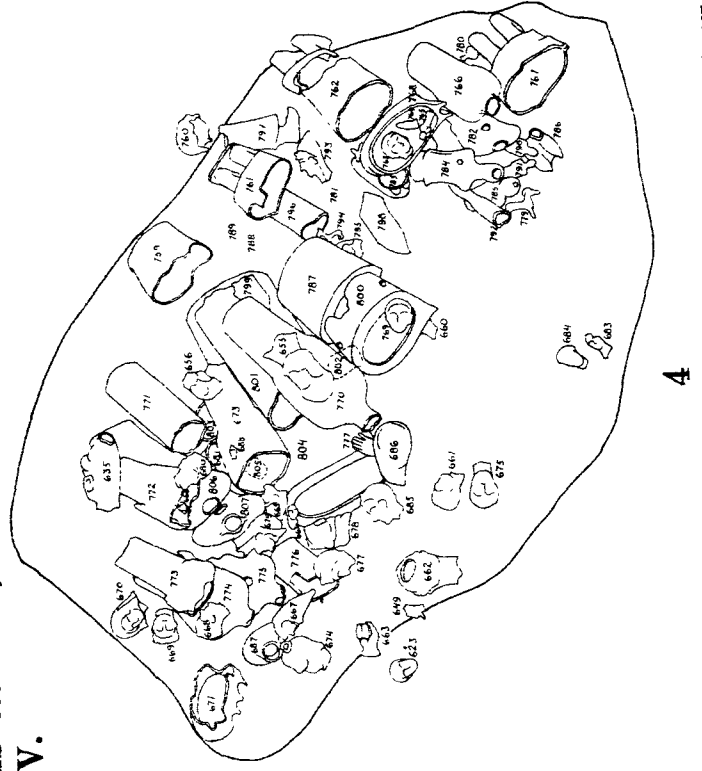

the sculptures were found. Evidently, the statues had some connexion with the building. Possibly the walls were only enclosures for a temenos around it; the pits were dug, starting from the ground of that time. As has already been pointed out Pits V—VIII are grouped as a circle around the architectural remains and the heap of sculpture fragments. Most likely the pits were dug in the borders of the temenos. The contents of the pits vary very much. While Pit V was quite filled with statues and pieces of terracotta, others contained only a few fragments. We will later on return to the distribution of the finds within the excavated area. It must here be kept in mind that the rubble layer contained fragments of statues as did the layers in the pits and close to the virgin sand layers. Nothing interesting was found in the two surface layers which were apparently brought down to their present position by rains after destruction of the temenos. Before going more in detail as to the distribution of the finds, the description and classification of them will be made.

FINDS

OBJECT REGISTER

601. Bronze coin. *Obverse*: head of Arsinoe III; face missing, within dotted circle. *Reverse*: double cornucopia with various fruits; around, inscription *ΠΤΟΛΕΜΑΙΟΥ* (much worn); *ΒΑΣΙΛΕΩΣ*; the whole in dotted circle. Diam. 1.3. Weight 2.3.
602. Diobol of bronze. *Obverse*: head of Aphrodite looking l. *Reverse*: *ankh* within wreath. Diam. 1.6. Weight 3.3.
603. Bronze coin. *Obverse*: head of Alexander the Great r., with helmet; back of head damaged. *Reverse*: eagle standing on thunderbolt, l.; open wings; inscription illegible. Diam. 1.7. Weight 2.9.
604. Female head of grey terracotta, broken off at neck; back of head missing; part of left side restored. Face made in a mould; archaic type similar to No. 793. Height 15.0. G 9.
605. Male head of soft, white limestone, broken off at neck. Oval face with full cheeks; small mouth; vertical, straight nose; carelessly worked eyes without lids. The front-hair is conventionally curled in two arched lines above the forehead. The head wears a conical cap and a wreath composed of myrtle-leaves and hanging fruits. Flat, unsculptured back. Height 10.4. Temples 4.1. Forehead to back 4.7.
606. Terracotta lamp; biconical body; moulded upper side with incised lines radiating from a large central hole. Long nozzle with horizontal upper side. No handle. Traces of red slip. Length 8.3.
607. Various fragments of terracotta heads. Found in Trench I. G 8—9.
608. Male statue of hard, grey limestone. Head missing. The figure stands on a square, thick base resting on left leg with right leg slightly bent; upright, fat body; right arm slightly bent along the side, the hand holding a bird; left forearm raised to the breast, the hand holding the end of the himation falling from the shoulder. Bare feet, breast, and arms; a deeply folded himation reaching almost to the ankle is wound around the body, the end hanging over left shoulder. Right arm and legs are not sculptured free from the body and background, and the remaining sides are comparatively thick. Flat, unsculptured back. Height 51.5. G 8.
609. Male statue of hard limestone, feet and head missing. The figure rests on left leg, with right leg slightly bent. The body is upright and very fat with a prominent abdomen. Right arm folded across the breast inside the himation; left arm slightly bent along the side, the hand holding the vertically hanging folds of the himation. The statue wears a long himation wound around the body. The folds are very roughly sculptured. The back is rounded but unsculptured. Height 34.5. Abdomen to back 11.4. G 8.
610. Male statue of hard limestone; feet, head, and right arm missing. Upper part worn. The statue rests on left leg, with right leg slightly bent backwards; rather thick, upright body. Right arm sculptured free from body; left arm bent close to the side, the hand holding a fold of the himation hanging from left shoulder. The statue wears a short-sleeved chiton and a himation wound around the body, the end of the himation hanging from left shoulder over breast and abdomen. The himation leaves the lower parts of the legs uncovered. The legs are not sculptured free, but in a relief against the unsculptured back; this arrangement is evidently for strength. Height 38.5. Shoulders 15.5. Abdomen to back 10.4. F 8.
611. Large, bearded head of greenish-grey terracotta, broken

- off below neck. Oval face with a long, pointed beard, no moustaches; very small, smiling mouth with deep corners; long cheeks and nose; large eyes without modelled lids; arched eyebrows; front-hair conventionalized with small, spiral curls most of which are broken; large, plain ears. Thick ribbon in hair. Height 32.0. Temples 13.8. F 9.
612. Statue of hard, grey limestone; lower part of legs with feet, and head missing; summary work. The statue is resting on the left leg, with right leg slightly bent backwards. Upright body with convex abdomen; left arm akimbo; right arm folded over the breast inside the himation. Long, vertically folded chiton. Around body and arms an obliquely folded himation is wound. Unsculptured, rounded back. Height 34.5. Shoulders 15.0. Abdomen to back 12.0. F 8.
613. Small, male terracotta head; broken off at neck; made in a mould; carefully sculptured face; long hair at the sides; circular, flat hat. Height 3.0. F 9.
614. Male head of soft, white limestone, broken off at neck. The face is carefully sculptured, triangular in shape. The faint, archaic smile has almost disappeared; nose is vertical; eyes with lids in shape of myrtle-leaves; large, carelessly worked ears. Curly front-hair and short hair on the nape of the neck, marked by incised, crossed lines. The head wears a conical head-dress and around this a myrtle wreath. The flattened back is vertical. Height 14.2. Temples 6.4. Forehead to back 6.1. F 9.
615. Female head of red terracotta, broken off below neck; part of hat missing. The head belongs to a statuette which was probably made in a mould. Oval face with smiling mouth; eyes without lids; front-hair artistically arranged in small, vertical curls. Fixed to top of head is a circular hat. Height 6.8. F 9.
- 616 - 1039
Male statue of hard, grey limestone. Feet missing. Surface much corroded. The statue rests on left leg, with right leg slightly bent. Left arm akimbo, at the back; right arm folded across the breast inside the himation. The male wears a folded chiton and a himation wound around body and legs, outside the arms. The head (No. 616) is broken off obliquely below neck; face slightly turned to the right. The face is somewhat triangular, with strong, projecting chin, carefully worked mouth, straight front- and nose-line; broad forehead with slightly prominent centre. Eyes are realistically sculptured and deep, looking upwards, short, curly hair. Face is worn, especially over forehead and nose. Total height 180.0. Height of head 31.0. Forehead to back 22.3. Temples 15.2. F 9. 36.0.
617. Head of female statuette in dark-red terracotta. The statuette was probably made entirely in a mould. The head is broken off below the neck, strictly frontal position, classical face with aquiline mouth; slightly concave nose, realistic eyes, long hair parted in the middle. Height 14.0. F 8.
618. Male statue of hard, yellow or grey limestone. Hasty work. Small, irregular base. Straight left leg; right leg slightly bent backwards; upright body; both arms folded holding a large fruit to the breast. Chiton visible below the neck. Himation with roughly sculptured folds, wound around body and arms, and reaching just above the feet. Rounded, unsculptured back. Height 39.5. Shoulders 16.5. Abdomen to back 11.5. F 9.
619. Head of a child of hard, coarse-grained limestone, broken off below chin. Very much corroded. The face is almost round and seems to have been carefully worked, though no details now can be distinguished. Height 13.5. F 9.
620. Statue of a child holding a bird; hard, grey limestone. Lower part from knees, and head, missing. Upright body. The bird, a dove (?), is held by the wings of the child to the child's breast. Long, vertically folded tunic and bracelets round the wrists. Height 30.1. E 8.
621. Circular, disc-shaped bronze mounting, with somewhat projecting centre. Diam. 4.0. G 9.
622. Female head of coarse, dark-red terracotta, broken off below neck. Thick neck; fat, oval face with heavy chin and cheeks; straight nose; large eyes with high forehead. Hair covered by a veil having the ends visible. The head seems to be made without mould. Height 10.4. Total width 6.3. Temples 4.5. B 9.
623. Female head of dark-brown terracotta. Back missing. Left part of nose damaged. Oval face made in a mould, rather rough details; straight, prominent nose; deep eyes with lids. Hair covered by a veil. Height 12.3. H 14. 35.0.
624. Male head of gaitty, hard limestone full of small holes. Head broken off at neck. The face is oval and shows a rather soft workmanship. Straight mouth with small angles at the corners; straight nose, and arched upper eyelids; carelessly worked ears, and roughly designed short hair. Traces of red paint on eyes and hair. Surface slightly worn. Height 10.1. Forehead to back 8.8. Temples 6.5. F 14. 33.0.
625. Bird of terracotta; fragment of a large statue. Bird resembles a dove. Length 12.9. F 14. 33.5.
626. Fragment of a head, probably female, of dark-red terracotta; back part missing. Oval face made in mould and worked over. Height 8.7. F 14. 33.5.
627. Triangular bronze arrow-head with socket, triangular section at the point. Length 4.3. F 14. 33.2.
628. Head of a terracotta horse of the same type as No. 1040. Fragmentary. Length 9.0. F 14. 35.0.
629. Head of a terracotta horse, made in a mould. Curved neck and small, carefully worked head. Length 5.1. F 14. 33.8.
630. Female head of dark red terracotta, broken off below chin, part of surface damaged; back of head missing. Classical type with oval face; small, pointed chin; aquiline mouth; straight nose with thin nostrils; front-hair conventionalized by means of small, impressed dots; on back of the head a veil leaving just the ears uncovered. Height 12.3. F 14. 34.0.

631. Female head of pale terracotta. Broken below chin; back of head missing. Face made in a mould; oval shape; pointed chin; aquiline mouth; straight nose; elliptical eyes with lids and carelessly marked iris; hair parted in the middle. Height 16.5. F 13—14. 34.4.
632. Bearded head of dark red terracotta. Right side of face preserved. Other side restored. The expression is powerful with a sensitive mouth, surrounded by a large full beard and moustaches. The beard is made in a peculiar technique by adding small lumps of clay side by side; the moustaches by incised dots and lines in the fresh clay. Puffy cheeks, and straight nose, realistically sculptured. Front-hair is conventionalized in the same technique as the beard. Height 21.0. F 13. 37.5.
633. Male head of soft, white limestone; broken off at neck. Left side of the face with the chin is badly damaged. The face was oval with rather full cheeks. Eyes with lids in shape of myrtle-leaves. Conventionalized front-hair. The hair on the back of the head is half long, and marked with incisions arranged in an irregular pattern of lozenges. Over the crown, the hair radiates from one point. Height 17.5. Temples 9.7. Forehead to back 10.3. F 14. 32.0.
634. Male head of dark-brown terracotta, broken off below chin; upper part of the skull missing. Oval face with meagre cheeks; straight mouth with thin lips; projecting nose; eyes only faintly modelled, the lids and irises being indicated by means of black paint. Front-hair arranged in small spiral curls. Around the crown is a wreath composed of ivy-leaves. The head wears a cap, the edge of which is visible on the nape of the neck. Height 17.5. G 14. 32.0.
635. Female head of coarse, red, well baked terracotta. Broken below neck; top of head-dress missing. Oval face with prominent chin; small, slightly projecting mouth with archaic smile; straight, slanting nose and forehead; long, elliptical eyes with lids and arched brows; large, bowl-shaped, projecting ears. The hair is held up in a roll above the forehead, and its curls are marked by three rows of button-shaped knobs. Above the hair-roll is a diadem and a high conical head-dress. The head is hand-made and built up of layers of clay. The face moulded, but entirely worked over. Height 29.5. Total width 14.0. Temples 8.4. I 14. 28.5.
636. Bird (dove?) of terracotta; part of a votive statue. Length 11.8. E 14. 28.5.
637. Male head of hard, white limestone broken through neck. Face is round with full chin and cheeks. Mouth is thin and smiling in exaggerated way with marked lines from the nose to the corners of the mouth; small dimple just below the nose. Straight, short, and broad nose with drilled nostrils. Small eyes with finely marked, curved lids; gently curved forehead and temples. Short, curly hair roughly designed with small front-curls. The head has a ribbon tied below the occiput. Large, prominent, roughly sculptured ears. Tip of nose damaged. Height 11.0. Temples 6.9. Forehead to back 9.0. E 14. 29.0.
638. Female terracotta statuette; made in a mould; head missing. Square base, upright body; left foot somewhat advanced; right arm along side; left arm bent over the breast. Long, folded himation over left shoulder. Mould seems to have been rather worn. Interior hollow. Round, unsculptured back. Height 16.5. E 13. 32.0.
639. Lower part of a terracotta statuette made in the same mould, as No. 1095. Height 6.8. F 13. 32.0.
640. Female head of grey terracotta; broken off below neck; upper part with right temple, damaged. Triangular face made in a mould; thin, pointed chin; archaic smile, straight, prominent nose; eyes in shape of myrtle-leaves with modelled lids. Conventionalized front-hair; wreath with upright leaves. Plaits on either side of neck. Height 16.8. F 14. 32.0.
641. Upper part of a male statue of soft, white limestone broken off below the breast. Both arms were close to the sides; left hand evidently holding a branch, the top of which is visible on the upper arm. The head is looking straight forwards and seems to be too small. Face is triangular in shape and has a faintly smiling mouth, vertical nose; flat eyes, without lids, in shape of myrtle-leaves. Curly front-hair; short, conventionalized hair on the nape of the neck; radiating grooves over the crown. Round the hair, a wreath composed of ivy- and laurel-leaves. The statue wears a vertically folded chiton with short sleeves, and an obliquely folded himation on the left shoulder. Flat back. Height 9.5. Shoulders 13.7. Breast to back 4.7. E 13. 31.5.
642. Archer of terracotta; part of a chariot-group. Lower part of body was never finished. Carelessly sculptured face; conical cap with upturned head-dress. Height 14.0. E 13. 30.0.
643. Terracotta horse in "snow-man" technique; right foreleg and left hind leg missing. Part of a chariot-group. Thick, tall neck; narrow, curved nose. Height 9.2. E 13. 28.5.
644. Terracotta horse; part of a chariot-group; legs partly missing. On the high neck, part of a yoke. Height 12.0. E 13. 31.0.
645. Male head of red, gritty terracotta, broken off at neck. Some leaves of the wreath missing. The face is rounded with a prominent chin, smiling mouth; straight nose and forehead; elliptical eyes with lids and low, curved brows; fairly realistic ears. The hair is short and curled around the forehead. Around the crown, is a laurel wreath. Traces of black paint on the front-hair. The whole head seems to be hand-made and there are no traces of a mould on the face. Height 11.9. Total width 9.9. Temples 6.7. F 13. 32.0.
646. Piece of a terracotta chariot with the driver broken away from a group with horses. Right half of the chariot preserved with a piece of the beam. The driver is bearded and has a conical helmet. Height 13.5. F 13. 30.0.

647. Male head of dark-brown terracotta; broken off below chin; back of head missing. Small chin and mouth; somewhat prominent, clumsy nose; eyes carefully modelled with realistic lids; iris not marked; high, straight forehead. Short hair visible at the temples; ears carefully sculptured. The head wears a cap with up-turned edge. Height 14.0. F 13. 30.5.
648. Terracotta lamp on flat, slightly raised base, biconical body with central hole encircled by an incised line; long, almost horizontal nozzle; small side-knob. Red slip. Length 8.9. F 13. 30.2.
649. Bearded head of dark-red terracotta; broken off at neck; archaic type with long, pointed beard; no moustaches; smiling mouth; upturned nose (tip missing); prominent eyes with lids; conical head-dress. Height 7.5. H 14. 31.5.
650. Male head of soft, white limestone, broken off at the chin. Much worn. Eyes without lids. Vertical brow- and nose-line. Conventionalized front-hair; short hair on the back of the head. Wreath composed of laurel-leaves and fruits in the hair. Height 10.5. F 14—15. 30.0.
651. Terracotta horse; part of chariot-group; nose, ears, and part of legs, missing; long, upright neck. Height 10.2. F 13. 32.0.
652. Small, female terracotta statuette used as a jumping-jack. Arms and legs missing. They were made separately and fixed on the body by means of strings. For that purpose the body is pierced for fixing the arms. The legs were fixed by a strong thorn through three pierced projections on the lower part of body. The statuette wears a chiton girdled below the waist. On the head, there is a crown with a hole in the centre. Flat back. Mould-made. Height 7.9. F 13. 28.8.
653. Bearded terracotta statuette, forming part of a chariot-group. Only the upper part from waist was sculptured; arms and beard partly missing. Archaic face with somewhat smiling mouth; conventionalized front-hair; conical helmet with buttons at the ears. Height 13.3. F 15. 29.7.
654. Male head of dark-red terracotta, broken off at neck; back missing, nose partly damaged. Oval face with powerful chin; well marked mouth with arched upper lip. Straight, prominent nose; eyes with lids in shape of myrtle-leaves. Hair is parted in the middle; wreath, partly preserved, in hair. Height 12.2. G 15. 32.0.
655. Bearded head of brown terracotta; back missing; broken off below neck; pieces of the face restored, especially on right side. Comparatively short beard, marked with carelessly incised lines; long moustaches. The nose is slightly upturned; with gently sculptured nostrils, realistic eyes with iris and pupil marked by an incised circle and central dot. Curved forehead and faintly sketched hair. The face seems to have been done in a mould, but is carefully worked over. Height 32.5. H 15 29.5.
656. Bearded head of dark-red terracotta. Only left side of face preserved. Oval face with thin beard and moustaches indicated by means of impressions of a scribe; straight nose, slightly diverging from the middle axis of the face; large eyes with curved eyeballs and sharply marked lids. The face seems not to have been made in a mould. Right part of the face and upper part of the forehead restored in gypsum. Actual height 19.4. H 15 24.5.
657. Terracotta horse belonging to a chariot-group. Not damaged. The horse seems to be the right outer one of the four. Very rude technique. Height 13.5. H 13—14. 28.5.
658. Male statue of hard, grey limestone. Mediocre work. Small irregular base with sloping upper side; right leg slightly bent; stiff, upright body; right arm along the side, the hand holding a flower; left forearm raised, the hand holding the end of the himation which hangs down from the left shoulder. The head found separate from the body is very roughly sculptured; round face, full cheeks and sloping, prominent chin; nose broken; eyes carelessly worked; short hair. The figure wears a short chiton and a folded himation, wound across the abdomen and hanging over the left shoulder. The himation reaches to below the knees. The legs are not sculptured free from the background. Unsculptured back. Height 48.5. E 9.
659. Relief-plaque of white, coarse-grained marble. Left bottom corner broken off and mended. Left and right top-corners with a considerable piece of upper right side missing. Figure chipped at the break and in front of the head-dress; left hand missing; surface worn on the face, at the girdle, and near right leg. On the flat plaque, Athena is sculptured in low relief with weak, but distinct details. The figure is standing frontally with the head slightly bent and in right profile. She rests on the left leg, with the right leg slightly bent. Right arm is a little bent and kept away from the body; the hand holds a spear which rests on the ground. Left arm is also slightly bent so that the forearm has a horizontal position to the elbow resting against the hip. Left hand holds some object, possibly a helmet which now is missing, and at which Athena was looking. The face is carefully worked with nose and forehead aligned. She wears a cap or a short veil wound round the head; the hair falls in short plaits at the back of the neck. The veil leaves some curly front-hair free. The figure wears a chiton, loosely girdled at the waist and falling over the girdle on both sides. Right leg up to the hip is clearly visible below the folds of the chiton, but on the left side the heavy, vertical folds entirely hide the leg. The arms are bare. A thin peplos or veil is attached at the back of the shoulders, and falls down in two skirts merely defined on the background. Height 24.4. Width at base 18.25. Thickness 2.8. Total height of figure 21.9. Shoulders 5.4. Pelvis 5.0. H 8. 25.0.
660. Damaged head of soft, white limestone broken off at the chin. Surface very much worn. Oval face with vertical nose and eyes without lids. Conventionalized front-

- hair with a roughly indicated wreath. Height 8.2. Temples 4.1. Forehead to back 3.9. G 15. 26 5.
661. Male head of hard, white limestone broken off below neck. The face is oval and softly worked. Eyes are sculptured; large eyeballs, and carefully designed lids, the upper one arched. The upper side of the crown and the occiput are flattened, which imparts to the head an angular profile. Short, curly hair with parts extending over the temples, apart from the front-hair. Surface is rather worn, especially over the lower part of the face. Tip of nose broken. Height 15.0. Temples 7.5. Forehead to back 10 6. G 14. 27.0.
662. Bearded head of yellow, coarse terracotta, put together from many pieces. Broken off with part of the breast and a vertically folded tunic; left side of forehead damaged. Oval face with short, full beard and moustaches naturalistically marked with short, incised lines; straight nose. Realistic eyes with modelled lids, and irises indicated by means of incisions. On the nape of the neck, short hair. The head wore a wreath, which is wanting now; both ears missing. Large, circular hole on the crown. Height 31.5. Temples 13.5. G 14. 27.0.
663. Left hand holding a small box from below. Soft, white limestone. The hand never belonged to a statue but was made as a votive offering fixed on a wall. The hand is carefully sculptured with slightly bent fingers. The box has concave sides. At the wrist, the piece is straight cut and provided with incised lozenges. In the middle, there is a circular hole for the fixing peg. Length 13.0. H 14. 30.5.
664. Female head of dark-red terracotta; back; of head missing. Oval face made in a mould (surface partly missing); small mouth; straight, prominent nose; eyes with roughly sculptured lids. Hair seems to have been parted in the middle and covered by a veil. Height 12.0. H 14. 31.0.
- 665-687.
Upper part of male statuette of brown terracotta. Right side and part of breast filled with gypsum. Upright body; left arm bent; fingers missing; straight, thick neck. Long, oval face with smiling mouth; thick nose; faintly modelled eyes; short hair curled up on forehead and nape of neck. Low, conical head-dress with upturned edge; plain chiton and himation over left shoulder, the edge of which is formed as a zigzag band. Height 38.0. H 14. 31.0.
666. Terracotta head in "snow-man" technique. Plaits on either side; conical helmet. Height 5.4. H 14. 30.5.
- 667-774.
Female statuette of buff terracotta. Hollow, wheel-made body, somewhat depressed from in front; wide shoulders; arms along sides; female breasts faintly marked. Small head on a thick neck; face made in a mould; archaic expression; curly front-hair; high, conical head-dress. Plaits (missing) hanging down on either side of neck. Venthole for evaporation in back of body. Height 74.0. H 14. 28.5.
668. Male head of reddish, well-baked, gritty terracotta. Broken off at neck; both ears chipped and parts of the wreath missing. Oval face with firm, rounded chin; small mouth with curved lips; thin, straight nose; rather deep eyes with lids and low, realistic brows; slightly curved, high forehead and naturalistic ears. Short, curly hair round the forehead and laurel wreath round the head. Entirely hand-made; face modelled. Height 15.0. Width 10 4. H 14. 30.5.
- 669-1043
Male statue of hard, grey limestone. Left hand and piece on the back of right shoulder missing. The head (No. 669) was found apart from the body (No. 1043). The statue stands on a small, rectangular base, resting on left leg, with right leg slightly bent backwards; upright body; head looking forwards. Right arm slightly bent along the side, the hand holding a rounded object. Left arm bent along the side, the forearm holding the end of the himation. The neck is very short and thick; face rounded with full cheeks; straight nose; eyelids marked; the front-hair is summarily worked; wreath of myrtle-leaves in the hair. The statue wears a short-sleeved, folded chiton and a himation hanging over left shoulder, with a mass of folds hanging over left arm. The technique is rough. Rounded, but unsculptured back. Height 67.0. H 14. 30.8.
670. Female head of coarse, red terracotta, covered by a thin red slip. Broken off at neck. The head is framed by a large peplos-like veil, which extended down over the shoulders of the statue. The face is very regular, of classical type with straight, almost vertical brow- and nose-line; deep eyes and clean forehead. The hair is parted in the middle. The face was moulded. Height 15.1. Total width 14.3. Temples 4.2. I 14. 29.5.
671. Lower part of a statue of dark terracotta; broken off at the knees. Carefully folded chiton reaching the ground; himation with wavy edge above the feet. Height c. 20.0. Width 29.0. H 14. 29.5.
672. Lower part of life-size terracotta statue; broken off at the knees; right foot missing. Irregular base; right foot slightly advanced; vertically folded chiton reaching the ground; obliquely folded himation wound across body. Height 29.5. Width 34.0. I 14. 30.0.
673. Body of a terracotta statuette of the same type, as No. 774. Right hand holds a small bird; arched edge of himation above feet. Head and feet missing. Red painted himation. Length 56.0. H 15. 27.0.
674. Part of body of female terracotta statuette; broken off at neck and waist; right forearm and four fingers on left hand missing; wheel-made body, somewhat depressed over the breast. Both arms raised over the breast. The chiton somewhat folded around the upper edge below the neck; over left shoulder hangs a himation wound across the body leaving right side of breast uncovered. Back-hole. Height 31.0. H 14. 28.5.
675. Male head of dark-brown terracotta; broken off at neck

- back of head missing. Oval face with prominent chin; straight mouth; large, straight nose, arched eyebrows; small, faintly modelled eyes with elliptical lids, low forehead. Hair carelessly marked by short, incised lines. Height 19.0. G 14. 27.0.
676. Child's head of soft, white limestone, broken off at neck. Chin, nose, and right eye slightly scratched. The head is turned a trifle to the left. Oval, carefully sculptured face with rounded outlines. The technique is very soft without any deep depressions, or prominent parts. Nose is short and wide; eyes sculptured in a peculiar way with gently curved lids, but without eyeballs. The forehead is high and rounded. The hair is half long and arranged in a peculiar way; from front to occiput, a plait runs over the crown. On both sides of this plait, curls run following the plait. On the sides, the wavy hair falls down, ending in small spiral curls, which cover half of the ears. Traces of red paint on the hair. The face seems to have been painted yellow. Height 17.0. Temples 9.2. Forehead to back 14.5. E 13. 33.8.
677. Male head of dark, brown terracotta, broken off below chin. Almost triangular face, sculptured in a very primitive technique with a stiff, small mouth; straight, prominent nose; sloping forehead; very deep eyes with elliptical lids; deep, almost concave cheeks; front-hair roughly conventionalized with short, vertical incisions, sloping occiput. Double wreath in hair. Face covered with a red, somewhat lustrous slip. Height 19.0. H 14. 27.5.
678. Male head of coarse, red terracotta, black inside, and covered with a red slip. Broken off at neck. The crown of the head missing. Nose chipped. The face has a very curious, concave shape with prominent chin, and a small dimple in the centre, indicated by a vertical line; small, stiff, straight mouth; vertical nose; concave cheeks. The eyes are deeply set, slightly oblique, elliptical with sharply marked lids and brows. Above the low forehead, the hair is straight cut, the curls being marked by means of vertical, incised lines. Around the crown, there is a wreath of buds. Large, schematical ears placed close to the eyes. The head is hand-made, face modelled. Height 27.5. Total width 17.3. H 14. 27.0.
- 679 - 807
Female statuette of grey terracotta. Lower part and right hand missing. The head (No. 679) was found apart from the body (No. 807), but in the same pit. The body was made on a potter's wheel, but afterwards flattened and roughly worked over. Body is tubular with the female breasts faintly marked as projections; long, clumsy neck; face is made in a mould, very archaic expression; smiling mouth; prominent, straight nose; oblique eyes in shape of myrtle-leaves. On both sides of neck, plaits hang down to the shoulder. Above the arched, conventionalized front-hair, there is a high diadem composed of buttons and leaves. As regards the dress, only an oblique fold from left shoulder to right hip can be distinguished. The statuette has a pointed cap. Circular hole on back. Height 65.7. H 28.0.
680. Female head of yellow terracotta; broken off below chin; back of head missing; a piece of left side of head restored in gypsum. Oval face made in a mould, resembling No. 807; accentuated, archaic smile, prominent nose; eyes in shape of myrtle-leaves; evenly modelled; sloping forehead. Front-hair conventionalized in a zigzag line. Only the edge of the head-dress preserved, provided with upright leaves. Large bell-shaped ears. Height 15.5. H 14. 31.0.
681. Body of a terracotta statuette of the same type, as No. 774; upper part with breast, and lower part missing. Height 32.0. H 14. 29.0.
682. Five bronze nails. Length about 14.0. E 13. 33.8.
683. Female head of red terracotta, broken below neck. Back of head missing. Wide, tapering neck with horizontal wrinkles; oval face; sloping chin; aquiline mouth; straight nose; realistically sculptured eyes, rather deep set. Face probably made in a mould but carefully worked over. Height 11.3. G 15. 24.5.
684. Head of dark terracotta. Face is entirely worn away. Height 12.5. G 15. 24.0.
685. Male head of yellow terracotta; broken off obliquely at neck; carefully modelled, oval face; prominent chin with small dimple in the centre, somewhat aquiline mouth; thin, straight nose; elliptical, naturalistic eyes with iris marked by a faintly incised circle; straight clean forehead. Short hair, indicated by short, irregular impressions made with a pointed instrument. Above the crown, a wreath composed of small leaves; plain, concave ears. Apparently the head had been made for a female figure: on left side, a piece of the hair is missing; below this, there is another sculptured layer with other hair made in a different technique. Alterations can be seen also on the neck, where a second layer of clay has been added subsequently. This explains the female expression of the face. The hair and the wreath show that the head in the present state is male. Height 18.3. H 14. 25.4.
686. Female head of dark brown terracotta; put together from many pieces. Back part of head missing. Parts of the sides repaired with gypsum. Tip of nose damaged. Carefully worked face of classical type, made in a mould and subsequently worked over. Oval face with aquiline mouth; straight nose; gently curved forehead with slightly prominent middle. Realistic eyes, but without modelled iris. Height 24.7. H 14. 24.7.
687. See No. 665. H 14. 27.8.
688. Terracotta head in "snow-man" technique, broken off at neck. Plaits on either side; conical helmet. Height 5.2. H 14. 31.5.
689. Right foot of a more than life-size terracotta statue. Low, heavy, red painted boot with somewhat pointed and upturned tip. The boot is tied with a carefully sculptured, black rosette over the ankle; over this hangs

- a small tongue. A fragment of left foot is also preserved. Length of foot 32.2. E 13. 31.0.
690. Terracotta horse; part of chariot-group; legs partly missing; long, straight neck with a piece of the yoke. Length 9.5. E 12. 32.5.
691. Female head of *poros* limestone; broken off at neck; face entirely worn away; hair parted in the middle, visible in front below a veil which hangs over the head. Height 14.5. E 12. 34.5.
692. Female head of brown terracotta, broken off below neck; oval face made in a mould, somewhat irregular in shape; gently curved chin and cheeks; small mouth; long, straight nose and realistic eyes. Front-hair arranged in an arch above forehead and crowned by a diadem; small disc-shaped ears. Height 16.8. L 15. 40.0.
693. Male statue of hard, yellow limestone. Upper part from the breast with left upper arm missing. Small, irregular base with sloping upper side; almost straight legs; upright body. Right arm along the side; left forearm raised to the breast, the hand holding the end of the himation which hangs down from left shoulder. Folded chiton with sleeves to the elbows; himation wound around the body reaching the feet. The whole body is flattened; the lower part of the legs not sculptured free from the background. Flat, unsculptured back. Height 56.0. Breast to back 9.4. D 10. 36.0.
694. The face of a female head in dark-red terracotta. Prominent, sloping chin; small, smiling mouth; concave nose; almond-shaped eyes with arched eyebrows; hair parted in the middle. Height 10.5. E 15. 26.5.
- 695-739. Male statue of hard, grey limestone. Right hand missing; left side of head damaged. Thin, trapezoid base. Right leg slightly bent; upright body; right forearm raised; left arm bent to hold the end of the himation. The head, on a short, wide neck, is round and carelessly sculptured. Short hair. The male figure wears a folded chiton, and a himation wound across the body hanging over left shoulder; the ends of the himation are held by left forearm. Flat, unsculptured back. Height 40.4. Shoulders 14.0. Breast to back 6.5. C 9. 28.0.
696. Head of a horse in soft, white limestone, broken off at neck. The neck is comparatively thick; small head with short nose. Length 7.0. C 8. 28.0.
697. Terracotta sculpture similar to Nos. 888, and 891. B 11. 27.0.
698. Female head of dark-brown terracotta, broken off at the neck; back of head missing; oval face made in a mould; rounded cheeks and chin; aquiline mouth; straight, long nose; realistic eyes; straight, high forehead. Hair parted in the middle and combed backwards; back of head covered by a veil. Above the forehead, there is a bundle of flowers fixed in the hair. Height 14.5. D 12. 28.0.
699. Male statue of hard, grey limestone, containing many shells of various kinds. Feet, head, right arm, and left forearm missing. The figure rests on left leg, with right leg slightly bent and advanced; upright, fat body, the details of which are clearly visible below the himation. Right arm was held along the sides and sculptured free from body. Left arm bent close to the side, the hand holding the end of the himation, which hangs down from the left shoulder. Left part of breast bare. A deeply folded himation reaching almost to the feet is wound around the body. Its end hangs down over left shoulder. The legs are only partly sculptured out of the block of stone. Unsculptured back. Height 39.5. Shoulders 19.0. Breast to back 10.8. E 10.
700. Seated sphinx of soft, white limestone. Part of the base, forelegs, ends of wings, and head missing. The sphinx is seated on an oval base with a small tail curled up on the back; the body is curved. The base of the wings sculptured with zigzag notches. On the upper parts of the wings, the feathers are marked by incised lines. The front-part, or breast of the sphinx is flat, and there are no signs of forelegs. As there are traces of red paint on this flat front it may be suggested, that there was a place for some painted inscription. Height 14.3. F 10.
701. Torso of female statue of hard, yellow limestone, broken off at the knees, and through upper part of breast; surface worn. Upright body. Right forearm raised in greeting; left arm bent, the hand holding a fruit. The female breasts are faintly visible below the dress. Vertically folded chiton, the edge of which is seen just below the neck. The himation seems to have hung over the head. It comes down over both shoulders and is wound around body and arms; the end being held over left arm. Flat back. Height 34.5. Shoulders 19.5. Breast to back 9.0. E 11.
702. Female statue of soft, white limestone. Head missing. Small, sloping base; isolinear feet; straight, upright body. Left arm along the side; right arm folded across the breast, the hand holding a flower. Long, plain chiton reaching the ground. Plain himation over left shoulder to below the knees. Flat back. Height 21.5. Shoulders 7.2. Breast to back 4.2. D 11.
- 703+1020. Male statuette, probably representing Apollo; soft, white limestone; broken at the knees; arms missing from elbows. The head (No. 703) was found apart from the body (No. 1020), and the joint is rather worn. The left leg is slightly advanced; body upright with head looking straight forwards. The upper arms are held to the sides. Fractures on the hips indicate that the forearms were slightly bent and at the sides. The face is much worn, but shows a late archaic type with a faintly smiling mouth; elliptical eyes without lids; straight front- and nose-line; plain ears; the long hair is combed backwards and falls over the back of the neck. Wreath of myrtle-leaves in the hair. The back of the statue is vigorously sculptured. The statue wears a long shawl hanging over both shoulders to about the

- middle of the thighs, with vertical folds on the front and large semicircular folds on the back. The shawl leaves the front of the body with navel and male organ uncovered. Height 31.8. Shoulders 12.5. Breast to back 6.5. D 10.
704. Nude, male statue of hard limestone, broken off just above the knees; right arm, left hand with part of forearm, and head missing; the statue is made up from many pieces. Left leg slightly advanced; right arm and left forearm sculptured free from the body; left arm along the side. The body is fat, three-dimensional, and realistically sculptured all round. Height 46.5. Shoulder 23.0. Hips 16.6. Breast to back 12.0. E 7. 37.0.
- 705-723.
Male statue of hard, grey limestone. Right hand and left side of head damaged. The head (No. 723) was found apart from the body (No. 705). Small, rectangular base with sloping upper side. Left leg straight, right leg slightly bent, upright body; left arm along the side; right forearm raised in greeting. Short, thick neck with horizontal wrinkles. Round, full face with sloping chin; powerful mouth; short, strong nose, slightly scratched; eyes are deeply set and sculptured with arched lids; short, conventionalized hair. Wreath of myrtle-leaves in hair. The male wears a short, folded chiton. A himation over left shoulder is wound across the body, reaching to below the knees. The legs are not sculptured free from the background; right hand is also strengthened at the back by a part of the stone joining the hand with the shoulder. Height 56.5. Shoulders 15.6. Breast to back 8.3. E 6.
706. Nude, male statue of hard, grey limestone; feet, arms, and head missing. The statue is vigorously sculptured and three-dimensional, though the back is neglected. Many cavities in the surface. The statue rests on right leg, with the left leg advanced; the body is upright and slightly turned right; right arm akimbo; both arms sculptured free from body. The muscles are realistically worked all over the body. Between the legs, a thick piece of the stone has been left, evidently for the purpose of strengthening the legs. In spite of this, the statue broke, through the lower part of the legs probably when the sculptor worked on it. It has been mended by means of pegs put into three holes in the legs. The corresponding piece with the feet was not found. Height 39.0. Shoulders 16.7. Breast to back 10.2. E 7. 38.0.
707. Male head of a large statue in hard, yellow limestone, broken off at neck. Surface much worn. The head seems to be of a Hellenistic type, similar to No. 616. Short hair and wreath composed of laurel-leaves in the hair. Height 24.5. E 7. 36.5.
708. Female head of dark-red terracotta, broken off below neck. Nose and back of head damaged. Oval face with prominent chin; small aquiline mouth; straight nose, small eyes with elliptical lids marked as relief lines; iris indicated by means of a small circle in relief. Hair is covered by a veil, which hangs down back, with folds on either side of neck. The face hand-made and very roughly smoothed. Height 21.5. F 10. 9.0.
709. Male head of coarse, red terracotta; ears and right side of wreath missing. Broken below the extreme long neck. Oval face with pronounced chin; very small mouth; long, straight nose; receding, slightly curved forehead; realistic eyes with lids. Short hair visible as a thin roll below the laurel wreath which is wound round the head. The face seems to be modelled. Height 18.5. Temples 6.6. F 10. 8.0.
710. Male head of red, gritty terracotta, well-baked and covered with a pink slip. Broken below neck. Short, concealed neck; oval face with prominent chin; straight, very faintly smiling mouth; straight, almost vertical nose and clean forehead. The eyes are rather deeply set, elliptical, with lids. Small, schematical ears. Short, curly hair framing in the forehead. Laurel wreath visible in the hair. The back of the head is flattened. The head seems to be entirely hand-made, as there are no traces of a mould in the face. Height 19.85. Total width 11.5. Temples 9.0. E 9-10. 9.5.
711. Male statuette of soft, white limestone. Left foot and head missing. Isolinear feet; upright body; arms straight along the sides. The statuette wears a long, plain chiton reaching the ground. Over both shoulders, hangs a short, red-painted himation with sleeves to the elbows and open over breast and abdomen. Flat, unsculptured back. Height 17.4. Shoulders 5.7. Breast to back 2.4. E 10. 9.0.
712. Male statue, possibly representing Apollo, of soft, white limestone, broken off at the knees and about the hips. The left leg is slightly advanced. The piece shows a style unusually realistic for Cypriote sculpture. The knees are carefully worked as well as the muscles on thighs and body. The statue is draped in a himation which hangs down on both sides with vertical folds, leaving the front of the body with the navel and male organ uncovered. The back of the statue is also carefully sculptured, but now slightly worn. Height 24.0. E 9. 15.0.
713. Male head of gritty, red, well-baked terracotta covered by a red slip, on which the dark paint is laid. Broken off at the neck. Nose chipped and some leaves in the wreath missing. The face has a somewhat triangular shape with a pointed chin, small, smiling mouth with thin lips, large projecting nose; eyes without modelled lids; large, fairly naturalistic ears with thin earrings. The short hair is marked by a pinched, relief ribbon round the forehead, and at the back of the neck. A laurel wreath crowns the head. It is modelled leaf by leaf. The head is hand-made and the face is probably made without a mould. Height 16.5. Total width 12.0. Temples 8.5. E 9. 9.5.
714. Bearded head of greenish-grey terracotta, broken off at the neck. Oval face; smiling mouth; straight nose;

- half-moon-shaped eyes without lids. High, conical cap or helmet. Height 5.6. E 9. 19.5.
715. Left foot of a terracotta statue of at least life-size. Rounded, oval shape of shoe; painted red. Length 27.6. F 10 8.5
716. Fore part of terracotta horse; solid, made in a mould; broken off across body; forelegs missing. The horse is galloping with the legs uplifted; narrow head and nose, eyes sculptured on the sides; wide, open nostrils. Height 8.6. E 10. 12.0.
717. Male head of soft, white limestone with grey patina, broken off below neck. The face shows a late archaic type with a faint smile. Good workmanship. The neck is short and strong, the face very regular with slightly prominent nose (tip broken), eyes with lids in shape of myrtle-leaves. Ears sculptured with an incised line along the edges. The front-hair is parted in the middle, and is half long at the temples, and on the back, where it hangs down in vertical plaits, or curls. Over the crown, the hair is marked by straight grooves radiating from a central point. Myrtle wreath around the head. Height 16.2. Temples 6.5. Forehead to back 10.3. E 10. 10.0.
718. Terracotta mask representing a satyr with large mouth; wide nose; eyes with arched eyebrows. Height 5.9. F 10. 14.8.
- 719+743. Flat, male statue of soft, yellow limestone. Feet with part of the legs missing. The head (No. 719) was found apart from the body (No. 743). Straight, upright legs and body. Right arm along the side; left arm bent, the hand holding the forelegs of a buck, the hind legs of which hang down at the side of the statue. Head of buck broken and missing. The face is oval with sloping chin, faintly smiling mouth; eyes without lids, in shape of myrtle-leaves; low forehead; conventionalized front-hair; on the crown, the hair is indicated by zigzag notches. On the back of the head, the hair is long and marked with incised net-work pattern. Long, plain chiton with sleeves to the elbows. From the left shoulder hangs a plain himation with vertical edge on the left side. Flat, unsculptured back. Height 41.3. Shoulders 11.5. Breast to back 5.0. F 10. 7.0.
720. Female head of brown terracotta; broken off below neck; back of head missing; pieces of forehead and chin restored. Oval face made in a mould; classical type. Straight nose; eyes with carelessly worked lids. Small ears placed on the hair at the sides. Hair marked by means of incised dots. Wreath of laurel-leaves in hair. Height 17.7. E 10. 7.5.
721. Female head of yellow terracotta, broken off below neck; back of head missing; face partly damaged. Rounded face; smiling mouth; deep eyes with lids; sloping forehead; hair parted in the middle and combed backwards, marked by deeply incised lines. Height 18.0. E 10. 13.5.
722. Male head of dark-brown terracotta. Only the face with part of hair preserved. Face made in a mould; prominent chin, small smiling mouth with a thin moustache; straight nose (tip broken); faintly modelled eyes. Front hair conventionalized in a line of small, circular discs. The hair over the skull is indicated by parallel grooves. Height 18.7. D 9. 27.0.
723. See No. 705. D 9. 28.5.
724. Small, female terracotta head; made in a mould; broken off below neck; oval face of common type; hair parted in the middle and partly tied in a knot above the crown. Height 4.4. D 9. 30.0.
725. Female(?) head of light terracotta, broken off below neck; roughly sculptured, concave neck; oval face with faintly smiling mouth; eyes without lids, in shape of myrtle-leaves; front-hair conventionalized in small, vertical curls. Face apparently made without a mould. Height 7.6. F 10. 7.5.
726. Upper part of a terracotta arche made in "snow-man" technique. Plaits on either side; conical helmet. Eyes and hair painted black; body and helmet painted red. Height 7.1. F 10. 5.5.
727. Head of hard limestone, broken off at the neck. The head is slightly directed forwards. Horizontal fold on the neck marked by an incised line. Face is oval with prominent chin and full cheeks. Straight front-and nose-line; low forehead and wide temples, carelessly designed; short hair and ears just marked. Back of neck unsculptured. Surface coarse, especially over the forehead. Height 10.6. Temples 5.8. Forehead to back 8.0. F 10. 5.0.
728. Female face only of greenish clay; prominent nose and deep cut features; roughly applied ears set rather far forward. Hair in small waves across forehead. Dark-brown paint on hair and eyes. Height 10.5. F 10. 4.5.
729. Terracotta horse; legs missing; part of a chariot-group. The horse is galloping with the neck upright. Length 14.5. F 10. 4.5.
730. Bead, multi-coloured glass; pierced. Length 0.7. E 11. 30.5.
731. Bronze coin. *Obverse*: bust of Gordianus, r.; laureate; draped; around, inscription IMPGORDIANVS PIVS FELAVG. *Reverse*: Fortuna, standing; face to the left; holding cornucopia in left hand; right arm leaning on sceptre; around, inscription FELICIT TEMPOR; left of figure, S; right of figure, C. Diam. 3.1. Weight 19.6. Stray find. Surface.
732. Bronze coin; illegible. Diam. 1.5. Weight 2.7. Stray find. F 12.
733. Bronze rod; one end bent into a semicircle. Length 5.7. Stray find. F 12.
734. Upper part of a head in soft, white limestone. Face totally damaged. Conventionalized front-hair with wreath composed of ivy- and laurel-leaves; conical cap, the top of which is broken. Height 19.4. F 12. 20.0.
735. Upper part of female terracotta statuette; parts of arms missing; flattened body; small, female breasts; face of archaic type with plaits on either side; conical head-dress with upturned edge. Height 12.6. F 12. 20.5.

736. Female head of dark-red terracotta. Upper part of forehead, right temple, and side of neck missing. Oval face made in a mould; classical type; aquiline mouth, straight nose; deep, realistic eyes. Height 12.4. F 11. 12.5.
- 737-823. Flat, male statue of soft, white limestone. Feet and right hand missing; head damaged on both sides. Right leg seems to be slightly advanced; upright body; both arms slightly bent along the sides; left hand holding the forelegs of a buck, the hind legs of which hang down on left side. Head of the buck worn away. The neck is short and strong; face with slightly smiling mouth. Eyes with lids, in shape of myrtle-leaves; conventionalized front-hair; short hair on the nape of the neck; wreath of myrtle-leaves in hair. The man wears a long, vertically folded chiton with sleeves to the elbows. From left shoulder hangs a long himation with oblique folds across the body. The folds are indicated by means of incised grooves. Flat, unsculptured back. Height 50.0. Shoulders 18.0. Breast to back 8.0. F 11. 16.0.
738. Female head of dark red terracotta; broken off below chin; left side with top of crown partly missing; left eye damaged. Oval face made in a mould and subsequently worked over. Aquiline mouth with short upper lip, straight nose, slightly prominent middle of the forehead; eyes naturalistically sculptured, but without modelled iris. Hair arranged in melon rolls, separated by incised lines, each provided with short, incised lines. The back of the head was probably covered by a veil, the fracture of which is visible on right. Small pendants in the ears. Height 12.8. O 18. 30.0.
739. See No. 695. A 19. 30.0
740. Inscribed plaque of white marble, broken in two pieces fitting each other. The upper edge with thickened cornice; the other edges chipped. The letters are arranged in two lines with an incised line below the second. (See Appendix III) Height 32.0. Width 22.7. Thickness 5.3 G 22. 12.5.
- 741-1017-1021. Male statue of soft, white limestone. Lower part from the thighs, and right forearm missing. Broken in many pieces. The head (No. 1021) was found apart from the body (Nos. 741 and 1017). Upright, straight body; arms close to the sides; left hand holding a bird (now almost entirely missing). The face is badly worn; almost vertical brow- and nose-line; eyes deeply set and sculptured without lids. Conventionalized front-hair, and short hair on the back indicated by means of incised lines, making a net pattern. Wreath composed of myrtle-leaves and fruits in the hair. Vertically folded chiton and himation hanging over left shoulder and wound around the abdomen. The folds indicated by means of fine grooves. Flat back. Height 39.0. Breast to back 5.9 F 11. 3.5.
742. Male statuette in soft, grey limestone, sitting in the usual "temple-boy" fashion. Right side badly damaged. Right hand holds a bird. Flat back. Very sumptuous technique. Height 13.0. F 10. 14.0.
743. See No. 719 F 11. 8.5.
744. Torso of a male statuette in soft, white limestone. Broken at thighs. Right forearm and head missing. Left arm was held along the side. Left forearm folded over the breast, the hand holding the end of the himation. The statue wears a short-sleeved chiton with folds marked by incisions. Over left shoulder hangs a long, vertically folded himation, oblique over the abdomen. One end of the himation is held by left arm. Both chiton and himation have red painted borders. Height 17.0. Shoulders 7.8. Breast to back 3.8. F 11. 10.5.
745. Female head of brown terracotta, broken off below nose. The face is badly damaged, chin and nose partly missing. The mouth was naturalistically sculptured; eyes with modelled lids; wide forehead, above which the hair is marked by means of irregularly placed punctures. On the hair, at the sides, very small ears are placed. Wreath in hair. The head was made separately from the body and fixed to it by a revetment of clay. Height 23.0. C 8. 28.0.
746. Badly worn head of soft, yellow limestone, broken off at neck. Rough technique. Vertical nose; curled front-hair and myrtle wreath in the hair. Flat back. Height 8.6. Temples 4.6. Forehead to back 4.3. C 8. 29.0.
747. Head of terracotta idol; broken off at neck; plaits of hair on either side; conical head-dress. Height 6.1. C 8. 15.0.
748. Terracotta idol; head and one arm missing. Hollow conical base; cylindrical body; wide shoulders. Height 14.2. C 8. 15.0.
749. Male head of very soft, white limestone with many cracks. Right side of forehead with right eye and nose missing. Head is broken off below the chin. Face is oval and shows an archaic type with a faintly smiling mouth; eyes in shape of myrtle-leaves without lids. Large, plain, disc-shaped ears. The front-hair is stylized, curled horizontally. On the back of the head, the half long hair falls down in vertical curls. The hair over the crown is marked by straight grooves radiating from a central point. On the left side, a part of a wreath in the hair is visible. Height 7.8. Temples 4.7. Forehead to back 5.5. C 8. 32.0.
750. Block of sandy limestone much chipped and worn. On one side, there is an inscription in one line (See Appendix III). At the end, the inscription is broken. Height 19.2. Length 51.0. Width 34.0. D 15. 31.5.
751. Inscribed block of soft, grey limestone. Surface badly worn. The block is a slightly tapering, truncated pyramid. The letters are written on one side, in four lines on the upper half (See Appendix IV). Height 60.5. Width 20.5. Thickness 21.0. D 15. 31.5.
752. Male head of gritty, red terracotta, covered with a pink slip. Broken off at neck. Right ear, hair-curls, and piece of wreath missing; nose slightly chipped. Rounded face with full chin and cheeks; small dimple in the cheeks. Laughing mouth; short, broad nose; large eyes, distinctly

- modelled with lids, incised iris, and pupils; high forehead with a horizontal wrinkle; naturalistic ears. The short hair is carelessly curled and is held by a thick ribbon wound through the leaves round the head. The ornamentation on the ribbon is made by means of small dots. The head and face are entirely modelled. The terracotta is very thick so that the head is almost solid. Height 17.8. Temples 8.6. F 21. 35.0.
753. Terracotta horse, sculptured in a rude technique; legs partly missing; long, clumsy body; upright neck; very small head with button-shaped eyes. Male genitalia sculptured. Cf. the similar horse No. 850. Height 9.5. E 15. 32.0.
754. Terracotta rider, as No. 900. Rider broken off. Height 10.5. E 15. 32.5.
755. Male head of hard limestone with small holes and shells. Broken off below neck; short, concave neck with a horizontal fold below chin; face looking forwards. Sharply cut mouth and eyes with prominent, arched upper eyelids. Ears carelessly worked. Short hair, curls marked by series of semicircular grooves. Nose and upper right side damaged. Height 11.8. Forehead to back 8.6. F 16. 31.5.
756. Cock of soft, white limestone on a small irregular base, partly broken. Head missing. The cock is sitting with lowered wings and arched tail feathers. Red painted legs and claws. Height 9.8. C 20. 38.5.
757. Male head of coarse, dark-red terracotta, brownish-black inside and covered with a thin, red slip. Only the face is preserved, broken straight across the crown to the front part of the neck. Nose and chin chipped. The face is oval with full cheeks; sloping chin; small, sensitive mouth; straight nose; deeply lying eyes of naturalistic shape. Short, curly hair, — worked as irregularly placed impressions made by a pin, — frames the forehead. A wreath (now missing) was placed around the crown. The head seems to be entirely hand-made; face modelled. Height 17.8. Temples 10.4. E 19. 33.5.
758. Female head of dark, coarse terracotta; broken off below neck. Nose and mouth damaged. Thick neck, tapering upwards; oval face; prominent chin; wide nose; deep eyes with elliptical, thick lids and convex eyeballs; prominent brows. Front-hair marked by parallel incisions; small, shell-shaped ears. The head wears a round hat with moulded edge and convex upper side. The whole head is covered by a thick, red slip. Height 20.0. Temples 6.5. E 19. 34.2.
- 759 + 787 + 905 + 975.
Bearded statue in dark terracotta; made in two halves; large pieces of the lower half restored, especially on back; pieces of the upper half, too, restored — on body, right elbow, and a large piece on left shoulder. The head is joined to the body at a clean break on right side. Feet and right thumb missing. Left leg slightly advanced; straight legs; upright body; left arm bent across body; right forearm raised in greeting; powerful breast and shoulders; cylindrical neck; oval face with long, plain, full beard and moustaches; small mouth with faint, archaic smile; straight nose; oval eyes with faint, incised lines indicating lids. The front-hair is very conventionalized with small balls of clay along an arched line above the forehead; wreath in hair. Long, plain chiton reaching the feet; over left shoulder hangs a plain himation which ends at the knees with an oblique edge. Back-hole on upper half. Height 175.0. Shoulders 56.0. Breast to back 23.0. Point of beard to crown 25.7. H 15. 28.5.
760. Upper part of a female head of the same type, as No. 813. Lower part of head with right eye missing. Over the conventionalized hair which was originally made in a mould, a row of small spiral curls had been added subsequently. Most of the curls are now missing. Height 12.0. G 16. 29.5.
- 761 + 800 + 818 + 950.
Life-size, male terracotta statue made in two separate halves. It is not absolutely certain that the parts originally belonged to the same statue, but as they exactly fit each other, a description of the whole statue may be justified. Left forearm and fingers of right hand missing. Parts of the neck are also restored, but the original break at the neck was ascertained on the right side, near the back-hole through the neck. Other minor pieces are restored on back, and back of right upper arm. — Small, irregular base; almost isolinear feet, upright body, and head looking forwards; right forearm somewhat raised in greeting; left forearm, too, was somewhat raised; it was made separately and fixed to the upper arm by means of a peg, whose hole is preserved on the upper arm. Head almost round and provided with a full, curly beard and moustaches; thin, straight nose; faintly modelled eyes without sculpturally marked lids; front-hair hangs in small, vertical cork-screw curls over the forehead. Wreath of ivy-leaves in hair. Large boots with rounded, upturned toes, and trefoil tongue; long vertically folded chiton with short sleeves; leaving most of the breast uncovered, a himation hangs over left shoulder to about the knees, wound across the body with carefully waved edges hanging from left elbow. Two back-holes on upper part, and three on lower. Height 167.0. Shoulders 48.5. Breast to back 27.0. Point of beard to crown 28.0. G 15. 28.5.
762. Lower part of terracotta statue; fragmentary. G 16. 26.0.
- 763 + 766.
Female statuette of brown terracotta. Left hand and back of the head (No. 763) missing. Face badly worn. Wheel-made, trunk-shaped body slightly depressed from in front. Female breasts faintly marked. Right forearm raised in greeting; left arm folded over the breast. Head made in a mould; oval face; smiling mouth; thick nose; conventionalized front-hair; above ears, hair is curled up and fixed in connexion with disc-shaped ear-pendants. Plaits on the sides of neck. On the head, a conical cap, as No. 851, though partly miss-

- ing. Long, plain tunic; two bracelets on each arm; necklace round neck. Circular hole in back. Height 62.7. G 16. 28.0.
764. Small, female statuette in grey terracotta, made in a mould. Archaic type. Isolinear feet; upright body, arms along sides; head looking straight forwards. Long-sleeved, vertically folded tunic gathered in at the waist by a belt. On the head, a veil which hangs down on either shoulder. Flat back. Height 10.0. G 16. 27.6.
765. Bearded terracotta statuette, evidently part of a chariot-group. Base was fixed to the chariot. Upright body, slightly bent forwards; probably he held the reins with his hands. The helmet is indicated by a band over the crown, held together by a horizontal band on the back of the head. Another central band runs from forehead to the back. Traces of red paint on body. Height 13.2. F 16. 27.6.
766. See No. 763. F 16. 25.0.
- 767 + 846 + 869 - 911.
Bearded, life-size statue in buff terracotta; made in two separate halves. The upper parts of the lower half are partly restored, and the connexion between the two halves is not absolutely certain. Between the breast and the neck, some pieces, too, are missing and there are no breaks to which the head could be attached. The clay, however, is very peculiar and rare among the fragments collected, so the restorations made seem certain. Left forearm missing. Right shoulder is restored in accordance with breaks preserved on the body, underneath the shoulder. — Almost isolinear feet; straight legs and upright body; very wide shoulders; head looking straight forwards. Right arm was raised in greeting; left arm was bent and directed forwards. Powerful neck; oval face with plain, black beard and moustaches; nose somewhat deformed; large, elliptical eyes, sculpturally marked with lids painted black as the eyebrows. Front-hair arranged in small, vertical cork-screw curls made separately and attached to the head; two plaits on either side of neck, painted black; ivy wreath in hair. Long, plain chiton reaching below the knees; half-length himation hanging over left shoulder, leaving both upper arms uncovered; vertical edges of himation hang from right elbow. Boots painted red. One back-hole in upper half. Height 168.5. Shoulders 62.0. Breast to back 20.0. Point of beard to crown 25.0. F 16. 23.5.
- 768 - 840 - 1014.
Large, bearded statue of greenish-grey terracotta, put together of sherds. The upper part of the head was found in the square N 17 on level 40.0; many fragments are missing, but have been restored in gypsum. The width of the shoulders was preserved; the position of the right arm, however, is conjectural as only the hand was found. The statue was made in two separate parts. The upper parts of the lower one are also restored in gypsum and its height therefore is conjectural. The statue originally stood on a thin terracotta tablet, a part of which is preserved between feet. The actual base is restored in order to keep statue upright. Stiff, upright body with very broad shoulders; left arm bent over body; right forearm raised in greeting; short, powerful neck. Rounded face with short beard, conventionalized in parallel rows of small curls; straight mouth; short, broad nose; faintly marked eyes marked by means of paint. The short hair arranged in two rows of small curls held together by a thick ribbon in the hair. The statue has heavy beaded around the ankle, with the knot on the front side. Long-sleeved, plain chiton to below the knees; on left shoulder hangs a plain himation leaving right side of breast and both arms uncovered. — Traces of paint all over the statue. Red painted boots; green himation; reddish hands; grey beard; reddish face with black eyes and eyebrows; black hair. Height 183.0. Shoulders 72.0. Height of head 25.0. G 16. 22.769 - 782.
Female statuette of pale terracotta. Back of head missing. The body (No. 782) was found apart, but not from the head (No. 769). Large feet with pointed shape projecting below the tunic; trunk-shaped body made on a potter's wheel; both arms held to the sides, right hand holding a small bowl with fruits, left hand holding a bird. The female breasts marked by two faint projections. The face, made in a mould, is round with a slight smiling mouth; clumsy nose; eyes with lids, in shape of myrtle-leaves; large, projecting ears; conventionalized front-hair; two plaits falling down to the shoulder. Pair well preserved; red shoes; black, bordered tunic; broad red band obliquely across body; black hair. Large circular hole on back. Height 54.4. H 15. 25.5.
770. Male statuette of dark terracotta; hands and head missing. Isolinear feet; straight legs; upright body; forearms stretched forwards; the hands were probably holding some votive offerings. Pointed, upturned shoes; long chiton with an arched fold above feet. A himation is indicated by means of various ridges on body; the himation hangs over both shoulders having right part of the breast uncovered, and reaches to below the knees. The whole body is covered with black slip. Back-hole. Height 70.0. Shoulders 29.0. H 15. 29.0.
771. Fragments of terracotta statuette, as No. 806. H 15. 28.0.
772. Female terracotta statuette of the same type as No. 667; broken off at breast and lower part about the knees. Height 40.0. Width 28.0. H 14. 31.0.
773. Body of a terracotta statuette of the same type as No. 667; upper part with breast, and lower part missing. Height 39.5. H 14. 29.0.
774. See No. 667. H 14. 28.0.
775. Female terracotta statuette of the same type as No. 667; lower part, and head missing; female breasts faintly marked; right hand holding a small bowl with fruits; plain, short-sleeved tunic. Height 40.5. H 14. 24.5.

76. Lower part of a terracotta statuette made separately from the upper part; wheel-made body, oval section. Red painted shoes (damaged). The chiton is finished with an arched fold above the feet. Height 37.0. H 14. 25.0.
77. Right forearm of a life-size statue in dark terracotta; the hand is bent upwards with the fingers carefully sculptured, somewhat bent. Length 29.0. H 14. 25.0.
778. Small terracotta bird. Part of a statue, to which it was fixed by means of a long peg at the back. Length 8.5. H 16. 27.8.
779. Terracotta horse, belonging to a chariot-group. Three legs broken; short, upright neck with short mane; part of the yoke on neck; short front cover. Height 11.5. G 15. 23.5.
780. Plain White VI miniature jug with flat base; rounded, biconical body; narrow neck; annular rim; handle (missing) from neck to body. Height 6.5. G 16. 25.5.
781. Fragments of circular bronze plaque. G 15. 30.0.
782. See No. 769. G 16. 24.0.
783. Fragments of lower part of a terracotta statuette with almost circular section. Height c. 17.0. G 15. 24.0.
784. Female terracotta statuette; wheel-made body somewhat flattened. Isolinear feet with large shoes; upturned tips; upright body; arms raised in greeting position; hands missing; small, female breasts marked. Face badly worn, made in a mould; archaic type with smiling mouth; eyes with lids in shape of myrtle-leaves; stylized front-hair; conical head-dress; several rings in ears. Long tunic just leaving the feet uncovered; over this a himation with a carefully folded edge just above the feet. Along the sides, heavy vertical folds run from the elbows downwards, ending in curiously out-turned tips. Trace of red paint on shoes. Small, circular back-hole. Height 53.6. Width 19.0. Breast to back 10.4. G 15. 26.0.
785. Female statuette of green terracotta. Trunk-shaped, plain body made on a potter's wheel and slightly flattened over the breast; very short arms along the sides; fingers bent; oval face made in a mould; small mouth; thick, prominent nose and eyes in shape of myrtle-leaves with faintly marked lids and eyebrows; conventionalized front-hair. Conical cap which ends in a knob provided with a hole; another hole in the back. Traces of red paint on the cap and on body; black painted hair. Height 80.0. F 15. 27.0.
786. Feet of a terracotta statuette, standing on an irregular base; narrow shape with pointed shoes. Height 14.3. Length of shoes 15.5. F 16. 24.3.
787. See No. 759. H 15. 28.0.
788. Bronze ring with circular section. Diam. 1.6. H 15. 31.0.
789. Bone bead; flat; pierced by a large hole. Diam. 1.7. H 15. Stray find.
790. Female statuette in soft, white limestone. Face missing. Isolinear feet on a sloping, small base; straight, plain body; left arm along the side; right arm folded over the breast, the hand holding the pendant of the necklace. Round head with plain ears and long hair falling down on the back. Long, plain tunic with long sleeves; bracelet with pendant. Traces of red paint on the tunic. Flat back. Height 20.5. Shoulders 6.7. Breast to back 3.6. G 16. 21.5.
791. Female statuette of soft, white limestone; standing on a small rectangular base; isolinear feet; flat, upright body; left arm along the side; right arm bent over the breast, the hand holding the pendant of the necklace. The head is looking straight forwards. The face is carefully sculptured with a smiling mouth; elliptical eyes without lids; straight front- and nose-line. Flat back. The front-hair is conventionalized and artfully tied up at the ears. The hair falls down over the nape of the neck. Plain ribbon in the hair. The statue wears red painted shoes and a long-sleeved tunic reaching the ground. Two necklaces with pendants around the neck. The tunic has red painted borders. Red paint is also traceable on the lips and on the ribbon, which seems to have been decorated with red dots. Height 18.8. Shoulders 6.9. G 15. 21.3.
792. Lower part of right leg of a terracotta statue, broken off below knee; base with rounded edge; rather carefully sculptured leg. Narrow type of boot with rounded point; the boot is tied around the ankle with a knot hanging over the foot; overhanging, trefoil, edged tongue. Height 34.5. Length of foot 16.0. G 15. 21.0.
793. Female statuette of yellow terracotta; lower part missing, but restored in gypsum. Both arms wanting from elbows. Trunk-shaped body tapering slightly downwards; arms somewhat bent along the sides of body; the female breasts indicated by small projections; head is looking straight forwards; face made in a mould, of the same type as No. 813; short plaits on either side of neck; conventionalized front-hair. Conical head-dress with upturned edge decorated with upright leaves. Eyes and hair painted black. Baking hole in back. Present height 57.5. H 16. 25.5.
794. Terracotta bull (?) with short, straight legs; upright neck; short, strong horns; tail along left hind leg. Right foreleg missing. Height 9.5. H 15. 25.0.
795. Female head of bright-red clay; face only preserved. Prominent nose and deep cut features; oval eyes without pupils; ears protruding and set far forward. Hair in even waves across forehead. Traces of veil behind. Dark paint on left eye and hair. Right side worn. Height 12.0. H 15. 25.5.
796. Lower part of cylindrical terracotta statuette; broken off at the knees; wheel-made; very small feet. Height 21.7. Width 13.4. H 15. 28.5.
797. Lower part of terracotta statuette, as No. 806. Height c. 30.0. H 16. 25.5.
798. Fragments of lower part of terracotta statuette with cylindrical body. H 15. 23.2.
799. Female head of pink terracotta; broken off below chin; left side damaged. Face made in a mould of a type similar to No. 813. Conical cap. Height 17.0. H 15. 26.5.

800. See No. 761. H 15. 25.0.
801. Lower part of terracotta statue; partly wheel-made body; circular, moulded base; depressed, cylindrical body. Long, plain tunic with arched edge above the feet. Feet naked with painted sandals. Nothing of arms preserved. Height 69.0. Width 24.2. H 15. 26.5.
802. Lower part of a flat, straight statue of hard, white limestone. Broken at the knees. Small, rectangular base with sloping upper side. Short feet. Chiton reaching the feet. Flat back. Height 24.0. H 15. 29.5.
803. Fragments of a terracotta statuette of the same type as No. 806. H 15. 26.5.
804. Lower part of large statue in greenish terracotta; possibly belonging to the same as No. 611; rather depressed from in front. Upright body; no feet, but an arched piece of terracotta is cut away from the front and possibly the feet were placed there. Several back-holes. Height 96.0. Width 45.0. H 14-15. 24.0.
805. Lower part of male head in pink terracotta, broken off below chin; upper part with eyes missing. Face sculptured in the style characteristic of the earlier statues from Ajia Irini; very pointed chin; straight mouth; thin, slightly upturned nose. Height 6.0. H 14. 27.5.
- 806-815.
Female terracotta statuette of the same type as No. 774. Left arm, neck, and lower part of face restored in gypsum. Right hand holds a small plate with fruits. The end of the long tunic arched above feet (feet missing). Height 85.0. Width of shoulder 29.0. H-I 14. 27.5.
807. See No. 679. H 14. 26.5.
808. Male head of white, hard limestone sculptured in a very vigorous technique. Head is broken through the very thick neck and slightly turned left. The face is almost round with full cheeks and chin; half-open mouth with thick, prominent lips. The nose is straight, almost projecting, and provided with deeply bored nostrils. The eyes are very deeply set and marked by a ridge for the place of the eyebrows. Prominent eyeballs, and arched, sharply marked upper, and almost straight lower eyelids. Hair and ears very roughly marked. Back is flat, unsculptured. Possibly the head was part of a relief. In any case the back of it was sculptured in a very rude technique. Height 13.5. Temples 7.3. G 22. 31.5.
809. Fragment of a male head; broken off obliquely through lower part of face. Carefully sculptured eyes with faintly modelled iris; short hair marked by irregular, incised lines; wreath of myrtle-leaves in hair, preserved on right side. Face made in a mould, but eyes and hair worked over afterwards. Width 12.1. H 23. 40.0.
810. Male head of soft, white limestone, broken at neck. Part of chin missing. The face is oval and shows a rather degenerate type. The faint smile is conventionalized. Straight front- and nose-line. Elliptical eyes with lids. The front-hair is stylized as zigzag ridges. The hair on the nape of the neck is short and carelessly worked. The head wears a wreath composed of ivy- and laurel-leaves. Height 17.5. Temples 7.7. Forehead to back 9.0. J 18. 43.0.
- 811-922-1034.
Flat, male statue of soft, white limestone; the body (No. 1034) and the head (No. 811) were found separately from the body (No. 922). Small, trapezoidal base with sloping upper side. Right leg slightly bent and advanced; upright body; arms comparatively short, held along the sides, right hand holding a branch, left hand holding the himation tight to the body. Oval face with a very faintly smiling mouth; large eyes, without lids, in shape of myrtle-leaves. Conventionalized, half-length hair. Wreath composed of ivy- and laurel-leaves in front. Long, vertically folded chiton with sleeves to the elbows. Hanging over left shoulder and wound around hips and thighs, obliquely folded himation held in right hand. Folds indicated by means of incised grooves. Flat back. Traces of red paint on the feet. Height 62.0. Shoulders 13.6. Breast to back 6.7. J 18. 43.0.
812. Male head of soft, white limestone with rather worn surface. Broken off below neck. Oval face of late classical type with a faint smile. Eyes in shape of myrtle-leaves and nose almost vanished. Myrtle wreath in hair. Height 12.0. Temples 5.5. Forehead to back 7.3. J 18. 43.0.
813. Female head of yellow terracotta, broken at neck. Oval face made in a mould; smiling mouth; thick nose; eyes with modelled brows, and lids in shape of myrtle-leaves; conventionalized front-hair. Conical cap with upturned edge. Height 17.3. J 18. 42.8.
- 814-816-926-979.
Group of greenish-grey, finely silted terracotta representing Athena mounting a chariot drawn by four horses. The group was found in many pieces scattered about; some of the missing pieces have been restored in gypsum. Thus, the base tablet, pieces of which were found, has been restored in wood and gypsum. The pieces of the horses could easily be supplemented as various parts of all the horses were found. Most of the hind part of the left, outer horse; all the legs of the left inner horse; and right foreleg and hind part of the right, outer horse are restored. As only very scanty remains of the right, inner horse were preserved this has been made new from casts of various parts of the other horses. Pieces of the chariot were found sufficient for a reconstruction of upper parts. Its height above the ground is, however, not certain, as no remains of the wheels were preserved. As to the figure of Athena only pieces of the breast on right side were absent. They were restored, but without the surface design of the *aegis*. The distance between the horses and the chariot with the figure of Athena is also conjectural. — The horses are all of a similar type: carefully worked with the muscles well accentuated; body long and narrow; thick, strong neck; small head, with narrow nose; carefully sculptured eyes with eyebrows; no mane.

The horses are bound together by a yoke on their backs; the outer horses have a girth, which, however, is missing on the inner horses. All the horses have two narrow breast-bands, the lower one with a small tuft. The reins are rather peculiar, as each horse is held separately by one rein, which divides just below the neck on either side of the head; the reins are fixed to a nose-band and cheek-piece. Probably only one pole ran between the chariot and the yoke, though there are two breaks on the body of the chariot. Probably these two parts joined one pole, which ran up between the inner horses. A fragment of the pole is preserved.

The body of the chariot is very small, the sides consisting of square supports with rounded-off corners and similar horizontal bars. At the corners there are palmettes. Athena is sculptured just mounting the chariot, with her right foot already placed on the bottom of the chariot, while the left still is on the ground. She is turned slightly to the right, with arms bent holding the reins. Possibly she was holding a spear in her left hand. Athena has a long, oval face, prominent chin; smiling mouth; large, elliptical eyes with exaggeratedly worked eyelids. The hair is carefully curled in vertical screw-curls hanging all round the head; the long hair falls down the back. Athena wears sandals; and an obliquely folded tunic reaching to the ground. Over shoulders and breast, the heavy *aegis* hangs ornamented with incised scale-pattern. Over the stomach, two snakes hang down below the *aegis*. On the head, Athena has a Corinthian helmet, pushed rather high up on the crown. The whole group, and especially Athena, is sculptured in a comparatively good, though dry and stiff, technique, different from other terracotta statuettes of Cyprus. Height of Athena 36.0. Height of horses c. 35.0. J 18. 42.8.

815. See No. 806. J 18—19. 42.5.

816. See No. 814. J 19. 42.2.

817. Male head of soft, white limestone, broken vertically in two pieces, fitting well together. Right side damaged. Oval face with full cheeks, straight mouth; wide, broad nose, almost vertical; flat, elliptical eyes without lids. Conventionalized front-hair; short hair on the back of the neck. Roughly sculptured wreath in the hair. Height 9.2. Temples 4.7. Forehead to back 5.0. J 19. 43.8.

818. See No. 761. J 19. 42.5.

819. Object of terracotta; probably a leg of a statue. Length 30.0. J 19. 43.0.

820. Large, bearded head of brown terracotta; broken off at neck; left side of face slightly worn. Oval face made in a mould; rounded beard; thin, hanging moustaches; thin, slightly concave nose; faintly modelled eyes; front-hair arched without modelled details; plaits on either side of neck. High, conical head-dress with out-turned edge. Wreath of laurel-leaves around the head-dress. Circular hole at top. Height 36.5. Temples 12.5. J 19. 42.2.

821. Upper part of male statuette in grey terracotta. Breast with head preserved. Upright, trunk-shaped body; arms held close to the sides; short, thick neck; rounded face with prominent chin; smiling mouth; short, broad nose (slightly damaged); elliptical eyes with lids; heavy, conventionalized front-hair; large, protruding ears. Short-sleeved tunic with thickened edge around neck. Wreath of ivy-leaves in hair. Circular hole through back of head. Height 27.7. J 19. 42.3.

822. Female head of coarse, red terracotta, darkened at the inner surface; well-baked and covered by a thin, red wash. Broken off below neck. Top of head-dress missing, left ear chipped. Oval face with full chin and cheeks; small mouth, faintly smiling; large, somewhat curved nose; long eyes with arched upper lids and brows, and almost straight lower lids; low, rounded forehead; conventionalized ears. A curly roll of hair frames the forehead; plain, conical head-dress; no diadem or wreath. The face is moulded and worked over. Height 15.6. Total width 10.0. Temples 7.25. J 19. 42.2.

823. See No. 737. J 19. 42.3.

824. Three terracotta horses belonging to a chariot-group. Evidently two horses are the middle ones. The hind part of the horses is modelled together with the chariot, of which only a part is preserved. On the neck of the right horse, a piece of the yoke is visible. Height 11.0. I 19. 41.8.

825. Lower part of a flat, female statue of soft, white limestone. Upper part from the breast, feet partly missing. Small, irregular base. The chiton is realistically folded with deep, engraved furrows. Flat back. Height 35.8. Front to back 5.0. I 19. 42.6.

826. Fragment of a chariot-group in soft limestone; broken off so that the fore-part of horses is missing; heads of drivers also missing. The backs of four horses preserved, galloping with tails outstretched. The chariot is wide and short, has wheels with seven spokes, and is divided in two compartments for two drivers who are standing upright with arms on the chariot case. They are draped in himatia with garland folds in front, and vertical folds on back. Between the drivers, at the back of the chariot is a post pierced at the upper end (cf. similar arrangement on most of the terracotta chariots). Height 15.0. J 19. 44.0.

827. Fragments of terracotta horses belonging to a chariot-group. J 19. 44.5.

828. Terracotta fragments, as Nos. 888, and 891. J 19. 44.8.

829. Terracotta statuette; part of a chariot-group. Probably the driver. Moulded face; flat hat. Height 9.0. J 19. 45.0.

830. Fragment of a female head of light red terracotta, of the same type as No. 813. Only upper part of left side of the face is preserved. Wreath of ivy-leaves in hair. Height 11.0. I 19. 41.8.

831. Head of terracotta horse; broken off at neck; nose and ears missing. Eyes faintly modelled; mane cut short; on the crown, there is a fracture of a plume, and a piece

- of the yoke is fixed on back of neck. Two reins on neck. Height 10.7. I 19. 41.5.
832. Male head of soft, white limestone, broken off with a part of the breast. Long, oval face with prominent chin, vertical brow- and nose-line; large, flat eyes without lids; conventionalized front-hair; short hair on the flat back of head, marked by incised lines making a net pattern. Wreath of laurel-leaves in the hair. Part of the vertically folded chiton visible on the breast. Height 21.3. Total width 9.3. Temples 7.1. Forehead to back 5.8. I 19. 41.5.
833. Female head of yellow terracotta, broken off at neck; back missing. Oval face, made in a mould; smiling mouth; thick nose; eyes without modelled lids. Front-hair arranged in small spirals. The head wears a cap, the edge of which is framed by upstanding triangles. Height 11.0. I 19. 41.5.
834. Torso of a small statuette representing a warrior. Soft, white limestone. Legs from the thighs, both arms with right shoulder, and head missing. The body is vigorously sculptured all round. Judging from the fractures, the arms were placed close to the sides. The warrior wears a cuirass reaching the waist. The cuirass is provided with rectangular plaques hanging down over the breast from the shoulders. Around the waist, there is a belt from which similar plaques, or scales hang down over the hips and thighs. Height 13.5. I 19. 41.5.
835. Fragment of a flat statue, probably male, in soft, white limestone. Only the middle of the abdomen is preserved with the elbows of the arms, which are close to the sides. Vertically folded chiton with short sleeves. Himation hanging from left shoulder, and wound around the body. The folds are indicated by means of incised lines. Flat, unsculptured back. Height 16.0. Total width at elbows 18.0. Abdomen to back 6.4. I 19. 41.5.
836. Front part of a hollow terracotta horse; broken off at neck and legs. Belongs to a chariot-group. Height 26.8. I 19. 39.0.
837. Fragments of warriors and driver belonging to a chariot-group of terracotta. I 19. 41.5.
838. Head of hard limestone, much mutilated. Height 17.0. I 19. 41.5.
839. Base for a statue of hard, white limestone. On one side inscription is carved with distinct letters, arranged in three lines (See Appendix III). Height 7.1. Width 11.4. Length 17.3. I 19—20. 42.5.
840. See No. 768. H 19. 41.8.
841. Upper part of statuette of pale, yellow terracotta. Only left shoulder and head preserved. Oval face with very faintly smiling mouth; thin nose; eyes with lids in shape of myrtle-leaves; curved forehead, roughly marked front-hair. In the hair, a wreath composed of ivy-leaves and fruits (damaged on right side). The male wears a vertically folded chiton and a folded himation hanging over left shoulder. The face is not made in a mould. Height 32.5. H 19. 41.4.
842. Male head of soft, white limestone; broken off at neck. The face is entirely damaged. The front-hair is conventionally curved. Over the crown and on the back of head, the hair is marked by means of zigzag notches. Wreath of laurel-leaves in the hair. Flattened forehead. Height 14.5. Temples 7.3. H 20. 41.3.
843. Male statue of soft, white limestone. Right hand missing, right shoulder, and head missing. Small, rectangular torso with sloping feet; upright body; right leg slightly advanced, left arm straight and close along body. Long, vertically folded chiton reaching the ground. Himation hanging over left shoulder, obliquely folded. The folds are indicated by means of incised grooves. Flat, unsculptured back. Height 42.0. Breast to back 5.2. H 20. 41.3.
844. Fragment of a flat statue of soft, white limestone. Broken off at the knees and above the feet. Left leg seems to be slightly advanced. At the lower end, a part of the vertically folded chiton is visible. Over this hangs an obliquely folded himation. The folds indicated by means of incised grooves. Flat back. Height 18.0. Total width 6.5. Front to back 3.9. I 20. 42.0.
845. Female head of coarse, red, well-baked terracotta; broken below neck. Nose missing; edge of veil chipped. Oval face with prominent chin; very small mouth; naturalistic eyes with lids and low, curved brows. Straight, high forehead and fairly realistic ears; however, of a certain volute shape. The hair is visible in front framing the forehead and leaving the ears free. The head wears a veil of peplos-type with the edge projecting above the crown. The face is moulded. Height 15.5. Total width 8.6. Temples 6.6. J 20. 43.5.
846. See No. 767. I 20. 40.0.
847. Fragment of a large terracotta statue. Part of the breast preserved. Height c. 47.0. I—J 20. 40.0.
848. Lower part of terracotta statuette; upper part with the breast missing. Similar to No. 806. Height 47.0. H—J 20—21. 39.0.
849. Terracotta statuette, similar to No. 806. Breast and feet missing. Height 46.4. Width 21.8. I 20. 40.0.
850. Terracotta horse of clumsy type; part of a chariot-group. Small head with button-shaped eyes. Height 10.3. I 20. 40.0.
851. Female head of brown terracotta; broken below chin. Round face made in a mould; archaic smile; short, thick nose; eyes in shape of myrtle-leaves; eyelids marked. The front-hair is faintly conventionalized; behind the ears plaits hang down. The head wears a conical head-dress with upturned edge. Height 19.2. I 20. 40.5.
852. Arrow-head of bronze; short socket; triangular shape. Length 4.5. I 20. 39.0.
853. Upper part of a large terracotta statue; arms and head missing. The body is wheel-made and depressed from in front. The arms were made separately and fixed with pins in holes below the shoulders. Three back-holes. On the breast, the surface layer of the terracotta is damaged. Height 60.0. Shoulders 5.9.6. Breast to back 22.2. I 20—21. 38.5.

- Fragment of a large, bearded head of the same type as No. 820. Only upper part of right side with nose and mouth preserved. Below the head-dress the front-hair is visible, the curls being marked as a line of circular buttons. Height 15.6. I 21. 38.2.
55. Pair of forearms of a terracotta statue, almost of life-size. The fingers are bent. Traces of red paint. Length 23.5 and 17.5. I 21. 39.0.
56. Flat, male statue of soft, white limestone. Head missing. Summary work. Small, irregular base; right foot just a little advanced; straight, plank-shaped body; right arm straight along the side; left hand holds a buck to the side of the breast. Vertically folded chiton reaching the ground, with sleeves to elbows. Over left shoulder an obliquely folded himation, extending to below the knees. Flat, unsculptured back. Height 49.4. Shoulders 12.2. Breast to back 4.8. I 21. 38.5.
57. Body of a terracotta statuette, of the same type as No. 774. Head and lower part missing. Height 43.5. I 21. 39.0.
58. Fragment of right leg of large terracotta statue; broken off above the ankle and above the knee; powerfully sculptured with very thick clay; hand-made. Height 32.5. I 21. 39.5.
59. Fragment of a terracotta head; only face preserved. Full cheeks; realistic eyes with incised lids and iris. Height 9.5. I 21—22. 38.5.
860. Male head of a statuette in "snow-man" technique; conical head-dress. Height 4.7. Stray find.
861. Bead of blue faience; striated sides; large string-hole. Length 1.2. Stray find.
- 862 a) Female head of dark, brown terracotta; broken off below neck; put together of many pieces; left side of head-dress damaged. Oval face made in a mould of a similar type as No. 822, but of smaller size. Conical head-dress with hole through the top. Small plaits on either side of neck. Height 23.5. I 21. 38.5.
b) Female statuette of grey terracotta. Upper part of head, and left forearm missing. Isolinear feet; wheel-made, trunk-shaped body slightly depressed in front; arms along the sides; breast faintly marked. Short, thick neck; oval face with clumsy outlines; thick lips; elliptical eyes with lids. Long, plain tunic with vertical, projecting frames on the sides. Black painted shoes; red tunic, traces of red paint preserved on the lower parts of the tunic. Circular hole in back. Height 41.7. I 21. In No. 653.
863. Terracotta head of the same type as No. 688. Height 7.4. H 20. Stray find.
864. Female head of yellowish terracotta, broken off below neck; back of head damaged. Round head made in a mould; pointed chin; smiling mouth; short, thick nose; eyes in shape of myrtle-leaves with arched eyebrows; conventionalized front-hair. Conical head-dress; plaits on either side of neck. Ears with small, double rings. Black painted eyes; hair with plaits. Height 21.8. J 19. 41.5.
865. Hind part of a large, hollow terracotta horse belonging to a chariot-group; cylindrical, wheel-made body; stiff, straight hind legs. Height 26.0. J 18—19. 43.5.
866. Male head of soft, white limestone, broken off at the chin. Oval face of late archaic type with a faintly smiling mouth, straight front- and nose-line, eyes with lids in shape of myrtle-leaves. The front-hair is conventionalized. Over the nape of the neck, the hair is half-long and falls vertically. Radiating lines over the crown. Height 12.8. Temples 6.8. Forehead to back 8.4. I 19. 40.0.
867. Female head of brown, very soft terracotta; broken off below neck with a part of the breast, back, and right temple damaged; surface of the face on left side has partly gone. The face is made in a mould, apparently the same as has been used for some of the Vouni sculptures. Comparatively thick neck; oval face with small, prominent chin; very small, smiling mouth; thin, straight nose, arched eyebrows, and faintly modelled eyes. Front-hair arranged in small, spiral curls visible below the head-dress, with a wreath composed of ivy-leaves. Below the neck, the plain edge of a tunic is indicated. Height 31.2. J 19. 42.0.
868. Upper part of male head of soft, white limestone broken obliquely at eyes. The curly front-hair is arranged in three rows of curls. The head wears a conical head-dress, and a wreath of myrtle-leaves. Flat back. Height 17.4. Temples 8.4. Forehead to back 9.8. J 19. 42.0.
869. See No. 767. J 21. 38.0.
870. Fragment of a large terracotta statue, broken off at neck and breast; part of the powerful neck preserved, narrowing upwards. Over left shoulder, a vertical fold of the himation. Large back-hole. Height 29.5. Width 44.0. Front to back 20.4. J 20. 38.5.
871. Terracotta horse, part of a chariot-group; legs and nose missing. Length 11.6. J 20. 38.5.
872. Male head of coarse, brown terracotta, broken off at neck. Nose and beard damaged, and top of head-dress missing. The face has a pointed beard without moustaches; very small, smiling mouth; long nose; eyes without moulded lids. On both sides of the neck, plaits are hanging. The head is crowned by a conical head-dress. Back-hole. Face moulded. Height 24.0. J 20. 39.5.
873. Lower part of large terracotta statue; wheel-made, depressed, cylindrical body. Traces of red paint. Height 50.0. J 20. 40.0.
874. Right foot of a terracotta statue; plain shape, traces of red paint on upper side. The same type as No. 941. Length 21.2. J 20. 40.5.
875. Cock of soft, grey limestone, similar to No. 756, but with shorter legs. No paint. Height 8.1. J 19. 43.5.
876. Statuette of a terracotta archer; head and left arm missing; trunk-shaped body, widening upwards; left arm was outstretched holding the bow; right arm bent over the breast, holding the string. Height 20.5. J 18—19. 38.5.
877. Small, bearded head of yellow terracotta, broken off below chin. Same type, as No. 1059. Height 8.2. J 18. 38.6.

878. Horse's head of grey terracotta, broken off at neck. Long, narrow head; eyes indicated as impressed lozenges. On front of neck, row of tassels. Height 7.6. J 18 38.5.
879. Cart on two wheels of soft, white limestone. The horses are missing. The cart is of the "covered waggon-type" used by the modern Cypriotes, is carefully hollowed out inside and provided with a hooded top. The axle-holder, pierced for the axle, is very thick and clumsy. The wheels are solid, but on the sides, the seven spokes are indicated in red paint. In the cart a man lies prostrate, wrapped up in, and covered by a thick blanket, the surface of which is worked in zigzag-notch technique. His head, arms, and shoulders are visible at the front of the cart, his feet at the back. Right hand was holding the reins. The face is oval with full chin and cheeks, smiling mouth, and conventionalized front-hair. Traces of red paint also on the base of the cart and the blanket. Height 17.5. J 18. 38.0.
880. Plain White VI jug with raised base; oval body with rounded outline; concave neck; plain rim; handle from rim to body. Height 12.3. J 18. 38.0.
881. Bearded statuette of terracotta, evidently a part of a chariot-group; upright body; left arm along the side; right arm put forwards; face carelessly sketched; helmet indicated by band encircling head, and a band running from forehead to back. Part of the rear of the chariot fixed on the back of the statuette. Height 14.2. J 18. 38.0.
882. Archer of terracotta; part of a chariot-group; right arm missing; conical helmet. Lower part, never sculptured. Height 9.4. I 18. 38.0.
883. Male head of light-red, gritty terracotta, well-baked; pink slip. The back of the head with the neck missing. The face is of the same type as No. 668. Height 16.2. Temples 11 45. H 7. 25.0.
- 884-908. Pair of large terracotta feet; rounded, plain shape; very thick ankles. Irregular base-plaque. Height 24.5. Length of feet 29.5. K 18. 42.8
885. Torso of a plank-shaped statuette of soft limestone, broken off at hips and neck; left arm missing; right forearm raised in greeting. Vertically folded chiton; himation hanging over left shoulder, wound across body. Flat back. Height 17.6. Width of shoulders 11.5. K 18 43.7.
886. Female head of greenish-grey terracotta; broken off below neck; lower part of face with part of nose, mouth, and chin damaged and missing. Horizontally wrinkled nose; oval face; wide base of nose; gently modelled eyes and forehead with prominent centre. Hair arranged in melon rolls. Hole through back of hair. Height 14.0. K 18 44.0.
887. Terracotta horse belonging to a chariot-group. Hind legs and tail missing; nose broken off. Very long neck; coarse technique. Height 16.7. K 18. 44.0.
888. Upper part of a bearded statuette in coarse, red terracotta, evidently a part of a chariot-group. Broken across body; left arm and parts of helmet missing. The body is upright. Evidently, the figure is an archer, who holds the bow with the outstretched left arm; right arm bent across the breast holding the arrow. The head is turned vigorously to the left. Thick, powerful neck. Long, rounded beard without moustaches; small mouth; upturned nose and faintly modelled eyes. The hair is visible as an arched roll below the huge helmet, which has a projecting edge and a high ridge, running from front to back. Black painted beard and hair; black eyelids; and traces of black paint on the helmet. Height 24.2. K 18. 44.2.
889. Right forearm belonging to a statue in dark terracotta of more than life-size; thumb and two fingers broken. Fingers are straight. Length 31.8. K 18. 43.8.
890. Male head of soft, white limestone, broken, with a small part of the breast preserved. Face worn. Short, strong neck; oval face looking straight forwards; vertical nose; faintly smiling mouth; elliptical flat eyes without lids. Curled front-hair. On the back the long hair falls down over the neck. The back is flat and vertical. The head wears conical head-dress and a large wreath composed of ivy- and laurel-leaves. Height 21.5. Temples 6.9. Forehead to back 7.8. K 18. 44.0.
891. Male head of gritty, red clay, covered by a red slip. Broken off at neck. Back of head missing; nose chipped. The head has a short beard; smiling mouth; large, protruding eyes without modelled lids. Large, prominent ears. The front-hair is conventionalized. On the back of the head, two plaits fall down behind the ears. The edge of a large helmet crowns the head. The head is made without a mould. Height 10.0. Total width 8.0. K 18. 44.0.
892. Upper part of a male head of soft, white limestone; broken just above the eyes. On the left side, the curly hair falls down over the temple. The front-hair is conventionalized; on the crown, the hair is marked by radiating, incised lines. The head wears a large wreath composed of ivy- and laurel-leaves. Height 9.5. Temples 8.4. Forehead to back 9.2. K 18. 44.2.
893. Much worn torso of a flat, male statue with arms along the sides. Flat back. Limestone. Height 22.0. Breast to back 4.1. K 18. 44.4.
894. Seated, male statuette of soft, white limestone. Head missing. Mediocre workmanship. The statuette sits on a small, rectangular base with left leg bent under the body; right leg is bent, the foot placed on the ground; left arm straight along the side, the hand on the ground; right arm bent, leaning against the knee. The statue is draped in a vertically folded, red-bordered tunic. Height 8.8. Shoulders 6.2. Breast to back 3.8. K 18. 41.0.
- 895-956. Back part of a terracotta rider. The body is hollow and wheel-made. Only the body of the horse with parts of the hind legs preserved; and of the rider upper parts of thighs. The saddle has a fringed edge. Vigorous style. Length 24.3. K 17. 41.5.

896. Votive, male head of hollow terracotta; straight cut below neck; right side of face damaged. Oval face made in a mould; powerful chin; aquiline mouth; long, straight neck; carefully modelled, realistic eyes; faintly wrinkled forehead with prominent centre. Hair parted in the middle and combed backwards. Nape of neck unsculptured. Height 6.2. K 17. 44.2.
897. Female head of brown terracotta made in the same mould, as No. 851. High, conical head-dress. Height 19.5. L 17. 41.5.
898. Terracotta horse; part of a chariot-group. Most of the legs missing. High, upright neck; part of the yoke preserved; nose-band and cheek- and front-bands with blinkers. Front cover painted in black and red. Height 10.7. L 17. 41.5.
899. Large, bearded head of coarse, red terracotta; red throughout (thickness c. 1.2); covered by a thin, red wash on which the paintings are laid directly. Broken off below neck. Surface and paint much worn, especially on the left side. Front piece of the hair roll missing. Edges of top-hole chipped. The shape is similar to No. 960, but the beard shorter and the moustaches more pronounced; four circular knobs decorating each ear on the front side. Thick ribbon around the crown. Traces of black paint here and there on hair, beard, and ear-pendants. Height 132.9. Total width 16.0. Temples 12.8. K 17. 41.5.
900. Terracotta rider; nose, right hind leg, and left foreleg of horse missing. Rider is bearded and fixed on the horse's back without legs. "Snow-man" technique. Height 10.5. K 18. 44.0.
901. Male(?) head of thin, pale terracotta, broken across neck. Right temple and back of head missing. Oval face of classical type; strong chin and cheeks; straight mouth, and nose with sensitive nostrils; eyes with eyelids. Hair parted in the middle and combed back in waves. Wreath of ivy-leaves and fruits in the hair. The face is made in a mould, but carefully worked over. Surface covered by a pink slip. Height 15. 3. Temples 7.5. K 18. 43.0.
902. Bearded terracotta head; life-size; broken off with a part of the breast. Left side of chin chipped. Oval face with small, smiling mouth; short full beard and thin moustaches, faintly modelled eyes. Low conical helmet with arched edge above forehead. Height 48.0. J 21. 39.0.
903. Female head of buff terracotta; made in the same mould as No. 822; broken off at neck. Right side worn. Height 21.3. J 21. 39.5.
904. Part of a male terracotta statuette; broken off at neck and waist. Wheel-made. Upright body with arms along sides. Ends of two plaits below neck. Height 27.5. J 20. 39.5.
905. See No. 759. J 20. 40.0.
906. Lower part of terracotta statue; broken off at knees; sloping feet. Somewhat folded himation with arched edge above the knees. Pieces of back missing. Height 34.0. J 20. 41.0.
907. Lower part of a terracotta statuette; wheel-made and depressed from in front. Straight base; vertical ridge on either side; oblique, fringed fold across body. Height 26.2. Width 30.5. Front to back 16.8. J 20. 41.0.
908. See No. 884. J 19. 40.5.
909. Pair of feet belonging to a terracotta statue of more than life-size. The feet found apart from each other. Naked feet, rather carefully sculptured. The four small toes are missing on both feet because they were not sculptured from the same piece of clay as the rest of the feet. Above the waist, a vertically folded tunic ends. Height 35.5. Length of feet 29.5. K 21. 40.0.
910. Fragment of a terracotta horse; wheel-made; broken off at body and hind legs. Height 15.8. K 21. 40.0.
911. See No. 767. K 21. 41.5.
912. Head of large terracotta horse; hollow; broken off at neck. Ears and mane partly missing. Narrow nose. Traces of a modelled cheek-piece on left side. Length 12.5. K 21. 40.5.
913. Pair of terracotta feet of the same type as No. 949. Length 20.3. K 20. 40.0.
914. Fragment of a sculpture group in soft, grey limestone representing a chariot with four horses. The back of the chariot with the driver, the forelegs, and heads of the horses, missing. The surface is rather worn. The whole group was cut out of one piece of stone with the rectangular base. The horses have slender bodies and long, curved tails. The chariot is sculptured with two solid wheels, which were possibly painted as No. 879. Height 25.0. K 20. 40.0.
915. Female head of brown terracotta; broken off below chin; back of head missing. Rounded face made in a mould with somewhat aquiline mouth; nose partly damaged; eyes realistically sculptured with modelled iris and pupil. Hair is combed back and marked by rough, parallel grooves. On crown, part of a diadem is preserved. Height 13.8. K 20. 42.5.
916. Pair of feet of a terracotta statue of more than life-size; left foot broken at ankle. Part of a vertically folded tunic preserved above the waist. Height 30.0. K 20. 40.0.
- 917-921-931-932-936-957-977.
Four large terracotta horses belonging to a chariot-group. Bodies and hind legs of inner horses missing. Some part restored in gypsum, as is the base on which the horses are now placed. The technique is very rude, and the shapes of the horses extremely clumsy. The necks are short and powerful with short mane; heads rather small with long, thin noses; eyes elliptical with small eyeballs. On the necks of all horses, there are traces of the yoke which on the right, outer horse ends in a hook. The horses seem to have been painted red all over. Actual height including the base 50.0. Height of right outer horse, 42.5. K 20. 40.0.
918. Fragment of female terracotta statuette, broken off at neck and below breast. Upright body; arms somewhat bent along the sides. Height 36.7. Width of shoulders 27.2. K-I. 20. 41.0.

919. Head of large terracotta horse, broken off at neck; hollow; wheel-made. Thick, powerful neck with short, hogged mane; pointed ears; partly broken, long, narrow nose with incised mouth; faintly modelled eyes. Piece of yoke preserved on back of neck. Height 18.4. L 20. 43.5.
920. Lower part of terracotta statuette, made separately from the upper part. Almost cylindrical body; very small feet. Dark terracotta. Height 26.2. Width 16.7. K 19. 44.5
921. See No. 917. L 20. 43.5.
922. See No. 811. K 19 42.5.
923. Lower part of a flat, male statue in soft, white limestone. Small, rectangular base; sloping feet; upright body; right hand holds a bird to the side. Long, vertically folded chiton and himation hanging over both shoulders, leaving the front uncovered. Summary technique. Flat back. Height 41.5. J 21. 39.0.
924. Lower part of flat, male statue in soft, white limestone. Upper part with a piece of right side missing. Left arm bent, the hand holding the forelegs of a buck to the side. Long chiton and himation over left shoulder. Height 67.7. K 20. 39.0.
925. Terracotta head, as No 851 K 20. 40.0.
926. See No. 814. H 7. 22.0.
927. Two terracotta horses belonging to a chariot-group similar to No. 917. The horses are the two left ones of the four. Only the left horse has its head preserved; legs missing. It is provided with front- and cheek-pieces, and nose-band. On the back of the neck, a piece of the yoke is preserved. A wide breast-band ran round all four horses. Length 18.5. K 18. 44.0.
928. Head of terracotta horse, broken off below neck. Long, cylindrical neck with short mane; trace of the yoke behind the head. Small, narrow head with large ears and blinkers; black painted eyes. Incised lines on breast, indicating the breast-band. Height 15.0. J 18. 38.5.
929. Plain White VII jug with flat, raised base; globular body, narrow neck; funnel-shaped mouth with inbent rim. Handle from neck to shoulder. Shape represented by Stroke Polished VII Ware. Height 14.4 J 18. 38.2.
930. Small head of coarse terracotta, broken off at neck; back of head missing. Mouth and eyes marked by incised lines and the curls above forehead by circular incisions. Height 5.7. J 18. 38.5.
931. See No. 917. J 18. 40.8.
932. See No 917 J 18. 40.6.
933. Terracotta horse, part of a chariot-group; legs partly missing. The horse is galloping with neck and head upright. Short mane with fracture of the yoke on neck. Front cover painted in black and red; large, black eyes, red mane and neck-band. Height 11.8. J 17 39.0.
934. Upper part of terracotta statuette, apparently belonging to a chariot with archers. Lower part from the waist, and left arm, which was outstretched, probably with the bow, missing. The body is turned to the left. Right arm bent close to the breast. Large head with a long, full beard; long, straight nose; eyes without moulded lids. The front-hair is carefully curled; on both sides of the neck, long plaits hang down. The archer wears a cap marked by a ribbon around the skull and another straight ribbon from forehead to occiput. Height 24.0. K 17. 39.0.
935. Female head in brick-red, coarse terracotta, covered by a thin red slip. Broken at neck. Diadem chipped; both plaits missing. Full, curved chin; faintly smiling mouth; rather clumsy nose; elliptical eyes with lids and low arched brows. The hair is curled in a low roll round the forehead and falls in two plaits behind the ears. High, pointed, conical head-dress framed by a diadem-like edge at the base. Height 23.3. Total width 9.3. Temples 6.4. K 18. 41.2.
936. See No. 917. K 18. 40.5.
937. Terracotta arm of the same general shape and size as No. 1027. Wheel-made; upper part and four fingers missing. Length 29.5. K 18. 41.5.
938. Fragment of female terracotta statuette; broken off at neck and waist; forearms missing. Upright body with female breasts, faintly marked; arms with short sleeves slightly bent along sides. No back-hole. Height 34.0. Width of shoulder 26.7. K 18. 41.0.
939. Feet of a life-size terracotta statue; trapezoid base; left foot advanced. Narrow, plain shape of shoes, somewhat rounded in front. Length of feet 27.0. K 18. 40.0.
- 940 + 945. Lower part of a life-size statue in dark terracotta; made separately from the upper part; oval section. Long, plain chiton and himation to below the knees. No feet modelled. Height 62.5. K 17. 40.8.
941. Pair of feet on irregular base; left foot somewhat advanced; roughly modelled upper side; rounded outline. Upwards, there is no break, but the edge is roughly finished and out-turned. Probably the feet were not intended for a statue in terracotta, but for a wooden one, which was placed on the feet, thus preserved from dampness and water in the ground. Height 18.9. Width 28.5. Length of feet 23.5. K 17. 41.5.
942. Fragment of a life-size terracotta statue. The part just below the neck preserved. The piece is put together from many fragments, but there are no breaks downwards; the piece was modelled separately with the head, but baked with the lower part of the body. Width of shoulders 51.0. K 17. 42.0.
943. Terracotta horse; part of a chariot-group. The hind legs are fixed on a base of terracotta. Upright neck with short mane; nose-bands and cheek- and front-pieces modelled; front cover painted in black and red; black eyes. Height 12.6. K 17. 42.0.
944. Male head of coarse, crinson clay; smoothed surface; worn. Prominent nose; traces of beard and indistinct ears. Archaic smile. Plain hair with coil of cloth round head. Traces of black paint on hair; hole in top of head. Ringlets on either side of neck broken away. Height 28.0. L 17. 41.0.

945. See No. 940. L 17. 40.5.
946. Hind part of a large, hollow terracotta horse belonging to a chariot-group; cylindrical, wheel-made body. Only right hind thigh preserved. Height 21.0. L 17. 43.0.
947. Male head of soft, white limestone of degenerate, archaic style, broken off at neck. Part of the skull missing; nose worn away. Neck is short and strong; face oval with a somewhat pointed chin. Mouth marked by an incised line, faintly smiling. Elliptical eyes with lids; low forehead; ears visible. The front-hair is arranged in a row of small, spiral curls. On the nape of the neck the hair is short and carelessly curled. The head wears a wreath of ivy- and laurel leaves. Height 12.5. Temples 6.8. Forehead to back 8.1. L 17. 44.0.
948. Flat, male statue of soft, white limestone. Right forearm, left arm, and head missing. Summary technique. Trapezoid base with sloping upper side. Straight, upright body. Arms along the sides, left hand holding a buck by the forelegs. Long, vertically folded, short-sleeved chiton reaching to the ground, and just leaving the feet uncovered. Over left shoulder hangs a himation to below the knees; oblique, incised folds. Flat, unsculptured back. Height 44.5. Breast to back 4.9. K 19. 43.5.
- 949 + 952.
Pair of feet of terracotta, finished upwards in the same way as No. 941. The feet were found apart from each other. Left foot (No. 949) damaged. Height 26.9. Length of right foot 24.8. K 19. 40.8.
950. See No. 761. K 19. 40.8.
951. Lower part of a life-size statue in dark terracotta, preserved only from above the feet; oval section; isolinear feet with shoes; vertically folded chiton reaching the feet. Height 20.0. Width 35.5. K 19. 44.2.
952. See No. 949. K 19. 40.5.
953. Terracotta statuette; broken off at neck and lower part from about the knees. Arms somewhat bent along sides. Almost circular section through lower part. Height 53.0. K 19. 40.5.
954. Fragment of a large, wheel-made terracotta horse; broken off at neck and just behind the forelegs. Type as No. 921. Traces of a red painted front cover. Height 23.2. K 20. 40.6.
955. Female head of coarse, red terracotta; broken at the neck. Pieces of chin and nose, and top of head-dress missing. Oval face with pronounced, pointed chin; small, smiling mouth; prominent, sloping nose; elliptical eyes with lids and high arched brows; small, conventionally sculptured ears. Hair is rolled up in a border above the forehead; behind the ears, the hair falls down in two short plaits. Over the crown is an arched diadem and a high, conical head-dress. Traces of black paint on the hair. The head is built up by hand, without the potter's wheel, in spirally wound layers of clay. The face is probably moulded, but carelessly worked over. Height 26.2. Total width 12.9. Temples 8.6. K 19. 42.5.
956. The forelegs of the terracotta rider No. 895. L 19. 42.5.
957. See No. 917. L 20. 41.5.
958. Male head of very soft, yellow terracotta, broken below neck. Oval face; pointed chin; small, smiling mouth; thin nose (slightly damaged); eyes with lids in shape of myrtle-leaves; carelessly sculptured ears. Fragments of an ivy wreath in the hair. The face is hand-made. Height 25.0. L 19—20. 40.5.
959. Left foot of a terracotta statue; very much sloping upper side; somewhat pointed in front. Height 16.0. Length 18.0. L 20. 41.0.
960. Large, male head of red, rather coarse and sandy terracotta (thickness c. 1.3) with black inside; covered by a thin, red wash on which the black paint is directly applied. Front-leaves of the wreath missing and most of the others chipped; right plait of hair missing. The head has a large, flat beard with rounded edge, thin, downwards curved moustaches; very small, smiling mouth; straight, slightly upturned nose; long almond-shaped eyes, which protrude somewhat from the cheeks, but with no modelled details; thin, curved eyebrows; large, black painted iris; small, summarily modelled ears; comparatively low, straight forehead. The hair is rolled up over forehead and temples, framing the upper part of the head. On the crown is a wreath composed of ivy-leaves held together by two ribbons. Behind the ears, the hair falls down in two massive, triangularly projecting plaits, reaching to the shoulder. The head is built up by hand without potter's wheel; is hollow and has a large, circular hole at the top. The face was moulded, but carefully worked over by hand. Beard, hair, ears, and wreath are entirely hand-made. Black painted hair, beard, and moustaches, eyebrows, eyelids, and iris. Height 31.7. Total width 19.0. Temples 13.1. L 19. 40.5.
961. Lower part of flat, straight statue of soft, white limestone. Right foot with part of the base missing. Broken from the breast. Very small base with sloping upper side; upright legs and body. Vertically folded chiton reaching to the feet; long, obliquely folded himation. Folds indicated with incised grooves. Flat back. Height 50.5. Abdomen to back. 6.5. L 19. 43.5.
- 962 + 1006.
Pair of legs of a terracotta statue of more than life-size; broken off below knees; feet missing. The legs are wheel-made and on this core the boots are sculptured in a vigorous technique; they reach half-way up to the knees; in front, the upper edge is arched and upstanding. Boots painted red and tied over the ankle. Height 35.0. Length of foot, No. 1006, 34.0. L 19. 43.8.
963. Fragment of a large, female terracotta statue; broken off at neck and below breast; left shoulder missing. Right forearm raised in greeting. Chiton with edge visible around neck; the vertical folds indicated by thin grooves. Over left shoulder hangs a himation with the edge, obliquely across the body. Height 42.5. Shoulders 40.5. L 19. 41.0.
964. Female head of dark-red terracotta, broken off below

- neck; lower part of face with chin and mouth worn away. Face made in a mould; of the same type as No. 813. High, conical cap. Hair painted black. Height 24.0 L 17. In No. 945.
965. Fragment of shallow terracotta lamp; round base; out-turned rim. Pinched nozzle missing. Length 9.0 L 17. In No. 945.
966. Part of a wheel-made body of a terracotta statuette, upper part from breast missing. Upright body; somewhat depressed from in front. Long, plain tunic leaving the feet uncovered. Vertical joint of tunic along left side. Height 40.0. Width 16.4 K 19. 44.0
967. Part of terracotta statuette, as No. 1056, but with fore-arms somewhat more raised; broken off at breast and lower part. Height 34.5. K 19. 43.0.
968. Terracotta horse, carrying a double sack on its back. Left fore-leg missing; nose broken. On both sides, the bottom of the sack is pierced. "Snow-man" technique. Height 12.5. K 19. 33.0.
969. Breast part of a flat, male statue of soft, white limestone. Broken off at the shoulders and waist. Right arm missing. Vertically folded himation over left shoulder, wound around the body. The folds are indicated by means of incised grooves. Flat back. Height 24.0. Breast to back 9.0. G 10. 4.0.
970. Male head of hard, grey limestone, broken off at the chin. Surface worn. Rounded, fat face (nose damaged); deeply set eyes with elliptical eyelids; curved forehead. Short hair, very roughly marked. Height 12.0 G 11. 4.0.
971. Fragment of a covered terracotta lamp with moulded lid; small, vertical handle on lid, circular nozzle. On lid, a representation of a love scene. Length c 7.5. G 11 4.5.
972. Roughly sculptured male head of hard, grey, coarse limestone. The technique resembles that of Nos. 808 and 974, but the specimen is not so well preserved. The head is obliquely broken through the neck, which is very thick. Full chin and cheeks; deeply set eyes, probably without any marked lids, but with prominent balls; short, wide nose, broken; gently curved forehead. Ears are roughly marked and seem very pointed, as for a satyr. The hair is only roughly marked, on the front by means of a curved, incised line. The temples are covered by similar patches of hair. On the back of the head, there is a large, vertical fracture, which possibly indicates that the head was a part of a relief (cf. Nos. 808 and 974). Height 13.5. Temples 7.6. Level 3 30. I 7 17.0.
973. Female head of coarse, darkened terracotta covered by a red slip on which the black paint is applied. Broken off at neck. The back of the head and the buttons of the necklace, missing. Left part of head-dress chipped. Thick neck; small, pointed chin, straight mouth with a very faint smile, long, straight nose; elliptical eyes with lids and thick, low brows. Rich, curly hair crowned by a diadem with applied rosette-ornaments. Around the neck, a necklace. Black hair, iris, eyelids, and eyebrows. The head is entirely hand-made; face is modelled. Height 16.5. Total width 12.0. Temples 8.9. I 7. 17.0.
974. Male head of hard, coarse limestone. The vigorous style of the head resembles that of No. 808. The neck, through which the fracture runs obliquely, is very thick, with strong neck muscles marked on left side. Though with a general, oval outline, the face is full, with very strong and prominent chin. The lips protrude, the corners of the mouth being marked by means of small angles. Prominent, strong nose with marked nostrils. Half-moon shaped eyes with prominent, arched upper lids. The low forehead is vigorously sculptured with large, protruding arches above the eyes, which give the head its characteristic expression. Large, carelessly sculptured ears. Short hair, the curls being only roughly marked. The head seems to have been a part of a relief, as the occiput ends with a broken-off projection. Height 15.0. Temples 8.0. H 9. 23.0.
975. See No. 759. K 19 40.2.
976. Large, female head of coarse red, terracotta (thickness 1.3). Well baked and covered by a thin, red wash on which the black paint is applied. Broken off below neck. Intact except for the hair-roll which is chipped just above the forehead. Oval face with pointed chin and a small dimple at the centre; very small, smiling mouth, straight nose. The eyes are faintly prominent from the cheeks; curved, low eyebrows; straight, low forehead and small, conventionalized ears. Hair rolled up above forehead, framing the upper part of the face. Thick ribbon around the crown. The long hair falls in two plaits behind the ears reaching to the shoulders. — The head is built up by hand, without potter's wheel, but by means of spirally wound bands or layers of clay, leaving a wide, circular hole on the crown. Face is moulded, but carefully worked over. Height 30.2. Total width 15.8. Temples 12.0. L 19. 40.5.
977. See No. 917. L 19. 40.5.
978. Left foot of a life-size terracotta statue; broken off above the ankle; toes missing. The foot is naked. Carefully sculptured and painted red. Actual length 20.8. L 19. 40.8.
979. See No. 814. L 17. 38.0.
980. Head of large terracotta horse; broken off through neck; nose missing. Circular, hollow neck; faintly modelled eyes; short mane; pointed ears; blinkers fixed by thin bands; cheek bands. Height 16.0. J 18. 38.0.
981. Female head of buff clay; broken off below chin; left side of face, and back of head missing. Face made in a mould of the same type as No. 813. Curly, conventionalized front-hair. Probably the head had a conical cap. Height 14.5. K 17. 37.0.
982. Upper part of a large, bearded statue of reddish terracotta. Lower part from about the elbows missing. The following parts are restored: left side where the left arm should be marked in some way, pieces of lower part of abdomen, large parts of the back on left side,

- right side of the head with the temple, and part of right eye and wreath in hair. The base of the actual statue is not the original base of the upper half of the statue but an edge made when mending it. The position of left arm could not be ascertained; right arm bent up to the breast, the hand probably holding some object; fingers partly missing. Breast very powerful; straight neck; oval face with large, curly, full beard which extends from the ears to the top of the chin, but leaves the mouth clear. The ends are made in a rare technique: small balls of clay have been flattened against cheeks and chin, and afterwards given a circular impression made by means of a thin pipe; from the upper lip plain moustaches; the nose, partly broken off, is prominent. Large leaf-shaped eyes with convex eye-balls and sculptured lids; well marked eyebrows. Above the forehead, the hair is arranged in small, vertical screw-curls, visible below a wreath composed of flowers and ivy-leaves. On either side of neck, two plaits hang down extending over the breast. The man wears a himation hanging over both shoulders, but leaving the right side of breast uncovered. Height 75.0. Shoulders 61.5. Temples c. 15.0. K 19. 40.5.
983. Nude, male statuette of soft, white limestone. Left leg from knee, right foot, left arm, but not the hand, and head missing. Right leg is slightly advanced; body upright and slightly bent to the side. Right arm hangs along the side, partly sculptured free from the body; left arm is bent at the elbow, the hand holds an offering of fruits pressed against the body. The body is carefully sculptured all round, and reveals a perfect, anatomical knowledge. Height 37.4. Shoulders 12.8. Waist 6.5. Pelvis 8.5. K—L 17. 39.0.
984. Terracotta horse; nose and legs partly missing; part of a chariot group. Upright, tall neck with part of the yoke just behind the head. Height 15.0. K 17. 39.5.
985. Fragment of a terracotta chariot; similar to No. 986, but with wheels preserved. Red and black painted spokes. Upper part of archer painted red. Height 13.5. K 17. 39.5.
986. Fragment of a terracotta chariot; part of a group with horses. The chariot is divided into two compartments, one for the driver, who is broken off, and one for the archer, partly preserved. Looped rear. Height 11.0. K 17. 39.5.
987. Right hand holding a bowl; fragment of a statue in soft, grey limestone. The hand broken above the wrist holds the bowl from below, with the thumb on the edge. The bowl is hemispherical and is represented as filled with a red painted fluid up to the edge. At the joint between the bowl and the hand, there is a projection broken at the end. It certainly connected the bowl with the statue and acted as a support. Length 11.3. K 17. 39.0.
988. Male head of red, gritty terracotta, well baked and covered with a thick yellowish-white slip on which the dark paintings are applied. Broken below the neck.
- The whole back of the head missing; wreath and front-hair slightly damaged. The neck is extraordinarily thick; face oval with full chin and cheeks, small smiling mouth; clumsy nose and low forehead. The eyes are carelessly worked. The hair is curled in a row around the forehead. An ivy-leaf wreath crowns the head. Probably the head-dress was conical. Traces of black paint on the hair and some of the ivy-leaves. The head is hand-made with the exception of the face which is moulded. Height 16.5. Temples 6.0. I 7. 17.0.
989. Female head of pale, coarse terracotta of a very soft character, broken off below neck. Neck straight and comparatively long. Face is oval with full cheeks; faintly smiling mouth; straight nose; eyes faintly modelled without lids; large, protruding ears. Front-hair carelessly conventionalized. The skull is comparatively high and decorated with a leaf-diadem. Traces of black paint on the hair. The face is made in a mould, but carefully worked over. Surface covered by a thick, yellow slip. Height 26.5. L 19. 40.5.
990. Bearded head of brown terracotta; broken below neck with a part of the breast; right temple slightly worn. Oval face made in a mould; flat, somewhat pointed beard extending from the ears; curved, thin moustaches; very small, smiling mouth; thin, straight nose; faintly modelled eyes; concave ears; plaits on either side of neck. Wreath of laurel-leaves in hair. Circular hole on top of head. Height 36.0. L 19. 40.5.
991. Fragment of the side and shoulder of a large terracotta statue. Body wheel-made; depressed from in front. Length 54.0. L 19. 40.5.
992. The base of a large terracotta chariot, making part of a group with horses, some hind legs of which remain on the piece. It consists of a thick, hollow cylinder standing on a base-plaque. On this cylinder, the chariot was fixed, while the axle was fixed on the sides of the cylinder. Height 20.3. L 19—20. 39.5.
993. Small chariot group of terracotta; four horses with a very diminutive chariot with wheels. The driver stands to the right (head missing). Beside him is a warrior in a helmet with cheek pieces. The horses are driven with two reins running between the outer and inner horses. Right and left horses are held together by means of two yokes with upturned ends. The outer horses have breast-bands rather high up on the neck. Very rude "snow-man" technique. Length 11.2. Height 10.5. L 17. 38.0.
994. Body of terracotta horse. Length 9.0. L 17. 39.0.
995. Four small terracotta horses belonging to a chariot-group. All the heads missing. Parts of the reins visible on the backs. Height 5.3. L 17. 39.5.
996. Terracotta chariot; fragment of a group with horses; rude technique; small wheels. In the chariot, were a driver and two warriors, the lower parts of which are preserved. Height 11.2. L 16. 39.5.
997. Chariot group of dark terracotta; irregular base-plaque. Comparatively small chariot with two solid wheels;

- the driver has a turban; the two warriors conical helmets: the one to the left is an archer. The poles of the chariot rests on the two yokes, which hold the right and left horses together. Rude "snow-man" technique. Traces of black paint on horses and base. Length 15.2. Height 15.5. L 16. 38.5.
998. Terracotta chariot belonging to a group with horses; wheels are missing; right side of chariot damaged. The chariot is divided into two compartments, one to the right for the driver who holds the reins in his outstretched arms, with the reins wound across the shoulders; the other for an archer whose left arm with the bow is missing. "Snow-man" technique. Height 16.5. L 16. 37.5.
999. Bearded terracotta head carelessly modelled in snow-man technique. Height 3.5. L 18. 40.3.
1000. Terracotta horse belonging to a chariot group; left fore-leg missing; "snow-man" technique. Front- and cheek bands and nose-band; blinkers; part of the yoke visible on back of neck. Horse painted red; transverse lines on reins. Height 14.3. L 18. 40.0.
- 1001 + 1018. Bearded statuette of terracotta, evidently the driver belonging to a chariot with warriors. The head (No. 1001) was found separately from the body (No. 1018). Trunk-shaped body, widening upwards, and made on a potter's wheel; breast somewhat flattened. Both arms uplifted (hands missing) for holding the reins. Head looking straight forwards; long beard; no moustaches; smiling mouth; thick, prominent nose; painted eyes in shape of myrtle-leaves. High, conical helmet with buttons on either side. Black painted beard, eyebrows, and edge of helmet. Height 30.9. L 18. 39.5.
1002. Terracotta horse from the same group as No. 984. Legs partly missing. Height 13.0. M 18. 41.0.
1003. Fragment of flat, male statue of soft, white limestone. Left foot, upper part from the breast, and a piece of right side missing. The body is upright; left knee slightly bent; feet are sloping. Left hand held a buck, the legs of which are visible along the side. The statue wears a vertically folded chiton reaching the ground, and an obliquely folded himation, the folds being indicated by means of incised grooves. Summary technique. Flat, unsculptured back. Height 43.5. M 18. 40.5.
1004. Terracotta horse made in "snow-man" technique. Right ear broken. Height 10.5. L 18. 40.0.
1005. Fragment of a flat, male statue of soft, white limestone. Only the part from about the knees up to the breast preserved; upper part worn. Upright, flat body. Vertically folded chiton and obliquely folded himation hanging from left shoulder. Summary technique. Flat back. Height 40.0. Abdomen to back 5.2. L 18. 41.0.
1006. See No. 962. L—M 15. 40.0.
1007. Flat, male statue of soft, white limestone. Head missing. Small, irregular base with sloping upper side; straight upright body, both arms along the sides, right hand holding a round fruit, left hand holding a small bird at the wings. Long, short-sleeved, vertically folded chiton reaching to the feet. An obliquely folded himation is wound around the body, one end hanging over left shoulder. The folds are indicated by means of incised grooves. Flat back. Height 48.0. M 18. 39.6.
1008. Fragment of a straight, flat statue of soft, white limestone, broken at both ends. Folded himation. Flat back. Height 16.0. Width 10.2. Thickness 3.1. M 18. 40.5.
1009. Upper part of a life-size, male terracotta statue; forearms and head missing; pieces of the breast on right and left side and the back, restored. Upright body with wide shoulders; forearms bent forwards. Short-sleeved chiton obliquely folded; himation over left shoulder wound obliquely across the body. The upper edge of the himation is shaped like twisted rope. Small back-hole. Height 70.5. Width of shoulders 49.0. Breast to back 23.7. M—N 18. 41.0.
1010. Lower part of a male terracotta statue; small, irregular base. Left foot somewhat advanced; upright legs and body. The man wears pointed shoes, evidently of soft leather, carefully tied at the front of the ankle. The legs are very thick. Short tunic to about the knees with a rounded piece hanging down in front as on the statue No. 1728 + 1740 from Ajia Irini. This piece is, however, broken off. The tunic is made of two pieces with joints along the sides. Height 56.5. Width 27.0. Front to back 19.5. N 18. 41.0.
1011. Upper part of a female terracotta statuette, as No. 806, and 815; broken off obliquely at breast. Surface of face is badly worn. Height 35.5. N 18. 41.0.
1012. Bearded head of dark terracotta; broken off below neck; moulded face covered by a brown slip on which eyes and beard are painted. Oval face with short full beard; small, smiling mouth; straight nose; faintly indicated eyes without modelled lids. Plaits hang down on either side of neck. The head is crowned by a conical head-dress, possibly a leather helmet, the base of which is provided with a radiate crown, consisting of triangular rays arranged in two lines and with buttons between front rays. Height 43.0. N 18. 41.0.
- 1013 + 1051. Flat, male statue of soft, yellow limestone. Feet and right hand missing; face entirely worn away. Left leg slightly advanced; straight legs and body. Right arm along the side; left arm slightly bent along the side; the hand holding a bird by wings. Round face with conventionalized front-hair; on the back of the head, the short hair is indicated by incised lines making a net-work pattern. Wreath of laurel-leaves in the hair. Vertically folded chiton with sleeves to the elbows. The chiton reaches to the feet. From left shoulder hangs a himation with soft, oblique folds. Flat back. Height 59.5. Shoulders 15.7. Breast to back 6.5. N 18. 41.0.

1014. See No. 768 N 17. 40.5.
1015. Male head of soft, white limestone, broken off below chin. Only the front part of the head is preserved. The back of it is broken. Forehead and nose damaged. The chin is carefully worked; the mouth faintly smiling; eyes are elliptical with lids marked by sharp ridges. The front-hair is arranged in small, spiral curls; over the crown, the hair was apparently marked by radiating, incised lines. The head wears a large wreath of ivy-leaves with some berries just over the forehead. Height 16.6. Temples 8.6. M 17. 43.5.
1016. Terracotta horse; part of a chariot-group; nose and right foreleg damaged; tail along left hind leg; short body; high, upright neck with piece of the yoke. Height 10.8. M 17. 44.0
1017. See No. 741. M 17. 42.5.
1018. See No. 1001. M 18. 38.5.
1019. Terracotta horse, made in a rude "snow-man" technique; right foreleg missing; part of a chariot-group. Short body; long, curved neck; large head; trace of the yoke on neck. Height 13.9. M 18. 38.5.
1020. See No. 703. M 17. 38.5.
1021. Stone head. See No. 741. Height 10.0. L 17. 38.5.
1022. Male head of soft, white limestone, broken below neck. Nose damaged; right side and lower part of face much worn. Neck is strong and short; face of triangular shape. Mouth is faintly smiling. Eyes with lids in shape of myrtle-leaves. The hair is short and curly all over the head, the front-hair hanging over the forehead with small, spiral curls. The head wears a large wreath composed of ivy- and laurel-leaves with a row of berries in the middle. Height 16.8. Temples 7.7. Forehead to back 11.3. L 17. 39.0.
1023. Lower part of a flat statue in soft, white limestone. Surface worn. Small, rectangular base with sloping feet. The details of the long chiton are worn away. Flat back. Height 16.2. L 17. 39.0.
1024. Female(?) head of soft, white limestone, broken off below chin. Rounded face with full chin and cheeks; thin lips; almost vertical brow- and nose-line; eyes without lids, carelessly worked. Conventionalized front-hair. The head wears a conical cap, the top of which is missing, and a wreath of myrtle-leaves. Flat, unsculptured back. Height 8.7. Forehead to back 2.8. L 17. 39.8.
1025. Driver of terracotta belonging to a chariot-group; head missing. Cylindrical, wheel-made body with arms raised (partly missing). Traces of red paint on body. Height 19.8. M 17. 42.0.
1026. Male head of soft, white limestone, broken below neck. Head looking straight forwards. Neck is short and strong. Face oval and regular with mouth marked by a deep line; straight, broad nose; elliptical eyes with faint lids. The hair is short and curled in a peculiar way. Over the whole skull, the curls are arranged in careful spirals resembling certain kinds of snail-shells. Surface is somewhat worn, but the features of the head are clearly distinguishable. Height 13.0. Temples 7.9. Forehead to back 10.8. M 17. 43.0.
1027. Left forearm of terracotta statue, almost life-size; made separately from the body and fixed to it by means of a peg pushed into holes on the upper part of the arm. The arm is bobbin-shaped; fingers straight, close together. Length 31.4. M 16. 41.0.
1028. Female head of brown terracotta, broken off below chin; left side, nose, and back missing. Rounded face made in a mould; archaic smile; faintly modelled eyes with low forehead. The front-hair was originally conventionalized according to the mould. Subsequently, however, a row of small, hanging, spiral curls have been added above the first hair; plain crown conical head-dress, partly missing. Height 16.4. M 17. 39.5.
1029. Relief-plaque of red terracotta; lower part missing. The representation consists of a woman seated on a throne with strictly frontal position. She wears a long garment and a conical head-dress. At the left side, a smaller figure is seated on her knee, holding left hand on the woman's left breast. Both heads are turned outwards. All details are very faint. May be a representation of Isis with Horus. Height 10.7. M 16. 40.0.
1030. Male head of soft, white limestone, broken off below the neck. Short, powerful neck; oval face, carefully sculptured with slightly prominent, aquiline mouth; long, almost vertical nose; large eyes without lids. Conventionalized front-hair. The hair on the back of the head is marked by incised lines forming a net pattern. Wreath composed of laurel-leaves and hanging fruits in the hair (cf. No. 633). Height 12.5. Temples 7.3. M 17. 43.0.
- 1031 + 1072. Upper part of a flat, male statue in soft, white limestone, broken obliquely at the waist. Upright body (No. 1072) with head looking forwards; arms along the sides. Face (No. 1031) is oval with full cheeks; the archaic smile has entirely disappeared; almost vertical nose (tip missing); eyes without lids, carelessly worked. Front-hair conventionalized; short hair on the back of the head marked by zigzag notches. In the hair, a wreath composed of laurel-leaves and some vertically hanging fruits. The statue is draped in a vertically folded chiton. Over left shoulder and arm hangs a himation, which is twisted over the abdomen. Flat, unsculptured back. Height 31.0. Shoulders 14.5. M 17. 43.0.
1032. Fragments of right foot in dark-red terracotta; broken off at the ankle, so that only forepart of the foot is preserved. The execution of the very heavy boot is remarkable: around the sides, are circular loops applied in relief, and in front a large loop runs up over the toes. The loops most likely indicate lobnails of the same kind as is used in our days on the peasant's boots. Length 17.5. N 18. 40.5.

1033. Lower part (feet with base) of a statue in soft, white limestone, broken off just above the feet, which wear red painted shoes. Base sq. 13.5 17.0. M 17. 43.5.
1034. See No. 811. N. 17. 43.5.
1035. Male head of hard, grey limestone, broken below the short neck. Oval face; handsome-looking with rounded chin; straight mouth with curved overlip. Straight, vertical nose with broad base. The eyes are fairly deeply set, and distinctly sculptured with well marked, arched upper lids, and almost straight lower lids. The hair is carefully worked with small, pointed curls, sometimes developing to free, longer curls. Height 16.4. Temples 9.2. Forehead to back 11.9. K 8. 21.5.
1036. Female head of terracotta; broken off below chin; back of head missing; surface rather worn. Oval face; pointed chin; straight mouth; eyes with lids; hair parted in the middle and combed back; face moulded. Height 12.4. Stray find
1037. Fragment of a hard, grey limestone provided with an inscription. See Appendix III. Inscribed face 6.6 12.2.
1038. Torso of female terracotta statuette, made in a mould and subsequently worked over with a pointed instrument; broken off at the hips and through neck; arms missing. Long tunic girdle over abdomen. Height 16.5. F 7 19.5
1039. See No. 616. I 6. 23.0
- 1040 - 1042. Male statue of hard, grey limestone. Right forearm and head missing. Surface rather corroded. Rectangular base with horizontal upper side. Large, naked feet. The figure rests on his left leg with the right leg slightly bent; upright body. Right arm slightly bent along the side and partly sculptured free from body; left forearm raised, the hand holding the end of the himation which hangs from left shoulder. The figure is draped in a himation which leaves right side of the breast and shoulder bare. Flat back. Height 150.0. G 7 35.0
1041. Male statue of sandy limestone. Head missing. Chipped and worn all over. Comparatively nicely worked and richly folded himation. Height 98.0. I 5 25.0.
1042. See No. 1040. I 5. 20.8
1043. See No. 669. J 5-6 20.5
1044. Male statue of hard, white limestone, head and feet missing; both hands damaged. The figure rests on right leg, with left leg slightly bent; upright body, slightly turned right. Left forearm raised; hand holding the end of the himation, hanging down from left shoulder. Right hand holding the horizontal folds of the himation running across the abdomen. Breast, and right shoulder with arm, bare. Around the body is wound a himation reaching to below the knees. The end of the himation hangs down from left shoulder along the side, held by left hand. Flat, unsculptured back. Height 43.5. Shoulders 19.0. Breast to back 7.0. J 6 20.0.
1045. Male statue of hard, grey limestone; feet and head missing. The same position, as No. 610, but sculptured in a very summary technique. Right arm along the side, the hand holding some round object. The neck fracture is notched and provided with a square hole in the centre intended for a peg to fix the head. Height 39.0. Abdomen to back 10.5. I 4 22.0.
1046. Head of terracotta horse, broken off through neck. Long, narrow nose, deep nostrils, eyes shaped like small button; mane ends in a point. The head is equipped with nose-band and front- and cheek-pieces fixed together by means of small studs; small, out-turned blinkers. Traces of red paint on mane and blinkers. Length 13.0. J 5. 25.5.
- 1047-1049. Male statue of grey, hard limestone; more than life-size. Right forearm and head missing; left leg damaged. Rectangular base; left foot advanced; the legs are not sculptured free from background; right arm free from body along the side; left arm bent, the hand holding the folds of a himation which hangs over left shoulder and across the body; bare feet. Flat back. Height 165.0. K 7-8. 24.0.
1048. Head of terracotta horse; broken off below the long neck. Carelessly sculptured head with narrow, tapering nose; short mane. Nose- and front-band; blinkers. Trace of the yoke broken off at back of neck. Height 14.6. J 7. 20.5.
1049. See No. 1047. J 7-K 8. 19.5.
1050. Male head of hard limestone, broken at neck. The face is entirely missing. Short, roughly sculptured hair. Height 13.5. K 7. 19.5.
1051. See No. 1013. K 8 22.5
1052. Male head of soft, white limestone, broken obliquely at neck. Piece of chin missing; left side of face worn. Face is oval with a very faint, archaic smile. Chin and cheeks softly worked; the nose was slightly prominent; eyes in shape of myrtle-leaves without lids. Ears roughly marked. Over the forehead, the hair is horizontally curled. On the back of the head, the half-long hair hangs down in carelessly designed curls. Over the crown, the hair is marked by radiating lines. Height 10.8. Temples 5.7. Forehead to back 7.5. K 9. 22.5.
1053. Male head of soft, white limestone, broken off below neck. Oval face with prominent chin and vertical front-hair. The short hair on the back of the head is zigzag-notched. Wreath of laurel-leaves in the hair. Height 13.5. Temples 6.1. Forehead to back 4.8. M 17. Surface.
1054. Part of female statuette of terracotta; feet, left hand, and head missing. Trunk-shaped body made on a potter's wheel and carelessly worked over; female breasts, faintly marked; right arm along the side; left arm bent over the breast. Long, plain tunic with short sleeves and a vertical fold on either side. Height 49.0. H 22. 28.5.

1055. Female head in yellow terracotta; of the same type as No. 813; broken below neck. Height 21.5. H 22. 29.6.
1056. Part of a male statuette in dark terracotta; broken off below neck and obliquely through lower part of body; right forearm missing. Circular section through body, somewhat depressed over the breast; arms slightly bent along sides. Height 34.8. Width of shoulders 18.0. H 22. 28.0.
1057. Female(?) head of yellow terracotta, broken off at neck; right side badly worn. Oval face with pointed chin; thin, straight mouth; rather upturned nose; eyes very faintly modelled. Head-dress much destroyed. Circular hole on the top of the head. Height 12.4. H 22. 28.5.
1058. Torso of a flat, male statuette in soft, white limestone. Broken through the thighs; head missing. The body is upright; arms kept along the sides. Right hand holds a disc-shaped object. The object held by the other hand cannot clearly be distinguished. Possibly it is a small jar. The statue wears a short-sleeved chiton vertically folded. Over left shoulder hangs an obliquely folded himation, which has traces of red paint. Flat back. Height 14.4. Shoulders 7.8. Breast to back 2.9. G 22. 24.0.
1059. Small, bearded head of red terracotta; powerful neck; oval face; long, pointed beard; no moustaches; smiling mouth; straight nose; eyes without lids, in shape of myrtle-leaves; conventionalized front-hair; hanging plaits on sides of neck. Height 8.5. G 22. 24.0.
- 1060—1061. Fragment of a flat, male statue in soft, white limestone. Feet and upper part from breast missing; left hand damaged; left leg slightly advanced; upright body. Arms slightly bent along the sides; right hand holding a round object. Left hand held a bird, now partly damaged, close to the side. The statue wears a long chiton with vertical folds, indicated by means of incised grooves. The chiton is held together by a belt, or girdle with overlapping, hanging ends. Over both shoulders hangs a vertically folded himation, on left side reaching to below the hip, on right side to below the knees, where the surface and all details are worn away. The himation leaves only the front part of the body uncovered. Height 63.0. Total width 25.7. Breast to back 9.0. G 21. 25.3.
1061. See No. 1060. G 21. 24.0.
1062. Flat, male statue of soft, white limestone. Feet, right forearm with piece of the right side, missing. Parts of breast and abdomen damaged. Upright legs and body; arms along the sides; left hand holding a rounded, partly damaged object. The shoulders are very sloping. Long neck, oval face carefully sculptured; faintly smiling mouth; eyes with lids in shape of myrtle-leaves. Front-hair arranged in a row of small, spiral curls; the short hair on the back of the head is also conventionalized. Wreath composed of laurel leaves and hanging fruits. Vertically folded chiton with sleeves to the elbows. The himation hangs over left shoulder, and is wound around hips and legs. The folds of the chiton are wide and soft. On the chiton, there are also some irregular, horizontal grooves. The folds of the himation are carefully arranged, softly curved across the legs, and radiating from a point near the left hand. Flat back. Height 70.0. Shoulders 22.0. Breast to back 8.0. G 23. 24.0.
1063. Bearded head of dark, red terracotta; broken off below neck; back of head missing. Part of left side restored. Oval face with short full beard and hanging moustaches; puffy cheeks; small, elliptical eyes, and wrinkled forehead. Hair is curled in rough, spiral curls. Probably there was a ribbon, or a wreath in the hair. Height 23.0. G 23. 33.5.
1064. Female head of yellow or buff terracotta; broken off below neck. Small, rounded face made in a mould; prominent chin; mouth with archaic smile; prominent nose; eyes in shape of myrtle-leaves marked by means of short, incised lines; plaits on either side of neck. Conical head-dress with upturned edge. Height 21.8. H 22. 22.0.
1065. Male statue of hard, grey limestone. Right foot, head missing. The same attitude, as No. 609. The surface is very much corroded and hollowed by numerous, small cavities. Flattened, unsculptured back. Height 41.5. I 5. 16.5.
1066. Female statue of hard, grey limestone; left hand and head missing; surface very much corroded. The statue rests on a small, rectangular base with sloping upper side; right leg slightly bent; upright body; left forearm is raised; the hand probable held some object; right forearm raised in greeting; the fingers are missing. Long chiton; himation hanging over left shoulder and wound around the body outside the arms. Flat, unsculptured back. Height 60.0. J 5. 13.5.
1067. Statue of a small boy in hard, grey limestone. Head missing. The technique is very rude. Irregular base. The legs are very thick, slightly bent, and apart from each other. The child is dressed in a short-sleeved tunic, which he lifts up just enough, to show the male organ. The legs are not sculptured free from the background. Roughly worked back. Height 48.5. J 4—5. 13.0.
1068. Nude, male statue of grey, hard limestone. Feet, part of left leg, left hand, and head missing. Pieces of left shoulder and right upper arm damaged. The statue rests on right leg, with left leg slightly bent back; upright body with fat, rather prominent abdomen. Left arm is bent close to the side; the hand was holding a bird, the tail of which only now is preserved. Right arm is also bent and sculptured nearly free from body. The statue wears a long, vertically folded himation hanging over both shoulders on the back. It is fastened over the breast by means of a knot. Along the edge of the himation around the neck, there is a

- row of small, square depressions, which probably were once inlaid with some other material. The whole statue is sculptured in a technique which makes everything rounded. The body is three-dimensional, distinctly different to the flat, archaic sculptures. Height 45.5. Shoulders 22.0. Breast to back 11.5. I 4. 13.0.
1069. Nude, male torso of hard, yellow limestone, probably representing Apollo. Legs from above the knees, arms, and head missing. Surface much worn. Left leg advanced; upright body. Right arm was partly sculptured free from body; it was held along the side; left arm was also sculptured free from the body. On the left thigh, parts of a lyre are preserved, which was held by left hand. Apollo wears a shawl over both shoulders hanging down on the sides. On the back, the lower part is sculptured, but the upper part only flattened. Height 32.5. Shoulders 20.6. Breast to back 8.4. J 5. 24.5.
1070. Fragment of nude, male statue probably representing Apollo; soft limestone; more than life-size; broken off across shoulders and below breast. The muscles carefully sculptured in archaic technique. Height 40.0. Width of shoulders, about 70.0. O 18—19. 40.0.
1071. Lower part of a flat, male statue of soft, white limestone. Trapezoid base with sloping upper side. Upright body. Long, vertically folded chiton reaching the ground. From left shoulder hangs a himation to about the knees with oblique folds, indicated by means of incised grooves. Flat back. Height 40.0. N 17. 38.0.
1072. See No. 1031. N 17. 38.0.
1073. Upper part of a male statue in soft limestone; head missing, as No. 1070. Height 37.0. J 25. Surface.
- 1074—1094.
Flat, male statue of soft, white limestone. Feet and right arm missing; surface worn, especially on the lower parts. The head (No. 1094) was found apart from the body (No. 1074). Right foot slightly advanced; upright body; arms along the sides, slightly bent, left hand holding a bird, somewhat damaged at the wings. Short neck, large chin, oval face with faintly smiling mouth; deeply sculptured eyes with elliptical lids; almost vertical, straight front- and nose-line; front-hair conventionalized. Laurel wreath in hair. Long, vertically folded chiton. Over left shoulder hangs a himation, wound around the body. Flat back. Height 84.5. J 25. Surface.
1075. Torso of a draped, male statue of more than life-size. Hard limestone. Height 79.5. N 23. Surface.
1076. Bearded head of red terracotta, broken off below chin; back of head missing. Both temples restored. Rounded face with a sharp-edged, full beard and thin, modelled moustaches; powerful cheeks; small eyes with elliptical lids; iris indicated with an incised circle. Height 19.3. I 24. 20.0.
1077. Small statuette of red terracotta, made in a mould, representing an old woman sitting with left leg bent below body; upright body; right hand holds the pendant of a necklace; very ugly face. The woman seems to be nude. Rough technique. Flat back. Height 8.3. Stray find.
1078. Fragment of a life-size, male head in dark-red terracotta; made in a mould; only right side of face preserved. Realistic expression of Lysippus type; short upper lip with small dimple in centre; straight nose; deep eyes with lids. Height 12.0. G 21. 15.0.
1079. Upper part of a bearded head of life-size in dark-red terracotta; broken off obliquely across face from left temple to right cheek. Back of head missing. Straight, powerful nose; small, deep eyes with elliptical lids. On right side, a part of the beard is visible, marked by small, impressed dots, or short, incised lines. Hair is roughly sketched; wreath in hair, partly preserved. Height 17.8. G 21. 15.0.
1080. Plaque of white marble, on one side provided with an inscription arranged in four lines. The edges are chipped (See Appendix III). Height 15.0. Width 12.0. Thickness 6.7. I 24. 20.0.
1081. Female head of brown terracotta, broken below neck. Short, powerful neck; oval face with prominent chin and nose; thin, arched mouth; small, elliptical eyes with modelled lids; large, circular, concave ears. Hair parted in the middle and combed back; wreath in hair, partly preserved. Large, circular hole on top of the head. Height 14.0. D 22. 18.0.
1082. Upper part of a bearded archer in red terracotta, broken off at body. Body and head turned to the left; left arm outstretched holding the bow (now missing); right arm bent over the breast holding the bow-string. Face is smiling; of archaic type; slightly concave nose; eyes without lids; conventionalized front-hair. Head-dress, as No. 934. Black painted hair and beard. Height 17.3. F 21. 24.0.
1083. Head of a large terracotta horse; broken off at neck. Upper part of mane missing; short nose with faintly modelled eyes and small nostrils. Length 11.1. F 21. 22.5.
1084. Fragment of a flat, male statue in soft, grey limestone. Lower part from hips, left hand, right forearm, and head missing. Surface very much worn. The figure wears a vertically folded chiton and a himation hanging over both shoulders, and open over breast and abdomen. Flat, unsculptured back. Traces of fire. Height 27.5. Shoulders 18.0. Breast to back 5.4. D 21. 30.5.
1085. Upright, female statue of very soft, grey limestone. Feet and head missing. Summary work. Isolinear feet; upright body. The hands carry an oblong object possibly a tray in front of the abdomen. The statue wears a long, vertically folded tunic. Flat, unsculptured back. Height 13.9. Shoulders 6.7. Breast to back 3.3. F 21. 23.5.
1086. Upper part of a statue of hard, grey limestone. Lower part from the waist missing. Much worn. Face is bearded; a laurel wreath in the hair. The figure is draped in a chiton and himation. Height 88.0. Stray find.

1087. Lower part of a bearded head of coarse, red terracotta, entirely black inside and covered by a thick, red slip. Forehead with left eye and ears, and back part of the head missing. The full beard is rounded, the curls being produced by tightly placed, small knobs of clay. A thin, downturned moustache frames the sensitive mouth. Deep eyes with low, prominent brows. Height 17.0. Stray find.
1088. Male head of coarse, red terracotta with black inside. Broken at neck; back part of head, right part of neck, and parts of the wreath missing; nose, chin, left eyebrow, and left ear chipped. Rounded face with full chin and cheeks; straight, stiff mouth; large, elliptical eyes; bulging, wide forehead. Short, curly hair worked in a roll round forehead by irregularly placed, small holes. Wreath round the head. The face is modelled. Height 21.0. Temples 11.2. Stray find.
1089. Inscribed block of hard, grey limestone. The general shape is parallelepipedic with a widening cornice at top. The height is intact. The front side with the letters chipped (See Appendix III). Height 19.5. Width 13.2. Thickness 15.4. Stray find.
1090. Fragment of a bearded mask in dark-red terracotta; over life-size; only left side with the eye preserved. Smiling expression; elliptical eye with lids in high relief; wrinkled forehead; heavy moustaches and beard, marked by means of parallel grooves ending in small spirals; very small ear. Height 22.8. F 17. 11.0.
1091. Male head of soft, white limestone; broken below the chin, and obliquely at the left side of the head. Tip of nose missing. Oval face with smiling mouth. Straight front- and nose-line; eyes without lids in shape of myrtle-leaves. Conventionalized front-hair worked to a row of small spirals. Wreath of laurel-leaves in the hair. Height 10.3. F 17. 13.0.
1092. Male head of soft, white limestone, broken through the wide neck. Rounded face with prominent chin, smiling mouth; short, wide nose (damaged); eyes with lids in shape of myrtle-leaves; low forehead. The front-hair is stylized; short hair on the back of head. Over the crown, the hair is indicated by incised lines radiating from a point on the nape of the neck. The front-hair is held together by a band decorated with two incised, wavy lines. Traces of red paint on the lips. Flattened back. Height 11.5. Total width 9.5. Temples 8.4. F 17. 12.0.
1093. Female head of coarse, red terracotta, covered by a red slip. Broken off at neck; back of head and right side, missing. Oval face, pronounced chin; straight nose and forehead; fairly deep eyes with lids and low brows. The hair is parted in the middle and combed back. Over the crown is a diadem. The ears are almost hidden by the hair. Traces of black paint on the hair. The face is modelled, but carefully worked over. Height 23.9. Temples 10.0. F 17. 12.0.
1094. See No. 1074. G 19. 25.0.
1095. Male statuette of yellow terracotta; head missing. Small, irregular base. The man rests on right leg, with left leg slightly bent; upright body; right arm along side; left arm bent over the breast. Short-sleeved chiton and a folded himation fastened over right shoulder by means of a fibula. The statuette is made in a mould, and has a large, square hole on the back. Height 12.5. G 21. 41.0.
1096. Bearded terracotta statuette; part of a chariot-group. Upright, cylindrical body; arms, partly missing, out-turned; nose missing; conical head-dress. Height 11.0. H 21. 14.0.
1097. Male head of soft, white limestone, broken off at neck. Face slightly damaged. Oval face with pointed chin and faintly smiling mouth; straight, almost vertical nose; large eyes without lids; conventionalized front-hair and short, grooved hair on the nape of the neck. Laurel wreath in the hair. The hair on the crown and on the back is marked by zigzag-notches. Height 10.3. Temples 5.4. Forehead to back 6.4. K 25. 9.0.
1098. Fragment of a bearded head of life-size; dark-red terracotta. Only lower part of left side with eye, nose, and mouth preserved. Realistic face; aquiline mouth; powerful nose; eyes shaped as semicircles. Short, full beard and moustaches, marked by irregular impressions by a pin. Just at the chin, the beard has fallen off. Height 15.0. K 24. 9.0.
1099. Much worn, male head of white, soft limestone. Oval face with slightly pointed chin; smiling mouth. The head is so worn that the rest of the face cannot be described in detail. Laurel wreath in hair. Height 15.5. P 16. 39.0.
1100. Base for a statue. Hard, grey limestone. On one side, there is an inscription arranged in three lines (See Appendix IV). Height 17.3. Width 35.4. Length 43.1. M 24. 11.0.
1101. Lower part of a male statue of hard, grey limestone standing on a trapezoid base. Upper part from hips missing. The figure rests on left leg, with right leg slightly bent. Across the thighs, a vertically folded himation hangs to below the knees. On the feet, there are carefully sculptured sandals tied around the ankles and provided with pieces hanging over the upper sides of the feet. These pieces are decorated with incised lines. The legs are not sculptured free from the background, but the wall remaining is very thin. Flat back. Height 40.7. L 25. 11.0.
1102. Fragment of marble slab with curved, palmette ornaments. The marble is rather coarse-grained and blueish-white in colour. On three sides, there are breaks; on one, the edge is flat and straight sawn; back is roughly bevelled. On upper side, parts of two different palmettes are preserved; one turned from the straight edge; the other towards it; the palmettes are inscribed in double-contoured fields. The technique of the carving is very minute and delicate. Height 15.0. Width 17.9. Thickness 3.4. Stray find.
1103. Upper part of a large statue in terracotta; left hand,

fingers of right hand, and head missing. Some minor pieces restored on right side of breast and below left arm. Upright, powerful body; both forearms somewhat raised. Chiton and himation sculptured with vigorous folds in a rather realistic technique. The chiton is vertically folded. The himation hangs over left shoulder, obliquely across the body. Four back-holes. Height 64.5. Width 60.0. Breast to back 31.0. F 13. 35.0.

- 1104 Bronze coin *Obverse*: Head of Ammon, r; *Reverse*: Aphrodite, standing on a moulded base; wearing girdled chiton and high head-dress; right arm raised to breast, around, inscription *ΠΤΟΛΕΜΑΙΟΥ ΒΑΣΙΛΕΥΣ*. Diam 2.5. Weight 11.5. Stray find
- 1107 Bronze coin *Obverse*: Head of Zeus, r; *Reverse*: Zeus, standing, turned left, holding sceptre in left hand and thunderbolt in right hand, outstretched. Above, star. Around, inscription, illegible. Diam 1.6. Weight 1.6. Stray find

CLASSIFICATION OF FINDS

Marble sculpture (Pl. CX).

The relief, No. 659, is certainly of Greek origin. According to Dr. E. Kjellberg the relief, though generally of Attic style displays some provincial traits.

Stone sculptures.

Material.

On examining the sculptures of stone, they can easily be divided into two groups as to the material they are made of. There is a kind of soft limestone which is very similar to that used for the Vouni sculptures. Its colour is white as chalk at the break and very fine grained. The consistency is soft, sometimes so soft that it easily was damaged, even with the most careful cleaning. After a short time in the open air it dried up and grew harder. At the same time, however, it easily fell into pieces like thin slices. The patina usually is grey, and whitened after a cleaning with water. Some pieces of this kind is of a somewhat harder consistency; it has a tendency to crumble.

The second kind of limestone used for the statues is entirely different to the soft. It is very hard like *poros*. All through the stone, there are a great many small cavities. The stone is also full of shells, usually of very small size (See Appendix VI). In this respect, it is rather similar to the Numulithic limestone of Egypt. The colour of the stone varies somewhat: usually it is yellowish-grey, never perfectly white at the break as the soft limestone; sometimes it has a dark, yellow tint, especially when it is mingled with sand. The patina is grey or reddish-grey. Both these kinds of stone were probably quarried in Paradisotissa, where ancient quarries were recognized. The hard limestone may also have been brought from the plain of Mesaorea, where, in our days, a similar kind of stone is quarried in many villages.

Concerning the sculptures of soft limestone various styles can be recognized, which, evidently should be ascribed to various epochs. As only a few complete statuettes were preserved, or could be put together from pieces, a certain difficulty arises as to which type of heads should be connected with a certain type of body. The complete sculptures preserved are, however, very characteristic, so the following establishment of the styles does not seem too bold. It is, too, confirmed by the circumstances of many other places.

Soft limestone.

Style I (Nos. 712, 834, 1070; Pl. CXI).

This style is represented by a small group of sculptures, showing the same features as the Vouni series of Style I. The sculptures are carefully worked all round. The bodies are vigorous with powerful muscles, and especially the backs look almost exaggerated. Only one head is preserved (on No. 712). It is somewhat triangular in shape, of distinct Archaic character, the mouth is smiling. The hair is long and falls down on the nape of the neck.

Style II (Nos. 711, 717, 749, 791, 866, 879, 892, 914, 1015, 1022, 1091, 1092, 1099; Pls. CXV—CXVII).

As regards this style, too, it would be possible to separate earlier and later sculptures from one another and divide the group into two classes, but as the sculptures ascribed to this style are comparatively few they are treated as a unit. Only two bodies were preserved, both of minor statuettes. They have isolinear feet, straight, upright body and plain himation. The heads are all characterized by the Archaic smile in different stages of development. The smile is much pronounced on heads, Nos. 1091, and 1092, while it has passed into a later stage on Nos. 717, and 866. The heads are oval in shape, or egg-shaped, sometimes with a somewhat pointed chin. Though the proportions of the heads are fairly good, their backs are always somewhat flattened. Sometimes the hair on the back of the head is carefully worked, but usually it is only roughly sketched. The eyes are, more or less, in the shape of myrtle-leaves usually with sculpturally marked eyelids. The hair is short and arranged in different ways: either parted in the middle, or with a row of small curls over the forehead. There is always a vine in the hair.

The chariots are worked in a minute technique. The face of the driver of No. 879 has a typical Archaic expression. The other chariots are rather damaged, but the technique in which they are worked reminds one of the small stone statuettes found at Vouni.

Style III (Pls. CXXVI—CXXVIII).

As regards the statues of this style, two groups can be distinguished called III A and III B, the latter being typologically later than the former.

Nos. 633, 719—743, 737—823, 810, 812, 825, 947, 983, 1013—1051, 1052, 1060—1061, 1062, 1074—1094, 1097 are ascribed to III A; while Nos. 614, 641, 811, 890, 1030 are ascribed to III B. The sculptures of Style III A show a direct development of Style II B. The bodies are upright with almost isolinear feet. The back is flat, but the fore-part of the body and especially the breast is well rounded. The folds of the himation are worked in a very soft technique with each fold being convex in section. The himation folds are arranged almost vertically, oblique across the body. From this rule No. 1062 constitutes an exception. The sharp-ridged folds on this statue are distinctly different, though they are carefully sculptured in rather high relief. Sometimes the chiton is fluted with deep, vertical grooves marking the folds. As regards the heads, many characteristics are noted which indicate a de-

generation of Style II. The fine Archaic smile of that style has here changed to a faint smile. A characteristic change as to the shape of the head is also noticeable: the proportions of the face and the fore-parts of the head are fairly good, but this holds good only to about the ears. Almost behind them, the head is cut off and somewhat flattened. As a rule, the details of the face are more conventionalized than in Style II. The eyes are often in shape of myrtle-leaves, some of them with sculpturally marked eyelids. On all specimens the hair is short; it is not parted in the middle, but arranged in one or two rows of conventionalized curls. As a rule, there is a wreath in the hair. — The sculptures of Style III B in general show a further development of the previous style. The folds of the himation are kept in a technique entirely in the nature of design. The folds are not, as in Style III A, modelled with high relief and convex upper side. They are simply grooved with a curved chisel. The heads, too, show a more advanced development: the smile is very faint, there is hardly any life in the expression of the face. All the heads are wreathed; the backs of them are similar to those in Style III A. Some of the heads have conical head-dress.

Style IV (Nos. 605, 650, 660, 742, 746, 817, 832, 843, 856, 894, 923, 948, 961, 1003, 1024, 1031 + 1072, 1053, 1071, 1084; Pl. CXXXIII).

Though there exists a certain difference between typologically earlier, and more advanced specimens of the sculptures ascribed to this style, the monotony is striking. Everything points to a very degenerate style, and the stages of degeneration here called Style IV A and IV B only mean a gradation. As a matter of fact, Style IV B is only represented by a few heads as Nos. 605, 660, 742, 746, and 1024. The rest are attributed to Style IV A. The bodies of the sculptures ascribed to IV A do not vary much from those of Style III B. The feet are almost isolinear and placed on a very sloping, small base; the legs nearly straight. The folds are marked by incised, careless grooves made with a pointed instrument, or a similar, curved chisel as was used on the sculptures of Style III B. All the bodies are very flat, plank-shaped. As to the heads, too, the stylization is brought still further than in the previous style. The shape of the head is the most characteristic feature. As in the previous style, the back is flat, but now the face, too, is flat; the nose is absolutely vertical almost aligned with the point of the chin. As the face is a long oval in shape, the proportions of the head are very different from the natural. In proportion with the height of the face, the distance from forehead to back is far too small. The smile has entirely disappeared, and is substituted by two thin ridges for lips. The cheeks look full and slack. The eyes are simply marked as two oval pellets. The hair is usually arranged as in the previous style. In the sculptures of Style IV B, the degeneration is carried almost as far as is possible. The general outlines of the sculptures are like those of Style IV A. The bodies, however, are almost plain, and the details of the faces are reduced to a minimum. Nos. 742 and 746 have no sculpturally marked eyes at all. On other specimens the eyeballs are sculptured flat, or even concave. The latter shape is a feature characteristic of Style IV B. The hair is indicated by means of short, transverse lines separating the curls. Two heads have

conical helmets (Nos. 605 and 1024). This style, here exemplified by a few specimens only, is richly represented in other Cypriote shrines.

Hard limestone.

The sculptures of hard limestone show distinctly different features both as regards their style, and as regards the technique in which they are worked. There seems to be only a faint relation between the previous and the following styles. The latter all bear strong marks of Greek-Hellenistic influence, while the former are dependent on earlier, local Cypriote styles and show a pronounced degeneration of the Cypro-Archaic styles.

Style V (Pls. CXXXVII—CXLI).

The sculptures ascribed to this style can be divided into two typologically separate groups, the earlier and the later. Style V A is represented by Nos. 616 + 1039, 619, 676, 704, 706, 707, 1026, 1068. Style V B by Nos. 608, 609, 612, 620, 699, 1047, 1065, 1067, 1101.

The sculptures of Style V A are carefully worked all round. The backs have not been neglected by the artist. The attitude is free and sometimes elegant. Usually, the bodies are very powerful and vigorous with well detailed muscles, especially on nude specimens.

The three-dimensional shapes are almost exaggerated and the bodies which are sometimes fat, form a good contrast to the flat, plank-shaped statues of the previous style. Some of the heads are remarkable as they can easily be fitted into the series of Greek-Hellenistic sculptures. The head, No. 616, is clearly influenced by Skopas' or Lysippus' tradition, though it is no doubt of Cypriote origin.

The sculptures of Style V B are closely connected with the previous ones. A characteristic difference, however, is noticeable. The sculptures are not worked with the same care, all round; the backs are neglected, sometimes roughly worked, sometimes unsculptured, or even flat. The front, however, is always well rounded and three-dimensional. The bodies are not so well proportioned as in Style V A, they are short and wide, rather clumsy. The folds of the draped statues are stiff, but realistic. Two of the statues are absolutely identical (Nos. 608 and 699). Others are rather carelessly worked with roughly marked folds (Nos. 612, 1067). Unfortunately, on none of these statues the head is preserved.

Style VI (Nos. 610, 618, 624, 637, 658, 669 + 1043, 693, 695 + 739, 701, 705 + 723, 727, 1035, 1044, 1045, 1066, 1069; Pls. CXLII, CXLIII).

This style shows a further development of Styles V A and B. The attitude of the statues is the same, but the technique has changed considerably. The figures are stiff, or clumsy, some of them being of a very poor workmanship. The statues are placed on a small, sloping base. The three-dimensional bodies of the previous styles are here replaced by rather flat bodies. The backs are always flat and unsculptured. The folds of the himation are carelessly worked, on the basis of the scheme developed in Style V. The heads are sculptured all round. They are round with full cheeks. The base of the nose is usually wide, but otherwise there

is a great difference between heads of this style and those of Style V. The hair is conventionalized with short, parallel curls. One head, No. 637, is given with a childish smile.

Style VII (Nos. 808, 972, 974; Pl. CXLIV).

Though represented by only a few sculptures this style must be distinguished from the others. Its characteristic features are very typical; the heads are not sculptured all round; a break on the backs of them indicate, that they were originally sculptured as reliefs on plaques. The faces are very fat with full cheeks and chin. All the details of the face are somewhat exaggerated. The chin and the lips are protruding; the eyes are very deep with bulging eyeballs; the eyes are cut in a coarse technique. The short hair is roughly sketched, and was possibly worked in detail with supplementary plaster. On No. 974, the lines are sharp, carved in a very characteristic manner. Similar features, but not so pronounced are noted on No. 1035 of Style VI. Style VII has only few representatives among the sculptures from Mersinaki, but in Soli the style is represented, too.

The description of the styles has clearly shown that Styles I—IV are entirely combined with the soft limestone. Not a single sculpture of hard limestone can be attributed to these styles. As a rule, on the contrary, Styles V—VII are combined with the hard limestone, but here we find some exceptions: Nos. 676, 744, 1026 are assigned to Styles V—VI though their material is a somewhat softer limestone.

But the styles are not only separated on account of their material. A glance at the plans will be enough to find that there also existed a local difference between the styles within the area excavated. Nearly all the sculptures of soft limestone were found in the western part of the excavation, concentrated especially on the floor between Pits V—VIII. Only a few pieces of soft limestone were spread to the eastern part (Nos. 712, 717, 746, 974, 1051, 1052). The sculptures of hard limestone, on the contrary, were all — with the exception of No. 808 which was a surface find — in the eastern part most of them, in and above Pits II—IV. It is possible that this means also a chronological difference. For while the typologically earlier sculptures of soft limestone rarely are mixed with those of hard limestone, the latter, typologically later, are never to be found among the sculptures of soft limestone in the western part. This may be a sign that the destruction of the site took place on two separate occasions. At first, the sculptures of soft limestone were destroyed and partly spread out on the floor between Pits V—VIII; secondly, the sculptures erected in the meantime, viz. those of hard limestone were destroyed and partly removed. Possibly these statues were erected close to the place where they were found, or more to the E. of the others. All the pits, however, must have been dug contemporaneously, and consequently in connexion with the last destruction.

Minor limestone plastic (Pl. CXLVIII).

Among the minor sculptures which could not be associated with any of the styles there is only one human sculpture (No. 835). The others represent animals; No. 696, a horse's head; Nos. 756 and 875, cocks; No. 700 a seated sphinx.

Indeterminable stone sculpture.

Some of the stone sculptures cannot be ascribed to any of the styles mentioned above as they are too fragmentary. These are Nos. 663, 691, 702, 734, 744, 771, 790, 802, 838, 842, 844, 885, 893, 924, 969, 987, 1007, 1008, 1023, 1033, 1040—1042, 1041, 1050, 1058, 1073, 1075, 1085. 1086.

Terracotta sculptures.

The classification of the terracotta sculptures is much more difficult than that of the stone sculptures. This is partly due to the circumstances that the bodies of the sculptures are very monotonous in shape and with the exception of a few of them, do not vary much from time to time. The heads, on the contrary, are provided with faces which usually were made in moulds. At least in some cases, these moulds were not of Cypriote origin, but show a more or less pure Greek expression. In consequence, there are some sculptures which do not follow the general development of Cypriote sculpture established on a basis of the stone statues. Heads made in these foreign moulds were placed on bodies of local, Cypriote type. Sometimes the heads were worked over and changed somewhat. In such cases, the result was a queer, hybrid style: the statues consisted of a Cypriote body with a Greek head in some way altered in accordance with the Cypriote artist's mind. In other cases, the elements of the sculptures, body and head, were in no way made to harmonize with each other. The Cypriote trunk-shaped, wheel-made bodies form a queer contrast to the Classical, Greek heads. When, on the following pages the various styles are characterized it must be born in mind that the styles to a certain degree differ from those established as regards the stone sculptures. No doubt, however, the development runs parallel, though the different materials want different technical treatment and — to a certain degree — on account of this difference, stylistic features.

References to the styles in terracotta will be given with the letter T. before the number of the style, while the style in stone are indicated with an S.

Style I (Nos. 635, 679+807, 680, 767+846+869+911, 955; Pls. I, CXII—CXIV).

The heads of this style are characterized by a very much pronounced, Archaic smile. Chin and nose are prominent and the eyes somewhat oblique, often with large, protruding eyeballs. The expression of the faces is vigorous. In two cases, the bodies are preserved. No. 767+842+869+911 has almost horizontal shoulders giving a peculiar shape of the whole attitude.

Style II (Pls. CXVIII—CXXV).

Concerning this style, two different groups are distinguished. To the typologically earlier style, called Style II A the following numbers are ascribed: Nos. 611, 687, 722, 759+787+905+975, 820, 854, 867, 872, 899, 902, 960, 976, 990, 1012, all of them large, male heads the majority being bearded. Further the following series of female statues of smaller

size: Nos. 640, 667—774, 760, 769—782, 772, 784, 793, 799, 806 · 815, 813, 822, 830, 851, 862, 897, 925, 935, 964, 981, 989, 1028.

Style II A shows a further development of the preceding style. The faces are always made in moulds. The pronounced, Archaic expression is here softened. Though the smile is still typical it has distinctly changed from the almost wild grimace of Style I. The male heads are usually provided with a long, plain full beard. The nose is thin, long, and carefully shaped, never prominent as in Style I. The eyes are characteristic. While they were provided with sculpturally marked eyelids in Style I, they are here only faintly indicated. No doubt the details of the eyes were painted. In this respect, most of the female heads are different. Usually on these, the eyes have sculpturally marked eyelids. The female heads are all of smaller size and show a rather uniform type. The face is somewhat rounded in shape; the mouth has a very pleasant smile. The same kind of wavy hair is found on most of the female heads. As in Style I, the bodies preserved are plain and, as regards the smaller statues, wheel-made, and somewhat depressed from in front. The whole expression of the statue is concentrated in the head.

A small group seems to be typologically later. It is here called Style II B. To this the following sculptures are ascribed: Nos. 604, 645, 763—766, 785, 821, 833, 864, 891, 958, 982, 988, 1055, 1064.

Some of the heads of this group might have been made with similar, or even the same, moulds as the female heads of Style II A, but they have later been altered, or worked over in a certain, typical way. In some cases the smile still exists, but in others the smile is so faint that it is hardly distinguishable. The faces are sometimes flat and clumsy, and the details are never so distinctly delineated as in Style II A. The correct explanation for these alterations seems to be that only worn moulds were used and, consequently, the faces had to be worked over in the way mentioned. The fine bearded statue No. 982 is referred to this style as it forms a transitional type between the Style II A and Style III. The curls of the beard are indicated by means of small circular impressions. It shows, however, only few characteristics of degeneration. The bodies are of the same shape as in the previous style.

Style III (Nos. 626, 634, 664, 694, 710, 713, 761 + 800 + 818 + 950, 768 + 840 + 1014, 841, 845, 973, 1057, 1103; Pls. II, CXXVIII—CXXXII).

The most characteristic feature of this style is, again, the mouth. The smile has here disappeared entirely, but the mouth has not yet obtained a natural expression such as is characteristic of the following style. The lips are usually very thin and stiff, and this imparts to the whole face an expression of stiffness. The eyes are usually provided with sculpturally marked eyelids though on the larger heads the eyes are only indicated by means of paint. Beard and hair are added subsequently to the moulded face as a mass of small pasty curls. The beards thus have not the thin, plank-like shape of the previous styles. The bodies, too, show a development of those styles. In Style I, the bodies were rather depressed from in front. In Style II, the large statues are provided with a very heavy breast which, however, rapidly tapers downwards. The large statues of Style III, Nos. 761, etc. and 768, etc. show a

well rounded body all down to the legs, and for the first time the raised right arm on No. 761, etc. is sculptured free from the body. This statue seems also otherwise to show the typologically latest features of the group, and forms a transitional type to the next style.

No. 1103 shows many features which remind one of the body of No. 761, etc. the same general outline, the same way of sculpturing the right forearm free from body. But there is a certain difference as regards the drapery. No. 1103 has a rather realistically draped tunic and himation, which are different to all the other life-size statues preserved.

Style IV (Nos. 617, 622, 630, 632, 647, 655, 656, 662, 668, 670, 685, 686, 709, 736, 738, 883, 896, 901, 903, 1063, 1078, 1087, 1093, 1098; Pls. CXXXIV—CXXXVI).

The heads sculptured in this style, have all arrived at a certain stage of Classical harmony. The expression of the mouth is no doubt characterized by a clear Greek influence. All the heads are made in moulds, but usually they have been worked over, more or less. There are a great many varieties of types; male heads with and without beard; female heads of various types. The eyes are usually deep and realistically sculptured. In some cases iris and pupil are sculpturally marked. Beard and hair are sometimes, as on No. 761 etc. of Style III, indicated as small pasty curls added to the moulded face, but a typologically later technique for marking beard and hair, is by thin scratchings or notchings which give a rather realistic effect. On other heads, beard and hair are formed in the mould, but then it has often been worked over subsequently. No bodies can be ascribed with certainty to this style.

Style V (Nos. 623, 631, 647, 656, 675, 692, 698, 708, 720, 745, 757, 809, 862 a, 886, 1036, 1076, 1079; Pl. CXLII).

This style is characterized by a degeneration of the Greek features of the previous style. As a rule, the moulded faces have been worked over rather much, as it seems, in order to get a portrait-like sculpture. There are some of the heads which show a very individualistic expression. The eyes are generally not so deep as on the previous sculptures, and the eyelids are sometimes stiff and elliptical. The details of the hair and the beard are obtained by means of different techniques. Usually parts of the hair are moulded, and, subsequently, notched with a pointed instrument. In comparison with most of the heads of Style IV, these heads have a dry and stiff expression. The brick-red colour of the clay is paramount, and as a technical characteristic it may be mentioned that the walls of the hollow heads are exceptionally thick.

Style VI (Nos. 622, 654, 683, 684, 721, 752, 859, 915, 1081, 1088; Pl. CXLIV).

The sculptures ascribed to this style form a rather homogeneous group, characterized by a full expression of the faces. These are moulded and some of the heads are identical. The chin especially is full, with a characteristic sloping line below it. The mouth has a sad expression and often the corners are turned down. One of the heads has a childish smile. The eyes are often sculptured with incised iris and pupil. They are comparatively deep and realistic. The hair is carelessly indicated by grooves running backwards from the forehead.

Style VII (Nos. 677, 678, 758; Pl. CXLV).

This style is entirely different from all the others. The heads have a peculiarly primitive character. The faces are not made in moulds. Their faces are concave, provided with prominent chin and forehead. The eyes are exceptionally deep with stiff, elliptical eyelids and edged eyebrows. The mouth is indicated as merely an incised, straight line. The hair, too, is indicated as short, straight, incised lines. The whole expression of the faces is exceptionally stiff and crude. There is a similarity between these heads and those of *Style S. VII*, which cannot be accidental. They must have been inspired by the same feeling, or lack of technical skill.

Minor terracotta plastic (Pls. CXLVI—CXLVIII).

Most of the minor terracotta plastics are parts of chariot-groups of various size. The majority of them were of the same types as those found at Ajia Irini. Others were large, the horses and human figures being hollow. These are made in a very crude technique. The former group to which also other similar sculptures of "snow-man" technique are ascribed consists of the following numbers: 629, 643, 644, 646, 651, 653, 657, 666, 688, 714, 716, 726, 729, 747, 748, 753, 754, 764, 765, 779, 827, 829, 831, 837, 850, 860, 863, 871, 881, 882, 887, 898, 900, 928, 933, 943, 968, 984, 985, 986, 993, 994, 995, 996, 997, 998, 999, 1000, 1002, 1004, 1016, 1019, 1059, 1096.

The larger chariot-groups are represented by Nos. 628, 642, 649, 828, 836, 865, 876, 877, 878, 888, 895—956, 910, 912, 917—921—931—932—936—957—977, 919, 927, 934, 946, 954, 980, 992, 1001—1018, 1046, 1048, 1082, 1083. Among these are fragments of the horses as well as of the drivers.

The Athena group (No. 814—816—926—979) is made in a somewhat meticulous technique and should possibly be associated with the statues of *Style II B*.

Indeterminable terracotta sculptures.

Among the sculptures of terracotta a great many could not be ascribed to any certain style as they were too fragmentary. These are the following numbers: 607, 625, 636, 671, 672, 673, 674, 681, 689, 715, 718, 735, 762, 770, 773, 775, 776, 777, 778, 783, 786, 792, 796, 797, 798, 801, 803, 804, 805, 819, 847, 848, 849, 853, 855, 857, 858, 868, 870, 873, 874, 884—908, 889, 904, 906, 907, 909, 913, 916, 918, 920, 937, 938, 939, 940, 941, 942, 949—952, 951, 953, 959, 962—1006, 963, 966, 967, 978, 991, 1005, 1009, 1010, 1011, 1027, 1032, 1038, 1054, 1056, 1090.

As to the rest of the minor terracotta sculptures various types are noticed. Nos. 638 and 764 are solid moulded, female statuettes, whereas Nos. 615, 724, 725, 930 are heads belonging to similar statuettes. No. 613 is a male counterpart to them. Nos. 639 and 1095 display a different technique as regards the moulding. They are hollow, with very thin walls, and should be associated with Hellenistic and later terracottas. No. 652 is a small figure which, evidently, when complete, was used as a jumping Jack. Nos. 1029 and 1077 are more in the

nature of reliefs. No. 1029 represents a seated female figure wearing a crown while No. 1077 represents an old woman in seated attitude. No. 794 seems to be a fragment of a terracotta bull.

Pottery (Pl. CXLIX).

Only three complete vases were found within the excavated area. Nos. 780 and 880 are both ascribed to the class Plain White VI while No. 929 was of Plain White VII Ware. They are all jugs.

Bronze (Pl. CXLIX).

Arrow-heads.

One type represented (Nos. 627 and 852), triangular with short socket and triangular section through point.

Nails.

The nails, No. 682, are provided with large mushroom heads.

Rod.

No. 733 is a plain rod somewhat bent.

Ring.

No. 788 is a small ring with circular section.

Plaque.

No. 781 constitute fragments of a circular plaque.

Mounting.

No. 621 is a circular, disc-shaped mounting with somewhat projecting centre.

Coins.

The coins represent a very long period. The earliest dates from the Cypro-Classical period (No. 602, from Marion; cf. Hill, *Cat. Gr. coins of Cyprus*, Pl. XX, 19). Three coins of the Ptolemaic era were found; No. 603 dating from the reign of Soter (Svoronos, *op. cit.*, Pl. VI, 16), No. 1104 from the reign of Euergetes I (Svoronos, *op. cit.*, Pl. XXX, 18), and No. 691 from Arsinoe III (Svoronos, *op. cit.*, Pl. XXXIX, 4—7). There is also a Roman coin of the period of Gordianus Pius (No. 731). No. 1105 seems to be indeterminable.

Terracotta lamps (Pl. CXLIX).

The lamps represent three entirely different types. 1. No. 965 belongs to the old Cypriote type of shallow lamps with rounded base and pinched nozzle. 2. Nos. 606 and 648 are of the Hellenistic type with base-ring, and biconical body. The nozzle is long and almost horizontal. 3. No. 971, finally, represents the Roman type of moulded lamps with volute nozzle. On the disc there is a love scene in relief.



Fig. 199. Mersinaki. Finds *in situ* in Squares J 19 and H 19.

B e a d s (Pl. CXLIX).

No. 789 is a circular bead of bone pierced by a large hole. No. 861 is of blue faience, striated and provided with a wide string-hole, whereas No. 730 is of multi-coloured glass and circular in shape.

C a r v e d m a r b l e s l a b (Pl. CXLVIII).

No. 1102 is a fragment of a marble frieze decorated with carved palmettes.

I n s c r i p t i o n s (Pl. CXCVIII).

As regards the inscriptions, No. 740, 750, 751, 839, 1037, 1080, 1089, 1100, see Appendices III—IV.

As has been pointed out in the descriptions of the styles of sculpture, a continuous development can be followed from one style to another. As regards the stone statues, there is a marked break between Styles IV and V which is still more accentuated on account of



Fig. 200. Mersinaki. Finds *in situ* in Square J 19.

Fig. 201. Mersinaki. Finds *in situ* in Square K 20.

the change of material which has been pointed out above. Styles S. I—IV show a gradual, continued development from the early, rounded, Archaic statues, to the plank-shaped statues and their extreme degeneration. The fresh naturalism of the Vth style forms a marked contrast to the flat bodies and heads of the preceding one. No doubt this change is due to fresh influence from elsewhere than the preceding, local, Cypriote styles. As Style S. V most closely can be connected with Greek sculpture at the time after Alexander, there can be no question where Style S. V originates. Style S. VI is characterized by a degeneration of the preceding one, and it is interesting to find how the degeneration in both cases takes place in a very similar way: the bodies are becoming flatter, the proportions of the heads are changed; at the beginning of the development, the bodies are three-dimensional, plastic; at the end they are flat, two-dimensional, the details being obtained by means of a delineating technique.

The similarity of reaction after two periods of foreign influence must be due to the local, Cypriote spirit. Though very few Cypriote real stone reliefs exist, the whole sculptural art of the island for centuries preserved its character of relief. The sculptures are always meant to be seen from one side, usually from in front. The flat, plank-shaped statues are paramount both as regards sculptures in stone and terracotta. When, at certain epochs, the three-dimensionality is imported from abroad into Cypriote statuary, it usually is transformed in accordance with the local, Cypriote feeling after only a comparatively short period. This holds good for the earlier, Archaic styles as well as for the late, Hellenistic.

It seems impossible to explain all the peculiar characteristics of Style VII, exclusively as a further development of the previous two styles. Besides some degenerate features, there is also a crude exaggeration of certain details which must be due to influence from some other source than the previous style. These sources will be discussed in more detail in Vol.

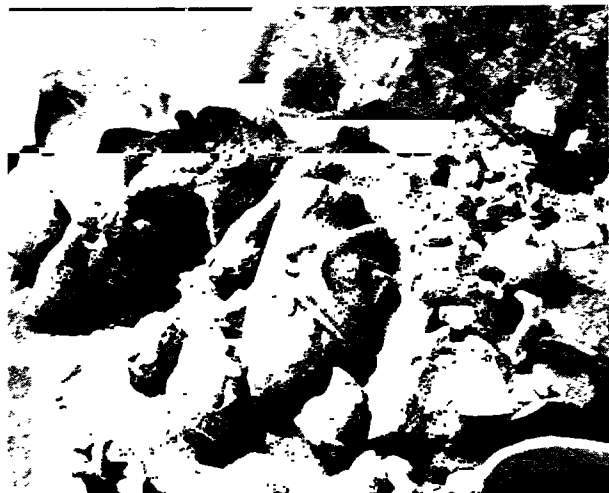

Fig. 202. Mersinaki. Finds *in situ* in Square J 19.

Fig. 203. Mersinaki. Finds *in situ* in Square L 19.

IV, but it may be pointed out here, that the style must be explained as a hybrid with sources in the local tradition suggested above, as well as from abroad.

On making a survey of the terracotta styles a parallel development is noted. As regards the bodies only, a few remarks may be made as to the general development. The limited material is not sufficient for far-reaching conclusions. The angular outline of the body of Style T. I (No. 767, etc.) is not found on sculptures from the other styles. The large statues of Style T. II have a very bulging breast; the lower part of the body, however, is somewhat flattened. The attitude is still very stiff. The two large statues of Style T. III have well rounded and very powerful bodies, which in no way correspond to the flat bodies of Style S. III. The arms are also sculptured free from the body, and are not as in Styles T. I—II sculptured from the same piece of clay as the body. A further stage of the same development is represented by No. 1103 which should probably be ascribed to Style III. Both forearms are free from the body and the drapery of the dress is sculptured with an undeniable, realistic skill. Concerning the bodies, it must be kept in mind that the different kinds of material must lead to developments on entirely different lines. The wheel-made bodies of terracotta can for technical reasons in no way be compared with the bodies of soft or hard limestone.

As regards the heads of terracotta, the circumstances are quite different. As a rule, these are made in moulds which might have been of various origin, and thus the local tradition of the development cannot be taken for certain. The gradual development is clear and unbroken in Styles T. I—III. The pronounced Archaic smile of the first style is gradually becoming fainter and disappears entirely with Style III. The purely Greek faces of Style T. IV, however, point to a new source of influence. Most likely, some of these moulds were brought from other Greek countries and introduced on Cypriote ground with its earlier, local terracotta tradition, as something strange and new. These heads of Style T. IV form a sharp contrast to the sculptures of Style S. IV, which still follow the old

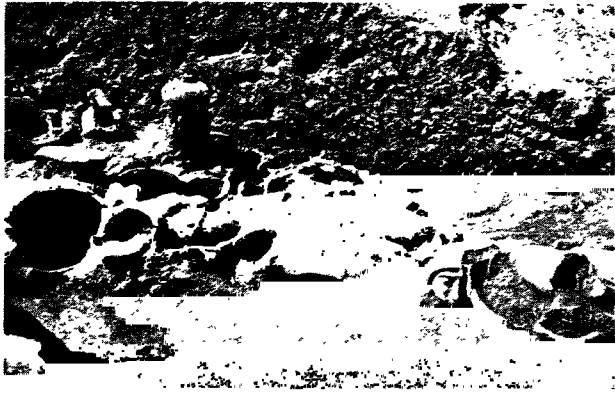

Fig. 204. Mersinaki. Finds *in situ* in Squares I 20—21.

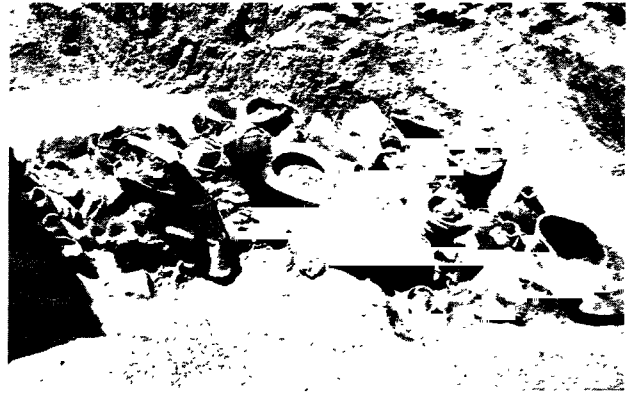

Fig. 205. Mersinaki. Finds *in situ* in Pit V.

Cypriote tradition with all its features of degeneration. Thus, there is a marked discrepancy in the development of the two series. The fresh naturalism is noted in both cases, but while, as regards the stone sculptures, it appears for the first time in Style V, it sets in already in Style IV as to the terracottas. That this means a chronological difference, too, is confirmed by the fact that the bearded, Greek heads of terracotta (Style T. IV) represent an earlier stage in the evolution of Greek, sculptural art than the heads of stone (Style S. V) e. g. No. 616. Under such circumstances, the following conclusions seem to be correct: The great change in the development took place between Styles IV and V. The new three-dimensional style, however, had some forerunners in the imported moulds for the terracotta heads. These must have been of great importance as preparing the ground for the new, coming style. After a short period of close relation to Greek sculptural art illustrated by Styles T. IV—V, the Cypriote terracottas again started its development towards degeneration, and now the styles in stone and terracotta run quite parallel. The same expression of the faces are noted in both cases, and the same break in the development between Styles VI and VII are noted both in stone and terracotta. The stylistic conformity of sculptures of stone and terracotta of Style VII shows that the same source of inspiration must be supposed for sculptures of both materials.

CHRONOLOGY

For the chronology of the styles it is necessary to take into consideration the series of sculptures from Vouni, which can be dated in accordance with the building periods of the palace. The two series from Vouni and Mersinaki seem to start contemporaneously. This constitutes the first fixed point for the chronology. The latest sculptures from Vouni are also well paralleled in Mersinaki, and in this way a second fixed point for the chronology is obtained, as the destruction of the Vouni palace can fairly well be determined. A third fixed point is constituted by the close relationship between some of the sculptures in hard limestone of Style V, and Greek sculpture of the mainland. The schools of Skopas and, to a certain degree, of Lysippos are necessarily implied in a statue like No. 616—1039. The reincorpor-



Fig. 206. Mersinaki. Finds *in situ* in Pit V.

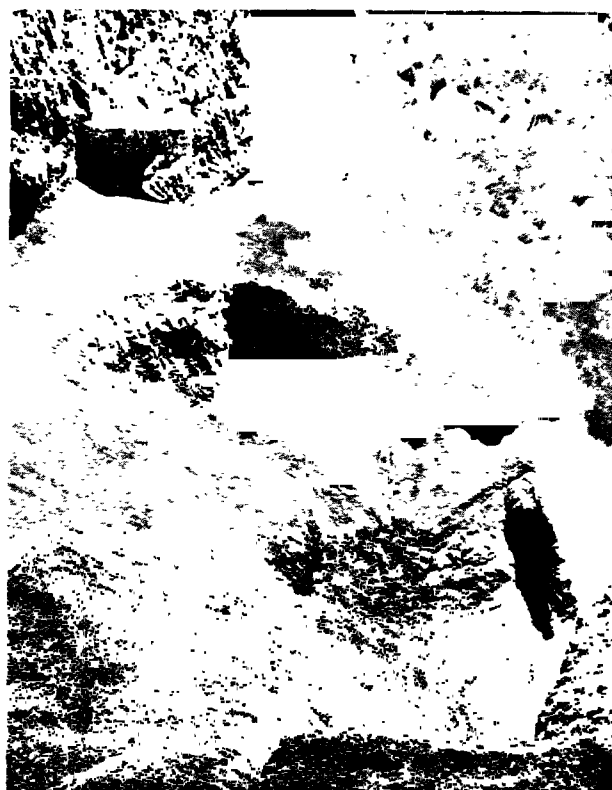

Fig. 207. Mersinaki. The bottom of Pit V, since the finds had been removed.

ation of Cyprus into the Greek, artistic world at the time of Alexander the Great would be a natural cause for a break with the old, local, Cypriote tradition in soft limestone, and the start of a new, realistic style in hard limestone (Style V). As to the close of the series of sculptures, no good fixed points exist. As Style VII is represented by a hitherto rare type of sculptures it seems difficult to find a solution for its date in Cyprus. Below, it will be argued that some of the peculiarities of this style are due to influence from Pergamene and other late Hellenistic styles, with a tendency to a certain exaggeration. The close of the series would thus fall during the first part of the 2nd Century B. C. This seems also to be confirmed by the rather scanty pottery fragments found in connexion with the sculptures.

As to the pottery found on the spot the only complete vases, three in number, could be ascribed to the Cypro-Classic I—II periods. As practically all of the pottery sherds were of plain or coarse wares which could be ascribed to any Classic or Hellenistic period, its significance for the chronology was comparatively small.

The coins, too, offer no fixed points for the chronology, as only few of them were found and these are distributed between periods from the Classic period to the reign of Gordianus Pius. As the majority of the coins were of the Ptolemaic era or earlier, and the Gordianus coin was the only one from the Roman epoch it seems reasonable that the latter coin was a mere occasional find without significance for the chronology of the site.

Style I is closely connected with the earliest sculptures from Vouni, e. g. the large, female



Fig. 208. Mersinaki. Finds *in situ* in Pit II.



Fig. 209. Mersinaki. Finds *in situ* in Pit II.

stone-head with the diadem (Vouni No. 17). As regards the terracotta sculptures, Style I apparently shows an advanced stage of the Cypro-Archaic style, as we know it from the latest sculptures of Ajia Irini, viz. those with Ionian influence (Ajia Irini, Style VII). Not only has the artistic style changed, but there is also a different technique used for the Mersinaki sculptures: their moulded faces with the subsequently added, small, spiral curls form a distinct contrast to the Ajia Irini sculptures with their primitive, smiling, irregular heads, for which no moulds have been used. The date of Style I thus is fixed to the third quarter of the Cypro-Archaic II period. At the same period, building activity started at Vouni. Sculptures like those of Style II both in stone and terracotta have also been found at Vouni. As they were found not only in the large temenos, Rooms 122—123, but also in the earth from the later addition to this temenos, Rooms 124 and 129, this style also chronologically must represent a further stage of development. In this way Style II can be fixed chronologically as being contemporary with the last quarter of the Cypro-Archaic II and the first part of the Cypro-Classic I periods. In a similar way Style III is combined with the later part of the Cypro-Classic I and the beginning of the Cypro-Classic II periods represented by the latest sculptures of Vouni. The Vouni series terminates contemporaneously with Style III; only two specimens of Style IV are represented there. For the discussion of the absolute chronology as well as for the destruction of the Vouni palace reference is made here to the IVth volume of the publication. The destruction of the palace must have taken place in the beginning of the Cypro-Classic II period. It is impossible to fix the time of the termination of the gradual degeneration of the stone sculptures of Style IV. In the Soli-Mersinaki region, they are probably soon replaced entirely by the more realistic styles, as they are not found in the temples of Isis and Aphrodite at Soli. But the possibility certainly remains, that the reproductions of similar, retarded sculptures continued to be made for another cent-

ury or more at some provincial places. The attribution to the IVth Century B. C. is quite in accordance with Greek sculpture on the mainland. Style IV is thus ascribed to the later part of the Cypro-Classic II period; the retarded specimens possibly to the very beginning of the Cypro-Hellenistic I period. The transition from Styles IV - V may be connected with the inscription, No. 740 on which Arsinoe Philadelphou is mentioned. This Ptolemaic queen showed a great interest in Cyprus. Several towns were named after her and she called herself with the name *Kypris*. It is not surprising to find her name in connexion with the building of a new temple, or alterations of an ancient, sacred place in Cyprus. This is known as to the temple of Aphrodite in Paphos. The first building activity in the temples of Isis and Aphrodite in Soli must be connected with the epoch (cf. below) and it is more than likely that the great stylistical change which has been pointed out previously is caused directly by the closer relationship between Ptolemaic Egypt and Cyprus which was established during this period. Eunostos, King of Soli, had already married Eirene, the daughter of Ptolemy Soter. The sculptures of Style V from Mersinaki are of the same kind as the earliest sculptures found in the temples of Isis and Aphrodite in Soli. A good *terminus post quem* for these temples is constituted by some tombs which are partly built over and destroyed by the first temple construction. As these tombs contained Cypro-Hellenistic I pottery, the temples in question cannot have been constructed during the same epoch, or the very beginning of the Cypro-Hellenistic I period. They must be of later date. In fact the earliest sculptures from this site in Soli, both for stylistic and stratigraphical reasons can be dated to the period of Ptolemy Philadelphus. Considering the inscription mentioned, (No. 740) the same date may be accepted for the Mersinaki sculptures. Typologically Style VI must be later than Style V and they can be compared with sculptures of a type usually ascribed to the epoch of Ptolemy Euergetes. They are of the same kind as the sculptures of Style I B from the temples in Soli, and may be dated in accordance with them.

We now proceed to Style VII. The peculiar characteristics of this style have already been pointed out. The style is not localized to Mersinaki exclusively. A similar style appears in Soli, where it can be connected with the temple of Isis. Other stray finds of sculptures which no doubt should be placed in the same group as those of Style VII from Mersinaki are known in Cyprus and Alexandria. It seems not to be too bold to search for the forerunners and the inspiration of the exaggeration of this style in some of the Hellenistic centres, most likely the Pergamene school. The relationship is certainly not very close, but the style may be explained as the local artists' attempts to follow the artistic taste of the leading cities. The large terracotta heads are no longer made in moulds. Possibly there were no moulds available. After the long period of using the moulding technique, the artists were out of practise of sculpturing large terracotta heads. This may explain some of the extremely primitive features, recognized in this style. The attempts to sculpture the eyes deep have caused the artists make the faces almost concave. The beginning of the Cypro-Hellenistic II period is the most likely date for the Mersinaki sculptures of this kind, as well as for those found in Soli. This is the termination of the series of sculptures.

The history of the place thus can be reconstructed as follows: At about the same time



Fig. 210. Mersinaki. Finds *in situ* in Pit VI.

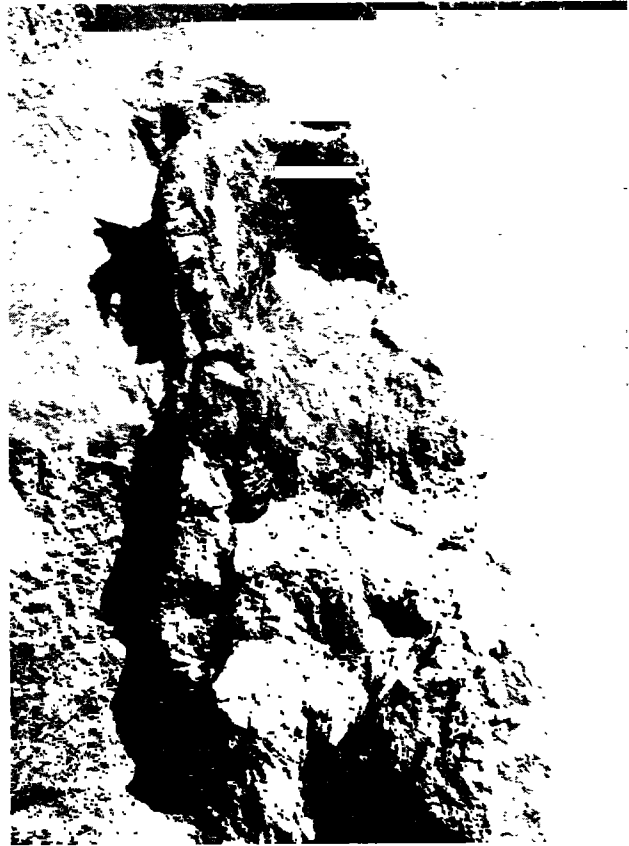

Fig. 211. Mersinaki. Carbonized olive tree on the bottom of Pit VI.

as the building activity started at Vouni the first votive offerings were placed in the sacred precincts at Mersinaki. Two of the inscriptions show that the place was sacred to Apollo. No. 1100 in Cypriote syllabary characters mentions only the name Apollo while, in the later inscription, No. 839, the offering is made to Apollon Lykios. Whether Athena, too, was worshipped from the beginning at the place or not, remains uncertain. Her name inscribed in Greek characters on a stone, (No. 1089) and the chariot-group, No. 814 + 816 + 926 + 979 indicate that she in any case was worshipped later on. The chariot-group mentioned may be ascribed to Style II. Possibly the cult of Athena was introduced at Mersinaki, contemporary with the building of the Athena temple of Vouni and the alterations of the palace, which are described as the third building period. These events took place during the Cypro-Classic I period. As to the nature of the sacred buildings erected on the spot, nothing can be said, but that they seem to have been constructed in accordance with a rectilinear system. Gradually the site became crowded by statues, the larger ones usually being of terracotta. The cult-stature of Apollo (No. 1070), however, was made of soft limestone in spite of its large size. When the hard limestone began to be used for statues (Style V), the place must have offered a very peculiar appearance: side by side stood old Cypro-Archaic statues in stone and terracotta, later Cypro-Classic statues, those of stone being plank-shaped, those of terra-

cotta having Greek, moulded heads supported by trunk-shaped bodies of local, Cypriote style. To this queer society the large, draped Greek statues of hard limestone were now introduced. They seem, however, to have been placed somewhat apart from the others, judging from the places where the pieces were found. Finally, the temple site was completely destroyed. The pieces of the sculptures were scattered about all over the ground, but evidently not removed very far from the place. Probably the place then was abandoned for a time. When, in early Roman times, the house to which Walls 4—8 belong, was constructed close to the old temple site, but on a higher level, a good many of the sculptures were buried in large pits which were excavated in the sandy layers below. Other pieces of the statues were left as they had fallen on the ground. The pieces of statues thus were mixed with the rubble from the destroyed walls. Other rubble blocks slipped down over the eastern part of the site when the house mentioned fell to pieces. After the destruction of the house, the site was abandoned entirely and from the slope above, the rains brought the heavy layers of earth over the previously sacred place. There are no signs that the place was used during subsequent periods, or that the cult was continued on a modest scale as has often been observed in regard to other sacred places in Cyprus.

A. W.



Fig. 212. Soli. General view.

S O L I

TOPOGRAPHY (Plan XXXIII)

Soli was situated on one of the small hills in the region where the plain of Mesaorea, which occupies the centre of Cyprus, between the Kyrenia range and the Troodos mountains, is transformed into low hills before the high mountains of western Cyprus. The plain reaches to the foot of the acropolis hill of the city with a narrow strip along the bay of Morphou. Only some hundred metres west of the city a rocky ridge of the mountains reaches right down to the sea, thus abruptly terminating the plain of Mesaorea. In a southerly direction, there are two distinctly marked valleys which conveniently connect the plain with rich and fertile regions higher up in the Troodos mountains. The easternmost



Fig. 213. Soli. View from Cholades of the acropolis hill. The western city gate lies just above the large olive tree in the middle of the figure.

of these begins in the district now called Marathasa, passes through the village Lefka and the district of the copper mines, already used in ancient times and opens into the plain a couple of miles east of Soli. The river of the other valley (Fig. 216) has its source not far from the monastery of Kykkho, passes through the village of Kambos and falls into the sea, west of the city, but almost within its area (Fig. 213). The situation of the town thus seems to be extremely good and have various advantages: to the north the sea and a good harbour, in fact the only good winter-harbour on the whole of the north coast; to the east the large cultivated plain, to the south almost up to the town, the most valuable copper district of the island, and further, convenient communications with rich, cultivated sites in the mountains, by means of two river valleys leading almost to the summit.

A traveller, who rides to the west along the coast will find that, on leaving the plain of Soli, the landscape suddenly changes entirely. There is a real rocky screen, which separates the Soli area from the next valley. It hangs over the sea with an absolutely vertical slope in the side of which, for long distances, the modern road has been excavated. In ancient times it must have been impossible to pass where the modern road runs in our day. As a matter of fact, there are traces of another path, running parallel to the shore about 300 metres from it over lower passages on the ridge. There is no other possibility but that the road in ancient times ran on about the same line, as it was impossible to get through along the shore. The contrast between the wide level plain, east of Soli, and the rocky, wild landscape with its steeps and gorges everywhere in this region west of the city, is apparent. The hills are, however, for a short distance interrupted by the valley

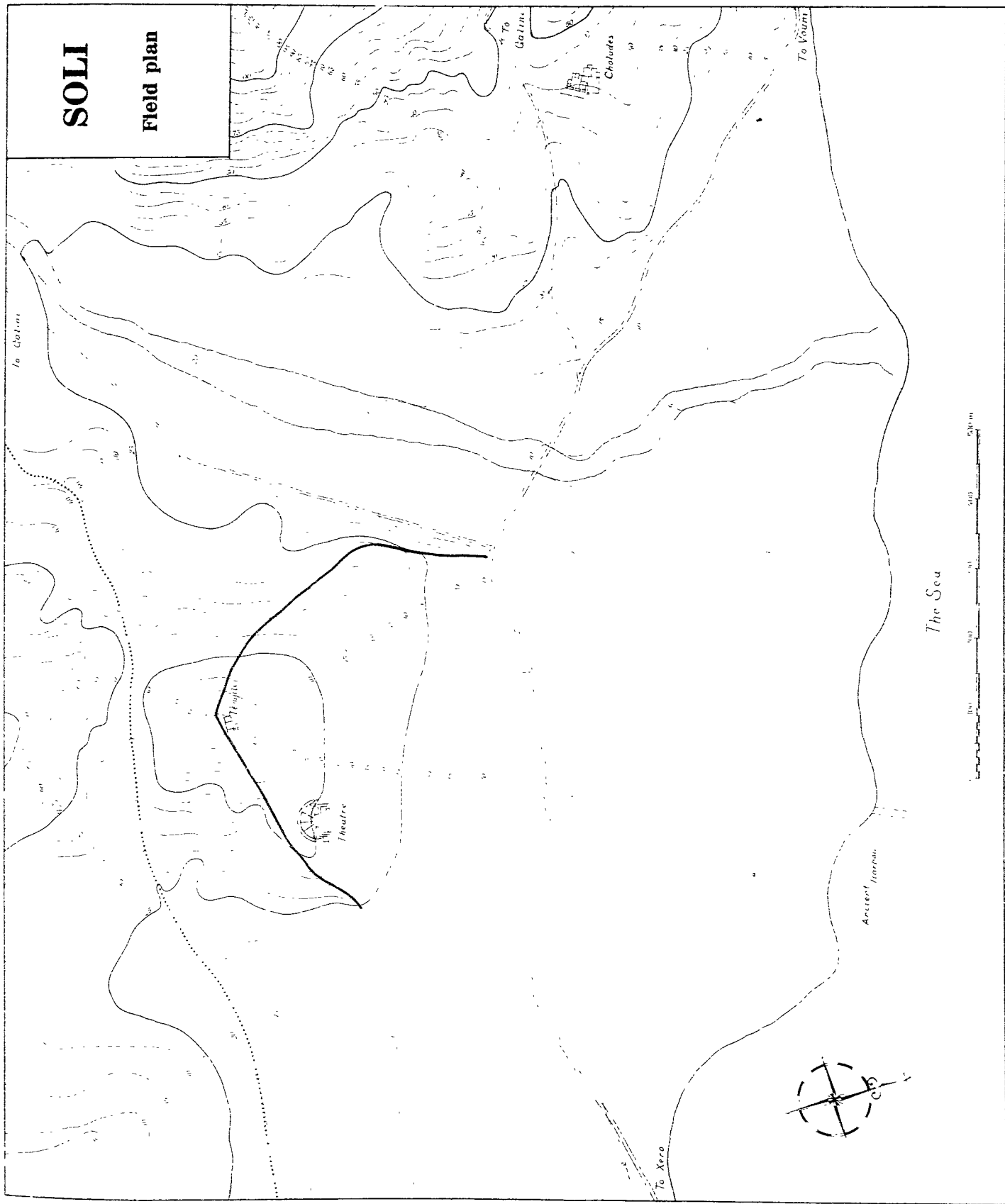

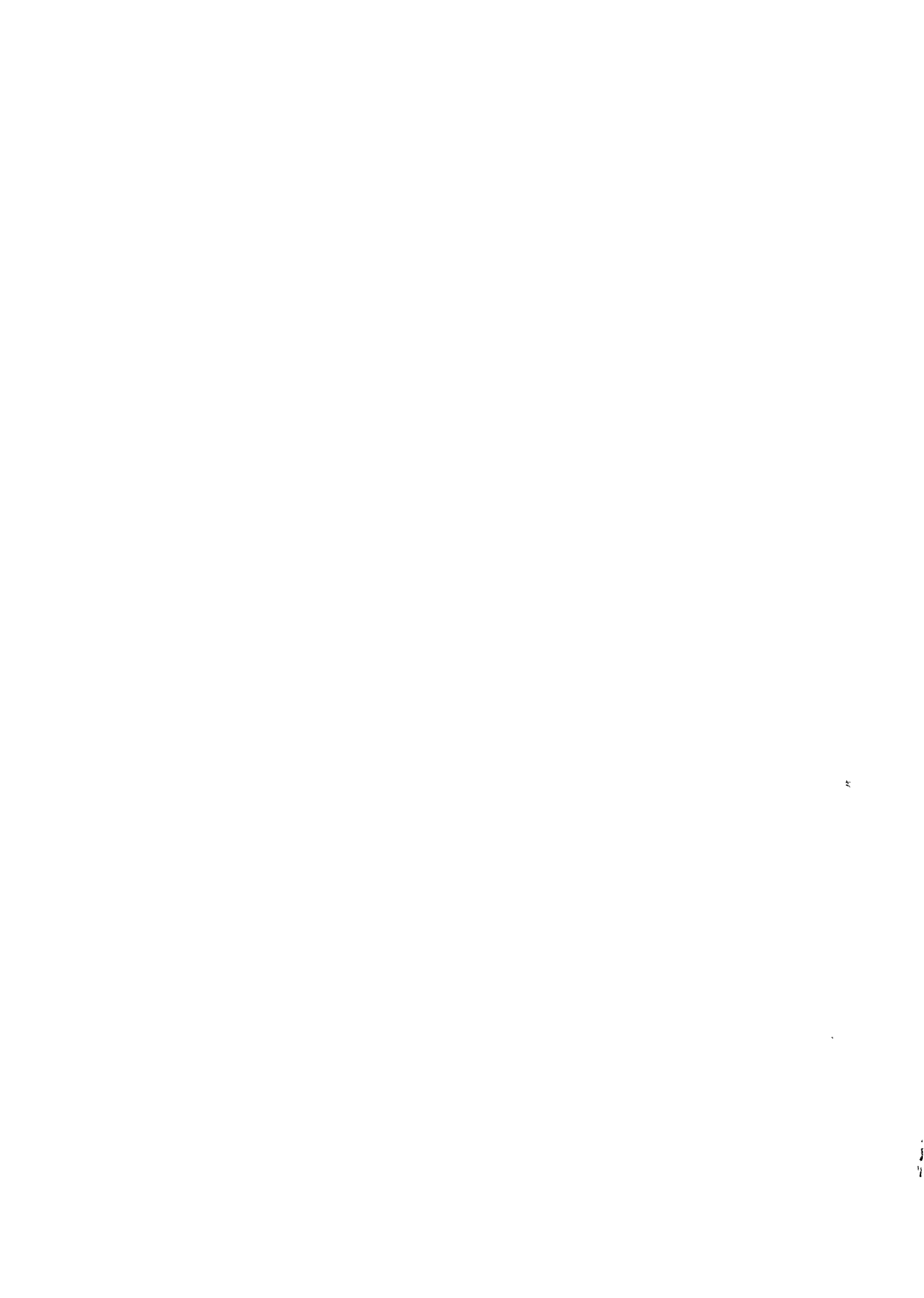



Fig. 214. Soli. View from S. E. of the acropolis hill.

of Mersinaki, which, close to the sea forms a triangular plain. Further to the west, the wildness of the country becomes still more exaggerated, especially on the slopes around Vouni. The modern road follows a small brook, which runs almost parallel to the shore south of Vouni, and this way was probably used in ancient times, too, as it leads up to the only pass over the next ridge which is a continuation of the mountain of Vouni. But, evidently, there must have been another road, too, in ancient times, near the shore.

From the top of Vouni there is a very steep slope down to an abyss hanging over the sea. Only at very low water, it is possible to pass along the beach below the vertical wall of this gorge. From the plain of Mersinaki, however, there is a path up to the back of Vouni where the great entrance to the precincts of the palace has been cleared. On this side of the mountain, the main road was situated between the palace of Vouni and the town of Soli during the palace period. From the eastern side of Vouni the ancient road can be traced straight across the slope now called Loures, and down on the western side where it is continued by the path down to the site of Paradisotissa, a small narrow valley watered by two rills. On the sides of the valley a great many caves and tombs are situated, and between

the rills at the bottom a small temple was cleared. But it seems to be possible to trace the path further to the west. Not far from the sea, it runs through the wild and steep country down to the plain or valley of Limnitis. On many sites along this path there are at present remnants of ancient houses, and the pottery found on the surface shows that these houses were in use at the same time as, or slightly later than the Vouni palace. Whether the route along the modern road from Vouni down to Limnitis was used also in ancient times or not, remains uncertain. The route described here seems to have been the ordinary communication between Limnitis and Soli. Limnitis, of course, was an important place in ancient times and the communications between this valley and Soli have been carefully traced here as they will prove to play a certain role for further discussion.

As to the topography of the city itself many conclusions can be drawn from the site itself and from the remnants preserved above the surface of the ground. The precinct of the town proper is comparatively well defined on all sides by the foundations of the city walls, which pass over the summit of the acropolis hill at a height of 70 m. To the east, the wall can be traced on the edge of the hill down to a point about 100 m. east of the theatre. There the wall disappears under ground but most likely it runs almost straight down to the sea. As a matter of fact, a large heap of huge ashlar blocks probably indicate the position of a gate through the wall. It is situated at a height of 10 m. above sea level, some 100 m. south of the road which runs across the area of the city. Probably, the city wall was continued by the eastern breakwater of the harbour which at low water is clearly to be distinguished. The western arm of the breakwater is also traceable as a line of large, badly corroded limestone blocks in the sea. Between these arms was the entrance to the ancient harbour, which now has silted up almost entirely. The circular shape of it, however, can still be seen as a low depression in the garden belonging to Ibrahim.

But we return to the summit of the acropolis hill in order to trace also the western part of the city wall. Here it is clearly visible on the surface. It runs in north-westerly direction down to a point about 200 m. south-west of the road mentioned above, where it follows the edge of the river bed almost to the modern road. Near the middle of this last portion of the wall, a gate through it was noted (Fig. 213). The western face of the wall is here rather high as it also serves as a protection against the river, which sometimes comes up to the city wall. As great damage would have been caused to the cultivated field above, the gate was never entirely cleared, but no doubt we there see the western entrance to the city. Possibly there was a bridge over the river in connexion with this gate. It is thus possible to trace the very start of the road from Soli to Limnitis at this western gate through the city wall, whence it was continued by a passage — probably a bridge — over the river, and further up along the valley on the western bank, through the same valley which has previously been described in connexion with the finding of the stone sphinx, on the place called Cholades.*

* The name *χολάδες* has proved to be difficult to explain. *χολός, -έδος* occurs in ancient Greek and the plural *χολέδες* is used in the same meaning as *ύττι*, bowels, guts (II 4526; 21.181). At Plin. (37.18) it has the meaning of a kind of smaragdus which might have been of Cypriote origin. Hesych mentions a Dionysus feast called *χολός*. Neither of these might explain the present name of the place with certainty. In Byzantine Greek *χολός* has the same meaning as *κόχλος* (cf. the

The continuation of the city wall north of the main road, remains uncertain. There is, however, nothing which speaks against the suggestion that it followed the river bank to the sea. No traces of a city wall can be seen along the sea. Of course one would not expect the sea wall along the present beach, but at some distance from it. In general there is not much to be seen above ground in these fields north of the main road.

As regards the town planning there is much to be done yet. Only a rough sketch of the distribution of the main buildings was obtained during the diggings for the temple of Isis and Aphrodite, and only rarely it proved to be possible to determine the various foundations trenched over on several occasions. When starting on the summit it could be ascertained that the very top plateau had been surrounded by a strong wall of about the same construction as the city wall. As far as could be stated, the entrance to this enclosed area had been situated on the north side, where some *poros* blocks, possibly the threshold, were found. Within this area the foundations of a *templum in antis* were cleared. Apparently the wall enclosed the *temenos* with the temple on the very top of the hill (cf. p. 412).

Statues were said to have been found in a field belonging to a certain Sophia. Here a trench was dug and a large building partly uncovered. The purpose of the building remains uncertain. Probably it should be explained as a portico. It had a concrete floor and column-bases at equal distances from each other. In the filling some fragments of a marble frieze were found, which probably should be dated to the Cypro-Hellenistic period.

Another shaft was dug just inside the western gate of the city wall described above. Not far from this site the marble statue representing the nude Aphrodite, now in the Cyprus Museum, was said to have been found. In spite of extensive diggings to the rock, which was found at a considerable depth, no remains of buildings or walls were found here. On carrying on the excavations further to the east, the remains of a house with a rough mosaic floor with ornamental designs was uncovered.

North of the modern road, between this and the sea, there are, too, remains of important buildings though they seem to be of a rather late date. Bricks have often been used for the constructions there. This is especially noted as regards a vaulted building, now almost hidden in the earth. These fields have yielded some Cypro-Roman capitals of marble still kept in the gardens. At a place called Monastiraki, close to the river bank a large and comparatively well preserved portico with marble columns was traced when searching for the Isis and Aphrodite temple (Fig. 219). It was, however, never entirely excavated. Further to the east the harbour was situated.

Certainly the town of Soli has changed very much from time to time. The earliest pot-

Arabic *kohl* and the hebrew כֹּהֵל (kohl). In E. A. Sophocles, *Greek Lexicon of the Roman and Byzantine Periods*, Cambridge 1914, it is described as a dark pigment with which women blackened the edges of their eyelids. In modern Cypriote the word *Lohēs* is usually known in the somewhat corrupted form *zohē*, the plural form of which is *zohēdes*; cf. *μιογέ*, plural *μιογέδες*, colour, paint. In modern Cyprus, the pigment is used not by the grown-up women but for paintings around the eyes of babies at certain occasions. Perhaps the ceremony of painting was connected with the locality in some way, or is the name simply explained by the numerous fragments of painted stucco which are found all over the ground? There are many names of places in Cyprus which must be explained in a similar way, such as *γέσιτες*, *γέσιου* or *γέσιουα*, which all are caused by ancient pottery fragments visible on the ground.



Fig. 215. Soli. View from the acropolis of the southern necropolis area. The holes visible in the ground are tombs, rifled before the arrival of the expedition.

sherds found in the trenches belong to Cypro-Archaic I—II periods, but they are very few in comparison with the dense heaps of Cypro-Hellenistic and Cypro-Roman sherds which, in certain localities, constituted almost the whole filling. The Cypro-Archaic sherds were found in the trenches on the top and the palace terrace exclusively, while no such pottery was found north of the road. Most likely the acropolis hill proper was first inhabited. Later on when the town grew larger the area between the hill and the sea was taken in for building activities. Certainly the old part of the town on the summit was many times repaired and rebuilt, which could be ascertained from the theatre. In ancient literature there are also records of destructions and rebuildings, to which I will return.

A few words may be said about the necropoleis of Soli. The tombs are spread over an enormous area, around almost the whole town. Wherever the rock is near the surface, caves have been excavated. Thousands of them have been opened by modern tomb-robbers, who in almost every case spoiled the pottery contents and the interior of the tombs. By studying the sherds found in these robbed tombs, however, there still exists a possibility dating them and thus ascribing different groups of tombs within the area

to various epochs. Thus, Mr. Markides examined some of the oldest tombs found around Soli and brought the contents to the museum. Most of the pottery from these tombs can be dated to the Cypro-Archaic II period. The tombs examined are situated on a low hill south-east of the acropolis. Cypro-Classical and Cypro-Hellenistic I tombs have been found west of the city on the other side of the river. Many of the most precious objects of various kinds are said to have been found in these tombs, and they seem to have been robbed almost to the last one. A beautiful, built tomb of Amathus type was destroyed, the ashlar taken away and used in the foundations of the road, as mentioned above. Close to the road a tomb was opened which contained a treasure of gold coins from the time of Alexander. The coins were all sold to a dealer in Lefka. The pottery from the tombs on this area points to the same period, 4th and 3rd Cent. B. C. This necropolis is of special interest as the temples described below have been constructed among the tombs of a burial-ground which was still in use. — The Cypro-Roman tombs are situated south and south-west of the acropolis on the slopes of the hills there. The necropolis, however, extends almost uninterrupted far away to the villages of Ambelikou and Lefka, the latter situated four miles from Soli. It will not be discussed here what troubles and difficulties, the protection of these vast areas against tomb-robbers means to the Government (Fig. 215).

NOTES ON SOME ANCIENT RECORDS OF SOLI

As the history of Soli, from the point of view of the ancient literature, has been the subject of repeated scientific investigations, only the most significant outlines of it will be indicated here. For a more detailed study on Soli reference is given to Engel's brilliant study on Cyprus, written in 1841, but which still remains up to date in most particulars.¹ Another compilation of the ancient records is given by Meursius², who has laid stress, however, on the Paphos problems of the island. More recent studies on the history of the island are found in Pauly-Wissowa, *Realencyklopädie der Altertumswissenschaft* in which the Cyprus articles are written by E. Oberhummer, who personally visited Cyprus and Soli. His article about Soli especially will prove to contain all the most important records as for the history and topography of the city, which are to be found in ancient literature.

Though not a town of a very great importance Soli is mentioned several times in ancient literature. According to Plutarch³, the earliest town, called Aipeia, was situated elsewhere. This town was founded on a wild mountain by Demophon, son of Theseus and brother of Akamas. The name Soli⁴ is connected with Solon's visit to Cyprus and Philocyprus, king of Aipeia. Solon advised the king to move the city down to the plain. Philocyprus did so and called the new settlement, after his friend, Soli. According to Strabo⁵ the city was founded by two Athenians, Phalerus who also is called the grandson of Erechteus, and Akamas. Soli, however, is mentioned already in the lists of cities of Esarhaddon (681—668 B. C.) and Asurbanipal (668—628 B. C.) where the name occurs as Si-il-lu.⁶

Soli seems always to have been one of the most Greek cities of the island and during the revolt against the Persians in 498 B. C. the king of Soli, Aristocyprus, son of Philocyprus, was

killed in the battle on the plain of Salamis. The city itself, however, sustained for five months the siege of the Persians, and was finally captured since all the city walls had been undermined.⁷ Most likely immediately after this event the palace of Vouni was built as a stronghold against the Greek elements in this part of the island. After this time, there are but few records of the town in the literature. A couple of kings are known, probably living in the fourth century.⁸ At the time of Alexander the Great, however, the role of Soli in the history of Cyprus is still important. Some names of the royal family can be connected with Alexander himself. As a matter of fact Soli at this time seems to have been the most important city of the island next after Salamis, which still preserved its supremacy since the glorious epoch of Euagoras. The Greek kings of Cyprus assisted Alexander actively during the siege of Tyre and some of them accompanied him on his way to the east. The kings of Salamis and Soli paid the expenses for the choruses when celebrating the capture of Tyre.⁹ The king of Soli was then called Pasicrates. His son, Nicocles, was one of the leaders of the Cypriote fleet which was used by Alexander on his expedition to Indus.¹⁰ Among other Cypriote generals who accompanied Alexander was Stasanor from Soli,¹¹ possibly a brother of the above mentioned Pasicrates.¹² He was later on made governor of Aria where he remained also after the death of Alexander.¹³ The last king of Soli was called Eunostos, who may have been of the same family as the others. He was married to Eirene, the daughter of Ptolemy Soter, and Oberhammer¹⁴ remarks that, as her mother was the famous hetair Taïs with whom Soter came into contact after the death of Alexander, their marriage cannot have taken place before the year 307 B. C. Most likely, therefore, Eunostos ought to have ruled his city independently even into the third century, while the other kingdoms of Cyprus, were incorporated with Egypt under a special governor more than ten years. During the Ptolemaic period little is known of Soli. Certainly a close contact between Soli and Ptolemaic Egypt was established already during the reign of Eunostos. This is but natural in consideration to the personal relationship between the ruling families. In reality, Eunostos, though formally independent, constituted one of the best fixed points for the diplomacy of Soter in Cyprus during this rather dangerous period. That this contact between Alexandria and the region of Soli was kept during the reign of Philadelphus, too, is confirmed by the inscription No. 740, found in Mersinaki, on which the names of Philadelphus and Arsinoe are mentioned. It will later on be argued that this break of the old tradition of royal independence of the city and the change of the cultural orientation towards the new powerful kingdom of Egypt, also meant a decided change in the history of art. This can be ascertained especially as regards the sculpture, concerning which the change is marked, not only by new stylistical aims, but also in the way that new materials were preferred.¹⁵

From the period of the later Ptolemies there are few records of Soli. The name is mentioned in the geographical lists of Ptolemy.¹⁶ Strabo, who travelled along the west coast of Cyprus about 20 B. C. gives the following particulars about the town¹⁷:

ἔτι Σόλοι πόλις, λιμένα ἔχουσα καὶ ποταμὸν καὶ ἱερὸν Ἀφροδίτης καὶ Ἰσίδος κτίσμα δ' ἐστὶ Φαλίφου καὶ Ἰαλίαντος Ἰθραίων οἳ δ' ἐγκαλοῦντες Σόλοι καλοῦνται ἐντεῦθεν ἢ Στασάνωρ τῶν Ἀλεξάνδρου ἱταίων ἀντὶ ἡγεμονίας ἡξιομένου ἰπέρκειται δ' ἐν μεσογαίᾳ Λιμενία πόλις

In spite of these very summary records the description will prove to be of a very great value when identifying the temples described on pages 416 ff. We have already written about Stasanor and his role in the Indian expedition of Alexander the great. Engel¹⁸ has thoroughly dealt with the question of Phalerus and Akamas as the founders of Soli (cf. above). For the first time in the literature we are confronted with some topographical particulars. The city had a harbour. The bay of Morphou is well sheltered against the east winds usually blowing during the winter.¹⁹ The situation of the harbour, still recognizable in the ground, has been described above. It remains uncertain whether the river, mentioned by Strabo, refers to the Kambos river, or to the Xeropotamus, east of the town. As the latter, however, runs at a distance of at least half a mile from the city area, I feel inclined to suppose, that the Kambos river should be the one which was present to Strabo's mind. The record of the temple of Aphrodite and Isis is extremely interesting as it is the first building which is quoted as to the Soli topography. It might be right to search for the situation of the temple in the vicinity of the river mentioned before. After the notes about Soli, Strabo mentions the town of Limenia which he places inland. Oberhummer,²⁰ however, has already pointed out that this must be a mistake of Strabo. The city mentioned was situated at the sea and must have possessed a harbour, which also the name of the town indicates. No doubt Oberhummer is right in locating the city on a small plain at the shore, 6 km. west of Soli, at present called Limnitis (hence Petra tou Limniti²¹). Limenia is recorded twice in the literature, in connexion with embarkation²² and disembarkation.²³ At modern Limnitis, some archaeological researches have been made²⁴ and quite a lot of antiquities of various kinds have been brought to light from time to time by the peasants, most of the objects dating from the Cypro-Roman period.

Limenia or Limne is also recorded in the *Acta Auxibii*²⁵ and there we obtain some very interesting descriptions of the topography, which for the following discussion will prove to be of such a great interest that the Acts may be cited here in the parts they refer to the monuments dealt with on the following pages. The Acts cannot have been written earlier than the fourth Century A. D. in view of the presence of certain names of localities,²⁶ but the author says that he follows an earlier MS. As a matter of fact, there are many particulars and details in the text indicating that the author was well acquainted with the local conditions and the topography of the place. The Acts are preserved in two MSS²⁷ and were edited in Latin not before the year 1560.²⁸ Auxibius is said to have lived in Soli for 50 years and as he met St. Mark, who travelled with St. Barnabas, about the year 52 A. D., in Limenia at his arrival in the island, he is supposed to have died in 102 or 103 A. D.²⁹ His tomb in Soli, still intact at the time of the conception of the Acts, was visited by many pilgrims.

Auxibius was a Roman who left the capital in order to avoid a marriage. Here follow his further adventures as they are described in the Acts:

§ 3

— — — Cum autem Roma solvissent, post dies aliquot Rhodum pervenere: indeque in mare, quod Pamphyliam alluit, trajicientes, Cyprum tenuerunt, et in pagum, qui Limne, id est Palus, dicitur, appulsi sunt, quarto ab Solorum urbe lapide, divina B. Auxibium, ad multarum salutem animarum ducente providentia. Nam egressus, Limnae moratus est, quo se ex navigatione recrearet qua valde jactatus, et fatigatus fuerat.

§ 5

Hic cum alter in alterum incidisset, Marcus Auxibium, Qua ex urbe oriundus esset, interrogavit. Auxibius vero, Ex magna, inquit, urbe Roma, propterea quod factus sim Christianus, huc veni. At Apostolus videns eum Christi teneri desiderio, fidelemque esse ac facundum, eundem probe instructum, et veritatem ex Dei verbo edoctum, descendens ad fontem baptizavit in nomine Patris et Filii et Spiritus sancti: baptizato manus imponens, Spiritum sanctum ei contulit: cumque eundem ordinasset Episcopum, et modum promulgandi Christi Evangelii edocuisset, ad Soliorum urbem hisce mandatis et verbis instructum misit. Siquidem ea civitas est idolorum cultui dedita, Deique nondum suscepit eloquia, sed in tenebris versatur idololatriae: quod tibi dico, id tu praesta. Nullus modo Christianum esse te noverit, sed ipsorum te superstitionem sectari simula: progressu vero temporis incipe occulte ipsis tamquam infantibus disserere, sermone eos tamquam lacte nutriens, donec perfecti facti, perfecti fiant alimenti participes. Cum haec atque his plura Auxibio dixisset Apostolus, eundem complexus in pace dimisit. Ac Marcus quidem navem nactus .Egyptiacam, ea conscensa Alexandriam navigatione pervenit: ubi Evangelistae functus munere, quae ad regnum Dei spectant edocuit.

CAPUT II

§ 6

S. AUXIBII EPISCOPATUS, PRAEDICATIO.

Ex Limnete autem profectus B. Auxibius percunctandoque iter faciens, Solos pervenit. Erat vero vicinum portis civitatis, qua parte occasum spectat, templum Jovis Dei nomen mentientis: in quo flamen dialis habitabat. Illac autem transeuntem B. Auxibium conspicatus Jovis sacerdos, tamquam peregrinum domi suae excepit sane perbenigne, eique mensam apposuit. Mansit igitur apud eum totam illam diem, postera vero, Unde, et caju gratia eo venisset, sciscitatus est sacrificulus. At Auxibius, Romanus sum, inquit, coactusque in Palaestinam vela facere, in Limnete excensionem feci: et percunctando edoctus gratam esse urbis hujus habitationem, huc me contuli, in eaque jucunde admodum habito. Verum si facis mecum misericordiam, maneam apud te, donec locum, ubi habitem, reperiam. Hic ille, Mane, inquit, sanus et incolumis. Mansit igitur eo loco qui Jovis nuncupatur, multo tempore, non significans se Christianum esse, quin potius fingens ipsorum se super-

stitionum sectari, itaque secum ipse disserens: Si enim diabolus transfiguratur se in Angelum lucis, ut eos, qui ipsi credunt, ad se pertrahat, et orationis blanditiis copiaque verborum a luce ad tenebras transferat, ut et ipsius ministri factitant; quanto magis debemus ipsi nos transfigurare in homines iisdem obnoxios affectibus, ut eos a potestate tenebrarum, et diaboli abducamus, et in admirabile lumen agnitionis Domini nostri Jesu Christi filii Dei transferamus?

§ 7

Haec secum ipse cogitans et faciens Dei famulus Auxibius praedicto in loco mansit. Paucis autem diebus evolutis, flaminem hisce verbis compellavit: Est quod dicam tibi, Frater. Age, dic, inquit ille. At Auxibius, Quid ist, ait, cur Deos colatis, qui lapides et ligna sunt? Os enim habentes non loquuntur, oculos habentes non vident, et aures habentes non audiunt, neque oblatum sibi sacrificium olfaciunt. Quem vero colunt Christiani, is demum, tu ab iis accepi, verus est Deus: atque, ut audio, virtutes multas operatus est. Haec sacerdos cum audisset, Auxibii verbis compunctus est, nec idolis sacrificabat amplius: sed deinceps a B. Auxibio instruebatur. Hac ratione ad multum tempus se gessit, urbem occulte ingrediens, et secreto docens, ac rursus recedens, et exiens extra civitatem, in praedicto Jovis loco manebat.

If we follow the text strictly, the following particulars can be gathered as to the topography of the places mentioned. Limne was situated at the fourth mile post from Soli, that makes 5.9 km. or almost exactly the distance from Soli to the present Limnitis. Hence, Auxibius went in the direction of the town, rested several times and arrived via (*transeuntem*) the temple of Jupiter at Soli. The temple was situated near the western gate of the city, and that it really was outside the town is clearly set out in § 7, where it is ascertained that Auxibius was the priest's guest, stayed outside the town and hence went into it and back again when teaching Christianity. The reference to sculptures in the temple will also prove to be of great interest as this temple will be identified with one of the excavated constructions. It may be noted that Barnabas embarks at Limenia and not in Soli, which was the chief town on the west coast, and Auxibius, too, has landed not in Soli but in Limenia. Oberhummer remarks that the town is mentioned as *ἀλιμενος*³⁰ and that the harbour of Soli seems gradually to have silted up. Possibly the harbour of Soli, mentioned by Strabo had to be replaced by that of Limenia. Under such conditions it is but natural that the city gradually began to lose its importance. As a matter of fact, there are very few places suitable for a harbour in the vicinity of Soli. The low, sandy coast to the north-east may have suffered from the same bad conditions as the shore just around the town; and on the rocky coast to the north-west, there are only two possible sites: Mersinaki and Limnitis. Mersinaki might have been used to some extent for smaller ships, but the narrow valley was certainly not big enough to receive a population which must be connected with a harbour. It seems, therefore, quite natural that the port of Limenia took over the marine trade of Soli when the harbour of that town could no longer be used. The advantages of the position of Soli were

based upon two very weighty presumptions: the vicinity of the copper mines and the vicinity of the sea and the harbour. If the latter began to silt up and the inhabitants were forced to search for a new harbour, the alterations must have meant a severe blow to the commercial life of the town. But this seems not to have taken place during the first century A. D. Galen, the great physician of the second century, who visited the copper mines of Soli in 166 A. D. has thoroughly described the seething life in the mines of Soli which were operated by the Imperial Government, the supervisor being appointed by the emperor himself.³¹ J. Walsh³² has come to the conclusions that the operation of these mines ceased about 400 A. D. when a series of severe misfortunes devastated the island for a long time. It seems hard to believe that the harbour of Soli was spoilt so soon after the visit of Strabo, that it could not have been used in the year 52 A. D. when Auxibius and the Apostle Mark found each other in Limenia. The only explanation, therefore, seems to be that the history of Auxibius, written in the present form, not earlier than the fourth century, was connected with the local circumstances which actually were present and known at the time of the author and not at the time of Auxibius. Evidently, the author was well acquainted with the town and its surroundings, and, as Soli, in his time, had no harbour, he made Auxibius land in Limenia, the harbour of which was known by the author as being used by the Solians, too. If we are right in these conclusions the quotation of the temple of Jupiter located to the vicinity of the western gate, consequently, may refer to a temple which was still in use, or, in any case, was still remembered when the *Acta Auxibii* were written, in the fourth century. Below, it will be demonstrated by finds and otherwise that there really existed a temple of this kind outside the town, close to the western gate as late as during the Constantine period.

Cesnola, on his visit to Soli³³, found on the slope of the acropolis hill a much injured inscription which may be mentioned here³⁴. It is now stored in the Cyprus Museum, but in 1888 Hogarth saw the slab as threshold in a store in Karavostasi. It is a votary inscription who tells that Apollonius consecrated an enclosure and a monument. It may be noted that Hogarth has corrected Cesnola's reading of the inscription so that the word *Παυλάρι-ετοι*³⁵ has been eliminated. The chief interest with this inscription is that it is dated to the time of proconsul Paulus who, no doubt, is the Sergius Paulus mentioned in the Acts of Apostles in connexion with St. Paul's first visit to Cyprus in 45 A. D.³⁶

During the Christian era Soli is recorded several times. The above mentioned Auxibius was the first bishop of the town. After him came Auxibius II³⁷ and Themistagoras, the brother of Auxibius I. At some of the early Christian councils Soli was repeatedly represented by bishops. At the end of the thirteenth century the capital of the bishopric was changed to the new capital of the island, Nicosia, because in 1340 we know of Leontius of Solia, bishop of Nicosia.³⁸ Shortly after this, the town itself must have ceased to exist. Lusignan mentions the place only as Casal Solia.³⁹

Most likely, however, the importance of the city had gone long before the Mediaeval Age. The real cause of this decadence may have been the above-mentioned silting up of the harbour and the coast and, furthermore, that the copper mines no more were operated.

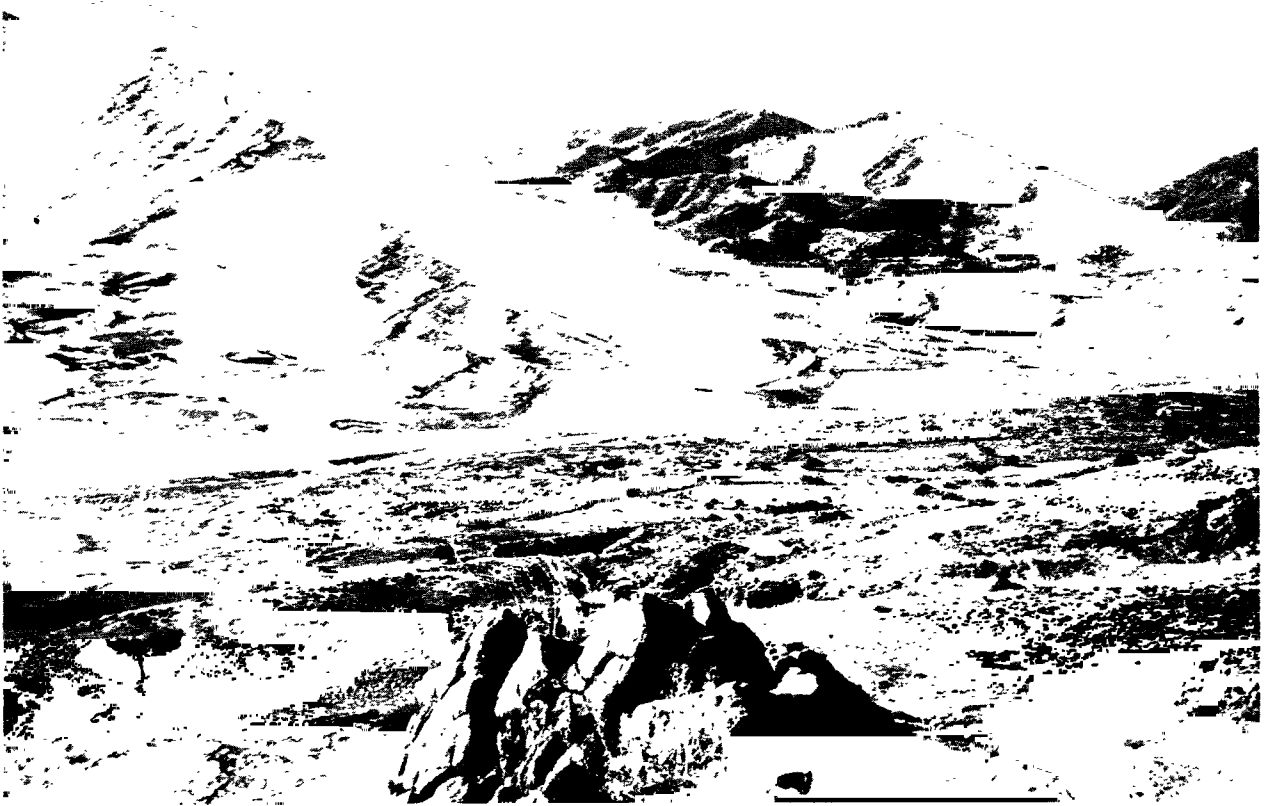

Fig. 216. View of the valley of the Kambos river.

The view that Soli fell into ruins comparatively early is confirmed by the fact that the remnants never called for any special attention of later travellers. R. Pockocke⁴⁰ visited the ruins and his description of the place may be mentioned, as he takes up the problem of the temple of Isis and Aphrodite recorded by Strabo. On the acropolis slope, Pockocke found some remains of a rather important building above earth, which he, consequently, identifies with the only antique building he knew of, the temple mentioned by Strabo. It is needless to say that nothing exists which makes his suggestion acceptable. To judge from his description of the monument, it may have been a gate or a portico. Whether this construction belongs to the same one, which Cesnola mentions, remains uncertain⁴¹. These foundations consisted of a circular building constructed of huge blocks of limestone. Below the building, a cave was situated. In the area of this ruin, Cesnola found the Paulus-inscription (cf. above) and a female marble statuette. As no traces of the circular building can now be found within the area of the ancient city it is impossible to assign Cesnola's ruins to any certain part of it. The ruins had already disappeared when Hogarth visited the site in 1888.⁴²

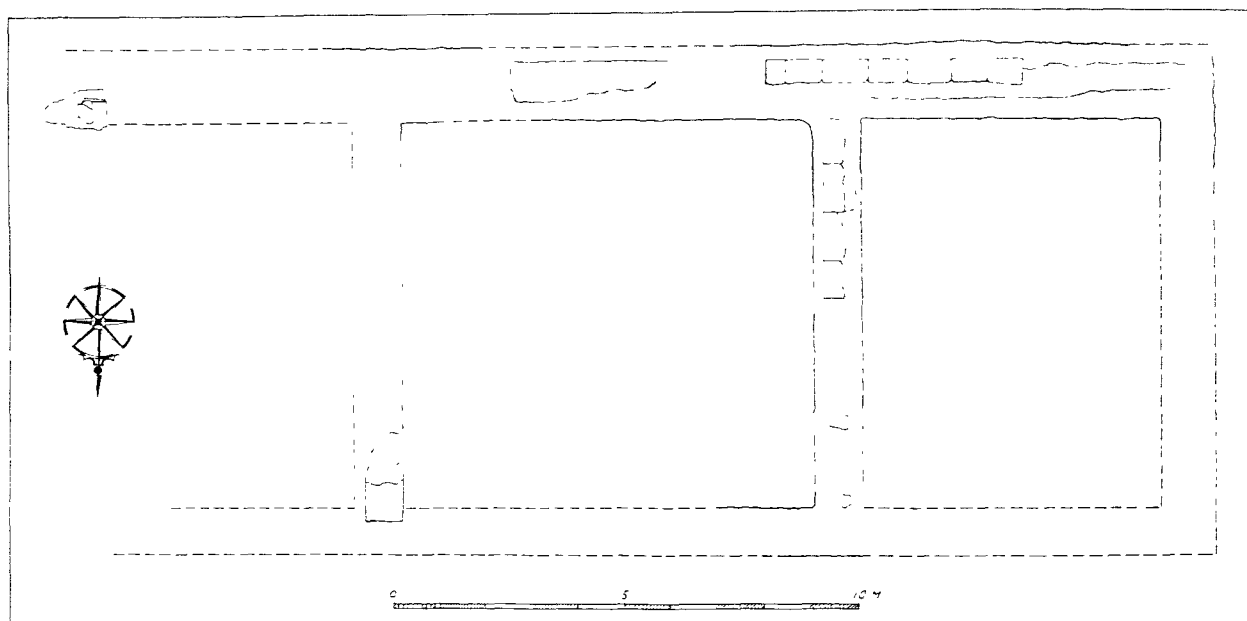

Fig. 217. Soli. Plan of the temple on the acropolis.

The Acropolis

The temple on the summit was very much destroyed. Only minor parts of two walls composed of lying ashlar, were preserved (Figs. 217, 218). The extent of the walls could, however, be traced by means of the depressions in the rock in which the walls had been placed. The gypsum bed for the ashlar, too, was partly preserved. In spite of these indications, however, large portions of the temple had to be reconstructed and it must be admitted that the reconstruction is very conjectural. — The most natural way of interpreting the architectural remnants is to reconstruct the building as a Greek *ante* temple with the front to the E. In such case the length of the temple would be determined to about 24 m. as the west wall is ascertained and probably also the length of the right *ante*. The width of the building is definitely determined to about 10.0 m. Though the whole north wall is missing the depression in the rock indicates its previous position. In the same way two walls are indicated, running between the northern and southern walls, thus dividing the construction in three rooms. The central one is larger in size than the western. The eastern room is situated between the two walls which are supposed to be the *ante* construction of the temple.

It has been pointed out in the previous discussion that this reconstruction is very conjectural and one has to reckon with other possibilities, too. As the north wall has vanished completely, one cannot ascertain whether it was provided with entrances facing the open area of the acropolis hill. The plan of the building would in such case resemble the characteristic Cypriote temple type which consists of three cellae at the side of each other all of them opening on to a court. Like in the temples at Vouni (cf. p. 85) and the Serapis temple E at Cholades (p. 488) and others the central cella would be larger in size.



Fig. 218. Soli. Acropolis. Preserved foundation walls of the temple.

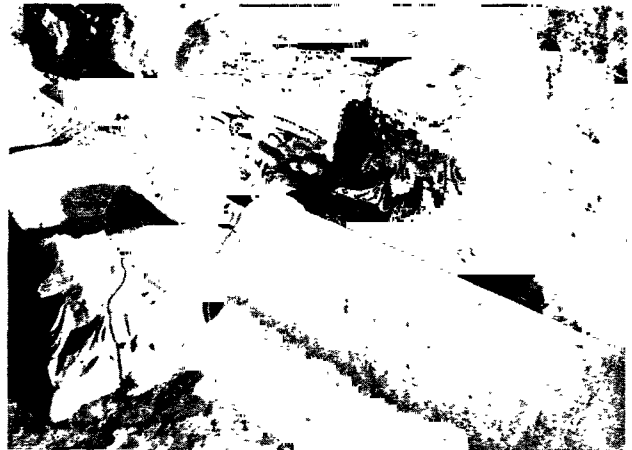

Fig. 219. Soli. Monastiraki. Column and capitals *in situ*.

The entrance up to the area on the summit was discovered on the north side, indicated by some remnants of a rectangular building constructed of porous ashlar. Only few of them were preserved but the extent of the building was indicated by the bed of gypsum on which the walls rested. Possibly there was a stair following the slope up to the summit. Practically no soil, except the surface layer covered the architectural remains, but some finds were made among the stones. They are listed on p. 414 together with other finds from the upper portions of the acropolis hill.

Further to the north, there is a wide terrace almost horizontal, which terminates roughly along the 50-metre line on the field map. North of the *temenos* gate this terrace was crossed by a trench about 100 m. long. A great many walls, all belonging to the same rectilinear building system were cleared in the trench, some of them being preserved to considerable height. The suggestion may be right that we here have traced the royal palace. The position of the palace in Soli would in such case, correspond very well to that at Vouni, where the palace was constructed on the first wide terrace below the *temenos* of Athena on the top. As the pottery found in this trench shows, the palace of Soli must have been of contemporary, or later date than the palace of Vouni. East of this palace building the theatre is situated with its semicircular back wall not far from the city-wall on this side. Below the terrace with these two monumental buildings the ground slopes rather steeply towards the sea. A great many walls and ruins are visible on the surface and the innumerable building stones and potsherds spread out over the whole surface show that the building activity once was concentrated to this part of the city.

FINDS

During the course of the various excavations described above some finds were made. They are listed below, and references to their find places are made by indicating the

terrace on which they were found. The acropolis is called Ter. I; the entrance up to the acropolis Ter. II; and the area with the palace, Ter. III and IV. The finds of the two larger excavations, the theatre and the temples at Cholades, are extracted and described in connexion with those excavations on pp. 494 and 574. The finds from the theatre are numbered 1, etc.; those from the sites above from 101, etc.; and those from Cholades from 301.

OBJECT REGISTER

- | | |
|---|--|
| <p>101. Bronze ring; circular section. Diam. 1.4. Ter. I.</p> <p>102. Iron dagger; two edges; leaf-shaped; point broken. Length 21.0. Ter. I.</p> <p>103. Body of terracotta rider. Snow-man technique. Height 6.2. Ter. I.</p> <p>104. Spindle-whorl of stone; conical; pierced through centre; incised circle on base. Diam. 3.1. Ter. II.</p> <p>105. Fragment of terracotta horse; "snow-man" technique. Length 8.0. Ter. II.</p> <p>106. Fragment of terracotta horse; back part preserved; "snow-man" technique. Length 8.0. Ter. II.</p> <p>107. Moulded terracotta lamp; bottom missing; biconical shape; radiating, incised lines on upper side; large, central hole with flat rim; horizontal nozzle; sculptured lion's head as side-knob. Length 7.2. Ter. II.</p> <p>108. Bronze fibula; arched bow with rich mouldings; thin catch; coil and pin missing. Length 5.2. Ter. II.</p> <p>109. Bronze fibula; arched, somewhat angular moulded bow with three beads; coil and pin missing. Length 3.5. Ter. II.</p> <p>110. Leaf-shaped arrow-head of bronze; socket and mid-rib; two edges. Length 5.9. Ter. II.</p> <p>111. Nail of lead; square section; head missing. Length 11.0. Ter. II.</p> <p>112. Miniature jar of lead; deformed; flat, raised base; bulging sides; wide rim; hole just below the rim. Height 2.2. Ter. II.</p> | <p>113. Arrow-head of bronze; three edges extending over the socket. Length 3.0. Ter. III.</p> <p>114. Fragment of bronze fibula; top decoration with knob and disc-shaped collar. Height 4.0. Ter. III.</p> <p>115. Bronze nail; irregular section; flattened point; small head. Length 5.3. Ter. III.</p> <p>116. Fragment of terracotta horse. Height 8.0. Ter. III.</p> <p>117. Head of terracotta lion; small face with incised eyes and eyebrows. Height 5.0. Ter. III.</p> <p>118. Mat Black terracotta lamp; raised base; biconical body; moulded central hole; horizontal nozzle (partly broken); side-knob. Length 8.2. Ter. III.</p> <p>119. Loom-weight of terracotta; pyramid-shaped; pierced at top. Height 6.0. Ter. III.</p> <p>120. Loom-weight, as No. 119; but with truncated pyramid-shape. Height 6.5. Ter. III.</p> <p>121. Loom-weight of terracotta; flat, circular; pierced at the edge. Diam. 8.1. Ter. III.</p> <p>122. Loom-weight of terracotta; circular; pierced at the edge. Diam. 6.0. Ter. IV.</p> <p>123. Loom-weight, as No. 121. Diam. 6.0. Ter. IV.</p> <p>124. Fragment of terracotta lamp; black lustrous; flat, raised base; moulded edge around central hole; thick horizontal nozzle. Only nozzle with part of body preserved. Length 9.0. Ter. IV.</p> <p>125. Bronze nail; bent; broken. Length 7.3. Ter. IV.</p> <p>126. Bronze arrow-head; three edges extending along the whole socket. Length 3.5. Ter. IV.</p> |
|---|--|

CLASSIFICATION OF FINDS (PL. CLXXX)

I r o n .

Dagger.

The dagger (No. 102) is leaf-shaped and has two edges.

B r o n z e .

Arrow-head.

These are of two types. 1. leaf-shaped, with midrib socket, and two edges (No. 110).
2. Three-sided with three edges extended over the whole socket (Nos. 113, 126).

Fibula.

The fibulae represent three types. Arched, angular, somewhat moulded bow with coil and pin (No. 109). 2. Similar but with rich mouldings on the bow which is not angular (No. 108). 3. The shape of the fibula No. 114, of which only a fragment is preserved, is probably that with a bow the top of which is marked by a knob.

Ring.

No. 101 is circular in section.

Nail.

The nails Nos. 115 and 125 are rather irregular in section and provided with comparatively small heads.

L e a d.

Vase.

No. 112 may be an amulet or box for the same in shape of a small jar.

Nail.

No. 111 is irregular in shape. The head is missing.

T e r r a c o t t a.

Loom-weight.

Two shapes are distinguished 1. Flat, circular, pierced near the edge (Nos. 121, 122, 123). 2. Pyramid-shaped, pierced at top (Nos. 119, 120).

Lamp.

Two types are represented: 1. wheel-made, flat, raised base; rounded side; large, central hole, with moulded edge; thick, horizontal nozzle; side-knob (Nos. 118, 124). 2. moulded; biconical shape; radiating incised lines on upper side; horizontal nozzle (No. 107).

Statuette.

The statuettes are all very fragmentary. 1. Nos. 102, 105, 106, 116, all constitute fragments of terracotta horses while, 2. No 117 is a head of a terracotta lion.

S t o n e.

Spindle-whorl.

No. 104 is conical in shape; pierced through centre and provided with an incised circle on the base.

A. W.

The temples at Cholades

ARCHITECTURE (Plan XXXIV)

MATERIAL AND CONSTRUCTION

All the walls within the area excavated are constructed of rubble, most of which were taken from the river-bed below the site. Some of the blocks had been roughly cut in order to fit into the wall. The rubble blocks are of various kind: some are white in colour and very hard, consisting of hard limestone. This kind of stone is not to be found in the local rock of Soli. Most likely the blocks have been brought from elsewhere by the river. These white limestone blocks are but rarely rounded, which, however, is the case with the heavy, black stones which most frequently occur in the walls. These are of a kind of stone very similar to basalt and are also to be found in the river-bed. They are very well rounded off, usually oval in shape. In the walls, a great many ashlar blocks were found but they are all to be explained as coming from other buildings and re-used here. Their place in the walls was accidental, and as could be observed, they were never used according to a definite principle in order to strengthen a certain part of the wall, or something similar. At some entrances and stairs, the ashlar were used as thresholds and steps, and also in the altars. Sometimes traces of removed ashlar on the foundations of the stairs were noted which seems to indicate that ashlar blocks had been used more frequently than the preserved architectural remnants could show. The ashlar blocks consisted of a hard, white limestone which contained petrified shells. The occasional finds of statues, or pieces of sculptures in the walls are explained, too, in the same way as the ashlar blocks. They are fragments of old statues, smashed and damaged and now simply re-used as building-stone. In some of the walls and altars fragments of roofing-tiles and bricks were used. These walls on other grounds could all be ascribed to a comparatively late period, e. g. Walls 38—41 and Altar 147.

The mortar used for keeping the stones together in the walls is of two different kinds: the usual one used in most of the walls consists of white or bluish-grey plaster which sometimes becomes very hard in consistency. The same plaster seems to have been used for the revetment of those parts of the walls which were visible above ground. The revetment varies as to its consistency; sometimes it is very carefully applied with a smoothed surface, in some cases decorated with paintings as on Walls 20, 23, 24 A and B, 88, 109—111, etc. On other walls the plaster revetment was of the same hard consistency, but not so carefully smoothed as on Walls 67—69. The plaster revetment never extended below the floor-level. Sometimes, as the floor could be determined in no other way, these clearly marked edges of the plaster were extremely important for the analysis of the architecture. Often, especially on walls which on other grounds could be determined as comparatively late, the plaster revetment was very soft and had almost entirely fallen off the walls, or did so a short time after uncovering them. This holds good for Walls 123 and 124. Another



Fig. 220. Soli. Cholades with excavated temples.



Fig. 221. Soli. View of the excavations.

somewhat harder plaster revetment was found on the inside of the walls enclosing Room XVI—XVIII. This was of the same kind as was found on the southern face of Walls 19 and 20.

The second kind of mortar was entirely used for holding the stones together. It was rather like modern cement, grey in colour and very hard. In comparison with the concrete described below, it was fine grained and did not contain pebbles, though the consistency otherwise was similar. Curiously enough this peculiar kind of mortar which was easily distinguished from all the others was found only in a few walls: Nos. 21 (a small part just above the filled-up tomb below the wall), 24 B, 38—40. Possibly the suggestion may be right that the walls mentioned were built or repaired contemporarily.

The water-conduit, No. 167, and the cisterns, Nos. 168—170, were constructed of a core of small stones on which a concrete was laid out. The concrete consisted of grey mortar mixed with pebbles. It was very hard and solid, and in consequence of this extremely well preserved from the beginning, west of Wall 86, to a few metres above Cistern 169. The conduit had been covered with flat slabs of the local soft rock. The slabs partly remained *in situ*.

Wood seems to have been used on various occasions. Most likely all the doors were of wood. The same material was also used for flooring, at least at one occasion: as is shown by Sections XIII and XIV there was a floor of thick, wooden beams along Wall 89. Walls 101 and 102 are substructures for the same floor. The wood proper, naturally, had decayed, but the gypsum by means of which the beams were fixed together was preserved and showed their exact places.

As to the construction of the walls it must be said that in general they were very loosely fixed together. Very often the walls were only distinguished from the surrounding loose stones by means of the most careful excavation. This holds good especially concerning the walls which had lost their plaster revetment, or which never had one. Mainly the walls were built up of the rubble which had been laid in comparatively level courses. It is but natural that the construction of the walls changed in accordance with their task: walls built for keeping up a terrace, or as a facing against the vertically cut rock edge thus have only one side level and carefully laid. The foundation walls usually are wider than the upper walls; other walls are still narrower if they have nothing heavy to support. As to the construction the following two main types of rubble walls are distinguished:

A. The usual walls with more or less even courses of rubble blocks running through the whole wall without any break. In these walls the mortar or plaster is found equally in the wall. As a rule, the stones of these walls are very well fixed together.

B. The second type of walls are constructed fundamentally in an other way. At equal distances there are very solid, square pillars, built from the bottom to the top of the wall, which are constructed of rubble and plenty of hard, white plaster. These pillars occupy the whole width of the walls and constitute a kind of very characteristic skeleton for the walls. They are never bonded with the portions of the wall which run between the pillars. Those are, as a rule, usually very loosely kept together with little, or, sometimes without

any mortar at all. The whole strength of the wall depends entirely on the solid pillars which, as the preserved remains showed, fulfilled their function extremely well. This type of walls occurs both in cases where the wall was founded on the solid rock and when it rested on a layer of earth.

The construction of the altars are similar to that of the walls. Only in Rooms XXXIV and XXXV the altars were built of carefully hewn ashlar blocks of the same kind of stone as the ashlars in thresholds and stairs of the same rooms. Other altars were constructed of small rubble, loosely kept together by gypsum or plaster. The core of the altars consisted of loose blocks. The outside of the altars were probably always covered by a revetment of plaster. In some cases especially on Altar 146 the plaster was smeared on the surface in several layers which were easily distinguished from each other. Usually the altars were built on a base of solid rock which extended a little higher than the surrounding floor levelled in the rock. The construction of Altar 149 remains uncertain. Possibly it consisted of a stone table.

The floors were always difficult to define on account of their vague appearance. In cases where the rock had been levelled for the floor it could easily be followed. Cavities and sloping portions were often filled up etc., but usually there were no real floors of concrete, stone slabs or similar substantial materials. The floors many times were simply marked by a thin layer of plaster or stamped earth. Other floors were recognized as a faint change of colour in the earth. In some cases it was even absolutely impossible to find any traces of a floor which, however, for other reasons must have existed at a certain level. This made the excavation extremely difficult, and always one ought to be chary of using the evidence. Of special interest is the flooring of the courtyard, Room XXIX, where masses of *chavara* was spread out as a floor. This was so hard packed that it had become very similar to the natural rock. Only by means of excavations, and the pottery found mixed with the stuff, could it be ascertained that it was artificial. The possibility exists that wood often was used for flooring though it could be ascertained only once (above Walls 101 and 102). A study of the sections described below will give the best idea of the various floors.

WALL PAINTING

Several walls had been decorated with mural paintings. The paint was applied on the stucco-revetment, which for that purpose was carefully smoothed. The paintings were found on Walls 11, 20, 23, 24 B, in Rooms XLV and XLVI. Owing to the destruction of the walls, only small parts of the paintings were preserved *in situ* and most of them were found on fragments of stucco, fallen on the floor close to the walls. Only in Room X the paintings were more completely preserved so that the entire pattern could be studied. All the other walls, however, seem to have been decorated in the same way: vertical and horizontal lines in red, blue or black and green, forming a pattern of large squares. The lines are drawn with great precision, strictly straight. They are about 1.0 cm. wide. In Room XLVI fragments with wide, red bands, too, were found.

SOLI

The temples at Cholades

Architectural plan

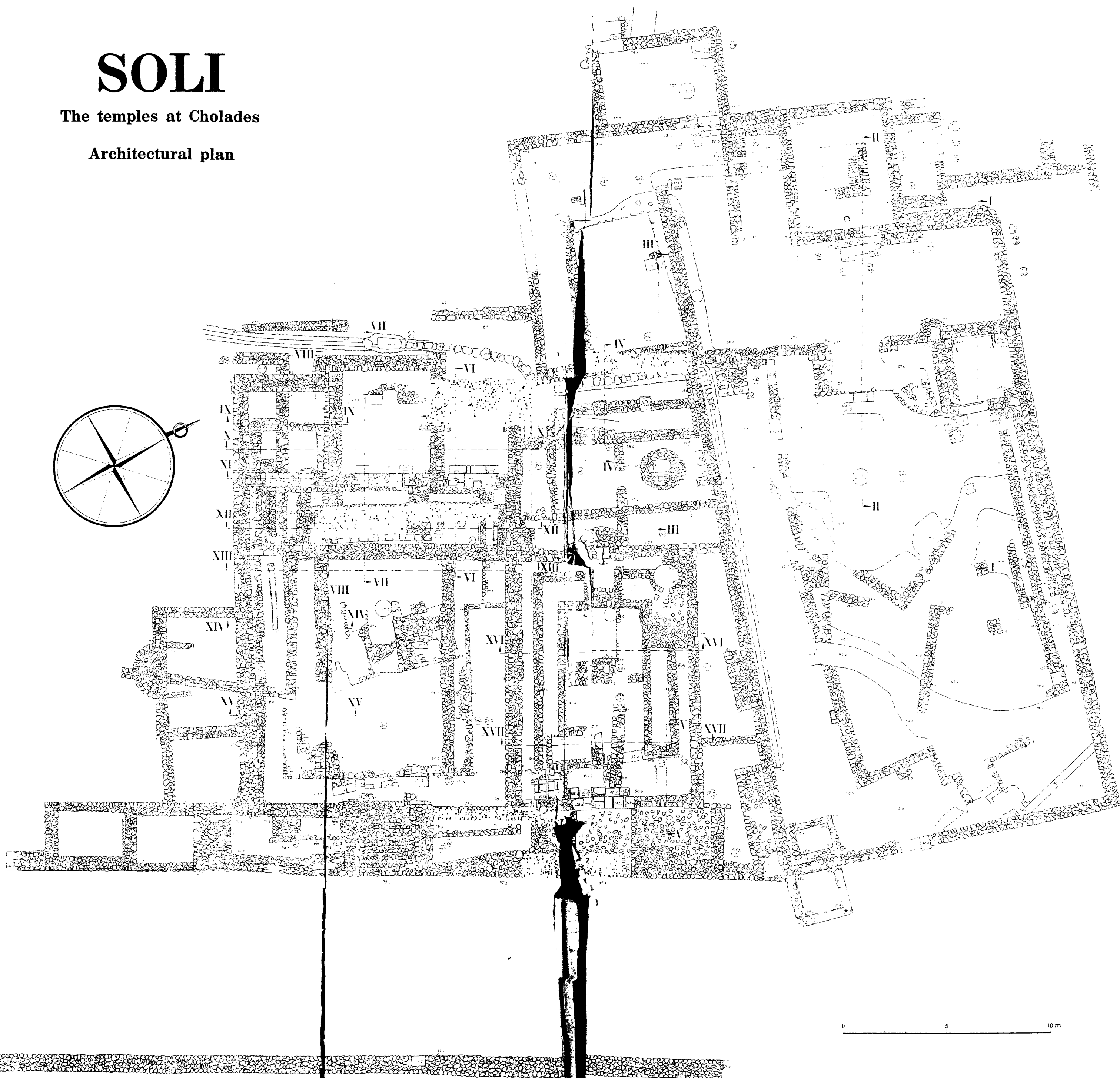
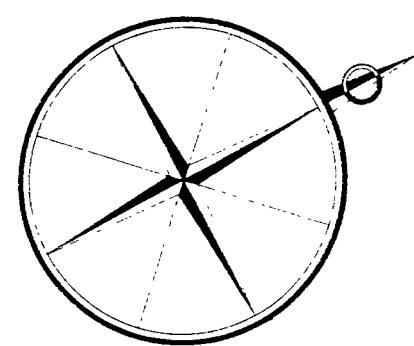

0 5 10 m

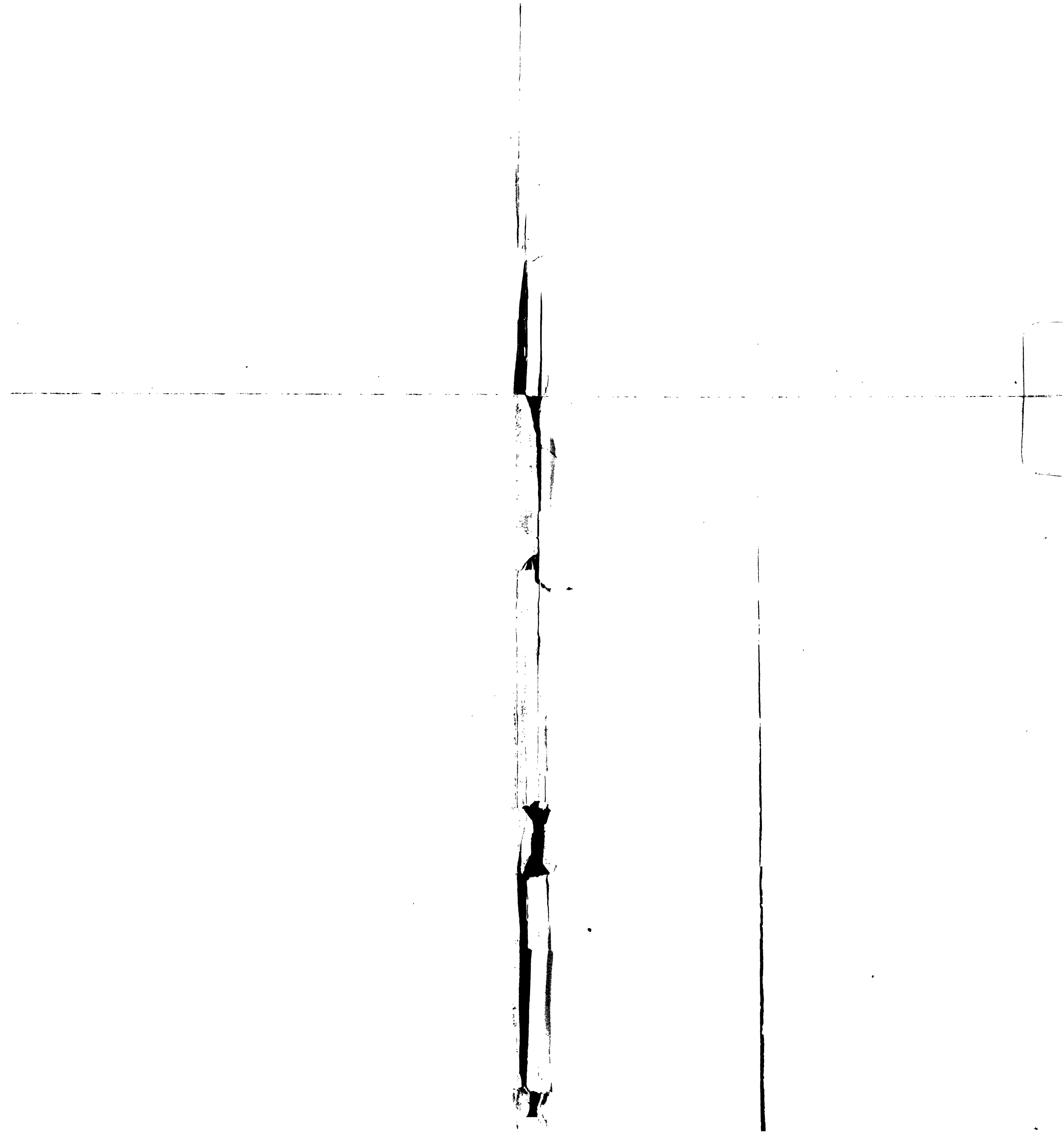



Fig. 222. Soli. *Cella*, Room V, of Temples A and B, from the East.

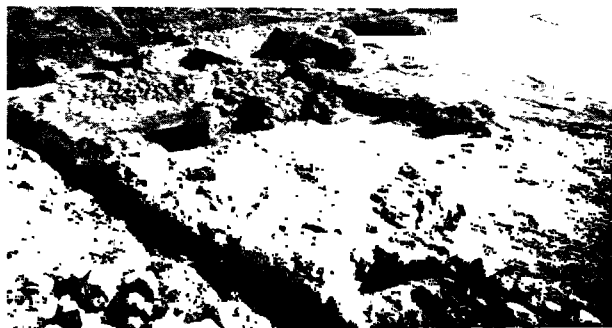

Fig. 223. Soli. *Cella*, Room V, of Temples A and B, from the West.

and in the middle of the walls there are very solid pillars built of hard gypsum mortar. These pillars give the walls a substantial character. The walls are founded on the rock and sunk in trenches excavated in the rock. Wall 5, which is preserved to a height of 1.0 m. is covered by a hard gypsum revetment on both faces. A similar revetment is also preserved on Walls 6 and 8, but only on the interior faces towards Room V; the heights of these walls diminish to the E. Through Wall 7 there was a door, of which only a part of the threshold is preserved. The walls are not bonded with walls other than Wall 9 (cf. below), where some bonding stones are to be seen on the S. face. The doorway was made in the middle of the wall. Only a fragment of the threshold is now preserved at the N. side of the doorway. This consists of a flat stone in which is a square pivot hole. (Figs. 222 and 223).

Wall 9.

Width: 0.52. m. Height: 0.20 m.

In the middle of the S. face of Wall 6, there is evidence that the wall once was bonded with another wall extending to the S. W. Here some bonding stones project out of the face-line breaking the gypsum revetment on the face. In line with these bonding stones a piece of wall is noticed, partly built over by Wall 45. This wall consists of a single layer of dark rubble lying on the rock. Apparently the rest of the wall had been destroyed intentionally in connexion with later alterations. On the same axis with this piece of wall and the bonding stones in Wall 6, a trench is excavated in the rock to a depth of approx. 0.75 m. The trench makes an angle to the E. straight down to Wall 10 B. Evidently the trench was made for a wall. Under such circumstances this wall must be connected with the piece of wall to the N. of Wall 45. It was possibly, too, connected with, or even bonded to Wall 10 B (cf. below) or some other wall in the same position. (Fig. 224).

Wall 10.

Width: 0.60 m. Height: 2.00 m.

This wall is built in two parts as facings for the rock in Rooms III—IV. It consists of two parts, slightly diverging from each other. The lower part (10 A) was founded on a layer of *chavara*, and is built of dark, rounded rubble of ordinary size, mixed with white limestone, without mortar. The wall is bonded to Wall 54. As the angle was badly destroyed, it could



Fig. 224. Soli. Room IX, with preserved fragments of Wall 9.



Fig. 225. Soli. Stair 159 and Altar 146.

not be ascertained if it is bonded to Wall 51, but probably that was the case, as no cut between the walls could be found. Possibly the wall once was higher and then connected with Wall 9. A similar facing wall, however, must have been necessary for the rock edge. The upper part (10B) is of a similar construction, but the stones are here rather loosely fixed together. The upper part is not bonded with other walls. (Fig. 261).

Wall 11.

Width: 0.50 m. Height: 1.25 m.

The wall makes an angle with the preceding wall and is a facing for the soft rock to the W. of the wall. It is of a rather solid construction and built of irregular rubble mixed with white limestone, held together with hard, white mortar. The E. end of the wall is strengthened by a short buttress containing larger rubble. Another low, supporting wall is built in front of the wall to the N. of the Stair 161. The face was once covered with a gypsum revetment which has now partly disappeared. Behind the subsequently built Stair 161, however, this revetment was found well preserved. The wall is not bonded with the adjoining walls, and the cut between this wall and Wall 10 B is very well marked. There must have been a doorway through this wall above the stair, but of this nothing is preserved. Its threshold level should be at 130.0, which is the floor-level of Room XVI. (Fig. 262).

Wall 12.

Width: 0.45 m. Height: 0.30 m.

This is exactly of the same construction as the preceding wall. As the difference of rock-level above and below the wall is less than at Wall 11, it is now preserved to an insignificant height. Here, too, a short buttress is noticed at the S. end of the wall. The N. part of the wall seems to have been bonded to a wall which once extended towards the N.W. This wall (12 B), however, had been removed entirely, during later alterations. Between the Walls 11 and 12 A, there is a doorway 2.20 m. wide. It seems impossible to state whether it was closed by a door or not. No traces of a threshold, however, are to be seen in the rock floor. (Figs. 225 and 260).



Fig. 226. Soli. Room XX, with row of column-bases.



Fig. 227. Soli. South-east corner of the courtyard, Room II.

Wall 13.

Width: 0.80 m. Height: 0.60 m.

It is a short facing wall for the rock floor of Room VII. This gives the character of the wall. The exterior face is rather solidly built with dark rubbles mixed with white limestones and kept together by hard gypsum mortar. The interior face, which abuts against the rock edge, is very loosely fixed together. The wall forms a right angle and faces the rock as far as Altar 146. (Fig. 225).

Wall 14.

Width: 0.65 m. Height: 0.40 m.

This wall consists of dark rubble mixed with small white limestone without mortar. The wall is severely damaged, and only preserved where the wall runs in the lower parts, or depressions of the rock. Apparently the higher parts of the wall were levelled by subsequent alterations, or by raising the site to the level of the rock. The E. part of the wall is comparatively well preserved, with the whole width of the wall still visible. The W. parts, on the contrary, are more uncertain. Here only rows of stones are still *in situ* in a line with the S. face of the wall. The wall disappears to the W. without any precise line. Probably it once was prolonged up to Wall 11. (Fig. 227).

Wall 15.

Width: 0.40 m. Height: 0.30 m.

This wall is of the same construction as the preceding, with which it is bonded. At the middle, the wall is strengthened by a buttress. (Fig. 227).

Wall 16.

Width: 0.35 m. Height: 0.20 m.

It is of the same construction as Wall 15, with which it is bonded. It is bonded to Wall 17 also.



Fig. 228. Soli. Wall 18 with superimposed Wall 27.



Fig. 229. Soli. Stair 157 built over a rock-tomb.

Wall 17.

Width: 0.45 m. Height: 0.25 m.

This wall is built as a facing for the crumbling rock and consists of rounded rubble mixed with fragments of lime-ashlar, the latter being placed at the exterior face. The wall is interrupted at the middle by the remains of Staircase 157 (cf. below), and seems once to have been prolonged for an uncertain distance.

Wall 18.

Width: 0.65 m. Height: 0.35 m.

This wall is of the same construction as Wall 14 to which it is parallel. It is founded on the rock, and built as a revetment against the rock, which to the N. is at a higher level. At the E. end, an exterior angle is found with a short fragment of another wall, possibly parallel to the Wall 15. The wall has partly been built over by Walls 27 and 28. Most probably the wall once was prolonged to the N. for an uncertain distance. This part was probably removed when the walls mentioned were built. The prolonged line of the wall would pass just over the joint of the Walls 12 and 23. (Fig. 228).

Wall 19.

Width: 0.60 m. Height: 1.25 m.

This wall is built on the solid rock, of dark rounded rubble and white limestone. Mortar does not seem to have been used for fixing the stones. The E. face, however, which is carefully built, is covered by a thick gypsum revetment, well preserved, especially on the lower parts. The W. face is very roughly built without a straight face. Probably this face was not intended to be seen, but covered with earth (cf. the back of Walls 88, 68, and 70). The

wall is built in line with Wall 7 but it is not bonded with it. In front of these walls and partly covering their faces, there is a low piece of wall, which must be subsequent as the gypsum revetment of Wall 19 extends in behind the wall. The meaning of this wall, which is of the same character as Wall 19 seems to be uncertain. Possibly it can be connected with subsequent alterations to Staircase 158, up to Room V.

Wall 20.

Width: 0.65 m. Height: 1.70 m.

This wall constitutes a right angle with Wall 19 and is partly built as a revetment for the rock to the N. of the wall. It is of the same character as the preceding wall, but contains scanty remains of gypsum mortar. It has at the ends and at certain intervals along the wall, six square solidly built pillars containing fragments of ashlar held together with hard gypsum mortar. Only the south face is covered by a revetment, which extends down to the rock, even behind Walls 25 and 26. Near the E. end of Wall 26, some large fragments of statues were used as building-stones. Just a little E. of Wall 25, there is a cut in the wall, which, W. of it has a more solid character than to the E. This E. part had its S. face covered by painted stucco, partly preserved behind Wall 26 (cf. below). The wall is bonded to Walls 19 and 21. A short projection on one of the supporting gypsum pillars just on the axis of Wall 23 seems to indicate that that wall was intended to be bonded to Wall 20, though, because of the pillar, there exists a cut between the walls. The Walls 25 and 26 were evidently added to the wall, covering its revetment. (Figs. 225 and 226).

Wall 21.

Width: 0.55 m. Height: 0.50 m.

The wall, which is bonded to Wall 20 is partly of the same character as the latter. It shows, however, certain dissimilarities probably owing to difficulties in bridging over a demolished rock-tomb below the middle of the wall. Just above this tomb, the wall is carelessly built and has very scanty remains of mortar. The N. end of the wall is more solidly built, and here two kinds of mortar are used: the usual kind of gypsum, to be seen especially in the two supporting pillars, and a second kind, dark in colour, and more like cement (cf. also Walls 38—40 and 24 where the same kind of mortar is used). Just S. of the rock-tomb, a door through the wall is noticed with one threshold stone preserved *in situ*. After an interval of about 1.50 m., there is a second door through the wall beside the first one. The piece of wall between the doors is built, with the second, dark kind of mortar. The wall runs to the S. between the two basins at the angle between this and next wall to which it is bonded. The lower basin is bonded to these walls but not with the higher one. (Fig. 229).

Wall 22.

Width: 0.60 m. Height: 2.00 m.

This wall is built as a revetment for the rock to the N. of the wall. The wall is, as far as could be stated, for the whole of its extent, founded on the rock and built of rubble of ordinary size held together with white gypsum mortar. In some parts, however, ashlar are used

for strengthening the wall. That is the case, close to the two basins at the E. end of the wall. The lower basin is bonded to the wall with three large ashlar. Near the middle of the wall, there is a vertical cut through the wall. As the building technique is of the same character on both sides of this cut, it seems to be of little importance. Another cut, on the contrary, is to be found 6.60 m. E. of the angle between Walls 52 and 22. Here the differences on both sides of the cut are evident. W. of it, the wall is very solidly built of larger rubble held together with hard gypsum mortar. The Substructure Wall No. 56 is rather rough and built without mortar; it is not founded on the rock just below the conduit as the rest of the wall, but on a layer of *chavara*. Higher up, however, the wall has a smooth face covered with a gypsum facing at about the same level as the water-conduit, which passes through the wall in its W. end (cf. Fig. 237). Close to the cut mentioned, this W. part of the wall is strengthened by large ashlar, solidly held together with gypsum mortar. Only on the W. part, the wall is preserved to a higher level than the conduit, which follows the wall along its N. side. The conduit passes through the wall, and must have been built at the same time as the wall itself. Above the conduit the wall is clearly bonded with Wall 52. That is however, not the case with the Substructure Wall No. 56, which below the conduit abuts against Wall 51. Other adjoining walls, with the exception of Wall 21, abut, too, against Wall 22.

At level 116.8, there was a doorway through the wall into Room XXIII, the original width of which cannot be stated. To the S. of the wall, a flat stone was found in a horizontal position. This might have been part of the threshold, or a step for making the passage from Room XIX to Room XXIII more convenient. (Fig. 262).

Wall 23.

Width: 0.60 m. Height: 1.60 m.

It is solidly built on the rock with rubble of ordinary size. White gypsum mortar is used for fixing the stones together. The wall begins at one of the gypsum pillars in Wall 20 (cf. above), and a projection on this seems to show that the wall would have been bonded with Wall 20. The S. end is strengthened with two raised ashlar, on top of which another square ashlar is placed. Thus this part of the wall was clearly not bonded with Wall 12, but, on the contrary, it abuts against the exterior angle between Wall 12 A and B. Both sides of the wall are covered by a thick, soft revetment, white or yellow in colour, which has partly fallen from the upper parts of the wall. The revetment extends in behind two extra pillars built in the angles of Room X. (Concerning the wall paintings in this room cf. above. Figs. 225, 226, and 230; Plan XXXIX, 5).

Walls 24 A—B.

Width: 24 A: 0.45 m.; 24 B: 0.40 m.

Height: „ : 0.75 m.; „ : 0.40 m.

These walls are built close together the one beside the other. 24 A is built of dark river-stones and white lime-rubble kept together by loose, white mortar. Another kind of mortar, too, is used similar to that used in the wall of Room XII and Wall 21. Fragments of roof-tile are also used in the wall, which is covered by a revetment preserved on the N. face. The wall

is bonded to a square pillar placed in the angle between Walls 24 A and 23. The revetment also covers that pillar, which is built partly of rubble, partly of square ashlar. This revetment of Wall 24 A is, however, hidden by Wall 24 B, (Figs. 225 and 230) which is built close to it. This wall consists of somewhat larger rubble mixed with plenty of tile-fragments and held together with gypsum mortar. The wall is not bonded with other walls. The N. face has a stucco facing which is painted in the same pattern as Wall 23. (Concerning the paintings, cf. above. Plan XXXIX, 5).

Wall 25. Width: 0.50 m. Height: 1.50 m.

This wall is of the same construction as Wall 24 A and bonded with the square pillar built in the angle between this wall and Wall 20. The facing of the walls has no paintings. The wall is not bonded with Walls 20 or 24 B, but certainly with Wall 24 A. Through the S. part a door is built, the threshold of which is preserved *in situ*. The width of the doorway is 1.40 m. (Fig. 226).

Wall 26. Width: 0.42 m. Height: 0.50 m.

This is built of rather small rubble held together with gypsum mortar. The S. face is covered by a soft, yellow facing. The wall is founded on the rock, and is built close to Wall 20, partly covering its painted facing (cf. above). The wall might have been prolonged to the E., but, as the present end is strengthened by large raised ashlar, this seems not to be the case (cf. the end of Wall 28).

Wall 27. Width: 0.48 m. Height: 0.50 m.

It is of the same construction as the preceding wall, though the revetment to a great extent has gone. Almost round rubble or river-stones are used. The wall is founded on the rock. The W. end is finished about 0.50 m. from Wall 26. The E. part is built upon Wall 18. It could not be ascertained how far its original extent in that direction was brought forward. (Fig. 226).

Wall 28. Width: 0.42 m. Height: 0.50 m.

It is of the same construction as the preceding wall, though more white lime-rubble is used. It is founded on a layer of *chavara*. To the W., the wall surely was prolonged to an uncertain extent, though this part had been entirely removed. Here, however, it must have been founded on the rock. The E. part ends with a large pillar-like ashlar, as Wall 26. (Figs. 226 and 228).

Wall 29. Width: 0.47 m. Height: 0.70 m.

This piece of wall consists of two long ashlar, with a short piece of rubble-wall between them. The ashlar are held to the rubble by a hard, white gypsum mortar. The wall is founded on loose earth containing plenty of *chavara*. The wall is not bonded to Wall 11. (Fig. 263).

Wall 30. Width: 0.45 m.

It is a short piece of wall, nearly in line with the preceding wall, but quite different from it. It is built of rounded rubble held together with white gypsum mortar, and founded in a small depression of the rock. The W. face of the wall is well marked with larger rubble, but the E. face seems to be more uncertain. Possibly the wall once was wider. It may be explained as a base for a support of the same type as Nos. 31—33 (cf. below).

Wall (base) 31. Width: 1.20 m.

This wall is of the same character as the preceding one. It is, however, not founded on the rock, but on a layer of earth. The S. face is indeed leaning against the edge of a deep depression in the rock. Because of that, it is still preserved *in situ*. The rest, however, was removed shortly after its uncovering. The original extent of the wall is indicated by a dotted line on the plan. Probably the wall can be explained as a base for a support.

Wall (base) 32. Width: 1.30 m.

Apparently this wall has served a similar purpose. It is of the same character as the preceding wall, but it is founded on a large substructure wall, which has been built in the above mentioned depression in the rock. At the building of this substructure wall, which faces the rock, Wall 3 has been cut off. The substructure wall is of a solid character with the faces carefully built with larger rubble.

Wall (base) 33. Width: 0.85 m.

Another base of a quite different kind is situated in line with the preceding bases, and to the E. of them. This base (Wall 33) consists of rubble, and roughly cut ashlar on the S. part, held together with white mortar. The base is partly built on the rock and partly on top of Wall 14, which here is only preserved to a slightly higher level than the rock.

As the walls 30—33 are all situated on the same axis and at about the same level they can be explained as bases for a row of pillars or columns. In that case, a base should have existed between Walls 32 and 33, which must have been removed (cf. the row of bases Nos. 34—37 along Walls 26—28. Fig. 226).

Wall (base) 34. Width: 0.60 m.

This base is situated close to the steps which lead up to Room X. It is of the same construction as the preceding base partly built of ashlar, partly of rubble. It is founded on the rock.

Wall (base) 35. Width: 0.50 m.

This consists of a square ashlar, based on some small rubble fixed with white mortar. The base is founded on loose earth, which makes the filling of a large depression in the rock. Probably the depression is the remains of a demolished tomb.



Fig. 230. Soli. Upper courtyard, Room VIII, of Temple B, from the North.

Wall (base) 36.

Width: 0.60 m.

This consists of small rubble fixed to a square base by white gypsum mortar. The base is founded on a layer of earth and *chavara*.

Wall (base) 37.

Width: 0.60 m.

It is of the same construction as Wall 35.

Wall 38.

Width: 0.55 m.

This wall has a rather weak character. It is built of small rounded rubble and white limestone held together with grey cement-like mortar (cf. a similar mortar in Walls 21 and 24 A). The W. face has a soft, yellow revetment. The wall is founded on loose earth at the comparatively high level of 135.0. The wall abuts against Wall 8 but is bonded with Wall 39. (Fig. 260).

Wall 39.

Width: 0.45 m. Height: 0.60 m.

This wall is of the same character as Wall 38. Through the W. part there is a doorway, the remains of which consist of two pieces of the threshold-stone at level 142.5. To the W.

a square pivot-hole is noted. The width of the doorway is calculated to 1.90 m. This is bonded to Wall 40. (Fig. 260).

Wall 40.

Width: 0.40 m. Height: 0.80 m.

It is of the same construction as the two preceding walls. In this wall, however, plenty of fragments of terracotta tiles are used as building material. At a level of 30 cm. above the floor in Room XII, there is a horizontal line of such fragments. The wall abuts against Wall 8.

Wall 41.

Width: 0.40 m.

Bonded with the preceding wall, a fragment of another wall extends to the W. It is founded on earth, at the same level as Wall 40; here, too, plenty of roof-tiles are used among the rubble. The wall makes a right angle to the N. and is destroyed after 0.60 m. The use of this wall remains uncertain.

Wall 42.

Width: 0.62 m.

At a level of 130.0 below the floor of Room XII, there is a wall parallel to Wall 19 and running in S. to N. direction. The wall is built of rounded rubble with a straight, low course of rubble on the E. face. The W. face not very clear and loosely built of smaller rubble. The wall is founded on the sandy earth. The excavation of a similar wall, which runs to the W. was stopped after about 2.0 m.

Wall 43.

Width: 0.45 m.

This was not excavated entirely. It should be connected with the preceding wall.

Wall 44.

Width: 0.60 m. Height: 0.75 m.

This wall is built in a line with Wall 5, and joins this wall with Wall 45. The wall consists of rounded rubble, wedged with smaller stones loosely held together with white mortar, and is founded on the solid rock. Two large fragments of a limestone column with moulded base, measuring 0.63 m. in diameter are used as building-stones. The wall abuts against Walls 6 and 45. Against the E. face, there is a bench built along the Walls 44 and 45. The bench is built in the same technique as the Wall 44. Just in the angle, there is a piece of a Doric stone column built into the bench.

Wall 45.

Width: 0.55 m. Height: 1.05 m.

This is built on the rock, of rounded rubble, wedged with smaller chips. The faces are rather carefully built with larger, often triangular rubble. The S. face is covered by thick, yellow stucco, which is rather soft and loosely fastened to the wall. The wall begins at the N. angle of Room XVIII and runs to the E. close to the entrance of Room XVI. It passes over Wall 9 which is sunk in a trench in the rock. Possibly, the wall once was prolonged down to Wall 11. The E. part, however, is now entirely removed. Just to the E. of the point where



Fig. 231. Soli. Entrance into the *cella*, Room XVIII, of Temple C.



Fig. 232. Soli. Wall 52 and superimposed Wall 51.

the wall crosses Wall 9, there is a square ashlar built into the wall on the rock. It is not impossible, that this ashlar originally served some other purpose than that of a building-stone. It may be connected with another square ashlar, or base lying in line with it in the angle between Walls 9 and 10 A. Both ashlar lie on the same axis and close to Wall 9 and may have served some purpose in connexion with this wall.

Wall 46.

Width: 0.60 m. Height: 1.20 m.

The wall is of the same construction as the preceding wall. The W. face is more carelessly built. The E. face, on the contrary, is covered by the same kind of revetment as the S. face of Wall 45. The wall is founded on the rock and partly sunk into a trench. In the middle, it crosses the dromos of a rock-cut tomb to the W. of Room XVIII. To the S. of this dromos, there is a small recess in the wall, much ruined.

Wall 47.

Width: 0.52 m. Height: 0.65 m.

It is of the same character as the preceding wall. It too, is founded on the rock and covered with a revetment on the N. face. The wall is bonded with Wall 49.

Wall 48.

Width: 0.52 m. Height: 0.90 m.

This is of the same character as the preceding walls. It is covered with the same kind of revetment on both faces. The N. end is strengthened by some larger, roughly cut ashlar. Through the N. end of the wall there is a doorway just above Stair 162. The threshold stone (level 136.0) is preserved *in situ* and provided with a square pivot hole at the S. angle. The width of the doorway is 1.05 m. The S. end abuts against the angle between Walls 47 and 49.

Wall 49.

Width: 0.55 m. Height: 0.70 m.

This is of the same character as Wall 48. It is founded on the rock and bonded with Walls 47 and 50.

Wall 50.

Width: 0.50 m. Height: 1.00 m.

This wall makes a right angle with the preceding wall with which it is bonded. In the N. part, the wall is of the same type as Walls 45—49, and is here built as a facing for the rock behind it. The middle part of the wall had been removed. The rock here comes near the surface, but slopes rapidly to the E. There, the wall is preserved. It is founded on the rock and built of rubble of the same kind, as in the W. part. The revetment is, however, lacking. The wall is bonded to Wall 52.

Wall 51.

Width: 0.60 m. Height: 0.70 m.

This wall is built of rounded, often triangular rubble of ordinary size. Mortar seems not to have been used for fixing the stones together. The wall is founded on a layer of *chavara* at the level of 112.0. The upper level of the wall is measured to 118.8. The wall is bonded with Wall 53 and probably, too, with Wall 10 A, though the connexion with the latter wall could not be clearly ascertained. To the S. the wall is cut off by the Wall 50 (Fig. 232).

Wall 52.

Width: 0.55 m. Height: 1.00 m.

Partly on top of the preceding wall, but diverging slightly from it; the wall is built very solidly of large, rounded rubble mixed with white limestone held together with hard gypsum mortar. The E. face is covered with a revetment of white gypsum of the same kind used as mortar in the wall, but only above the level of the water-conduit which runs along the wall on the E. side. Below the conduit no revetment is to be found. Near the middle of the wall, there was a passage through the wall, 0.70 m. wide, which, subsequently had been filled up with large lime-ashlars, held together with white gypsum. The revetment on the E. face covers this door-filling. The wall seems to have been heightened by another layer of stones built on top of the other wall, and bridging over the door-filling. This heightening of the wall may have been made at the same time as the filling of the door. The wall which abuts against Wall 11, is bonded only with Wall 50. Other walls (10 B, 56, and 22) abut against the wall. As the revetment mentioned is bonded with the water-conduit and, also, covers the door-filling, the building of the conduit and the uppermost part of the wall with the door-filling must be contemporary. (Figs. 232 and 238).

Wall 53.

Width: 0.55 m. Height: 1.80 m.

This wall is of the same construction as Wall 51, and is, like that wall, founded on a layer of *chavara*. Two parts can be distinguished: — The lower, or substruction, built of dark rounded rubble without mortar, and the upper, with the same dark rubble mixed with white limestones and held together with white mortar. The wall is clearly bonded with Wall 51, but the upper part of it has been cut off, at the building of Wall 52. Possibly this upper part of Wall 53 was bonded with an upper part of Wall 51, which, however, was removed to give place for Wall 52, in line with Wall 11. The W. part of Wall 53 abuts against a rock face which was lined with Wall 54. (Fig. 261).



Fig. 233. Soli. Lower courtyard of Temple B, with walls (1—4) below floor. In the fore-ground, Column-bases 35—37.

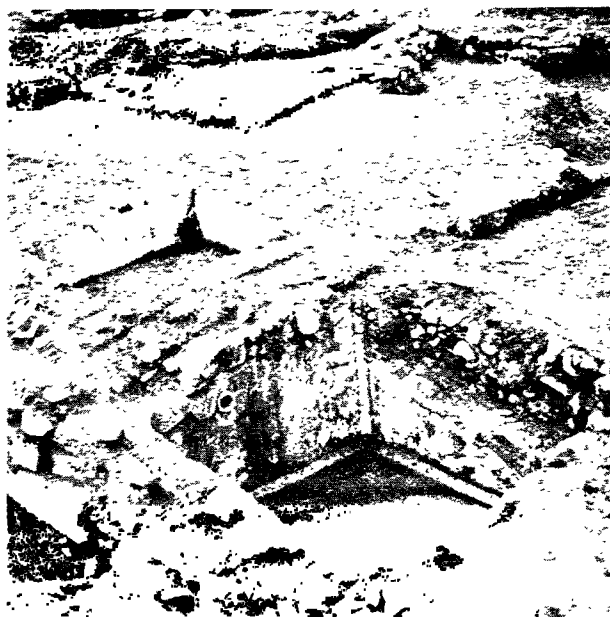

Fig. 234. Soli. Cisterns 169 and 170, from the South.

Wall 54.

This wall seems to have been of the same character as Wall 10 A. It is, however, very much destroyed. The stones were fallen to the E. of it. It was probably bonded with Walls 10 A and 53.

Wall 55.

Width: 0.80 m. Height: 0.50 m.

This wall probably constitutes a part of the temenos wall. It is founded on the rock and abuts against Wall 50. The wall seems to run along the water-conduit 167. Whether the break in the wall just opposite Cistern 168 is a doorway or a mere damage on the wall is uncertain. (Fig. 241).

Wall 56.

Width: 0.25 m. Height: 0.60 m.

This wall is built of small rubble without mortar, and with a very rough face. It was not possible to distinguish if the wall is only a substruction for Wall 22 and built in connexion with that wall, or if it ought to be connected with Wall 57. The wall abuts against the substructure of Wall 52, and is founded on a layer of earth. This fact indicates that the former assumption may be the right one. (Fig. 237).

Wall 57.

Width: 0.45 m. Height: 1.50 m.

This is built of comparatively small, rounded rubble, irregularly placed. No mortar seems to have been used for fixing the stones. The wall is founded on the rock and runs along the E. side of a trench or conduit excavated in the rock. The lower part of the W.



Fig. 235. Soli. Room XXIII, from the North. Floor-filling partly removed in order to show Walls 53 and 57 below the floor.



Fig. 236. Soli. Stratification of Room XXIII. To the left, Wall 57.

face is very roughly built with many projecting stones. The wall runs below Wall 65 and abuts against the vertically cut rock behind Wall 71 A, the substructure of which is divided into two parts by Wall 57. On the other side, it was very difficult to state whether it was bonded with Wall 56, or not. The upper parts of the wall have been demolished for the levelling of the floor of Room XXIII. (Figs. 235 and 236).

Wall 58.

Width: 0.45 m. Height: 0.80 m.

This wall is of the same construction but here gypsum mortar is used to fix the posts of a doorway through the wall. These door-posts are strengthened, too, by larger lime-rubble. The width of the doorway is 0.90 m. (Fig. 235).

Wall 59.

Width: 0.58 m. Height: 0.75 m.

This wall may have been a part of the preceding wall, situated as it is on the same line. It has, however, been cut off by Walls 123, 133—135, and further down by the entrance through Wall 125. The wall is built on the rock of rounded rubble. Evidently, it has been levelled when the floor of Room LIV was laid, so that all its higher parts above this level have been removed. In the W. parts, only the S. facing-stones of the lowest course thus are preserved. The bad state of preservation here depends on the fact that the rock comes up to a rather high level on this spot. Further to the E., the rock slopes, and there the wall is better preserved. (Figs. 260 and 266).



Fig. 237. Soli. The joint between Walls 52 (left) and 56 (right). In the middle, Water-conduit 167.



Fig. 238. Soli. Room XXIV, with Water-conduit 167, from the South.

Wall 60.

Width: 1.15 m. Height: 0.75 m.

This belongs to the same system of walls as the preceding one. The wall consists of two parts lying close together and built of large mixed rubble without mortar. The walls are founded on the rock and were levelled to the floor of Room LIV. Probably the wall was connected with Wall 59. It disappears below Wall 132 and has, evidently, nothing to do with the latter. (Figs. 259 and 265).

Wall 61.

Width: 0.40 m. Height: 0.40 m.

It is of a similar construction and founded on the rock. The wall disappears below Wall 132, which in its lower part abuts against the former. The wall should be connected with the following wall. (Fig. 265).

Wall 62.

Width: 0.45 m. Height: 0.45 m.

This wall is of the same construction as the preceding one in its S. parts. It was connected with Wall 61 by a short piece of wall which extends to the N. Through Wall 62, there was a door crossed by the subsequent Wall 59 described above. On the other side of the door, a short piece of the wall is visible. This disappears, however, below the angle between Walls 136 and 137.

Wall 63.

Height: 0.40 m.

This wall is connected with the preceding wall and makes a right angle with it. It was founded on the rock. Only the S. face was uncovered.



Fig. 239. Soli. The eastern portion of Temples E (background), and F (foreground).



Fig. 240. Soli. Wall 79 and remains of Stair 163.

Wall 64.

Width: 0.55 m. Height: 0.75 m.

This wall is built of rounded rubble and white limestone held together with white gypsum mortar. Ashlars are also used as building-stones, built in with the rubble. The wall which is founded on loose earth at the level 112.7, is strengthened by two square pillars, solidly built with gypsum mortar. A similar pillar is to be seen in the angle between Walls 64 and 65. The wall abuts against Wall 22. (Fig. 238).

Wall 65.

Width: 0.40 m. Height: 0.70 m.

It is of the same construction as the preceding wall, but with only one gypsum pillar in the middle of the wall.

Wall 66.

Width: 0.45 m. Height: 0.60 m.

It is of exactly the same construction as Wall 64.

Wall 67.

Width: 0.70 m. Height: 3.40 m.

The lower part of this wall (67 A) is built of rounded dark, or grey rubble, fixed together with white hard gypsum mortar. This gypsum covers both faces of the wall and is smoothed to a level surface on the parts which were visible; on the lower parts, on the contrary,

which apparently were meant as substruction walls below earth, the gypsum was smeared only in the joints between the rubble. Here the traces of the workers' fingers could be seen, especially on the face below the floor of Room XLV.

For technical reasons, it was impossible to excavate the wall to its lowest part, but probably it was founded on the rock. There is a great difference of level of the rock in Room XLV and Room XXXIV so that the rock is found on a much higher level in the latter room than in the former, where it was impossible to reach it by diggings. The wall is partly built as a revetment wall, against the rock plateau in Room XXXIV (cf. a similar arrangement on the opposite side of this rock plateau on which Rooms XXXIV and XXXV are situated, Section X).

The highest level of the lower wall can now be studied on the face towards Room XXXIV, where a horizontal cut through the whole wall is noticed. The part below this cut belongs to an original building, that one above it is subsequent. This cut is still more evident on the face towards Room XLV, where the upper part does not fill the whole width of the lower part. This part is bonded with the lower parts of the Walls 73 and 68 but not with Wall 88. The wall is also bonded with two supporting buttresses below Wall 98 and outside the angle 67—68. These supporting walls are very substantially built, the stones being of the same kind as in Wall 67 A fixed together by gypsum mortar.

The upper part of Wall 67 (B) is built partly of the same kind of rubble as the lower part, but the bulk of the building-stones consists of large, white lime blocks. Scanty remains of gypsum mortar are found in the wall, but no gypsum revetment was preserved on the face. The upper part (B) is bonded with the upper part of Wall 73, but not with Walls 88 and 68.

Still a third part is connected to this wall on the face towards Room XLV. It was founded on the floor of this room, and is connected and bonded with the altar bench there (cf. below). Thus this wall is a side bench of the same kind as that one found to the left of the entrance close to Wall 89. Its upper surface originally was on the same level as the altar bench. (Concerning the stucco-paintings cf. above).

Wall 68.

Width: 0.70 m. Height: 1.20 m.

Like the previous wall, this one consists of two parts corresponding to the two parts A and B of Wall 67. Here, too, the different kinds of material are noticed. The lower part is founded on the rock. Only a rudimentary part of the upper wall is preserved to the N. The face towards Room XXXIV is covered by a gypsum revetment and smoothed. The outside of the wall, on the contrary, which possibly was hidden below earth is very rude with projecting stones and no straight face. In the N. angle of Room XXXIV the wall is bonded with the corresponding parts of Wall 69. (Fig. 241).

Wall 69.

Width: 0.65 m. Height: 1.20 m.

This is of the same kind as the previous wall, with two parts: The upper part (B) is somewhat narrower than the lower part (A). The lower part consists of black, or grey rubble



Fig. 241. Soli. Walls 88 and 68 from the South.



Fig. 242. Soli. Remains of Stair 164 of Temple D, and Wall 103 (to the right) of Temple E. In the background, Walls 105 and 106.

faced with gypsum; the upper part is built with rough lime-blocks without any gypsum revetment. A vertical break in the part (A) aligned with the E. face of Wall 70 is probably to be connected with the building of the altar in Room XXXIV (cf. below). The part (A) is bonded with Wall 70 A and with Walls 72—73 A. (Figs. 245, 246, and 264).

Wall 70.

Width: 0.55 m. Height: 1.35 m.

The same arrangement with two parts in the wall is noticed here, too, as in the previous walls. The interior face of the part (A) is now hidden by an altar in Room XXXV, but was uncovered close to the W. angle of Room XXXV, where the wall was bonded with Wall 69 A. This face was covered with a gypsum revetment. The exterior face shows the same rough character as Wall 68. The upper part of the wall (B) is preserved only to an unimportant height and this part is narrower than the part A, so that there was a sort of socle made of the part (A) on the exterior face.

Wall 71.

Width: 0.60 m. Height: 1.10 m.

This wall is of the same construction as the previous walls, with two parts distinguishable. The lower part (A) is founded on the rock just above a vertically cut edge. The wall extends



Fig. 243. Soli. Wall 80 from the East and corner of Altar 153 of Temple D, superimposed by Wall 105 of Temple E.

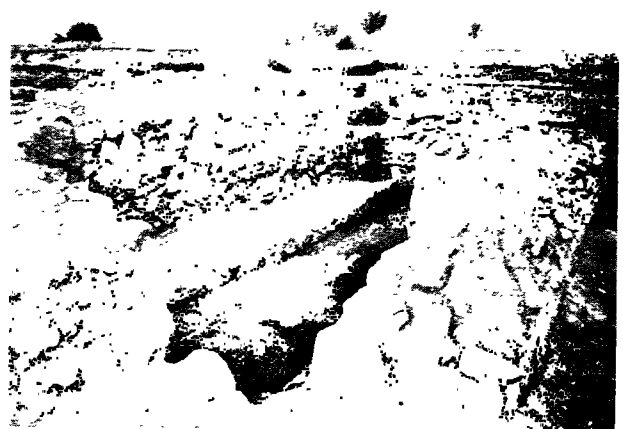

Fig. 244. Soli. Room XLII of Temple E, built above Wall 84 of Temple D.

downwards facing the rock-edge. The lower part of this revetment is destroyed. It is in line with a piece of wall further down in Wall 123 (cf. below, Wall 82). The upper part of the wall (B) is of the same construction and material as the corresponding parts of the previous walls. The upper part is preserved only in the N., where it is bonded with 70 B.

Wall 72.

Width: 0.60 m. Height: at least 1.95 m.

This wall is of the same construction and material as the previous one. It is founded on the rock with a socle carefully built of rubble. Against the face towards Room XLIV there is a revetment wall of small rubble founded on earth and extending up to the threshold level. The central part of the wall is interrupted by a doorway, 1.67 m. wide, the jambs of which are strengthened with some large, roughly cut stones. The threshold consists of flat slabs, slightly worn and solidly held together with gypsum mortar. To the W. of the doorway there is a 2.40 m. wide step built of oblong ashlar. Pivot holes are visible in two of these ashlar. (Fig. 245).

Wall 73.

Width: 0.55 m. Height: at least 1.80 m.

It continues the previous wall, and is of the same material and construction as this, but without any revetment wall in front of the door. The wall has deep substructures built as lining walls for the vertically cut rock-edge close to the wall. Below the jambs, these substructures contain solid pillars or supports, held together with very hard gypsum. Close to the N. jamb, there is on the outside of the wall a square part, built very solidly and faced with gypsum mortar, the object of which is rather obscure. Through this wall there is a doorway of the same type as in Wall 72. The center of the threshold and step is, however, damaged.

Wall 74.

Width: 0.80 m. Height: at least 1.30 m.

The wall diverges slightly from the preceding walls, but seems to be parallel with Walls 79 and 84. It extends from a point in line with the N. jamb of the door to Room XLV, to



Fig. 245. Soli. Room XXXV with Altar 155
in the rear.



Fig. 246. Soli. Altar 150.

Wall 92 under which it disappears without any bond. The wall is very loosely composed of rubble of various sizes. No mortar is to be noticed. The wall is founded on the rock. The S. E. face is carefully built with larger stones, usually in one course only. The other face, on the contrary, is very carelessly built without any straight line, and on this side of the wall the smaller stones are placed. The wall is connected with two buttresses in line with the edges of the stair described below. These buttresses fix it to Wall 73: they are, however, not bonded with the latter wall. Wall 74 abuts against Wall 75. If it is connected with some wall below Wall 92, could not be stated.

Against the S. E. face of the previous one another foundation is built extending just in front of Room XXXIV. This foundation consists of two parts: close to Wall 74 the wall is built of small, carelessly laid rubble in places held together with gypsum mortar. Towards the E., the foundation is lined with a row of ashlar, the edge of which were slightly worn. The ashlar and the rubble connected with them were founded on the loose filling of *chavara* at level 109.0. Evidently this wall is the substruction for a wide stair, the lowest step of which is preserved as a row of worn ashlar. (Fig. 242).

Wall 75.

Width: 0.65 m. Height: 0.60 m.

The wall is built of small rounded rubble without mortar. The wall is founded on a layer of *chavara* at the level 105.0. It abuts against Walls 98 and 100.

Wall 76.

Width: 0.50—0.70 m. Height: 1.40 m.

This wall is of a solid construction and built of rubble of ordinary size. No mortar is used for fixing the stones. The wall is founded on the rock, which here slopes towards the W. The rubble is placed rather regularly across the wall, so that the faces are carefully set. The wall extends towards Room XLV below Wall 96, but it was here impossible to follow the wall further than what is to be seen on the plan. At this point the wall thickens somewhat and is strengthened by a gypsum wall-pillar of very solid character (Figs. 250 and 252). The wall is bonded with --

Wall 77. Width: 0.40 m. Height: 1.70 m.
 which is of the same material and construction as that wall. It had been raised to the level of the floor in Room XLVI.

Wall 78. Height: 0.20 m.
 This wall is of a very weak character. It consists of a row of small grey rubble mixed with white limestones, built in only one layer. The stones are held together with white gypsum mortar. The wall is founded on the rock just where it begins to slope towards the S. and is in line with Wall 76. Evidently it should be considered as a facing for the rock floor to the E. of the wall. The wall is bonded with the next wall, which makes a right angle to it.

Wall 79. Height: 0.50 m.
 This wall is of the same character as Wall 78. It is partly preserved in two courses of stones, and in the E. part some larger stones are noticed, 30—40 cm. long. The wall is lined with gypsum, which extends over the whole face with the exception of a piece just in front of the lime-ashlars behind Stair 163. Near this staircase, a doorway must be supposed through the wall, the remains of which have now vanished. (Fig. 240).

Wall 80. Width: 0.25 m. Height: 0.50 m.
 This is of the same character as the previous one and is bonded to it in the E. end. The gypsum facing is well preserved (Fig. 243). The wall is bonded to —

Wall 81. Width: 0.25 m. Height: 0.30 m.
 which makes a right angle with it. This wall, too, is of the same weak character and serves as a facing for the rock-floor. The wall runs to the N. E. and disappears below Wall 92. How it was finished can not, in the present circumstances, be determined (cf. Fig. 243 and the conjectural reconstruction, Fig. 274).

Wall 82. Width: 0.75 m. Height: 1.90 m.
 Short fragment in Wall 123 (cf. below). The wall is founded on the rock with a solid base of flat lime-ashlars. On this base the wall is built very solidly of small rubble held together with hard gypsum mortar. The wall is built as a revetment wall against the vertically cut rock, below Wall 92, and has partly been built over by Walls 92 and 123 in subsequent periods. Only a very small part of the wall remains just at the intersecting point between these walls. The rest has been destroyed, evidently with some difficulty. The reason why the main part of the wall has been removed seems hard to explain. (Fig. 256).

Wall 83. Width: 1.20 m. Height: 0.40 m.
 Below the S. part of Wall 90, a wide, but very low wall begins and runs to the E. It consists of comparatively small rubble the larger of which is placed at the edges and held together with hard, white gypsum. The wall is founded on the rock and is bonded to —



Fig. 247. Soli. Remains of Wall 82 preserved at the joint between Wall 92 and 123, from N. W.



Fig. 248. Soli. Stratification close to the North façade of Wall 85, below the floor of Room XLV.

Wall 84.

Height: 0.20 m.

This is of the same type as Walls 78—81 and is built as a facing for a rock-floor to be seen beneath Wall 90. The wall consists of small rubble held together with hard gypsum mortar. The E. face of the wall is more carefully built than the N. one, which abuts against the rock. The wall extends below the staircase which leads up to Wall 90. Connected with this wall, there are some ashlar placed as a step, S. of the stair mentioned. These are the remains of the same stair, which leads up to Wall 79. (Fig. 244).

Wall 85.

Width: 0.60 m. Height: 2.10 m.

This wall runs at a comparatively low level from below Wall 100, below Wall 98, the Altar 156 in Room XLV, and Wall 88, outside which it forms an angle to the S. W. (Wall 86). The Wall consists of two separate parts, differing in building-technique. The E. part of Wall 85 is built entirely of well wedged, rounded rubble without mortar. W. of Wall 98 there is a vertical cut in the wall. This cut has been built over by the subsequently added W. part of the wall, which contains similar rubble, but is here mixed with many pieces of ashlar and other stones, evidently used as building material before. No mortar is used in this part either. For technical reasons it could not be ascertained, if the wall was founded on the solid rock or not. The wall was excavated to level 93.0 though without

uncovering its lowest part. It had been demolished just sufficiently to make room for the walls and floor of Room XLV. It had been partly built into Wall 88. (Fig. 248).

Wall 86.

Width: 0.55 m.

This continues the preceding wall to the S., and is of the same construction as this. The wall is built as a facing against the rock to the W. of it. Because of that, the E. face is more carefully built. The wall was never uncovered for its whole length, as the excavation was restricted at this point. (Fig. 241).

Wall 87.

Width: 0.50 m. Height: 2.00 m.

Only a short piece of this wall could be examined between Walls 85 and 89. Here it is of the same construction as the E., *viz.* original part of Wall 85, to which it also is bonded. To the S., the wall extends below Wall 89 without any connexion with that wall. As Wall 85, this wall had been demolished to the level of the lowest parts of the walls of Room XLV.

Wall 88.

Width: 0.80 m. Height: 2.40 m.

The wall consists of one upper and one lower part, differing much in building-technique. The joint between the parts mentioned was situated at the same level as the altar bench of Room XLV, or 121.0. This joint is especially well marked on the W. face, where the upper part even projects over the lower one. The lower part, which evidently was covered by earth, was carelessly built of dark comparatively small rubble without mortar. The lower part is founded on a layer of *chavara* at the level of 105.0. The upper part, on the contrary, contained large rubble mixed with white limestones and wedged with small chips of limestones. This part is held together with hard, white gypsum mortar, and its E. face was covered by painted stucco (cf. above). In the S. part, a fragment of a round column similar to those in Wall 44 was built in, as a building-stone. Both parts of the wall abut against Wall 67, but are bonded with the corresponding parts of Wall 89. (Fig. 241).

Wall 89.

Width: 0.80 m. Height: 2.40 m.

This is of the same construction as the preceding wall, and consists also, of two parts corresponding to those of that wall. On the outside of the upper part, a gypsum revetment is preserved in the W. part of the wall. Probably, this indicates the ground level at that time. E. of Wall 98 the wall changes its character. Here the lower part, or the substructure wall is partly held together with hard gypsum mortar, and this part thickens on the N. side of the wall to a sort of socle, which is rather roughly constructed. The substructure is founded on a layer of loose *chavara* at levels which can be studied on Sections IX—XV, p. 465.

The lower part of the wall is bonded with Walls 88, 98, and 93; the upper part with Walls 88 and 93. Wall 77 has been built into the substructure part of the wall. — In front of the apse of Room XLVI there seems to have been a doorway through the wall. The remains of this, consist of a jamb built of rubble and the gypsum foundation for the threshold stone. The original width of the doorway is, however, impossible to fix. (Figs. 250 and 264).

Wall 90.

Width: 0.50 m. Height: 1.25 m.

This wall consists of two parts, the lower of which is a carelessly built substructure wall founded on the rock. This lower part consists of comparatively small rounded rubble. No mortar is here used for fixing the stones. The upper part is more carefully built with straight faces on both sides. In this part the rubble is of somewhat larger size, wedged with stone chips and held together with gypsum mortar. The upper part of the wall is slightly narrower than the substructure, which was hidden by earth below the floor of Room XLIII D. The wall abuts on the S. against Wall 89, and on the N. against a substructure pillar, for the stair (165) which leads up from Room XXIX. (Figs. 240 and 263).

Wall 91.

Width: 0.45 m. Height: 1.35 m.

This wall is of the same type and construction as the preceding wall. To the S., it abuts against a second substructure pillar for the stair mentioned. To the N., however, the lower part of the wall is bonded with the substructure part of Wall 92. (Figs. 240 and 263).

Wall 92.

Width: 0.68 m. Height: 1.50 m.

This wall consists of two parts, the lower of which is of a construction similar to the lower part of Wall 91. It is, however, strengthened by square, solidly built pillars in the wall, which are founded on the rock. One of the pillars is situated near the angle between Walls 91 and 92, the others at equal distances in the middle of the wall. Only in the most W. part of the wall, the lower part is connected and bonded with the upper part, and of the same width as this. E. of Wall 123, on the contrary, the upper part is built on top of the lower part, so that this projects out some 0.10 m. on the S. face. This upper part, too, contains solidly built pillars of a similar construction as those in the lower part, but they are not placed on top of these. Only the third pillar, from the E. is based on one of the pillars of the lower wall. The upper part of the wall, with the exception of the westernmost part, is built of white lime-rubble of comparatively large size and held together with hard gypsum mortar. Most likely the E. part of the wall was subsequently repaired.

The S. face was probably covered with a soft revetment, some scanty remains of which are still preserved. The N. face is covered with a hard gypsum revetment, which on this side extends over the lower part of the wall, and makes the side wall of Room LVI. The W. piece of the upper wall, which is bonded with the lower part is of quite a different character. Here both parts are of the same width, and the S. face of the upper part is covered with stucco, possibly once painted.

The W. end abuts against Wall 72. At the E. end, the lower part is bonded to Wall 91, the upper part to Wall 125. The wall runs over Wall 74 and 81, but without any connexion with these walls. At the E. end of the wall, there must have been a doorway just above the Staircase 166, though no traces of this passage are now to be seen. (Figs. 249 and 265).

Wall 93.

Width: 0.55 m. Height: 1.20 m.

This is of a construction similar to Wall 90. It is bonded with Wall 89 and also with Wall 94.



Fig. 249. Soli. The courtyard (Room XLIII A) of Temple E, with floor-stratum removed so that remains of Altars 152 and 153 are visible, from the West.

Wall 94.

Width: 1.80 m. Height: 1.10 m.

This wall is built of rounded rubble of various size and founded on the rock. The S. face is strengthened by large rubble held together with hard, white gypsum mortar. No mortar is used in the N. part of the wall where the stones are of smaller size. The wall is bonded with the lower part of the preceding wall and with Wall 95.

Wall 95.

Width: 0.80 m. Height: 0.50 m.

Here two parts of the wall are to be distinguished. The lower one consists of rounded, dark rubble held together with gypsum mortar. In the upper part, which extends only over half the width of the foundation wall along its E. face, it is very solid. In this part, some fragments of statues were used as building material. The wall is founded on the rock. It covers some foundations of the staircase leading up to Wall 84, and is bonded with the S. foundation wall of the large staircase (165), which leads up from Room XXIX to Room XLIII. (Fig. 221).

Wall 96.

Width: 0.70—1.30 m. Height: 1.10 m.

This wall runs in line with the preceding wall, on the N. side of the staircase mentioned. It is built of rounded rubble of various size, the larger stones being placed on the edges

of the wall. No mortar is used for fixing the stones, but they are wedged with stone chips. The wall, which is founded on the rock, thickens very much to the N. The E. face is straight and well built, but the opposite one is curved and rather carelessly built. The core of the wall between the faces is like a heap of stones. The wall is bonded with the N. supporting wall for the staircase mentioned to the S. of the wall. The N. part of the wall is bonded with Wall 97. (Fig. 244).

Wall 97.

Width: 2.30 m. Height: 1.00 m.

This continues the preceding wall in W. direction. The wall is of the same construction and material, and bonded with the lower part of Wall 91, but not with Wall 125 which is situated at a higher level.

Wall 98.

Width: 0.60 m. Height: 1.30 m.

This wall is built as a foundation for the door to Room XLV. It consists of comparatively small, rounded, dark rubble in the upper parts held together with hard gypsum mortar. This part of the wall below the threshold is founded on loose earth at the comparatively high level of 111.0. To the S. of the threshold the wall has the same construction as Wall 89. It is also founded on the same layer and level as that wall (cf. above), against which it abuts. To the N., the wall abuts against the solidly built buttress of Wall 67. The doorway through this wall is of the same character as those through Walls 72 and 73. The step with pivot holes inside the entrance is, however, here lacking. The threshold stones had all been removed, but traces of them are to be seen clearly on their gypsum foundation. The level of this is 115.0 and the width of the entrance is 1.65 m.

Wall 99.

Width: 0.35 m. Height: 0.50 m.

Partly covering Wall 85, there is a short piece of wall built of small rubble mixed with limestone. Both faces are covered with a hard gypsum revetment. At the E. end, a fragment of a statuette (No. 340) was used as a building-stone. The wall was probably a foundation for a bench along Wall 89. The three following walls have served this purpose also. (Fig. 281).

Wall 100.

Width: 0.50 m. Height: 0.30 m.

This wall consists of rounded rubble mixed with a few ashlar held together with hard gypsum mortar, which also covers the faces. The wall is founded on a layer of earth, and is not really bonded with Wall 84, though it is partly built over the foundation of that wall. To the E. it abuts against one of the gypsum pillars of Wall 103 with which it is aligned. On the upper side of the wall a worn ashlar at level 115.0, indicates that there was a door through the wall. Of this doorway nothing is preserved, but the door seems really to have existed (cf. below). (Figs. 242 and 250).



Fig. 250. Soli. Walls 100—102 from N. W.

Wall 101.

Width: 0.30 m. Height: 0.20 m.

This might have been a wooden wall lined with gypsum. The remains of it now consist of this lining which once surrounded a wooden beam. On the inside of the lining, traces of the wood are still to be seen. The beam was lined with gypsum on the underside, too, which seems to indicate the original foundation level of the wall, which is almost identical with that of the next wall. (Figs. 250 and 251).

Wall 102.

Width: 0.25 m. Height: 0.20 m.

This wall is parallel to the preceding wall, but diverges slightly to Wall 76, on top of which it is partly built. The wall has a very weak character. It is built of rounded rubble of ordinary size. The faces are covered with a gypsum revetment. The rest of the wall is founded on a layer of earth. The wall abuts against Wall 100, and was probably prolonged to the E. for an uncertain distance. (Fig. 250).

Wall 103.

Width: 0.75 m. Height: 0.55 m.

This wall is parallel to Walls 72—73—98 and runs between Walls 100 and 104 on the same line as these. The wall is built of dark rounded river-stone, without mortar, and with

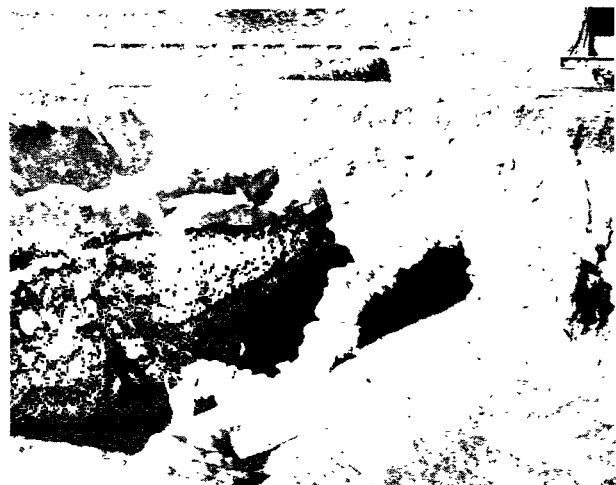

Fig. 251. Soli. Stratification above Walls 75 and 99.

Fig. 252. Soli. Room XL built over by Wall 89.

a rather rough building-technique. Though the wall is wide, it gives a very weak impression. The ends of the wall are, however, strengthened by solid substructure pillars, built with gypsum mortar. As far as could be ascertained, the whole wall is founded on the rock. The wall is not bonded with other walls. (Figs 242. and 249).

Wall 104.

Width: 0.75 m. Height: 0.90 m.

This wall continues the preceding wall, but is of a different character. It is built of rubble mixed with white limestone partly held together with hard, white gypsum mortar. The wall is not founded on the rock, but on a layer of earth, about 0.30 m. above the rock. The N. part of the wall is preserved to a higher level (118.3) than the S. part, where the preserved level is the same as that of Wall 103. The wall abuts against Wall 92. (Fig. 242).

Wall 105.

Width: 0.25 m. Height: 0.30 m.

This wall is of a very weak character and consists of comparatively small rubble held together by gypsum mortar. The S. face is lined with a gypsum revetment, which is preserved especially in the E. part. The wall is founded on a layer of earth and abuts against Wall 104 and the threshold in Wall 72.

Wall 106.

Width: 0.35 m. Height: 0.55 m.

At the same level as the preceding wall and parallel to it, is a row of three raised ashlar held together with gypsum mortar. To the N. of these ashlar, there is a bench of rubble which is built against Wall 92 covering its stucco revetment. Almost certainly, the wall served the same purpose as the preceding wall, probably as the foundation for a bench outside Room XXXV.

Wall 107.

Width: 0.65 m. Height: 0.40 m.

This wall is of a very bad construction and consists of rounded rubble of various size, built up very irregularly. No mortar is used for fixing the stones. With the present state of

preservation, the original faces are hardly to be distinguished. The E. end of the wall is marked by a solidly built substructure pillar just W. of Wall 79. The wall is founded on a layer of earth about 0.30 m. above the rock and passes over the S. altar in Room XXXI. The wall abuts against Wall 103. At the middle of the wall, a piece was destroyed in digging the second trial trench. The bad state of preservation made it difficult, almost impossible, to separate the wall from the surrounding loose stones in the earth. (Figs. 249 and 263).

Wall 108. Width: 0.60 m. Height: 0.40 m.

This is of exactly the same material and construction as the preceding wall. It is also founded on a layer of earth at the same level as Wall 104 and runs over the E. altar in Room XXXI. The most E. part of the wall is founded on solid rock. To the W., the wall abuts against Wall 103. Both Wall 107 and 108 are of too bad a construction to support a high wall. Probably they were built as stylobate for wooden columns. (Figs. 240, 243, 249, and 263).

Wall 109. Width: 0.48 m. Height: 1.00 m.

The following six walls evidently belong to subsequent buildings, built against Wall 89. The wall consists of dark rounded rubble held together with gypsum, which also covers the faces of the wall above a certain level. The facing stones are of larger size than the stones in the core. The wall is founded on a layer of earth and abuts against Wall 89. It is bonded with the next wall.

Wall 110. Width: 0.55 m. Height: 1.05 m.

This is of the same material and construction as Wall 109. Against the middle of the S. face, there is a semicircular apse, which is filled with smaller rubble than the stones which make the edge of the apse.

Wall 111. Width: 0.55 m. Height: 0.30 m.

It is of the same material and construction as the preceding walls, and is bonded with Wall 110 and abuts against Wall 89.

Wall 112. Width: 0.30 m. Height: 0.45 m.

It is a very weak wall which consists of a row of small rubble without mortar. The wall abuts against Wall 110.

Wall 113. Width: 0.25 m. Height: 0.45 m.

As the preceding wall.

Wall 114. Width: 0.50 m.

This wall is similar to Walls 109—111. It is founded on a layer of earth and abuts against Walls 111 and 115.

Wall 115. Width: 0.65 m. Height: 1.00 m.

This is built on a line with Walls 90—93 and is of the same building-technique as the preceding wall. It is founded on a layer of *chavara*.

Wall 116.

Width: 0.35 m.

It is of the same building-technique as the preceding wall. The E. face is rather carefully built. Both these walls abut against Walls 94 and 117.

Wall 117.

Width: 0.60 m.

This wall belongs to a building (Room XLIX) which can be separated from the other temples described below. The wall is of a rather careful construction built with large rubble revetted with gypsum mortar on the N. face. The wall is bonded with —

Walls 118—120 which are of the same construction. Width: 0.40; 0.60; 0.65 m.

Wall 121.

Width: 0.85 m. Height: 0.45 m.

This wall, which is bonded with the preceding walls has a solidly built socle of ashlar, on top of which a rubble wall is built. The S. end of the wall is formed as a door-jamb. Probably there is an entrance to another building which for economic reasons was never excavated.

Wall 122.

Width: 0.80—1.00 m.

This wall is built of rubble of ordinary size without mortar. The wall is founded on the solid rock with a sort of rough socle. It is parallel to the Walls 95 and 96, and makes a support for the *chavara* floor in Room XXIX. In front of the large staircase (165) up to Room XLIII, a worn ashlar is preserved on top of the rubble, evidently a threshold stone to a doorway through the wall. To the N. the wall runs for an uncertain distance. This part of the wall was never entirely excavated.

Wall 123.

Width: 0.55 m. Height: 1.60 m.

It is built of rounded rubble wedged with chips of limestone. In the core of the wall, only scanty gypsum mortar is noticed, but the faces are covered with a soft stucco revetment. The wall is founded on the rock. At the middle of the wall, there is, on the W. side, a semicircular apse built in the same technique as the wall. The apse wall is of the same width as the wall itself and is bonded with it as follows: to the lower part of the wall the apse is loosely added on the exterior of it; the upper part is bonded to the apse. The apse is filled with rubble. At the level 114.1 or 1.4 m. above the floor in Room LVII, a square flat limestone, measuring 0.58—0.64 m., was placed in the centre of the apse, the rounded edge of which projects a little from the wall face. To the N. of the apse, two other stone plaques project from the wall on the E. face. One of these is provided with two square cavities on the upper side (cf. Fig. 255). The meaning of these remains is uncertain.

The wall abuts against Walls 82 and 92. To the N., the wall is bonded with Wall 124, the joint being strengthened with some roughly cut limestones. (Figs. 255, 256, 265, and 266).

Wall 124.

Width: 0.50 m. Height: 1.30 m.

This wall is of the same type and construction as the preceding wall. It is, however, weaker and contains less mortar. A piece of the S. face near Wall 123 fell down, shortly



Fig. 253. Soli. Doorway through Wall 125 into Temple F.

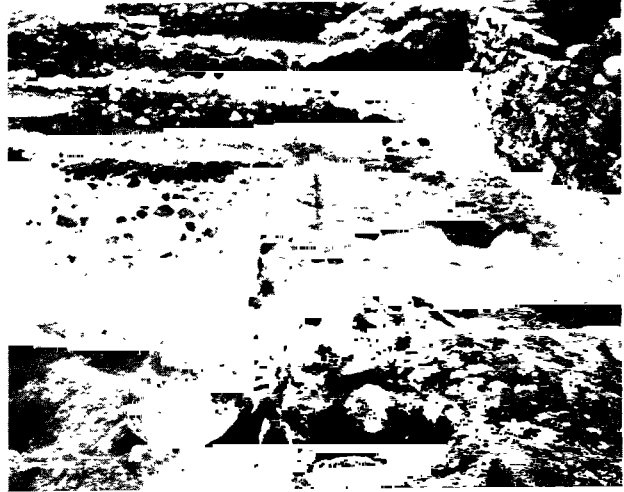

Fig. 254. Soli. Inner west corner of Temple F.

after its uncovering. The wall is founded on the rock and bonded with Wall 125. (Figs. 259, 265, and 266.)

Wall 125.

Width: 0.45 m. Height: 0.90 m.

It is of the same material and construction as the preceding walls and is bonded with the upper part of Wall 92. In the middle of the wall, there is a doorway on both sides flanked by large monolithic jambs. The threshold consists of flat stones at the level 103.0. The same arrangement as in Walls 72 and 73 is to be noticed here, *viz.* a long step inside the doorway provided with square pivot holes. The width of this entrance is 2.10 m. To the E. of it there is a passage between Walls 97 and 127. Here the floor consists of earth on a rubble foundation. This passage, which is 1.75 m. wide, was possibly connected with Room XXIX by some wooden steps. (Fig. 253).

Walls 126—127.

Width: 0.65; 0.90 m. Height: 0.75 m.

To the E. of Wall 125 there is a wide terrace limited on the S. side by Wall 97, on the N. and E. sides by Walls 126 and 127. Probably the terrace was the foundation for a tower, or the like in front of the doorway. The walls are closely connected with the present terrace, as a facing for it, which consists of rounded rubble. The walls are of the same construction as the preceding walls, but without any revetment. (Fig. 239).

Walls 128—132.

Width: 0.35—0.45 m. Height: 1.40 m.

These walls belong to an angled bench. They are all of similar construction, built of small rounded rubble without mortar and founded on the rock. The foundations of the wall below the floor-level of Room LIV are roughly built with projecting stones on the faces. The middle of the bench consists of *chavara*, which is held together by the walls. They are all bonded to each other. (Figs. 254, 259, and 266).



Fig. 255. Soli. Wall 123, eastern façade.



Fig. 256. Soli. Cistern 172 from the East.

Walls 133—139.

Width: 0.30—0.45 m Height: 1.00 m.

They belong to a similar bench of *chazara*, situated opposite the other one. These walls are of the same material and construction, and are arranged in the same way. Over the N. angle of the bench, however, a circular cistern is built, Cistern 172. (Figs. 259 and 265).

Wall 140.

Width: 0.45 m. Height: 0.40 m.

This wall is built of rounded rubble mixed with some oblong, roughly cut stones. It is built as a support for a terrace to the W. of it and is founded on a layer of earth. It abuts against Walls 123 and 22.

Wall 141.

Width: 0.38 m. Height: 0.40 m.

Another wall is built between Walls 22 and 124. It is of a very weak character, constructed of small rubble founded on the floor-level of Room XXVII.

Wall 142.

Width: 0.75—0.90 m. Height: 0.20 m.

This wall is built as a prolongation of the face of Walls 95—96—127 and connects these walls with the angle between Walls 21 and 22. It is constructed of rubble and is founded on the rock. The E. face is more carefully built than the W. one.

Wall 143.

Width: 0.75 m. Height: 0.75 m.

At the middle of Room XXVII there is a buttress built against Wall 22. It is founded on the floor-level of the room and consists of rounded rubble without mortar, the facing stones being of a larger size than the core of the wall.

Wall 144.

Width: 1.25 m. Height: 0.80 m.

This is another buttress to the same wall. It is of a similar construction as Wall 143 and bonded with Wall 142.

Altars.

Altar 145.

At the intersecting point of the axes of Room V, and Rooms I—II in front of the entrance to Room VII, there is a small, level floor cut out of the rock. In front of this rock-floor, there is a cavity sunk in the rock. As this cavity was filled with ashes, charcoal, and numerous fragments of terracotta statuettes (cf. below) it may be explained as an offertory pit. It is possible that an altar was once placed on the flat rock-floor near the cavity. Subsequently the altar, however, has been removed entirely.

Altar 146.

Width: 1.80 m.

East of the entrance to Room VIII there is an altar, shaped like a quarter of a circle. The altar consists partly of the solid rock, partly of white lime-rubble held together with hard gypsum mortar. The rounded rock-edge is vertically cut, and faced with small wedged rubble, covered with a gypsum revetment in many layers. Above this on the rock, there are the remains of the altar, which was built of rounded rubble and gypsum. Between the altar and Wall 24 A, there is a channel in the rock probably intended for the rain-water from the roof of Room X. (Fig. 225).

*Altar 147.*Width: 25.0 m. \times 22.0 m.

This altar is built of rounded rubble, wedged with chips and fragments of terracotta roof-tiles. The outside was covered with a partly preserved revetment of white, or yellow stucco. In the angles of the square altar, large orthostatic ashlar were placed as supports for the wall, which surrounds the edges of the altar. The core consists of a filling of rubble. At the northern angle of the altar, a fragment of a column of the same shape as those in Wall 44 and possibly that in Wall 88, is used as a building-stone. The western parts of the altar were probably destroyed by the digging of a trial trench. This happened to pass over this part of the altar. The very loosely built core of the altar could not be distinguished from the loose stones in the surrounding earth. The original shape of the altar, however, is indicated by a square, elevated part of the rock on which the altar was built. It was square in shape. In the middle of the eastern side, there was a small recess or niche, the floor of which was plastered with a square roof-tile. The northern jamb of this recess was built of fragments of roofing-tiles. The meaning of the recess remains uncertain. Possibly the place for the cult-statue was there.

Between the altar and the eastern Wall 7, there was a cavity in the floor about 0.25 m. wide, covered with a square roof-tile. The cavity contained grey earth and ashes. (Figs. 222 and 223).

Altar 148.

In the centre of the square courtyard, Room XVI, there are at the level 128.5 two well hewn ashlar built together on a foundation of rubble with gypsum mortar. The whole is founded on a layer of earth (the floor of the courtyard). Possibly these stones, evidently preserved *in situ*, are the remains of an altar in the centre of the courtyard. (Fig. 261).

Altar 149.

Width: 0.90 m.

In the northern angle of the Room XVIII there was an altar, now very much spoiled. A row of small rubble on the floor, held together with gypsum mortar shows the original size of the altar. Between these stones and the corner, the altar table proper was found. It consisted of a square stone plaque with slightly raised edges. On the walls above the plaque, there are no signs showing the original height of the altar. To the south of it there was a cavity in the rock 0.77 m. in diam., and 0.15 deep, filled with ashes and dark earth. This, too, should be connected with the altar.

In the western angle of the same Room XVIII, there is a small recess (cf. above), the walls of which are built of small rounded rubble. This recess was accessible through an opening in Wall 46. In the centre of the recess, there was an ashlar block with a square cavity in the centre possibly for a base of a statue.

Altar 150.

Width: 0.50 m. 0.65 m.

This altar is situated in Room XXXIV exactly in the middle of the western façade of Wall 69, against which it abuts. The core of the altar consists of comparatively large, white lime-rubble, which are covered with a gypsum revetment in two layers. The altar is built on the solid rock on a base of rectangular plan and with vertical, tapering sides. The upper part seems to be damaged. It is preserved, however, to exactly the same height as the lower part (A) of Wall 69. The core of the altar is not bonded with this wall, but the gypsum revetment of the lower part of the wall is the same as that of the altar and faced at the same time. (Fig. 247).

Altar 151.

Width: 1.60 m. Length: 4.30 m.

In the same room, another altar was built against Wall 68. This is, however, very much destroyed. The remains consist of two large ashlar blocks still *in situ*, on a foundation of small rubble and gypsum. Traces of other ashlars were to be seen on the foundation. The whole is founded on the rock. The ashlars are parallel to Wall 68. Evidently this altar formed a long bench extending along Wall 68. It was, however, not bonded with any of the adjoining Walls 67—69. Most probably this altar could be reconstructed as No. 155 in Room XXXV.

Altars 152 and 153.

East of Wall 103 are the remains of two altars oriented, as far as could be determined, in east-western direction. Their axes thus are slightly diverging from the other walls of the system. (Fig. 250).

Altar 152.

Width: 2.50 m. Length: 2.55 m.

It is the southernmost one. At present the remains of it consist of a square elevation of the rock-floor lined with small white lime-rubble, which are held together with gypsum mortar. The exact shape of the altar is uncertain, but according to the preserved remains it was square. On the western side, it seems to have been a small rampart built in the same way as the altar. The altar has, in a subsequent period been demolished, and built over by the Wall 107 and partly by the Altar 154.



Fig. 257. Soli. Offering pit of Altar 154, visible as a dark patch in the earth. The upper edge of the pit marks the floor-level of Room XLIII A.

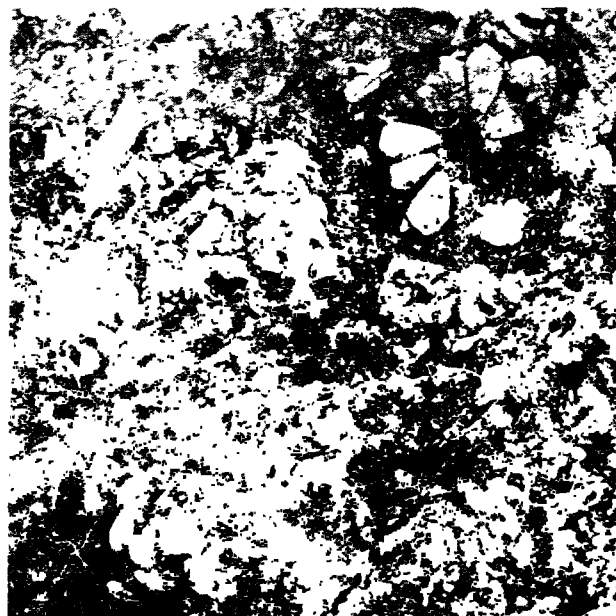

Fig. 258. Soli. Seeds of *Pinus Pinaea* in the offering pit of Altar 154.

Altar 153.

Width: 2.60 m. / 2.70 m.

This is too much destroyed to be described in detail.

Altar 154.

Reconstructed width: about 2.00 m.

This altar is situated between the two preceding altars and partly covering them. It has not the solid character as these and consists of rounded rubble blocks, built up without mortar into an altar which probably was square in shape. The southern and eastern parts, however, were destroyed. To this altar, too, a small rampart from the west belongs, built of somewhat larger rubble. Only one of the edges to this rampart is preserved.

The altar has an orientation diverging from that of the preceding altars but parallel to the axes of Walls 89, 107, 108, and 92. West of the altar there was a cavity in the earth-floor which was filled with cones of *Pinus Pinaea*. This cavity is to be connected with Altar 154. (Figs. 257 and 258).

Altar 155.

Width: 0.80 m. Length: 2.80 m.

This is situated in Room XXXV and forms a long bench along Wall 70. The altar is comparatively well preserved. It stands on a solid base, or socle of ashlar in two courses, which are laid on the rock-floor. The ashlar are held together with hard, white gypsum mortar. Above this socle, the altar consists of rubble which is faced with raised ashlar; the latter are provided with a carefully cut profile at the upper edge, which projects over the face. In the middle of the rubble core, there is a square part, elevated 0.37 m. above the ashlar level. The meaning of this is uncertain. Possibly it was the base for the cult-stature (No. 329), which was found slightly removed from this place on the altar. At the

northern end of the altar there is a small niche, 0.44 m. above the floor of Room XXXV between Walls 70—71 and the altar. It has a gypsum revetment. (Fig. 245; Plan XXXIX, 6).

Altar 156.

Width: 1.90 m. Length: 3.90 m.

Another ledge-shaped altar is to be found in Room XLV. The arrangement is similar to that in Room XXXV. Against Wall 88 there was a bench built with the upper edge at the level 122.0, or 0.55 m. above the floor of Room XLV. This level is the same as the highest part of Wall 67 A. The altar consists of a rubble wall built across the middle of the room. This wall which is founded on a layer of earth at the floor-level, retains the altar bench, the interior of which consists of earth-filling up to the level mentioned. The upper surface of the altar is covered with a layer of gypsum or stucco, which extends down over the wall mentioned, where it is provided with paintings of the same pattern as Wall 88 above the altar. Connected with this wide altar opposite the entrance of the room, there are two ledges along the sides of Walls 89 and 67. The side-ledges consist of rubble founded on the floor-level. These benches were also covered with a layer of stucco, painted on the façades of the interior of Room XLV. Their upper surfaces are on the same level. Thus only a comparatively small area of the floor remains in the centre and eastern part of the room. To the left and right of the entering worshipper are the side-benches; at the back of the room is the altar along Wall 88.

S t a i r s.

Stair 157.

Width: 1.35 m.

This leads up through Wall 17. No steps are preserved *in situ*. Only the foundations of the staircase are now to be seen. They consist of rounded rubble held together with white gypsum mortar on which traces of the stair ashlar are noticeable. The edgestones are larger, and roughly cut. The foundations of this staircase rest partly on the solid rock, partly they are built on the filling of an earlier tomb destroyed before the construction of the staircase. The same tomb has been built over by the Wall 21. (Fig. 229).

Stair 158.

Width: 2.50 m.

It leads up to a doorway through the Wall 7. All the stair ashlars have been removed so that only some remains of the foundations of the stairs are now to be seen. These consist of gypsum mortar on a raised part of the solid rock, just to the east of Wall 7.

In close connexion with the staircase, there is a wall which at a subsequent period, has been built in front of Walls 7 and 19 (cf. above). This wall has probably been attached, in connexion with some later alterations of the original stairs. A reconstruction of the staircase is rather difficult from these very scanty remains. Probably, however, four steps would lead up to the level of the threshold-stone preserved in Wall 7. (Fig. 222).



Fig. 259. Soli. Interior of Temple F, west portion from the South.

Stair 159.

Width: 0.45 m. Length: 1.20 m.

This consists of three large ashlar. The largest one is placed between the two others so that the approach is from two sides. The ashlar which are placed on the rock are held together with white gypsum. The staircase is built against the Wall 13. (Fig. 225).

Stair 160.

Against the eastern façade of Wall 25, there was a staircase leading up from the south to the doorway in the Wall 25. The staircase consists of a foundation of small rubble held together with gypsum mortar. This foundation which extended along the whole of Wall 25 is covered on the outside with a gypsum revetment of the same kind as that of Wall 26. A part of the foundation has been destroyed just in front of the doorway. Only the lowest step is preserved *in situ*. It consists of a slightly worn ashlar.

Stair 161.

Width: 1.50 m.

This stair is built against Wall 11. It consists of a rubble-stone foundation built on the solid rock. The rubble is held together with hard gypsum mortar. Only the lowest

step, very much worn, and a fragment of the second, are preserved. These consist of long ashlar. The rest of the steps had been removed. They can, however, be calculated to have been five in number. (Fig. 262).

Stair 162.

Width: 0.90 m.

In front of the doorway through Wall 48 there are two steps leading up to the threshold. The steps which consist of two flat stones are placed on a small rubble-foundation on the solid rock. At the southern end of the uppermost step, there is a square pivot hole. (Fig. 231).

Stair 163.

Width: 4.60 m.

Leading up to a doorway through Wall 79 there is a flight of steps, the remains of which are now to be seen west of, and below Stair 165. They consist of a row of ashlar solidly built on the rock with gypsum mortar, against Wall 79. The two southernmost ashlar are preserved *in situ*. The others have been removed a trifle, but their original places are easy to state. The northern ashlar had been removed, but the original width of the step can be calculated from the traces of the removed ashlar on the rock, and the gypsum mortar which was left. The edge of the step thus could be defined to a point 2.20 m. from the angle between Walls 79 and 80 (cf. also the description of Wall 79).

Another part of the same staircase is visible to the east of Wall 84, on the southern side of the great Staircase 165. Here two ashlar of another step in the staircase are preserved, built against the Wall 84. They extend below Staircase 165. These ashlar are on a line with the southern end of the step described above. The centre of the staircase had been destroyed at the building of Stair 165 and Walls 90 and 91, which were founded on the rock.

Stair 164.

Width: 5.20 m.

Concerning this, see the description of Wall 74.

Stair 165.

Width: 2.70 m.

This staircase is built between the Walls 90-91 and 95-96. It leads up from Room XXIX to Room XLIII. The foundations of the stairs consist of two parallel rubble-walls in west-east direction, which are bonded with Walls 95 and 96, on both sides of the steps. The ashlar of those have been removed, so that only the rubble-core of the foundation is now preserved. On this, however, every one of the eight steps is distinguishable. The side walls of the staircase are built on the solid rock of rounded rubble without mortar. The interior edges (towards the steps) of the walls are strengthened by somewhat larger stones. At the western ends of the walls, there are square, solidly built pillars containing gypsum mortar. Inside these pillars are two short buttresses for the uppermost step. They, too, contain gypsum mortar. The foundations for the steps are built of rounded rubble, the larger of which are placed at the edges of the steps. No mortar can be observed here. (Figs. 221 and 263).

Stair 166.

Width: 1.45 m.

This staircase is situated in the southern angle of Room LIV and leads from the floor of that room up to the floor of Room XLIII C. It consists of a rubble-stone foundation

and 4 steps of ashlar. Another 2—3 steps would have been necessary to reach the level mentioned. The foundation consists of rubble of ordinary size held together with white gypsum mortar. This foundation is constructed partly on loose earth. Each step consists of 3—4 ashlar held together with white mortar. In the two upper steps, the edge stones are missing. The whole construction abuts against the Walls 92 and 125. (Figs. 239 and 253).

Water-conduit and cisterns.

Water-conduit 167.

Old villagers from Galini report that this conduit could be seen some years ago at various points higher up in the hills, but nowhere are these remains preserved now. The conduit appears in the area excavated to the south-west of Walls 86 and 55. It runs here parallel to the walls mentioned, and further down along the Wall 68 where the conduit is interrupted by Cistern 168 (cf. below). The conduit is moulded of cement and is shaped as a channel with carefully worked edges. The channel measures 0.20 m. in depth and width. Most certainly, it was covered with flat stones throughout its length. These stones are preserved north of Cistern 168. Here the conduit turns to the east between Walls 50 and 70, and follows Wall 52 where it is bonded with the revetment of that wall. This part of the conduit is founded on a layer of earth. The conduit passes through Wall 22. Evidently the conduit was built at the same time as this wall. North of the wall, the conduit turns to the east and follows the wall mentioned down to Cistern 169. The easternmost part of the conduit is damaged. On that part of the conduit which runs along Wall 22, most of the covering stones are missing. (Figs. 241 and 262).

Cistern 168.

Width: 0.55 m. Length: 1.10 m.

It is, like the conduit, built of cement in a cavity in the rock. It is of a slightly irregular, rectangular shape with rounded angles. The outlet of the cistern is placed below the channel on the southern side of the cistern. This small cistern cannot possibly serve any other purpose, than that of clearing the water before it runs into the temple-area.

Cistern 169.

Width: 1.30 m. Length: 1.60 m.

The water-conduit ends in a rectangular cistern inside the angle between the Walls 21 and 22. This is built of rubble and flat stones against the walls mentioned. The interior of the cistern is covered with a thick layer of cement rather well preserved. The upper part of the cistern is damaged and missing. Probably the conduit ran into the cistern at the north-western angle. The outlet is situated close to the south-eastern angle just above the bottom; it consists of a circular terracotta pipe which runs through the wall of the cistern and Wall 21. It runs into —

Cistern 170.

Width: 1.75 m. Length: 1.80 m.

This is of the same material and construction as the preceding one. The interior angles are smoothed. Approximately 0.75 m. of the walls are preserved, but the upper parts are

destroyed. Possibly they extended up to the same height as Cistern 169. The water-pipe from that cistern runs out just above the bottom of Cistern 170. The outlet of the cistern is situated, like in Cistern 169, in the southern angle near the bottom. (Fig. 234).

Cistern 171.

Diam: 0.85 m.

In Room XXII there is a cylindrical well cut in the solid rock to an uncertain depth. The edges are lined with rubble, sometimes held together with gypsum mortar. The well was closed by a square ashlar, just big enough to cover the centre of the hole. The well was filled with earth, to a level 5 m. below the covering ashlar. It was never excavated entirely, because of the bad smell which made work near the well almost impossible. (Fig. 236).

Cistern 172.

Diam: 1.15 m.

This cistern is built together with Walls 133 and 139, against the angle between Walls 123 and 124. The cistern is of circular shape with slightly concave bottom. The sides are built of rubble, which are covered with a layer of stucco. The upper parts of the cistern are destroyed. Possibly there was an outlet to the south-east. Here the side opens into a channel which runs down to the angle between the Walls 135 and 136, and further to a *pithos* which was sunk into the floor of Room LIV. (Fig. 256).

STRATIFICATION

Before we proceed to the description of the stratification proper some remarks will be made as to the nature of the solid rock on which many of the walls are founded. This is of a very soft consistency and crumbles easily. The nature of the rock makes it very suitable for cutting. Within the area excavated several chamber tombs were discovered which had been partly destroyed by the constructions built above them. On the other hand the surface of the rock had been defaced purposely in order to make space for the constructions mentioned. In general the surface of the rock slopes from the north to the south but straight through the middle of the area a valley or bay had been excavated in the solid rock possibly because just in this part, the rock was of too loose consistency to be a good basis for the buildings. This deeper part, artificially made, extends from Wall 54 in the west to Wall 122 in the east, the sides being bounded by Walls 92 and 22.

On another spot the rock had been cut away purposely in the extreme eastern part of the area along a line roughly marked by Walls 67—75—76—78. Probably, east of this line the rock was not suitable as base for the constructions. On various occasions minor cuttings in the rock were noted which partly had been placed in furrows in the rock or, more often, as a lining to the edge of it.

The loose rock, called by the peasants *chavara*, obtained as a product of these cuttings was on many occasions used for flooring rooms or courtyards. In this way the whole of Room XXIX had been laid out with such *chavara* stuff. The floor of this room thus had

the structure of a real terrace retained by Wall 122. Due to these transformations of the original rock surface, the bottom of the excavation was reached at very different depths. The area occupied by Rooms XXXI—XXXV thus is like a higher plateau between the areas on either side of it. Furthermore, the gradually sloping rock between Walls 5 and 21 is interrupted by a large cavity in the rock below the middle of Room II, which most likely is due to the chamber tombs, which, on this spot were destroyed when the floor of Room II was levelled.

Concerning the general character of the debris it may be said that the layers were of various composition if they were situated below floors, walls etc., *viz.* if they in any way were connected with the buildings proper. These layers will be described in detail on the following pages. The earth which was covering the destroyed buildings, however, was rather homogeneous in consistency. It was grey in colour and contained plenty of stones fallen from the walls and a small amount of pottery. The fallen stones were concentrated at certain continuous layers which usually started at the present summits of the walls. Close to the floors this filling sometimes changed and objects found in the bottom stratum on the floors evidently should be connected with the constructions. Other finds between the floors or underneath them are to a great extent used for the establishment of the chronology.

In order to facilitate the investigation of the stratification the following seventeen sections are separately described. They are laid out on the most important places, the discussion of which otherwise would be very difficult and inconvenient to follow:

Section I (Plan XXXV, 1).

This section shows the layers in Rooms VIII, X, and XX and their relations to Walls 19, 23, and 25. Wall 19 is founded on the rock at level 128.0 and is levelled off at 140.0. The rock slopes slightly towards the south and has been levelled for the floors of Rooms X and XX. In the middle of the section Wall 23 is founded on the rock at level 122.0 and further to the south the threshold stone in Wall 25 is seen with its upper side at 123.8. The surface also slopes to the south. In Room VIII, an almost horizontal stratum (5) is found close to the rock. It consists of debris, pieces of plaster, roofing-tiles and pottery mixed with hard clay. The upper side of the layer is stamped into a real floor at level 128.0—129.5. The filling above this floor consisted of grey, rather dark earth (2), and the surface layer (1). In Room X similar conditions are recognized, only with the difference that most of the room was filled with fallen stones from the surrounding walls (3); the same layer continued also below the threshold, in Room XX. As the eastern part of the floor in Room X slopes, it was filled up with white gypsum (4).

Section II (Plan XXXV, 2).

The layers have not changed much in this section which is laid out about 5 m. south of Section I, and almost parallel with the same. The layers in connexion with Stairs 158 and 159 are demonstrated. The rock is slanting from the north to the south and appears in the section with a highest level of 135.0—138.5 (floor of Room V) and with a lowest level of

114.5 (below Stair 159). Layers 1 and 2 are of similar consistency as in Section I. In Room V, however, and partly extending outside the entrance through Wall 7 and Stair 158, a layer was found, consisting of rubble of various size mixed with pieces of plaster, the whole being very hard and substantial. In this layer (3) the sculptures found in this room were lying close on the floor, many of them embedded in gypsum plaster, others among the looser stones which had fallen from the walls. A quite similar layer was recognized above Stair 159, there too, mixed with sculptures. Evidently this layer had slid into position on the sloping floor of Room III from Room V. Most likely the sculptures found close to Stair 159 once had stood in Room V together with the others found there. In the eastern part of the section the offering pit of Altar 145 is seen with a lower level of 114.0.

Section III (Plan XXXV, 3).

This section shows the rather complicated conditions below Rooms XVI, XXIII, and XXIV. The section is divided into three different portions by Walls 52 and 64. We start with the western portion *i. e.* the layers in and below Room XVI. Below the surface layer (1) and the usual layer of grey earth (2), there is a layer of fallen stones (3) of the surrounding Walls 53 and 54. This rests on a *chavara* floor at level 124.0 (4) which is thicker close to Wall 52. Below the floor the earth changes entirely and here, a layer (5) of brown, sandy earth is met with, which rests on top of Wall 51. At the same level, Wall 52 is founded partly on top of Wall 51. At this level (118.5) a second floor is noted, clearly distinguished near Wall 51, but of somewhat looser consistency further to the west. The layer below the floor (6) is rather dark in colour and mixed with sand. Wall 51 is founded on another layer (7), the upper portion of which is met with at level 112.0. Still further down loose *chavara* (8) was found at level 108.0. With the exception of the last layer, plenty of pottery sherds were found in all the others, a fact of importance for the chronology, as the layers, evidently, are undisturbed.

East of Wall 52 the conditions are less complicated. Below the two surface layers a heavy strip of stones is noted in the section, mainly coming from Wall 52 (9). These fallen stones cover the whole area of Rooms XXIII—XXIV. Below them a layer of grey earth is noted, similar to Layer 2 (10). At level 118.5, a floor was found in connexion with the Water-conduit 167. This floor (12) had partly been cut through contemporary with the construction of Wall 64. The pit or ditch into which the wall was founded was filled with rather loose stuff (11). For technical reasons the excavation could not be brought further down without removing the water-conduit. East of Wall 64 the floor of Room XXIII is noted (15) laid out at level 113.0. The floor consisted of hard clay and extends between Walls 64 and 66. Above it, some fallen stones from Wall 64 are noted close to this wall (14). The rest of the filling on this floor consisted of grey earth of the same character as Layer 10 (13). The floor was laid out on a substructure of sandy brown earth (17) and rubble mixed with loose earth (18). The rubble is possibly explained as stones fallen from Walls 56 and 57 which belong to a construction of earlier date than Room XXIII. The floor of this construction was found at level 101.5 (19) and consisted of very solid dark clay, which extended down

Section I

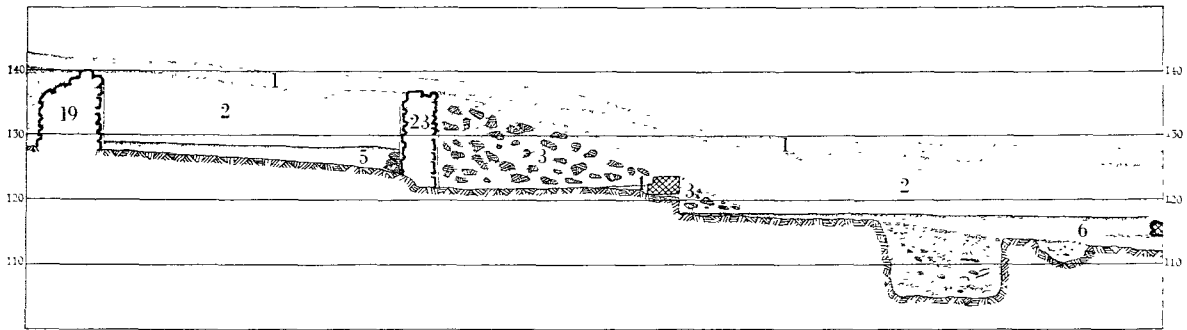

1

Section II

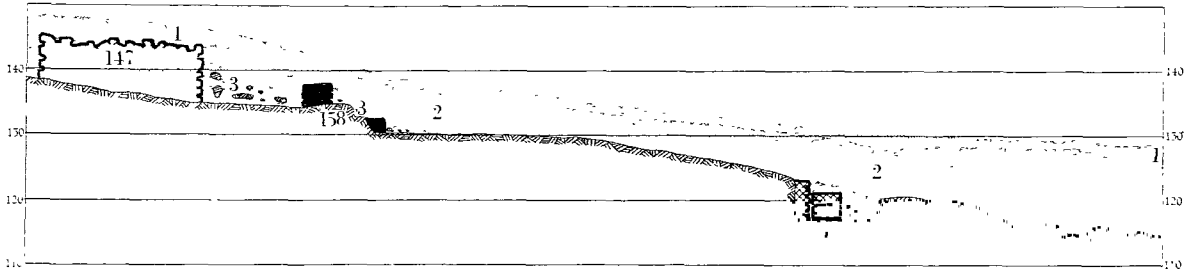

2

Section III

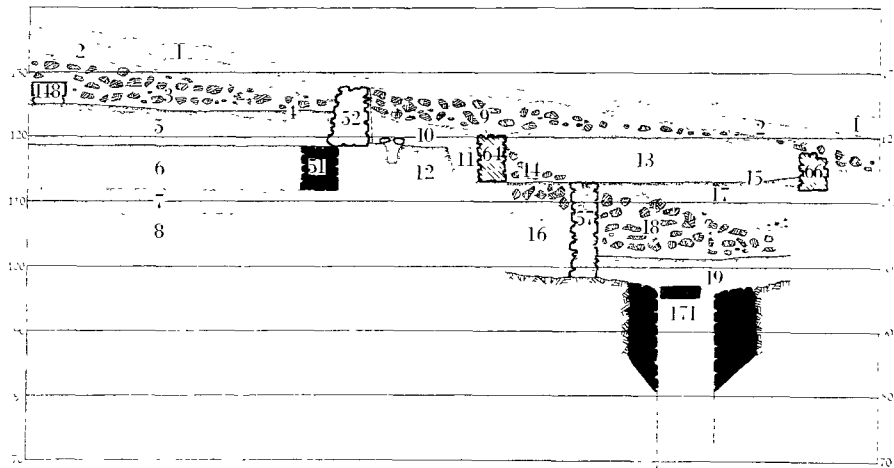

3

Section IV

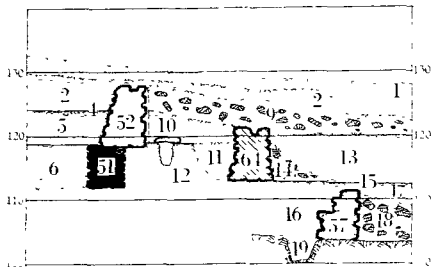

4

Section V

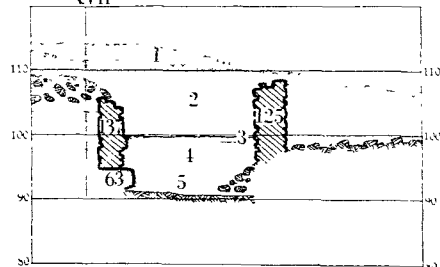

5

to the rock. Below the middle of Room XXII, the well (171) was found excavated in the rock. It was blocked by a square slab, and empty down to 5 m. from the entrance. (cf. above). Summing up the most interesting facts as to this section, it may again be pointed out that two separate courses of constructions were found in either part of the section, one above the other. But the constructions and floors of the western part seem not to have any direct connexion with those of the eastern part.

Section IV (Plan XXXV, 4).

This shows a similar stratification as in Section III. The same layers and walls are cut through and, therefore, they are numbered as in Section III. Section IV, however, is placed some metres to the south so that the space between Walls 64 and 57 can be studied. Below the floor of Room XXIII (15) Wall 57 appears with a rather rough face to the west outside of which was a filling (15) consisting of hard, brown debris. Apparently this face constitutes the exterior of the construction. Just below this face, there is a cavity in the rock, a water-conduit, running outside the wall, in direction towards the well mentioned above (171). This conduit serves the purpose of preventing water silting into Room XXI through the wall. The conduit was filled with hard clay of the same consistency as Layer 19 of Section III.

Section V (Plan XXXV, 5).

Between Walls 125 and 137 it is possible to state where the floor of Room LIV is situated. The elevation of this floor and the layers below it are demonstrated by Section V. Below the surface layer (1) and the filling in Room LIV (2), the floor of that room was distinguished as a thin strip of plaster (3) at level 100.0. This level is clearly marked, too, on the face of Wall 137. Below the floor another layer of brown earth (4) is noted which extended to about level 95.0 where a layer of very hard earth mixed with rubble was met with (5). On the same layer Wall 125 is founded while Wall 137 is founded on an ashlar block which belongs to Wall 63. Evidently, Layer 5 constitutes the filling of the wall-system 63—59 etc., and thus must be of earlier date than the superimposed construction for the floor (3) of Room LIV. The rock was discovered just above level 90.5.

Section VI (Plan XXXVI, 1).

This section shows the stratification in Rooms XXXV and XLIV. Below the usual two surface layers (1 and 2) follows a layer of stones fallen from the surrounding walls. In this layer (3) some fragments of sculpture were found. They may be explained as building-stones as they evidently had been used for the walls and fixed there by means of mortar and plaster which still was attached to the sculptures. Besides, some sculpture fragments were found *in situ* built into the walls together with the rubble blocks. The earth below Layer 3 must belong to this very occasion: the rooms gradually were filled with sand and earth before the walls fell into ruins covering the floor stratum (4). This consisted of brown sandy earth in which pottery fragments and some other small objects were found. This is the case as

Section VII

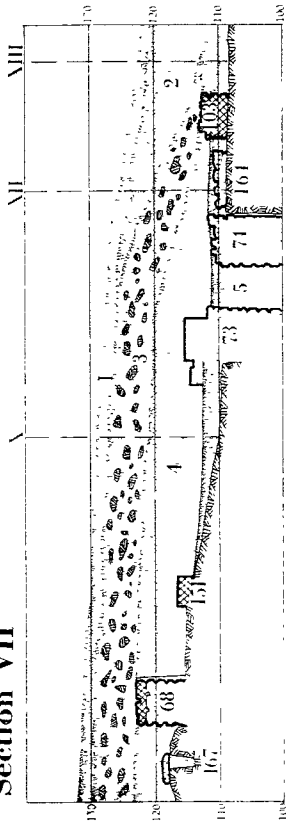

2

Section IX

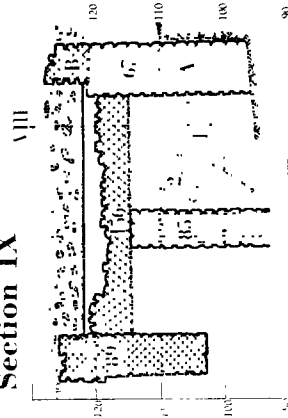

4

Section XI

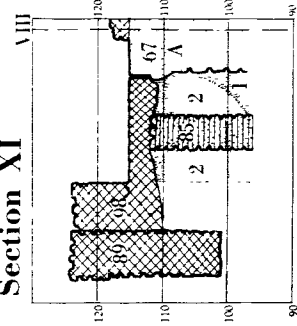

6

Section VI

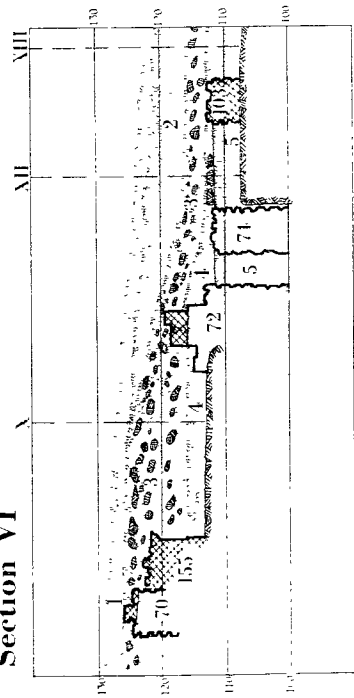

1

Section VIII

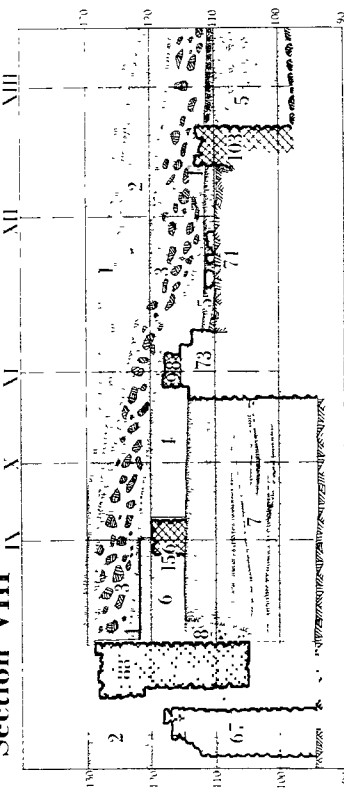

3

Section X

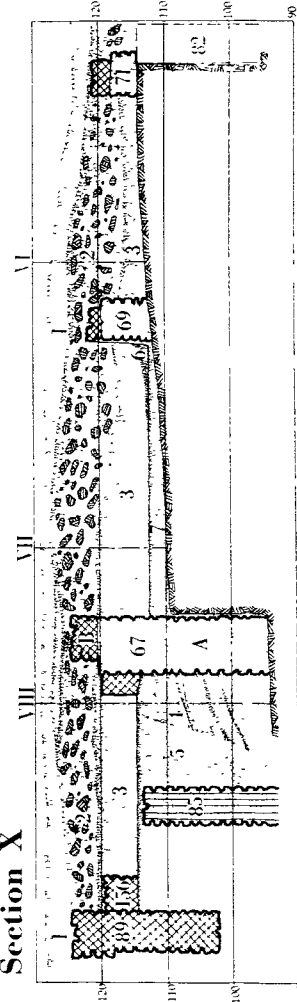

5

regards Room XXXV. In Room XLIV, however, a kind of substructure for a floor was discovered at level 113.0. Below this the earth was rather dark and here the terracotta lamp, No. 349, and some sculpture fragments (No. 336) were found which thus must be of earlier date than the floor constructed above the filling. The solid rock was found at a depth of 107.5. Between Walls 72 and 74 the earth-filling extended down to a depth of 100.0 where loose *chavara* was met with. Because of the narrow space, the excavation could not be carried deeper.

Section VII (Plan XXXVI, 2).

This section runs through Rooms XXXIV and XXXIII and shows a stratification very similar to that of Section VI. Layer 2 comes up almost to the surface layer. Here, too, Layer 3 contained fragments of sculptures among the fallen stones. Other sculptures were found in Layer 4 on the floor of Room XXXIV and outside the entrance through Wall 73. While Wall 103 and Stair 164 were founded on the rock-floor, Walls 74 and 73 are sunk down into a deep depression which could not be excavated to the bottom, as the shaft was too narrow. Between the walls mentioned, a real floor of hard, plasterlike concrete was found at level 111.0. This was recognized on patches above Wall 74, too. Below the floor, Layer 5 was excavated to a depth of 100.0.

Section VIII (Plan XXXVI, 3).

The stratification of Rooms XXXIV and XXXV are very much alike, as the floors of these rooms are placed on or very near the rock. Room XLV is a later addition to the side of the rooms mentioned and is, therefore, different to those in many places. Section VIII shows the stratification close to Wall 67 in Room XLV, and the layers outside the entrance in this room. The two surface layers are of the same kind as in the previous sections and also the heavy layer of fallen stones (3) which is found all through the whole section. Here, however, it may be noted that no pieces of sculptures were found among the stones. Evidently no sculptures had been re-used as building-stones in the walls of Room XLV. Next below Layer 3, a layer of brown earth mixed with pieces of plaster was found (4), as well on the altar (156) and the floor of the room, as on the floor of Room XXXIII outside the entrance. Wall 103 extends down to an indeterminable depth facing the rock of Room XXXIII. East of the wall mentioned, at level 111.0 a floor could be determined, laid out on a substructure of small rubble blocks. The floor was placed on a very hard stratum of dark, brown earth with horizontal courses of lighter strips (5). This was dug through to a depth of 98.0 where a second floor of rubble was met with. The upper floor, however, could be followed further to the east in Room XLIIIA, but there, no rubble blocks were found. Only a thin layer of hard earth constituted the floor, probably because the solid rock here is met with on a much higher level. In the other direction, too, the floor could be followed above the rock below Room XXXIII. Below the floor of Room XLV, the layer could not be found, due to the narrow space for excavation. Layer 7 extended partly below Altar 156 which was built up of earth (6) supported by a rubble wall. Layer 7 had been dug through

at the same time as Wall 88 was constructed and the pit on the east side had been filled with *chavara* (8).

Section IX (Plan XXXVI, 4).

This is a short section which is laid straight through the rear wall of Altar 156 from Wall 89 to Wall 67. The strata above the floor of Room XLV are similar to those of the previous section. The upper surface of the altar is seen at level 122.0; the floor of Room XLV at level 115.0. The floor rests immediately on top of Wall 85 which has been levelled off to give place for the room. Close to Wall 67 the filling which consists of *chavara* and strips of plaster has horizontal courses (1). These, however, have been cut through by a ditch in which Wall 85 was placed. The ditch is filled with other *chavara* (2). This shows that Wall 85 must have been built later than the lower part of Wall 67. The stratification to the south of Wall 85 could not be studied in this locality, as there was practically no place to go down with a deep shaft.

Section X (Plan XXXVI, 5).

This section shows the stratification in all the Rooms XXXIV, XXXV, and XLV, which have been cut through by Sections VI—VIII. The walls and the architecture may first be mentioned. As is seen, Rooms XXXIV and XXXV are situated on a comparatively high plateau of the solid rock. The edge of this is faced by walls, to the south by 67 to the north by 82, the latter, however, partly removed. The walls of Room XXXV (69 and 71 B) are founded on top of the rock plateau. The south wall of Room XLV (89) is founded in the debris at level 102.0 and below the floor of the same room, Wall 85 is noted levelled off just so as to give place for the floor. The side-benches of Altar 156 are visible attached to Walls 67 and 89. They are founded on debris at the same level as the floor of the room. The upper additions of Walls 67 and 69 are clearly visible on the section. Furthermore, a small lining of Wall 71 B is visible on the outside. Once it was partly based on Wall 82.

As to the various strata, they are more or less described under the previous sections. Below the surface layer (1) the heavy line of fallen stones is recognized all over the section (2). Below this, the filling on the floors was found (3). Close to Wall 69 on the floor of Room XXXIV a layer of ash (6) was found containing Finds 326 a—c. In the same room the uneven rock had been levelled by means of a horizontal floor, consisting of a filling of hard clay and pieces of plaster (7). In Room XLV the conditions are different. Here the floor was laid out at about the same level as in Rooms XXXIV and XXXV, but on the debris. Below the floor the original filling outside Wall 67 was found with somewhat oblique courses (4). In this filling a shaft had been dug for Wall 85. The filling of the shaft (5) consisted of *chavara*. Probably the level 93.0 constitutes the bottom with the real rock which, however, here is so soft that it hardly is to be distinguished from the *chavara* above.

Section XI (Plan XXXVI, 6).

This section should be considered as a mere architectural one and shows the circumstances in connexion with the threshold of Room XLV and the joint of the buttress of Wall 67

and Wall 98. The layers above the threshold are omitted. The buttress of Wall 67 is very solidly constructed and was followed down into the debris as deep as was possible (about level 97.0). Against the upper part of this buttress the threshold is built and founded in the debris at the comparatively high level of 111.0. The threshold is partly resting on Wall 85, several times mentioned in the descriptions of the previous sections. As to the stratification there is nothing new. The original filling outside the buttress is distinguished (1) as well as the ditch (2) excavated in it in connexion with the construction of Wall 85.

Section XII (Plan XXXVII, 1).

With Section XI we leave the three Rooms XXXIV, XXXV, XLV and procede to the stratification in front of them. This is already partly made in Sections VI—VIII. Section XII crosses them and is laid out in order to demonstrate the whole stratification between Walls 89 and 92 on the area west of Wall 103. As to the architectural remains visible in the section, the Stair 164 is noted in the middle. It was not founded on the rock but in the debris just above it. On either side of this stair, the lower step of which is seen on the section, Walls 75—85—99—89 and 105—106—92—82 are situated. While Wall 92 is founded on the rock Walls 105 and 106 are founded in the debris at a level which may indicate a floor (level 111.5). On the other side Walls 75 and 85 are levelled off to about the same elevation. The depth of Walls 99 and 89 were not ascertained on this part of the excavation. As to the stratification most of the layers are known from Sections VI and VIII. Below the two surface layers (1 and 2) follows a layer of fallen stones (3) which, evidently to a great extent, originate from the thick Walls 89 and 92. The slip-stone layer gradually disappears above the Stair 164. Below this layer, follows another one consisting of brown, sandy earth (4). At level 111.5 a horizontal line was noted between Wall 105 and the stair. This most likely marks a floor-level though the earth below (5) showed no variation to Layer 4. The rock was found at level 108.0.

Section XIII (Plan XXXVII, 2).

Just east of Wall 103 the conditions have not changed very much though there are layers and walls which deserve some explanation. The section is parallel to Section XII and, as in that section, is limited by Walls 89 and 92. In the middle, Walls 107 and 108 are distinguished. They are founded in the debris somewhat above the level of the solid rock. Below Wall 107 the rock slopes rapidly and there, Wall 76 is noted probably founded on the rock at a deep level. The space between Walls 76 and 89 is occupied by a floor based on a substructure of wooden beams, the impressions of which are clearly distinguished in the soil. The beams were covered with a revetment of plaster which was preserved *in situ* (Wall 101). The two surface layers (1 and 2) are known from the previous sections and also the layers of (3) which fallen stones come from Walls 89 and 92. Below the fallen stones there is a layer of brown, sandy earth (4) corresponding to Layer 4 in Section XII. The same holds good for Layer 5, separated from Layer 4 by some faint traces of a floor at level 111.0. The floor, however, could be noted only close to Wall 107. For the stratification below Walls 101 and 102 reference is given to Section XIV.

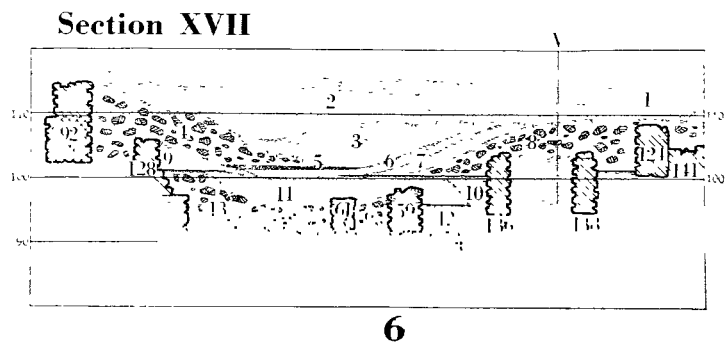
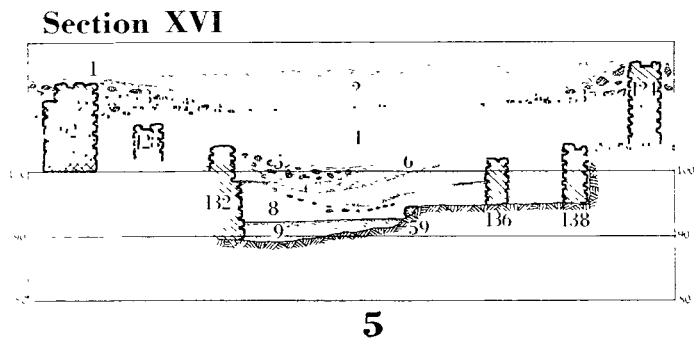
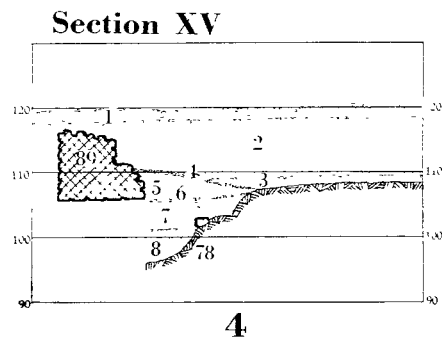
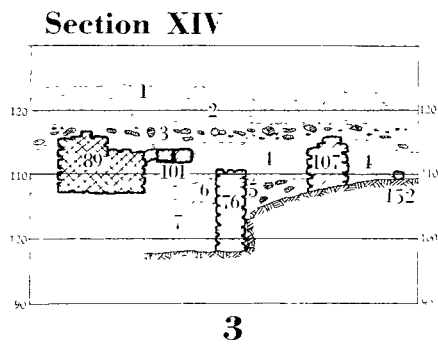
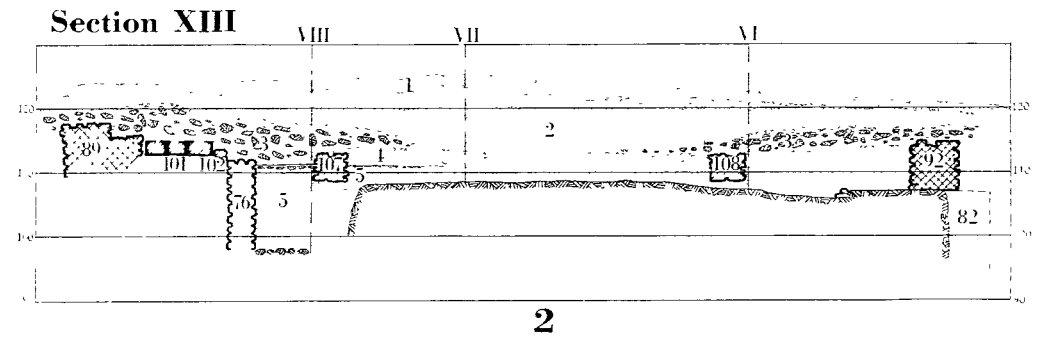
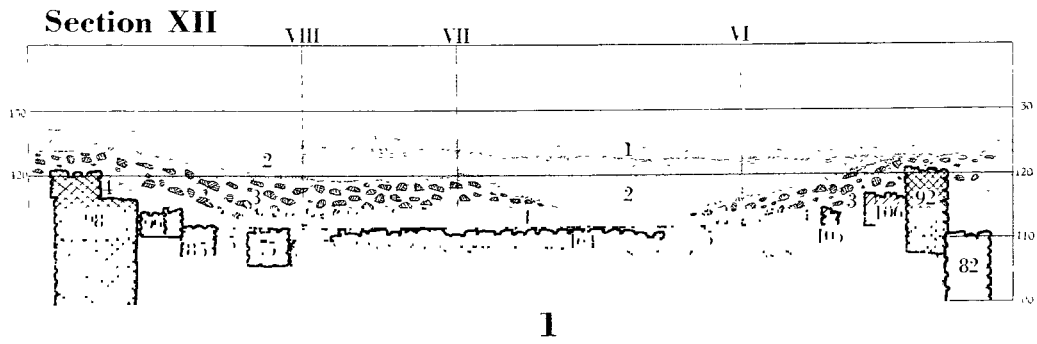

Section XIV (Plan XXXVII, 3).

This is a short section the meaning of which is to show the stratification in connexion with the floor based on Walls 101 and 102. In the middle of the section, Wall 76 is recognized, founded on the solid rock in a depression of it. On either side are Wall 107 of loose construction and founded on the rock, and Wall 89 founded in the debris at level 107.0. Below the two surface layers (1 and 2) and the fallen stone layer (3) a layer of grey earth follows (4). Between Walls 107 and 76 this rests on another layer (5) consisting of brown sandy earth and retained by Wall 76. Below the wooden beams with their plaster impressions, a filling of light-brown, sandy earth (6) was found which rested on thin courses of gypsum matter visible in the section as oblique strips. As an important fact it may be mentioned that these strips always pointed to the base of Wall 89 which shows that they constitute the surface level of the debris on which the wall was founded. Below the strips, a quite different kind of debris was found, dark in colour and containing plenty of pottery sherds (7). The chronological sequence of the layers and the walls must be explained as follows:

1. Wall 76 was built as a facing to the rock edge to the north of it. Possibly Layer 5 accumulated at the same time.
2. On the floor of Room XL the debris, Layer 7, accumulated and on top of those, Wall 89 was founded.
3. Subsequently, Layer 7 was heightened with Layer 6 and on top of this the wooden floor was laid out.
4. When the construction later on slowly began to fall into pieces, Layers 4—1 gradually accumulated on top of the walls and earlier strata.

Section XV (Plan XXXVII, 4).

This section corresponds to the previous one but is laid outside Room XL. The stratification, however, has not changed much. Wall 76 is continued by Wall 78 which was built as a facing of the rock edge. Wall 89 appears in a similar way as in Section XIV. As to the upper layers it may be noted that the fallen stones have disappeared so that Layer 2, consisting of grey earth, comes down close to the floor-level (4). Layer 3 consists of dark, sandy earth and Layer 4 of *chavara*. Evidently this constitutes the floor of Room XLIII B which belongs to Wall 89. This wall is founded in the debris at level 106.0, which is marked by a thin layer of *chavara* (6). Layers 4 and 6, both consisting of *chavara* meet at level 108.0 slightly below the floor-level for Room XLIII B. Between them there is a wedge-shaped layer (5) composed of brown earth mixed with *chavara*. Below Layer 6 a dark, sandy earth was found (7) which extended down to level 101.0 where it rested on a horizontal layer of pure *chavara*, which did not contain a single potsherd. The chronological order of the strata and the walls is explained as follows: — the *chavara* stratum (8) originally constituted the ground on which Wall 78 partly was built. This wall being destroyed, the debris of Layer 7 was laid as a filling on which Wall 89 was founded. This level was marked by the thin layer of *chavara* (6). The rough lower part of Wall 89 shows that Layer 6 cannot have been the floor of Room XLIII B. The filling was heightened, up to Layer 4 which was intended as a continuation of the rock-floor at level 108.0. Layer 3 probably was in position already,

during the time the building was still in use, while Layers 1—2 should be explained as originating from its period of destruction.

Section XVI (Plan XXXVII, 5).

For a long time, during the excavation, the stratification of Room LIV was very puzzling. The centre of the room could not be excavated until a road on which the railway was laid had been removed. Until nearly all the debris had been removed, the same problem occupied the excavators' mind: to find the floor-level of the room and to keep in contact with the very faint traces of it. As usual in these temples, there was no real pavement, not even a real layer indicating the floor. Probably owing to the sloping character of the rock below, the previous floor-level had sunk down, following the slope of the rock. This holds good, especially concerning the interior of the room. Towards the entrance, the floor was more even and there, too, it was not so difficult to trace. Section XVI is laid across the interior part of the room while Section XVII is meant to show the layers near the entrance. The section is confined by the long walls of Room LIV, Walls 92 and 124. At a distance of about 0.60 m. inside of these, there are benches of *chavara* filling retained by thin shells of rubble walls, 128 and 132 to the south, 138 and 136 to the north. Obviously the upper parts of these benches were destroyed. A line of projecting rubble blocks on the face of Walls 132, 131, 135, and 136 at level 99.0 seemed to indicate that a floor was laid at this level. At a much deeper level, Wall 59 runs parallel with the long walls of the room. All the walls in the section are founded on the solid rock. Below the two surface layers (1 and 2) two wedge-shaped layers of stones fallen from Wall 124 and 92 follow. The two layers (3) nearly meet in the middle of the section. Below the fallen stones follows a layer of grey earth containing single potsherds. At level 103.0 the stratification begins to show more complicated features. Close to Wall 132, there is a short strip of brown earth mixed with small rubble and pieces of plaster (5). This rests partly on top of another layer consisting of a compact substance of burnt clay mixed with plenty of plaster (6). Both these layers rest on a heavy streak of charcoal and ash (7) lying obliquely across the whole centre of the room. The Layers 5—7 may be explained as the roof of the building which burnt and fell down upon the floor. Evidently the roof was constructed of wood and sealed with plaster and clay. The final catastrophe of the building might explain the difficulty of finding the floor, which must have been laid on the next layer (8) composed of a filling of brown earth and rubble. Layer 9, consisting of pure *chavara* filling, most likely forms the floor of Room L the extent of which is ascertained only to the north (Wall 59). Summing up the facts we obtain the following chronological order of the strata: when Room L was constructed the *chavara* filling (9) was laid as a floor for that room. Subsequently this building decayed and Room LIV was constructed above it. Its walls and benches were founded on the rock. Room L was covered with the filling (8) and the new floor placed on top of the filling. Later on the house burnt, the roof constructed of wood, clay, and plaster fell down on the floor thus causing the accumulation of Layers 6—7. The top layers all came into position in connexion with the general destruction of the building.

Section XVII (Plan XXXVII, 6).

Quite a similar development can be traced in this section which is laid parallel to the previous one, but nearer the entrance of the rooms. Walls 92 and 124 are easily distinguished as also the northern bench with the *chavara* filling. In the middle of the section, Walls 59 and 61 are noted, founded on the rock. In this section the floor of Room LIV is easily ascertained. It is laid on the filling of Layers 10 and 11. Layers 1—9 are thus all foreign to the building, or constitute matter removed from its original place. The two surface layers are of the usual kind. Layer 3 has not the hard consistency of Layer 2. The stones of Layer 4 have evidently come from Wall 92, while the loose *chavara* (9) below Layer 4 originates on the southern bench. Layer 5 consists of charcoal and ash and corresponds to Layer 7 of Section XVI. It may be noted that the carbonized matter of Layer 5 does not rest immediately on top of the filling below the floor (11) but on a layer of *chavara* (6) which has silted down from above the northern *chavara* bench. This rests on other layers (7 and 8) originating from the same direction. Below the floor-level of Room LIV, there is a compact filling of brown debris (11) into which a pit had been dug. The northern *chavara* bench was founded on the bottom of this pit. The pit had partly spoilt a second floor at level 96.0 which evidently belonged to the wall-system below the floor of Room LIV (Room LIII). This second floor consisted of pebble laid out on a bed of hard, brown sand containing plenty of pottery (12). South of Walls 59 and 61, there is a bottom stratum composed of hard clay and plenty of rubble (13), evidently the remains of the destroyed surrounding walls. Between Walls 138 and 124 there is a narrow passage where the floor easily could be distinguished. The floor stratum (14) consisted of hard clay mixed with plaster.

ARCHITECTURAL ANALYSIS

Walls 5—8 are bonded to one another making together a closed room which, by the bond-stones of Wall 6, is bonded only with Wall 9 which on the W. encloses a court in front of Room V. The S. limits of the court must have been constituted by Wall 10 B, which is also a revetment wall for the edge of the rock in the court just mentioned. Towards the S., this ground is bounded by Wall 11 and Wall 12, both of them being built as a basis for the floor of the aforesaid ground. Between Walls 12 A and 12 B there seems to have existed a corner, for which reason it is supposed that Wall 12 B has continued in W. direction towards the N. E. corner of Room V in this way limiting the court. Careful excavations between Wall 12 B and Wall 19 only, made it appear that a previously existing wall there might have been taken away. The ground thus enclosed, accordingly, has a curved, irregular form, but its floor is constituted by the rock, cut evenly and slightly sloping towards the E. This ground may be explained as an open court in front of the temple *cella* (Room V) which was covered with a roof. The entrance to this court lies in front and on axis with the entrance to the *cella*.

E. of the entrance of the court between Walls 11 and 12 A, the conditions are very complicated. Here the rock-floor shows considerable cavities of irregular shape, which are remains



Fig. 260. Soli. Western portion of Temples B and C, seen from the North.



Fig. 261. Soli. Temple C from the South. Walls 10 and 53 uncovered below the floor of Room XVI.

of rock-tombs and which, probably in connexion with the later buildings upon the ground, have been entirely demolished and filled up. Whether Walls 1-4 constitute remains of buildings, or are only substructures for a floor, placed at a higher level, is uncertain. They lack direct connexion, however, with the other walls within the excavated ground from which they differ also in location.

Within the ground enclosed by Walls 11-12, 20-22, two different layers are to be distinguished: a lower one with Walls 14-18 and an upper one with Walls 20-22, and 26-33. The walls in these separate layers differ also in location, so that the walls of the lower layer extend in E. W. and N. S. direction respectively, while the upper walls are oriented in more N. W. and S. E. direction.

Hence, it appears evident, that there are two separate buildings, belonging to different periods. The walls of the lower layer (14-18) diverging from those of the upper one, enclose a rectangular ground (Room II), which, on the E., was accessible by the Stair 157. Excepting a short distance between Walls 17 and 18, all these walls are bonded with each other, and, accordingly, must belong to the same period of building. The W. parts of Walls 14 and 18, however, are destroyed and broken off, for which reason the boundary to the W. of the rectangular area cannot be stated for the present.

Walls 19-22 are bonded with each other and therefore must be contemporaneous. To the same building period must also be assigned the Water-conduit 167 and the Basins 169 and 170, since they are bonded with these walls. These enclose another rectangular space of considerably larger surface, Rooms VI, XIX, and XX, within which Walls 26-28, 29-37 are situated and orientated along the above mentioned walls. As Wall 26 is built against Wall 20 and partly hides its painted stucco covering, this wall ought to be a later addition. As Walls 27 and 28 are bonded with Wall 26 and together with this form a wall-conduit, these too must belong to a subsequent period in relation to Wall 20. Concerning Walls 29-33, it has already been shown in the description, that they form a support for a line of columns. They are partly built upon the ruined Wall 14, and must therefore belong to a period when this had ceased to fill its original function. The other line of bases 34-37, is parallel with Wall 20. The bases have no direct connexion with other walls, and as they are within the ground enclosed by Walls 14-18, one might think that they belong to their period but this is not the case. The fact is that the walls have a floor which, at least in certain places, it has been possible to point out. Another floor-level has been observed above the preceding one belonging to the upper wall-system. As the bases, which are of a supporting character, are situated between the two floor-levels it must be supposed that they belong to the upper and later system. Their place in this system will be explained below. Concerning the walls of Room X, several epochs can be pointed out. The N. wall is constituted by a part of Wall 20. Also Wall 23 seems to have been constructed (cf. p. 426) in connexion with the building of this wall, it being covered inside with the same sort of finishing coat as Wall 20. As this finishing coat continues behind Wall 24 A the latter wall seems to be an enlargement subsequently added. Yet Wall 24 A is on the N. E. side covered with plaster, which is partly hidden by Wall 24 B wherefore this seems to belong to a further additional enlarge-

ment. Walls 23 and 24 B have hereby been provided with painting in the same pattern. As to Wall 25, it is bonded with Wall 24 A, and consequently must belong to the same period as this. The wall-pier in the N. W. corner will surely belong to the same period, as similar piers form parts of Walls 24 A and 25 in remaining corners of Room X. These walls thus, together with Walls 23 and 20, came to form Room X, whereby Stair 160 was necessary to connect the room with the ground E. of it. As the substructure of this stair in the N. part is bonded with Wall 26, Walls 26—28 seem to be constructed at the same time as Walls 24 A and 25. In line with the first mentioned wall also, lie the column-bases Nos. 34—37 for which reason these, too, must be assigned to the same, or a later period. Probably also the Altar No. 146 belongs to this building-period, as its form, evidently, has been determined with regard to the existence of Wall 24 A. The outer edge of the altar is bonded with Wall 13, and consequently the whole section (Wall 13 with Stair 159) may be ascribed to the same time.

N. of Wall 8 Room XII is added. As its walls abut against Wall 8 and as its floor lies on a relatively high level this part to a certainty, must be an addition to Room V. It may possibly belong to the same building-period as Wall 24 A and the Altar 146, as the same cement mortar is used on these places but is not met with elsewhere excepting in a portion of Wall 21, where we may have to do with an accidental repair from the aforementioned time.

Within the ground south of Room V, enclosed by Walls 45—52, two quite separate layers with two different floor-levels are to be distinguished. The lower of these layers is sunk in a cavity in the rock, the edges of which are supported by Walls 10 and 54. Of Wall 10, its lower part 10 A is bonded with Wall 54 and partly with Wall 51, while its upper part abuts against Wall 52 which is built above Wall 51, and belongs to the top layer. Hence it follows that at least part 10 A of the wall may belong to the bottom layer. As Wall 53 is bonded with Wall 54 as well as with Wall 51, this wall too must be assigned to the lower layer. Consequently a whole room (XV) has been enclosed by four walls belonging to the lower layer with a floor at level 112.0. One more room situated south of it may have been contemporary with Room XV, but of this only a part to the north is preserved (Room XIV).

The walls of the top layer are easy to distinguish. They are all bonded with one another, excepting Wall 48, which for other reasons must be put in the same period. Walls 45—49 and the west part of 50 have all the inside covered with the same sort of plaster. This is, however, lacking on Wall 50 east part, and on Wall 52 which fact is easily accounted for, because these walls function as supports of a court-terrace and, accordingly, have had their inside under ground. The part that has been above the upper floor-level is not preserved.

The development of the alterations made in this part of the excavated ground has been as follows:

In a cavity in the rock, a block of rooms is formed, to which belong Walls 10, 51, 53, and 54 and with a floor-level at 112.0. This block of rooms is later demolished, levelled, and filled up to a level corresponding with the level of the rock north and west of the rooms or 125.0. Upon this level another somewhat sloping floor is planned, limited by Walls 45,



Fig. 262. Soli. In front, Stair 161 leading to the courtyard, Room XVI; above, Stair 162 leading to the *cella* of Temple C. To the right, the *cella* of Temple B.

48—50, and 52, and in connexion with this, on the west, Room XVIII is constructed. To carry out this work, the levelling of Wall 9 and Wall 10 B to the same level is found necessary. The limit between the earlier described space south of Room IV (Room XIV and Room XV), and the one now treated is then removed about 3.50 m. to the north, to Wall 45. This measure seems to have been occasioned by the desire of getting accommodation for a direct passage between Room XIX and Room XVI. This want is provided for of Stair 161, which in this connexion, is built against Wall 11 partly concealing its plaster-covering on the E. face. 2.5 m. E. of Walls 48 and 49 are two bases of columns placed symmetrically.

South-east of the now described area is another space in the angle between Walls 51—52, and 22. Here, too, two different layers are to be observed. At the bottom of the rock, which is situated at the level 98.0, the wall-system 56—58 was found. The walls with the floor at the level 102.0 are remains of blocks of rooms completely demolished, and in subsequent times reduced to the level 105.5 where a second earthen floor was found. On the same level are also founded walls which belong to this floor (Walls 64—66). This block of rooms forms the architecture of the top layer within this space, and shows a rectangular room with the entrance through Wall 22.

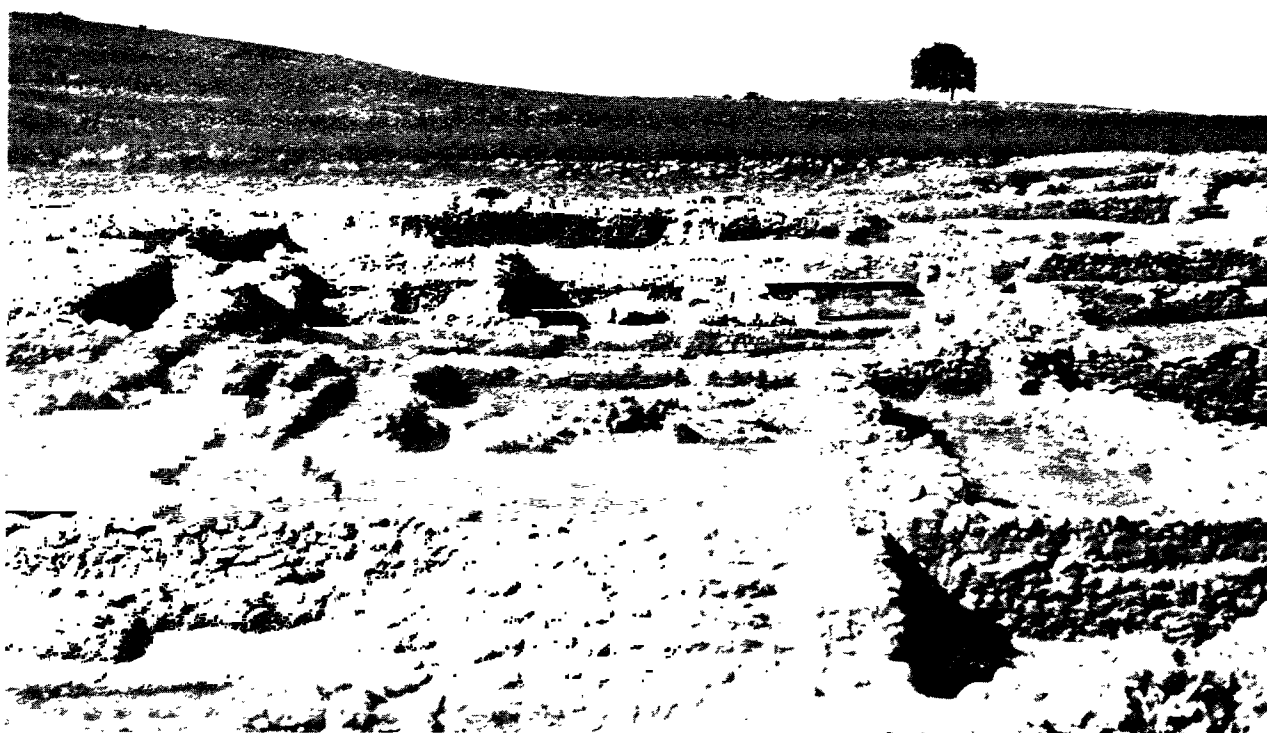

Fig. 263. Soli. General view of Temple E, from the East.



Fig. 264. Soli. General view of Temple E, from the West.

In the description of the walls, it has already been established that Walls 67 - 73 consist of two clearly distinguishable parts: a lower part founded on the rock, and a narrower one built upon the former. These walls enclose the two rooms XXXIV and XXXV. A corresponding division into a lower layer of walls and an upper one can also be perceived to the south and east of these rooms. The walls in question are not bonded with other walls. On the contrary Walls 88 and 98 abut upon Wall 67. These walls, in their turn are connected with Wall 89 which to the south bounds a space situated east of Rooms XXXIV and XXXV. Their limit on the north is constituted by Wall 92, which is of the same construction as Wall 89, and on the east by Walls 90—91. Walls 88—92, consequently, belong to a common building to which also can be referred Walls 93—97, symmetrically built on both sides of Stair 165 and bonded with this and Walls 89 and 92. Walls 89—92 have all on the inner face a break, marking the floor-level of Room XLIII between Walls 89—92. This floor-level marks the level of the upper layer. Under this level, another system of walls was found resting on the rock, the upper level of which has been cut down to the upper floor-level which slopes to the east.

These walls are Walls 74—82 with Stairs 163 and 164; further Walls 83—87. Among these walls, Nos. 78—81 are coherent, and of the same character, in consequence of which they must have been built contemporaneously. The direct continuity between Walls 81 and 82, is for technical reasons impossible to point out, as subsequent alterations have destroyed the real corner of the walls. It will, however, be clear from the following that Wall 82 must also belong to the same building.

Wall 78 abuts on Wall-corner 76—77, and has its direct continuation in Wall 76, which, consequently, ought to have replaced the western portion of Wall 78; it has thus entered the same building as the just named Walls 78—82. The space here enclosed is then bounded on the north-east and south. Its limit to the west seems to be constituted by Wall 74, which also belongs to the bottom layer of the walls. This wall disappears below Wall 92, and, to a certainty has been bonded with Wall 82. On the other hand, Wall 74 by means of a couple of buttresses is connected with the lower parts of the system of Walls 67—73. We consequently find that in front of the two Rooms XXXIV and XXXV lies an irregular, but mainly rectangular space bounded on all sides by walls belonging to the bottom layer of the walls within this part of the excavation. To the same building also, Walls 83—84 may be referred, as being orientated in agreement with Wall 79. They limit Room XXX situated E. of the rectangular space in question and have been built over by Walls 90—91 and Stair 165. The remaining walls belonging to the bottom layer, are Walls 85—87. They are built in two stages, as appears from the description of the walls. They have been levelled just to the upper floor-level and overbuilt by Walls 88, 89, 98, and others of the upper level.

These walls probably constitute the north parts of a building, the rest of which was not examined, and which extends to the south of the investigated territory. Possibly this building is connected with the block of rooms formed by Walls 76—77 at the foundation of which the west part of the original Wall 78 has been demolished, and the connexion between this and Wall 74, lost.

We go on to the walls of the top layer which in the clearest manner differ from those of the bottom layer in the south-west part. Here Wall 88 abuts against Wall 67, which is partly built over by this wall. Wall 88 is, in its turn, bonded with Wall 89, which through bonds and otherwise is connected with Walls 90—97 and the Stair 165. These walls enclose on three sides, a symmetrical building which moreover is limited on the west by Rooms XXXIV and XXXV.

In these circumstances, Walls 88—97 must be put with the upper parts of Walls 67—73, as brought about in one single connexion. Apart from the walls of the bottom layer, we obtain a closed building of the following appearance: on the west, three closed rooms beside one another, the middlemost one being of a somewhat larger size. To the east of these three rooms, is a rectangular space or court bounded by Walls 89—92, and further to the east of this the two Rooms XLI and XLII built symmetrically on either side of the large Stair 165, on the middle axis of the building bounded by the thick, solid Walls 94—97.

We now turn to the large, central space examining, still without taking into consideration the walls of the bottom layer, the system of walls, which is here distinguished: — Parallel to Walls 72—73, 98 runs Wall 103. It is bonded with no other wall. It rests on the rock unlike all the other walls which abut against it, and which are placed on debris. Symmetrically and in the prolongation of the wall lie on both sides Walls 100 and 104, the former connecting Wall 103 with Wall 89, the latter with Wall 92. These three walls, consequently, extend across the rectangular room parallel to Walls 72—73, 98. At right angles to Wall 103 run, towards the east, Walls 107 and 108 which are parallel to each other. In connexion with this system of walls are also Walls 105 and 106 abutting against Wall 104. All these walls can be divided into two kinds: on one side Wall 103, placed on the rock, on the other side, the remaining walls, which, in spite of being situated near the rock, are founded on debris. This fact seems to indicate that we have to do with two different periods; for if Wall 103 and Wall 104 were constructed at the same time, they ought to have been built without interruption of the bond and with the same construction. Then Wall 103 must be the original one, against which the others were built at a later time. Wall 103, however, must have been founded later than Wall 74 and the Stair 164, or else it would have blocked up the whole stair. To the group of the upper walls also belong Walls 99, 101, and 102, of which the last two are placed on loose earth.

Walls 109—113 form together with Wall 89, a closed room built on a comparatively high level. Also Walls 117—121 form together a closed unit, loosely connected with the remaining blocks of rooms by Walls 114—116.

Another closed space is bounded by Walls 123—125 being bonded with each other and built against Wall 92. These walls enclose a rectangular ground within which two different layers of walls are to be observed, separated by a floor at level 101.0.

The walls belonging to the lower system have all been levelled off for this floor and, consequently, they must be ascribed to an earlier period than the walls of the upper system. Only fragments of the lower walls are preserved and what remains is not sufficient for any



Fig. 265 Soli. View of the interior of Temple F, from the East. The floor of Room LIV is removed so that Walls 59—63 are visible.

certain conclusions. Wall 59, however, is aligned with Wall 58 mentioned above and therefore should be considered as a continuation of this and belonging to the same building. As the solid rock within the area between Walls 92 and 22 is found on a much lower level than on either side of them, this building cannot have extended much further outside the present Rooms LIV—LVI. The western limit of the building seems to be at Wall 57. Too small parts of Rooms L—LIII are preserved for exact determinations of the rooms. The system of walls belonging to the floor at level 101.0 shows a much better state of preservation. The exterior Walls 123—125 are all founded on the solid rock. Inside the walls, there are two angular benches running parallel to the walls of the rectangular room. The benches are constructed with thin shells of rubble with a filling of *chavara*. At the northern corner of the room, Cistern 172 is joined to the northern bench. At the southern corner, the Stair 166 connects the floor of Room LIV at level 101.0 with the floor of Room XLIII C at level 109.0. The room is accessible from the east by means of an entrance through a short corridor. The axially and symmetry of this room is apparent. It is still more accentuated by the apse in Wall 123, which faces the entrance through Wall 125.

The connexion between Room LIV and Room XLIII can be studied at two points:



Fig. 266. Soli. Western portions of Temples F (in the foreground) and E (in the background) seen from the N. E.

Wall 123 abuts against Wall 92; on the other hand Wall 125 is partly built on top of Wall 92, in a way which seems to show that the entire corner between Walls 92—91—125 and the eastern portion of Wall 92 was repaired contemporaneously with the building of the construction enclosed by Walls 123—125. In any case this construction must be of a later date than Room XLIII. This is confirmed by the conditions in connexion with the entrance to Room LIV. This entrance has evidently been laid out in consideration of the extension of Room XLII and Wall 97, which at the same time forms the south wall of the corridor in front of the entrance.

ARCHITECTURAL SYNTHESIS

In taking into consideration the architectural remains of the various building periods, we leave out structures connected with the tombs excavated in the rock in the north-eastern part of the area investigated. These walls can in no way be ascribed to any of the other constructions and the remains of the walls are so fragmentary that nothing can be ascertained as to the nature of the structure to which they belonged.

P e r i o d 1.

Temple A. The plan of the first construction can be explained as follows: A rectangular courtyard (Room II) was entered from the east by means of Stair 157 and the small vestibule (Room I). The western parts of the side-walls of this rectangular courtyard are not preserved, having been demolished in connexion with subsequent alterations on the plan. No doubt the walls once extended as far as Walls 11 and 12 A and were connected with them. The gate through the walls mentioned leads up to a higher terrace on which another courtyard is situated. This is irregular in shape and was well defined by walls on all sides, two of them being removed subsequently. Into this courtyard (Rooms III and IV) a square building projects at the north corner, thus giving the courtyard an angular form. The building (Room V) is entered from the south-east by means of a stair (158). As the finds made here prove that the whole construction must be a temple, we thus find a temple-*cella* (Room V) which opens on to an upper courtyard (Room III). East of this, there is a second courtyard on a lower level. Near the middle of the lower courtyard there was probably an altar raised on the axis of the court and facing the entrance. Whether or not there was an altar in the *cella* during this period, remains uncertain, for the altar marked on the plan must be ascribed to a later period. The west-east orientation of the lower courtyard may be noted. The upper courtyard with the *cella* diverges slightly from this axis.

On a much lower level, there was an other structure south of the upper courtyard (Rooms XIV and XV). Due to the conditions of bonds etc., this building, though not constructed on the solid rock, must be of contemporary date to the building described above. The complete extent of the building cannot be ascertained, nor can it be stated whether it was connected with the courtyard Room IV, by means of a stair. The walls of the two rooms had probably been destroyed purposely when the house was filled in, at a later period.

P e r i o d 2.

Temple B. In a subsequent period the whole of this area was entirely rebuilt. In general the system of the first construction was adopted when planning the new building. But the lower courtyard was enlarged and the upper one was altered as to its extent. The *cella* (Room V) remained as before the alterations, and there are no signs of destruction or rebuildings. The construction south of the upper courtyard was filled in, and a new temple was constructed above it, partly built in with the other new construction. The particulars of the alterations were as follows: the whole of the lower courtyard (Rooms I and II) was filled in and its boundary walls levelled to the floor of the new courtyard. The boundary walls of this were placed outside the old ones so that the new court became considerably larger. The orientation of the new courtyard is more or less brought into line with that of the *cella* (Room V), though the walls diverge slightly. The entrance into the courtyard is from the east, but is not in the middle of the wall; it is placed to the south, so that it is on the same axis as the *cella* entrance, and the gate between the two courtyards. Obviously

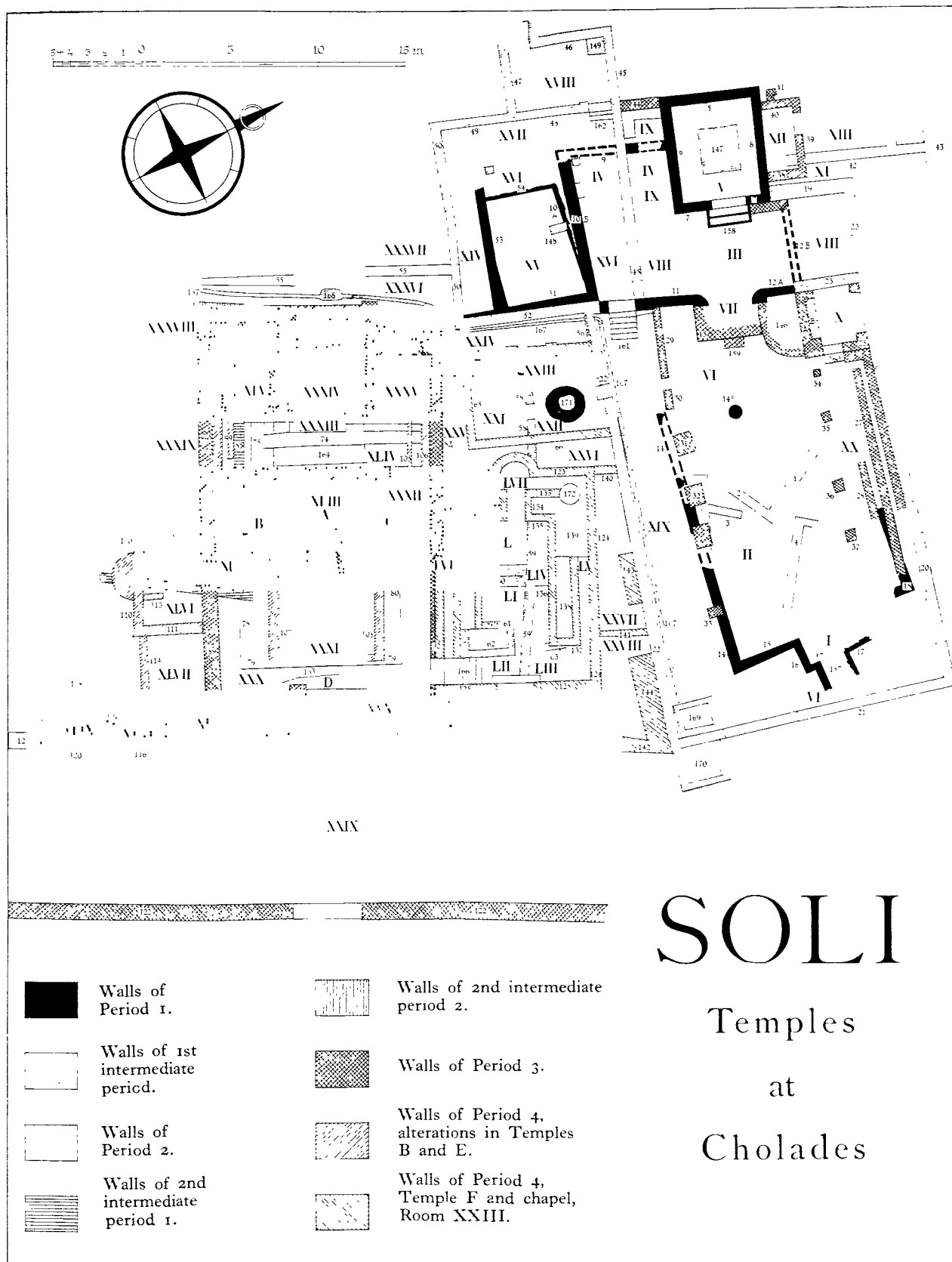

Fig. 267. Soli. Analytical plan of the temples.

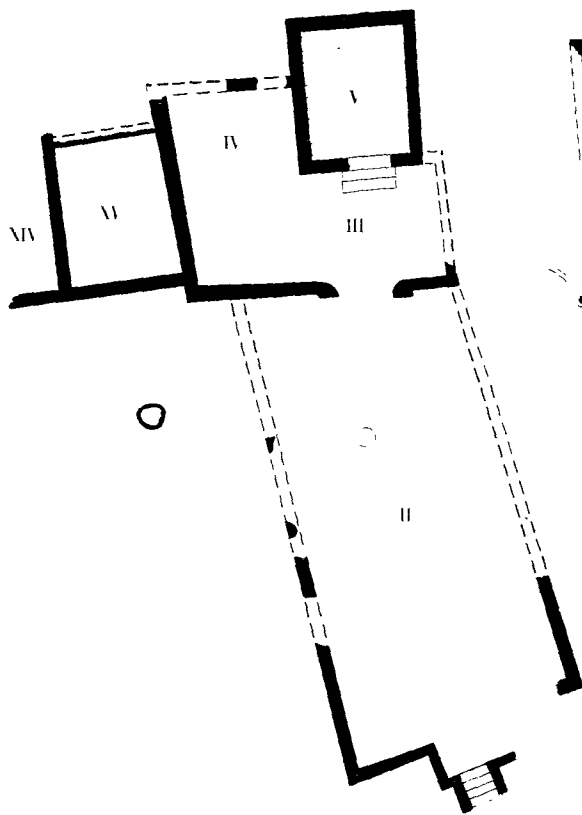

Fig. 268. Soli. Plan of Temple A (Period 1).

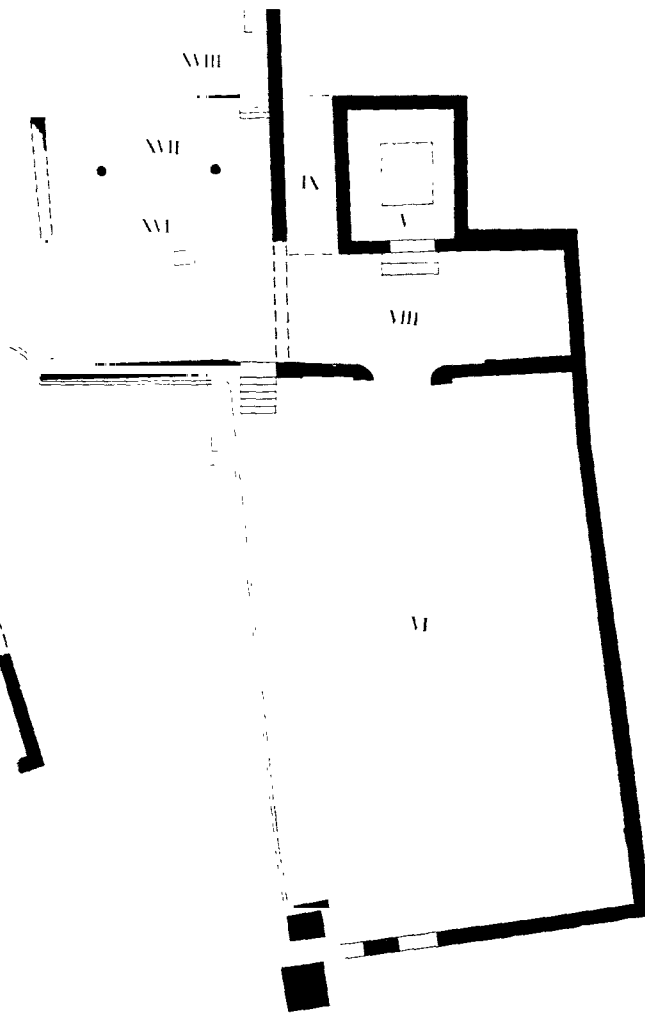

Fig. 269. Soli. Original plan of Temples B and C (Period 2).

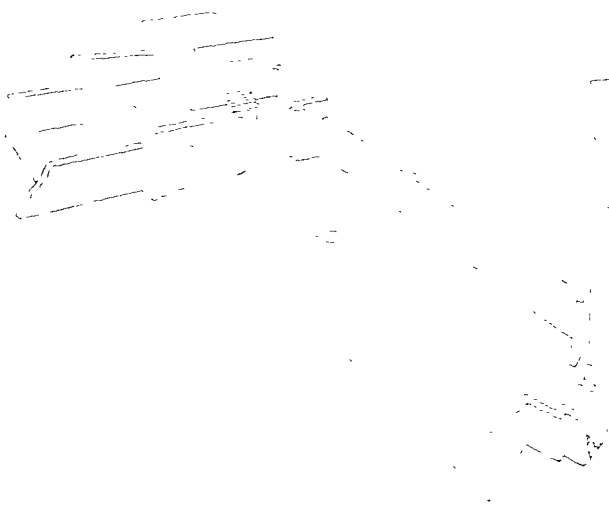

Fig. 270. Soli. Reconstructed sketch of Temple A (Period 1).

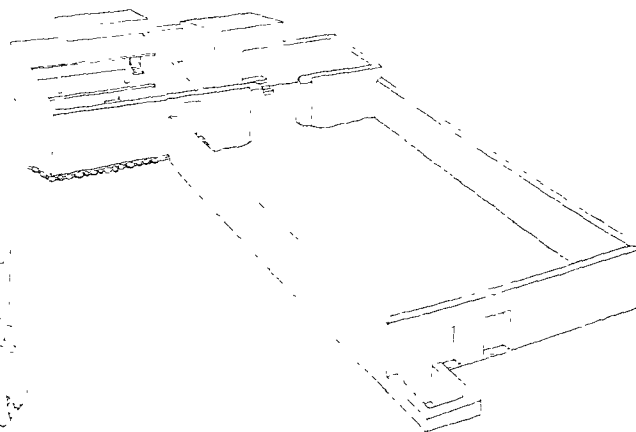

Fig. 271. Soli. Reconstructed sketch of Temples B and C (Period 2).

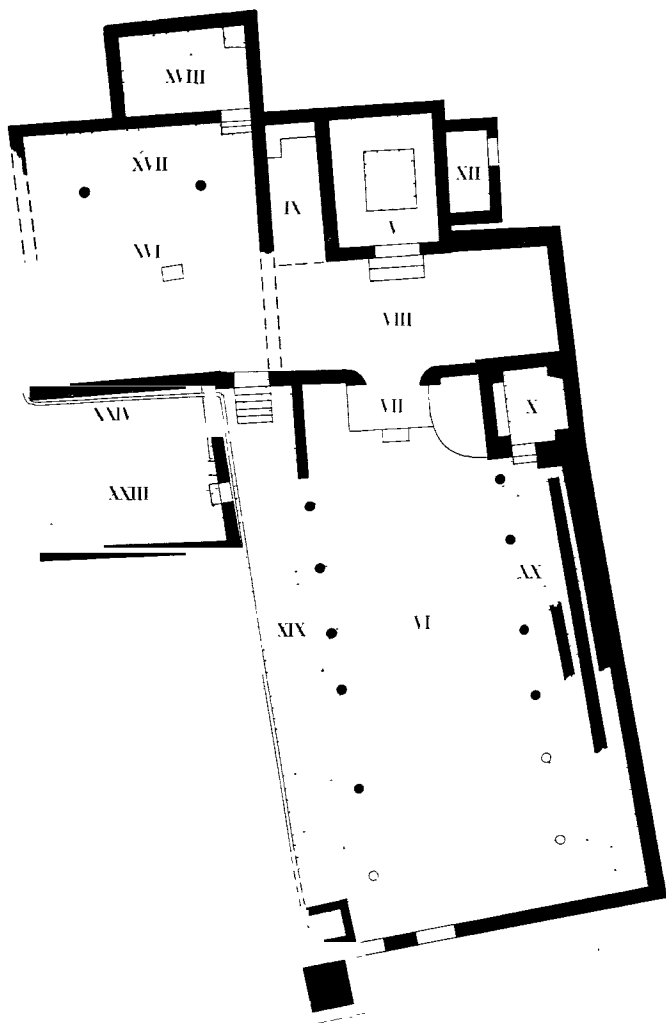

Fig. 272. Soli. Altered plan of Temples B and C (Period 4?).

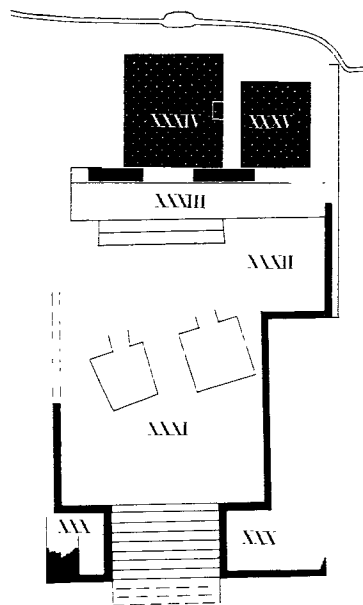

Fig. 273. Soli. Plan of Temple D (Period 2).

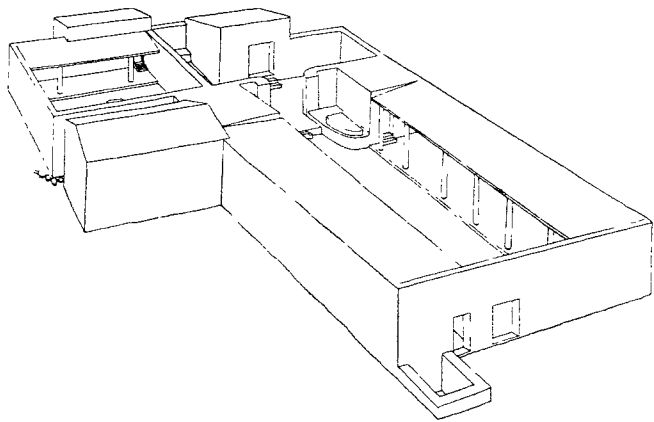

Fig. 274. Soli. Reconstructed sketch of Temples B and C with subsequent alterations (Period 4?).

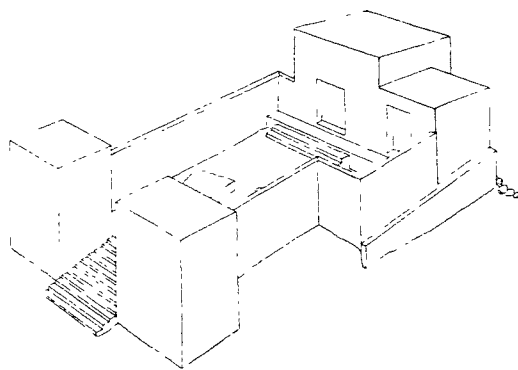

Fig. 275. Soli. Reconstructed sketch of Temple D (Period 2).

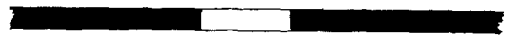
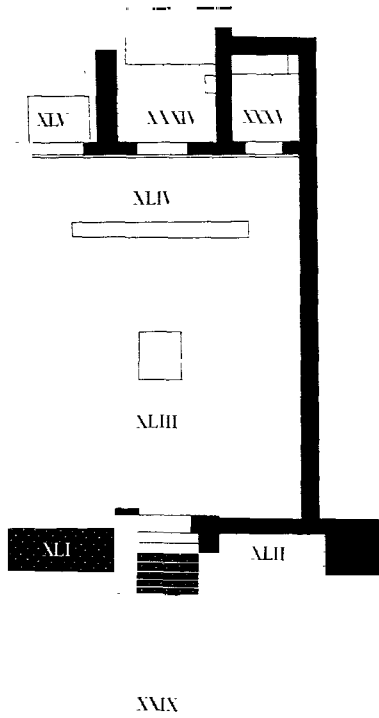

Fig. 276. Soli. Original plan of Temple E (Period 3).

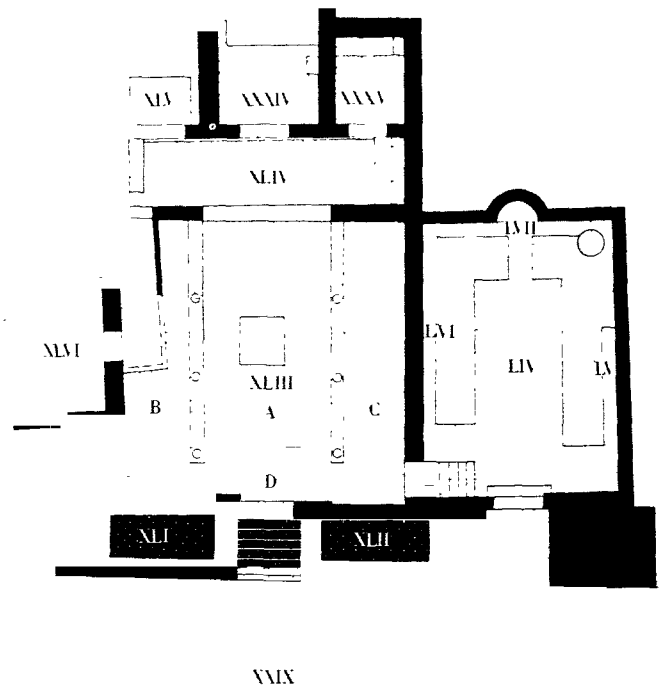

Fig. 277. Soli. Plan of Temples E and F as in Period 4.

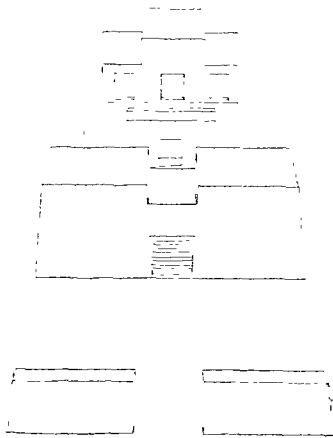

Fig. 278. Soli. Reconstructed sketch of Temple E (Period 3).

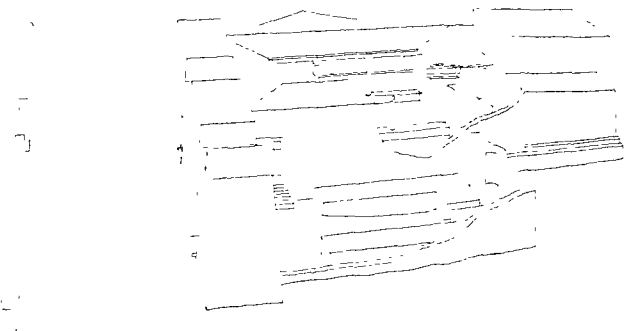

Fig. 279. Soli. Reconstructed sketch of Temples E and F as in Period 4.

the axiality plays a great role in this construction as well as in some others within the excavated area. The new lower courtyard, Room VI, extends up to the boundary or terrace wall of the upper courtyard. Probably the difference of level between the two courtyards was connected, as in Period 1, by means of a short ramp leading up between Walls 11 and 12 A. The shape of the upper court was also changed. Its northern boundary was aligned with the north wall of the lower court. This long, straight wall was connected with the *cella* and with the terrace wall (12 A) by means of walls. Thus the north portion of the upper court was enclosed on three sides. On the opposite side, the old south wall of the courtyard was levelled. A new wall (45) was laid out some 3.60 metres north of the other, and parallel to the sides of the *cella*. In this way there arose a narrow passage between the *cella* and the new wall which may have been closed by means of wooden doors. Possibly the altar in the *cella* (Room V) should be ascribed to this building period.

Temple C. The new construction south of the *cella* consisted of a square courtyard behind which another *cella* (Room XVIII) was placed. The entrance to the courtyard is connected by means of a stair (161) from the lower court of the temple B. This, consequently, is common to both the new constructions, and in Wall 21, close to the entrance to the temple B with the *cella*, Room V, there is also another entrance which must be considered as being for Temple C with the *cella*, Room XVIII. Again we note a certain striving towards the axiality as to the entrances and the altar: the wall (45) which separates the two upper courtyards (VIII—IX and XVI—XVII) was removed to the north just sufficiently to give place for the entrance above Stair 161. The southern entrance through Wall 21 is also fixed as to its situation (it should have been placed in the corner but was removed slightly to the north because of the Cisterns 169 and 170). The rule of axiality caused the queer placing of the entrance to the *cella*, (XVIII) to the north-east corner of the room, and the altar to the north-west corner just in front of the entrance. As far as possible the three entrances and the altar were placed on the same axis in spite of the great difficulties caused by the surrounding architecture and the ground in general. At the rear of the square courtyard (Room XVI) there are two bases for columns, placed symmetrically at a distance of 2.50 metres from the rear wall. The columns, evidently served as supports for a roof above this part of the courtyard, the rest of it being open. Near the middle of the courtyard are some remains of an altar (148). The Water-conduit 167 must be ascribed to this building period as it is bonded to Walls 52 and 22. The way in which it comes through the latter wall at its west end confirms this. The conduit terminates in Cisterns 169 and 170, which also are ascribed to the same epoch of building.

Temple D. The water-conduit is evidently laid out with consideration to the great block of buildings in the southern part of the excavated area. At the narrow passage between Rooms XVI and XXXV, where the conduit turns round the corner of the latter, it is bonded to the exterior of Wall 71 A. This shows, as is confirmed elsewhere, that a building south of the conduit was constructed at about the same period as the Temples B and C, described above. The planning of this building, which can also be identified as a temple, shows many features common with the others. From the east, a stair (163) leads up to an open courtyard

(Rooms XXXI and XXXII). This is somewhat irregular in shape and is laid out in accordance with the natural rock-plateau. At the rear of the court there is a wide stair (164) which leads up to a narrow terrace in front of two *cellae* (Rooms XXXIV and XXXV). In front of the entrance to the courtyard, there are traces of a sort of towers the nature of which cannot be determined as the remains are very scanty. Near the middle of the courtyard some traces of two altars are preserved. They are orientated in east-west direction.

Period 3.

Temple E. The temple D must have been almost totally destroyed and afterwards some buildings were constructed just west of it (cf. below, the Second intermediate period). As two separate building periods can be distinguished in these constructions it seems natural to suppose that some time had elapsed between the destruction of the old temple and its rebuilding partly on the old foundations. The new temple is constructed in accordance with symmetrical principles. The foundations of the old temple *cellae* were re-used and, south-west of Room XXXIV, a third *cella*, Room XLV, was added symmetrically to Room XXXV. This new tripartite construction constitutes the rear of a rectangular courtyard which is of larger size than the court of the first temple. Exactly on the long axis of this building is the entrance to the court, flanked by constructions which most likely should be reconstructed as towers on either side of the entrance. These extend partly beyond the width of the courtyard. Outside these towers there was a second courtyard (Room XXIX) extending in front of the whole temple. This lower courtyard was bounded by a retaining terrace wall (122) parallel to the façade of the temple, and provided with an entrance on the same middle axis. At the rear of the upper courtyard, just in front of the middle *cella* (Room XXXIV) there was a small terrace held by a retaining wall (103). It corresponds to the terrace in front of the two *cellae* of the first temple, Wall 74. In the middle of the rectangular courtyard there was an altar on the axis of the middle *cella*. This is the plan of the new temple as it was built originally. The alterations which can be demonstrated must be ascribed to a subsequent period.

Period 4.

Alterations in Temple E. The additions to the original construction of Temple E have been distinguished above as being of a subsequent character. The terrace in front of the three *cellae*, and the courtyard in front of this were partly roofed in. On either side of the terrace, short benches are built along the side walls of the temple, extending in front of the entrances into the side *cellae*. The corresponding parts of the terrace were enclosed with walls (100 and 104) against the side portions of the courtyard. On the southern side, Wall 100 was provided with a door, the threshold of which is partly preserved, which opens on to a wooden floor supported by Walls 101 and 102. The floor is laid out along the side wall of the courtyard and leads to a doorway through Wall 89 at the side of the courtyard. By

means of the doorway a small chapel outside the wall is entered. This chapel, too, which is provided with an apse opposite the door, is a later addition to the original building. In the middle of the courtyard, on either side of the central altar walls were built which are of such a weak construction that it hardly can be possible that they once extended to the same height as the side walls of the courtyard. They are founded on debris above the rock and are preserved to a low height. The nature of the walls can not be explained otherwise than as a foundation for rows of columns, possibly of wood, which supported a roof along the insides of the courtyard. It is true that none of the bases proper were preserved, but no other explanations of the walls can be found. That this is right is confirmed by similar alterations on either side of the lower courtyard of the temple B (cf. below).

Temple F. Another addition to the Temple E, which should be dated to the same period as the roofing in of the courtyard, constitutes the temple F, constructed against the northern long wall of the courtyard of Temple E. This wall was partly destroyed and rebuilt in connexion with the temple mentioned. This is of quite another type to the previously described constructions which all are built in accordance with similar principles: one — three *cellae* at the rear of a courtyard. The Temple F must have been roofed entirely. It is rectangular in shape and provided with an entrance passage to the east between solidly constructed towers, the southern one being the same as the northern tower of Temple E. The entrance is placed on the long axis of the building. In the rear wall, is a small apse, and on either side of the long axis, the benches. Temple F is connected with Temple E by means of a stair in the southern angle of the room.

Alterations in Temple B. An interesting agreement exists between the subsequent alterations of Temples E and B. Whether the rebuilding should be dated to exactly the same period or not remains uncertain, but they are marked in the same way on the analytical plan in order to avoid too many titles. The sides of the lower courtyard of Temple B are roofed in as in Temple E. Here, however, the foundations for the bases are preserved along two lines parallel to the sides of the court. It may be noted that there is no symmetry as to the position of the bases, *i. e.* the columns of the one side do not correspond to those of the other as columns usually do on either side of the central nave of a church. In Temple B the conditions are probably to be explained as two porticos independent of each other. The southern portico leads up to Stair 161, *i. e.* the entrance into the Temple C, while the northern portico leads to a small square chamber (Room X) which was constructed in the northern corner of the courtyard. The meaning of the long Walls 26—28 in this portico remains uncertain. South-west of the Room X a round altar was erected outside the wall and in connexion with this, the gate between the two courtyards of the temple was altered with the small stair (159) as described above. To this temple, too, some new chapels were added, the largest one being Room XXIII with the entrance through the south wall of the courtyard. The position of this reminds one of the small chapel, Room XLVI of Temple E. To the north of the *cella* of Temple B another room, possible a temple *cella*, was constructed. Probably this belongs to a temple, the rest of which was not found. The passage, Room IX,

which originally might have been closed by a wooden door, was blocked up entirely in a subsequent period. The upper courtyard thus became closed on all sides.

First intermediate period.

In this synthetical description of the temples and their development, the remnants of some other constructions which cannot be brought into direct connexion with the temples have been omitted. On account of their position, they can be divided into two groups which are separated as well on local as on chronological grounds. The earliest group of walls is to be found in the deep area between Temples B and E, partly extending under the floors of Temple F, and Room XXIII. As the floors of this construction (Rooms XXI and XXII) cover the well (171) which belongs to Period 1, the construction must be later than this. On the other hand Wall 57 extends under Walls 71 and 22 which shows that it must be earlier than the Temples B and D. Chronologically this first intermediate period, therefore, must be placed between Period 1 and Period 2.

Second intermediate period.

The second system of walls which was omitted is found in the south-west portion of the area investigated. To this Walls 76—77 and 85—87 belong. It has previously been pointed out that all these walls must be of a later date than the walls of Temple D. This is clearly ascertained by the stratification as well as by the bonds of the walls. On the other hand the walls have been levelled off in order to give place for Temple E. This shows that the second intermediate period should be placed between the destruction of Temple D and the building of Temple E.

Summing up the main features of the various temple plans of the different periods, we see, in the first period, a rather loose connexion between the *cella* and the irregular courtyards in front of it. The lower courtyard is oriented in an east-west direction while the upper courtyard and the *cella* diverge slightly from this axis. In Period 2 (Temples B, C, and D) the shape of the temples is still rather irregular, though the connexion between *cellae* and courts is much closer. A certain tendency to mark the rear of the upper court is noticed. Thus Temple C has a roofed-in portico in front of the *cella* while Temple D has a small ledge with a stair to the court. In the third period, Temple E is constructed with the *cellae* and the court built together to a closed unit. Axiality and symmetry are features clearly expressed in this building. In Period 4, two of the courtyards are more or less roofed in, while several closed chapels are built, among them Temple F. The development from open courts, connected with one or more *cellae*, to the closed, roofed-in building is undeniable as to these temples. This is true also as to the development from a construction with well separated architectural elements to a building of which the various details and portions are, though distinguishable, worked into a close building with a simplified exterior outline.

RECONSTRUCTION OF THE TEMPLES

The reconstruction of the various temples has already been discussed in connexion with the chapters on the architectural analysis and synthesis. A few words may be added here on a couple of questions which may deserve some further explanation.

Temple A.

In the reconstruction of this temple, the remains are too scanty for any safe conclusions. It seems, however, impossible to doubt that the temple *cella* (Room V) was roofed. The courtyards were certainly open, but possibly the gate into the lower courtyard should be reconstructed with a roof. Whether the construction south of the upper courtyard was roofed, too, remains uncertain, but most likely this was the case as the room was rather small and closed in on all sides. (Fig. 270).

Temple B.

The reconstruction of the first building of Temple B also remains uncertain. The absence of any kind of supports in the lower courtyard indicates that the court was open. There are no signs which allow us to reconstruct the upper courtyard otherwise. The *cella* was certainly roofed. This is ascertained on account of the many fragments of roofing-tiles which were found in the *cella*, and in front of its entrance. The original height of the walls of the courtyard should most likely be reconstructed in accordance with boundary walls of modern gardens. The exact height of the *cella* cannot be stated, but it may be reconstructed as an ordinary country house in Cyprus. The roofing of the houses with tiles, however, does not allow a reconstruction with flat roof. The roof must slope at least 10—15° in accordance with modern principles of building in Cyprus. Supposing that the slope was arranged in the same way as in modern houses, it was lower at the back of the building, which is also the most convenient way of avoiding the rain-water coming in at the front of the house. (Fig. 271).

A similar reconstruction may be suggested for Room X. Here, however, the conditions are more complicated as also the sides of the lower courtyard subsequently were roofed in as has been described. Room XXIII must also have been roofed, to judge from the many fragments of roofing-tiles which were found on the floor of this room. Perhaps a gabled roof would be the most natural construction here. (Fig. 274).

Temple C.

The roof of the temple *cella* (Room XVIII) should best be reconstructed as the *cella* of Temple B. The two column bases on the courtyard in front of the *cella* indicate that the rear of the court was provided with a roof, supported by the columns. This portico may be reconstructed in a very simple way, probably as the small veranda in front of modern Cypriote peasant's house. The height of the columns it is, of course, impossible to state. It seems, however, to be natural to suppose that the fragment of a column found at the side of Stair 162 should be connected with the supports for the portico (Figs. 231 and 271).

Temple D.

The reconstruction of this temple may be made in accordance with the previous ones. The temple *cellae* must have been roofed and the courtyard open. There exists no material for other conclusions in this question. As to the entrance into the courtyard, however, and the reconstruction of the remnants in connexion with this it must be admitted that nothing can be stated with certainty, as the walls are preserved in such a bad state. There seems to be traces of flanking constructions on either side of the wide stair, but whether these are of the same nature as the suggested flanking towers in Temple E, or if they should be reconstructed otherwise, remains uncertain. Most likely, however, in consideration to the superimposed entrance of Temple E, there has been some kind of buildings on either side of the stair. How they were roofed is impossible to state, nor can it be cleared if the stair was provided with a superstructure, or if it had only a roof or if it was entirely open. The terrace or ledge at the rear of the courtyard is supposed to have been open as no remains of a roof or supports for the same are preserved. (Fig. 275.)

Temple E.

This temple, as it was constructed originally may have had the three temple *cellae* closed while the courtyard was uncovered. The question here is the reconstruction of the solid buildings on either side of the stair up to the courtyard (Rooms XLI and XLII). How are these to be explained? Evidently, they form a symmetrical façade of the temple against the courtyard, Room XXIX. The foundations are very solid and the outer short walls are strengthened by means of an unusual thickness. In spite of the wall being preserved to some height no floor could be discovered in any of the Rooms XLI and XLII. Nor were any entrances of the rooms to be found. All these circumstances make a reconstruction of this façade in the shape of an Egyptian gate (pylon) probable, as we know them from many Egyptian temples. Certainly the gate of Temple E must have been on a very modest scale in comparison with the Egyptian constructions but the peculiar features and similarities as regards the plan cannot be denied. For a further discussion of this matter reference is given to the chapter on the foreign relations of the architecture. (Fig. 278).

The alterations made in a subsequent period in Temple E, are comparatively easy to reconstruct, as we have all the foundations of the added walls preserved. The eastern gate and the *cellae* remained as before, whereas the small terrace in front of the *cellae* certainly was roofed in. The new walls at the ends of the terrace (Walls 100 and 104) are preserved to a height superior to the terrace itself, which shows that the walls in question really constituted screens between the ends of the terrace and the sides of the courtyard. The roof may be reconstructed as on the portico of Temple C, or sloping towards the court. The southern wall (100) was provided with a door opening out to a narrow passage which also might have been closed against the court by Wall 102. The floor of the passage is situated on a level slightly above the floor of the courtyard. Perhaps Wall 100 should not be reconstructed as a high wall but as some kind of fence, separating the passage from the court. There is no evidence to show which is the right suggestion. The

width of the doorway into the chapel, Room XLVI, cannot be stated with certainty nor can the exact extent of the passage be fixed. The chapel, Room XLVI, must have been roofed. The small size of the room indicates this, but it seems safer not to make any suggestion as to the nature of the roof. It cannot possibly have sloped towards the south-west as the apse would cause some difficulties. Perhaps a gable-roof would be the most natural solution in this case. The steps at the ends of the main terrace may need some explanation. They are too big to be explained as stairs and, besides, to what would such stairs lead? Apparently they are benches or seats on either side of the terrace hidden from the courtyard by the Walls 100 and 104.

Now, we come to the roof of the courtyard. It must be pointed out at once that there are no traces of columns or supports of any kind for a roof, but still, there may be no other interpretation of the conditions, possible. Wall 103 has never been much higher than at present, which is confirmed by the fact that the elevation of the upper surface of the wall is nearly the same all over. Only the ends were partly built over in connexion with the additions to Walls 100 and 104. Thus no objection can be made to the suggestion that the centre of the terrace was open towards the courtyard, while the sides were closed by Walls 100 and 104. Now, Walls 107 and 108 should be explained. They abut just against the ends of the walls mentioned and run parallel to each other, and to the sides of the court towards the entrance wall, and terminate 1.60 m. from it. The wall can be reconstructed either as solid and of the same height as the others, or as a low substructure for a fence or more likely a row of columns or supports for a roof. The weak character of the preserved parts of the walls prevents us from accepting the former suggestion. The walls are not strong enough to bear the heavy masses of stones which such walls should contain, and, besides, there were only a few fallen stones found in the vicinity of the walls. If the side portions really were separated from the centre of the courtyard by means of walls, they must have been of wood. But such a reconstruction is really not reasonable. What should the meaning be to separate two thirds of the courtyard from the open centre around the altar by closed rooms which in any case must have been roofed? The only reasonable explanation of the walls mentioned might be that they were foundations of a stylobate for two rows of columns placed symmetrically on either side of the open central area around the altar. Similar arrangements are frequently used as well in contemporary and earlier architecture, as in modern constructions of Cyprus. The courtyard, therefore, is like a peristyle court with closed sides. In the middle an open portion remains uncovered, just around the altar. The limitation of the open centre towards the south-east is marked by somewhat stronger portions of the Walls 107 and 108; on the latter wall this is very clear. The parts were made stronger in order to receive the weight of the columns in the corners of the central part. These columns had to support the roof just inside Stair 165, too. As the original places of the columns are no longer preserved on the stylobates, we may start from this corner of the central area and divide the walls in three portions each, placing two columns in the intervals. In doing so, it will be seen that the altar, situated practically in the middle of the central

part of the court, will come just opposite the intervals between the middle columns of the walls. This may be a proof that the suggested reconstruction is right. (Fig. 279).

There exists a slight asymmetry as to the width of the aisles. The northern one is not as wide as the southern one. But this finds its natural explanation by the passage into Room XLVI, which should fill almost the whole width of the aisle on this side. The altar, however, was built in a period before the roofing-in of the courtyard, and is therefore not situated exactly on the middle axis between the rows of columns.

Temple F.

The reconstruction of the upper parts of this temple can hardly have been otherwise than with a gable-roof placed on the walls of the building. Walls 140 and 141 may, therefore, be explained as buttresses to Wall 124. How the apse was connected with the roof remains uncertain. Possibly it ended before it reached the roof. The foundation north of the entrance passage is interesting as it shows a striving towards symmetry. This part might be reconstructed in the same way as the flanking constructions in Temple E.

FINDS

OBJECT REGISTER

- 301 Siren of hard limestone; standing on a small irregular base; straight bird's feet, rather carelessly sculptured; feathers marked out at about the knees. Just below hips the human body begins. It is slightly bent backwards and carefully sculptured with navel and breasts; the arms are folded; the hands grasping the long hair coming down on either side of the head. The face is almost round and fat; nose and mouth damaged. Long hair parted in the middle and hanging down on either side. On the back, large wings; the bird's tail almost unsculptured. Height 59.5. Width of wings 32.8. It is said to have been found at the site of Cholades by the villagers who tried to hide it in one of the empty tombs. Thanks to the activity of the police, however, in 1901, it was found there and brought to the Cyprus Museum, where it is exhibited with No. E 146.
- 302 Seated sphinx of hard, grey limestone. Head and upper parts of wings missing. Head made separately from body. Rectangular base. The sphinx is seated in the same attitude as No. 536. The technical difference, however, between the pieces is obvious. Here the legs are clumsy and conventionalized; the body has very few naturalistic marks; no muscles or ribs are indicated and the tail ends simply on the left hind leg. Height 64.0. Found by the land-owner in a wall which later was called No. 90.
- 303 Female head of hard limestone; broken off below neck; left side partly damaged; round face; wide, somewhat smiling mouth; short, crude nose; pointed elliptical eyes with lids; long hair with careless, wavy curls. The drill frequently used between curls, and for forming the mouth. Height 18.0. Found by the land-owner in the field, under conditions which make it necessary to connect the head with Temple E.
304. Lower part of a semi-nude female statue of white marble; broken off through ankles and waist; yellowish patina. The statue rested on its left leg; right leg slightly bent. It is draped in a tunic which hangs down over back and left side, leaving right leg uncovered. The tunic is held by right hand which partly hides the genitalia. Nearly life-size. The statue was found built into a wall of the old church at the village Galini not far from Soli. It was supposed to have come from the site Cholades by the peasants of that village but it could not be ascertained whether this was true or not.*
305. Large ornamental piece of architecture provided with reliefs; hard limestone. These are entirely worn away with the exception of a small figure of Victory, in the

* Only thanks to the benevolence and the personal action of the Bishop Makarios of Kerynia I was allowed to remove the statue from the church-wall for further examination and photographing. But I had to promise to replace it again, in the wall, where it thus still remains, now sheltered, however, by a piece of cloth. As it belongs to the church, the statue cannot be expropriated by the Government.

- upper left corner of the slab. It is upright, facing to the right, and holds a wreath. XXXIV.
306. Bronze coin. *Obverse*: Female head facing right. *Reverse*: Eagle standing on a thunderbolt; closed wings. Inscriptions indecipherable. Possibly dating from late Ptolemaic period. Diam. 2.0. Weight 8.5.
307. Bronze coin. *Obverse*: Inscription within wreath, inscription worn. *Reverse*: Double cornucopia, filleted, with a poppy-head between the horns; border of dots. Diam. 1.43. Weight 2.3.
308. Bronze coin. *Obverse*: Male head facing right; laureate; around, . . AND . . ; below XX. *Reverse*: Laurel wreath; within JE and *. Diam. 1.68. Weight 3.6. XXXIV, below floor.
309. Coarse cooking-pot; rounded base; belly tapering upwards; wide, down-turned, flat rim. Two small handles below rim. Height 20.0. LIV, floor.
310. Oblong base with feet of a seated animal, most likely a sphinx. Upper side, somewhat convex. The paws provided with large claws. Length 48.0. Width 27.5. Thickness 12.0. LIV, below floor.
311. Dove of hard limestone. Head and end of tail missing; surface much worn. The legs are not sculptured but in their place is a small, square base with a hole for fixing the dove from below. The body is horizontal, the long wings being close to the body. Length 41.0. Height 28.0. XXXIV, upper layers.
- 312+313. Two animal heads, the one possibly of a wolf, the other a dog's head (cf. p. 545). Both heads are of the same general character, broken off at the collar. Both have a peaceful expression. One side of the heads is more carefully worked than the other indicating, that the dogs have been placed either at the sides of some object or other figure, or close together. The heads may be explained as belonging to a statue of Cerberus in which case the right, larger head (No. 312) represents the wolf's head and the left one (No. 313) that of a dog, viz. the Alexandrine type of Cerberus. Length No. 312: 17.0; No. 313: 15.0. XXXIV, floor.
314. Large female head in rather soft, white limestone, representing Isis. Broken below neck; the back part of the head is entirely missing; forehead with parts of the cork-screw curls damaged. The head is turned slightly to the left. The face is oval and very realistically sculptured; prominent chin with a small dimple in the centre; aquiline mouth with protruding lips. The eyes are deeply set and sculptured with elliptical lids. The expression of the face is severe and mourning, with sad mouth and deep eyes. The hair is curled in vertical screw curls, hanging around the face, even over the forehead. Around the crown, the hair is gathered in by a ribbon. Over the forehead, there is the base of a crescent, the tips of which are missing. The technique is fine and careful, different from most of the other sculptures. Height 42.5. Total width 24.0. Temples 18.0. XXXIV, Layer 2.
315. Nude, male statue of hard limestone. Left foot, and arm, right leg, and head missing. Breaks through left leg and right upper arm. The leg is slightly bent; body upright. The back is somewhat more carefully worked than the front, which is very rough. Width of shoulders 28.0. XXXIV, floor.
316. Nude, male statue of hard limestone standing on a small, irregular base; right leg from foot to hip, also arms and head missing. The statue was standing on right leg with left leg bent; upright body; arms were sculptured free from body. The statue is carefully sculptured all round. Behind the legs is a projection broken off from the base which served as a supporting pillar for the statue. The head was made separately from the body and fitted on to it by means of a small cavity in the body. Height 103.0. Feet to hips 60.0. Hips to shoulder 32.5. Shoulder 27.0. XXXIV, floor.
317. Female torso of a large statue of hard, grey limestone. Broken through the thighs and obliquely through right shoulder; right arm missing. Upright body; left arm slightly bent along the side. The head was made separately from the body and set into a depression on it. Vertically folded chiton and himation hanging over left shoulder and wound across the abdomen outside left arm, with deep folds. The folds are sculptured as deep, distinct grooves, the ridges between which have sharp edges. Flat, unsculptured back. Height 89. XXXIV, Layer 2.
318. Large head of hard limestone, representing Serapis. Broken through neck. The face is that of an elderly man with puffy cheeks, strong, straight nose, and deep, tragical eyes with lids and heavy eyebrows. The chin is covered by a very thick beard conventionalized with symmetrical, deep borings. The entire head is surrounded by a mass of curly hair, this, too, conventionalized with deep borings. On the back, which is rather roughly sculptured, there is a circular incised line indicating a small cap or more likely a ribbon in the hair. Height 38.0. Total width 31.0. Temples 15.7. XXXIV, floor.
319. Female statue in hard limestone standing on a small irregular base with right foot slightly advanced; right arm nearly straight and hanging downwards along the side, the forearm free from body; left arm bent, the hand holding left breast from below. Head is facing forwards; oval face; small, aquiline mouth; short, thick nose; large eyes with elliptical lids and convex eyeballs. The dress is very complicated. It should be regarded as a sort of cult-dress. The legs are hidden by a thick tunic, or petticoat which hangs down with stiff folds, leaving the sandalled feet uncovered. The petticoat is decorated with four pairs of squares, filled with figures in relief and surrounded by ornamental borders of a peculiar kind. The technique in which they are executed suggests that they imitate embroidery. With the exception of the lowest pair, the figures of each are alike and facing the ver-

- tical, central border. 1st pair: — peacocks; 2nd pair: representations of the soul (Ba); 3rd pair: the cow-goddess Hathor lying; 4th pair: left side, embalming scene with a mummy, a man holding the bands and a priest dressed as the god Anubis; right side, winged Isis and some other figure which seems not to be interpretable. All these reliefs are more or less made *en creux*. Apparently the whole arrangement with borders and fields for pictures is inspired by paintings on Egyptian mummy-coffins which, however, are misinterpreted by the Cypriote artist. The vertical borders are decorated with a meander (central panel) and plaitwork (side borders). The horizontal borders are on either side alike: uppermost border, chain of lozenges with a dot in the middle; 2nd border, conventionalized vine; 3rd border, chain of upright ovals encircled by and connected with incised lines
- Over the hips the statue wears a cuirass ornamented with winged griffins in low relief, the tails of which end in an ornamental vine, the griffins facing each other. Around the waist there is a belt equipped with alternating square and rhombic stones. The breast of the statue is covered by an *aegis* or coat of mail composed of small, scale-like plates with rounded ends, hanging downwards. The coat covers the upper arms, but is without sleeves. Below neck, a necklace consisting of two strings with rows of pendants. The head-dress is horizontally fluted from brow to occiput and extends under the coat of mail at the back; from the temples, two ribbons hang down to the upper part of the breast. Back rounded but unsculptured. The whole statue is resculptured from the torso of another larger statue, some remains of which can be seen on the back of the base, where breast-folds of a tunic are distinguishable. Total height 100.0 Feet to hips 48.0. Hips to crown 47.0. Shoulders 26.0. XXXIV, floor.
- 320 Head of Isis in hard grey limestone, made separately from the body. The head may belong to the body, No 317. Comparatively long, stiff neck; oval face with somewhat pointed chin; realistically sculptured mouth; straight brow- and nose-line, slightly sloping; the eyes distinctly sculptured with elliptical lids; right eye damaged; left eyeball is flat, filed off. The long, wavy hair is parted in the middle and falls down the sides of the head, hiding the ears. On the top of the crown, there is a crescent, the right point of which is broken. Rounded, roughly sculptured back. Height 40.0. Total width 19.4. Temples 11.4. Forehead to back 17.7. XXXIV, Layer 2
321. Fragment of left foot of a more than life-size statue of hard limestone. The sandals are provided with a tongue which hangs over the ankle. Length 21.0. XXXIV, floor.
322. Fragments of a marble inscription. See Appendix III, XXXIV, floor.
323. Fragments of a marble inscription. See Appendix III, XXXIV, floor.
324. Cornucopia of hard limestone; moulded tip and edge. Ribbons are wound around the cornucopia which is filled with various fruits, among which grapes and pomegranates are distinguished. Two spikes hang over the edge. Length 50.0. XXXIV, floor.
325. Fragment of a bronze bracelet worn by Isis priestesses. Only the end of the bracelet is preserved; it is shaped as a raised uraeus with crown. Length 10.2. XXXIV, floor.
- 326 a) About 120 pieces of various bronze objects without determinable shape. They are intentionally broken into very small portions. Some of the pieces simply moulded. Length 1.0.—5.0.
b) About 60 pieces of bronze with parallel sides and varying width. Length 1.0—5.0.
c) Various pieces of melted lead. Length 0.5—4.0. XXXIV, floor.
327. Terracotta lamp: moulded; ovoid shape; vertical handle; on edge small spirals in relief; on discus rosette-ornament; central hole. Nozzle damaged. Length 8.9. XXXIV, floor.
- 328 Female head of hard, coarse-grained, yellow limestone, broken below neck; partly worn; tip of nose missing. Long, powerful neck with two horizontal wrinkles; oval face, vigorous, prominent chin and nose; deep corners of the mouth; deeply set eyes sculptured with distinct contours; protruding eye-balls and well marked lids; the upper one arched, the lower almost straight. The eyes seem to look upwards. Gently curved forehead with slightly prominent middle. The wavy hair is parted in the centre, visible only just above the forehead. Over the crown hangs a veil or more likely a himation, the borders of which are visible at the sides of the head. The back is rounded but carelessly worked. Height 32.4. Total width 21.2. Temples 13.8. Chin to back of head 25.0. Wall 69, upper part.
329. Statue of hard limestone, representing Canopus. Circular, moulded base, bobbin-shaped, jar-like body without legs or arms. The body is crowned by a human head with face, fat cheeks, and wide nose, the tip of which is broken off. The eyes were inlaid with filling (now wanting). The head wears a small, curly goatee beard with long, wig-like hair falling on both sides over the breast. On the abdomen are decorations in relief: The lower part of the reliefs seem never to have been finished. In the centre of the stomach there is an uraeus, facing left, with coiled tail. On either side of the uraeus, birds are facing each other. Across the breast there is a necklace consisting of pendants with inlaid filling (now missing). Another necklace with only one pendant of the same kind as the lower ones, encircles the neck. Suspended from the head and passing round the back, the statue wears a *mandorla*-shaped tunic, with three folds visible from in front. The head is crowned by an Egyptian, palmette-shaped

- head-dress inlaid exactly like the pendants. The back is unsculptured. The torus above the base may be explained as the piece of cloth, which the natives place on the skull when carrying a water-jar on the head. Height 77.0. Base diam. 36.0. XXXV, on Altar 155.
330. Bronze coin; part of it missing. *Obverse*: Bust of Licinius, r.; laureate; around, inscription *IMPLICI-NIVS*... *Reverse*: Jupiter standing, l.; leaning on spear in left hand; in right hand, thunderbolt; left of figure, R; right of figure, S; around, inscription illegible. Diam. 1.7. Weight 2.3. VIII.
331. Bronze coin; illegible. Diam. 1.8. Weight 2.3. Stray find.
332. Bronze coin. *Obverse*: Heraclius standing facing; wears crown with cross and long robes in r.; long cross potent; in l., globus with cross potent. *Reverse*: I B Globus with cross potent in ex. *ΑΙΕΞ*. Diam. 1.6. Weight 4.6. Stray find.
333. Bronze coin. *Obverse*: Bust of Trajan r.; radiate, wearing paludamentum; around, inscription rather worn *ΑΥΤΟ ΚΡΑΙΟΝ*... *ΑΝΩΑΠΙΟΤ*... *Reverse*: Temple of Aphrodite at Paphos; above the two cross-beams, tied to tops of central columns, is a garland the ends of which hang down outside; on either side slender column; in front semicircular court; the cone has a double flat top and a star on either side; below, inscription *ΚΟΙΝΟΝΚΥΠΡΙΩΝ*. Diam. 2.73. Weight 12.9. V.
334. Male head of hard limestone, probably representing one of the Dioscuroi; broken off at neck; nose damaged. Oval face with straight mouth; wide brow, almond-shaped eyes with lids and convex eyeballs. Half-long, slightly conventionalized hair with deep borings in the centre of the curls. On the back the hair is indicated as irregular grooves. The head wears a rounded conical cap, the *πίλος* of Dioscuroi. Height 21.0. Temples 8.2. XXXIV, floor.
335. Snake wound in a complicated and irregular way around a cornucopia; broken in many pieces, which fit together with the exception of two pieces of the snake's body and the upper part of the cornucopia. The group rests on a circular base; the whole is made from one piece of stone. The head of the snake is put in a horizontal position. Probably it was feeding on the fruits in the cornucopia. The skin of the snake is carefully sculptured, with different kinds of scales on back and belly. Between the long incised eyes there is a loop-shaped design. Height 45.0. XXXIV, floor.
336. Flat, male statue in soft, grey limestone. Lower part from hips, and head missing. Upright, flat body. Right arm along the side; left forearm bent holding a bird close to the breast. Vertically folded chiton with short sleeves and gathered in by a belt around the waist. On right, hangs a himation with the edge from right shoulder obliquely across the body, leaving the chiton visible on right side. Flat back. Height 19.0. Shoulders 12.2. Breast to back 4.5. XXXII, floor.
337. Base of a statue with naked feet; hard limestone. Right leg preserved up to above the knee. Careful technique. Height 32.5. XLIV, floor.
338. Limestone head of similar character as No. 334, broken off through neck; mouth, nose, and right cheek damaged. On the crown, there is a fracture after some high, apparently triangular head-dress or cap, which is wanting now. Back is carefully worked. Height 18.1. Temples 9.9. XXXIV, floor.
339. Male statue of hard, grey limestone. Lower part from thighs and head missing. Upright body; right arm along the side, the hand holding a round object; left forearm raised, close to the side. Chiton with short sleeves. Around the body a himation is wound the end of which hangs over left shoulder. Plain back. Height 30.0. In Wall 99.
340. Torso of a nude, male statue of hard, grey limestone. Surface rather weathered. Broken through right thigh and left knee; head, right arm, and left forearm missing. Right leg seems to have been slightly advanced. The body is upright and carefully sculptured even on the back. Right arm was sculptured free from the body. Left arm akimbo holding a himation, which hangs over left shoulder along the side, on the back of the statue. Height 38.0. Shoulders 18.5. In Wall 89.
341. Fragment of the cornucopia of No. 335. XLIV, floor.
342. Female head in hard limestone, of similar type as No. 319, but without grooves on the head-dress. The technique is much coarser; surface roughly sculptured and never smoothed. Nose missing. Height 20.0. Temples 11.0. XLIII c.
343. Fragment of the breast of a male statue of hard limestone. Length 21.0. XXX.
344. Five bronze leaves, probably belonging to a wreath. The leaves are carelessly cut out of a thin bronze sheet. One of them has plain edges, the others have pointed lobes. On two of the leaves are traces of gold indicating that the leaves probably were gilded originally. Length 6.0—7.2. XXXII.
345. Handle of a bronze vase, shaped as a dolphin. The tail-fin ends in a lotus-flower, whose middle petal is pierced by a rivet. The body of the fish has circular section and widens towards the head. Two large, striated fins on the sides, behind the eyes; upturned nose. Length 8.1. Outside XXXI; cf. Section XV, level 120.0.
346. Bronze coin. *Obverse*: Bust of Constantine, r.; laureate; draped; with cuirass; around, inscription (first part missing) *IMP CONSTANTINVS PFAVG*. *Reverse*: The Sun, radiate; half-nude, face to the right; left arm raised holding the globe; around, inscription: (first part missing) *SOLI INVICTO COMITI*. Diam. 2.05. Height 2.7. XLIII A.
347. Bronze coin. *Obverse*: Head of Licinius r.; laureate, around *IMPC VALLICIN LICINIVS PFAVG*. *Reverse*: Jupiter standing, l.; left arm raised resting on a sceptre or spear; in right hand, Victory present-

- ing him with a wreath; on ground, left, eagle with wreath. Around (on either side, inscription IOVICONSERVATORI. To the right of Jupiter, B. Below, S M K. Diam. 2.0. Weight 2.8. XLIV, floor.
348. Bronze coin; illegible. Diam. 1.3. Weight 0.8. XXXIV, below floor.
349. Terracotta lamp; flat base; curved sides; bulging upper side; inturned rim; narrow hole at centre; thick nozzle; coarse, red clay. Length 8.4. XXXII, below floor.
350. Coarse cooking-pot; rather squat shape; moulded rim; vertical handles below rim. Diam. 20.5. XXV, deposit.
351. Moulded terracotta lamp; flat base; no handle; volutes on nozzle; moulded eagle on discus, ex-central hole. Length 9.2. XXV.
352. Moulded terracotta lamp, as No. 378. Length 8.8. XXV.
353. Moulded terracotta lamp, as No. 351. Length 9.1. XXV.
354. Moulded terracotta lamp; flat base; no handle; diminutive nozzle; impressed cymatium on edge; moulded circles on discus. Length 7.0. XXV.
355. Moulded terracotta lamp, as No. 385. Length 9.3. XXV.
356. Moulded terracotta lamp; pierced, vertical handle; volutes on nozzle; cymatium on edge; radiating lines and circles on discus; central hole. Length 9.1. XXV.
357. Moulded terracotta lamp; no handle; plain flat base; volutes on nozzle; plain rim; central hole. Length 8.7. XXV.
358. Moulded terracotta lamp, as No. 378. Length 9.5. XXV.
359. Moulded terracotta lamp; no handle; volutes on nozzle; moulded *chitaroidos* on discus; excentric hole. Length 8.8. XXV.
360. Moulded terracotta lamp; impressed circles round base; no handle; diminutive nozzle; plain discus. Length 7.2. XXV.
361. Moulded terracotta lamp; flat base; volutes on nozzle; moulded star on discus; central hole; nozzle damaged. Length 6.8. XXV.
362. Moulded terracotta lamp; slightly raised base; vertical handle (missing); volutes on nozzle; plain edge; on discus two cornucopiae. Length 9.0. XXV.
363. Moulded terracotta lamp, as No. 360. Length 7.5. XXV.
364. Moulded terracotta lamp, as No. 360. Length 7.0. XXV.
365. Moulded terracotta lamp, as No. 383. Length 8.6. XXV.
366. Moulded terracotta lamp; somewhat elevated base; pierced, vertical handle; volutes on nozzle; impressed leaf-ornaments on edge; deep, plain discus. Length 9.2. XXV.
367. Moulded terracotta lamp, as No. 378. Damaged. XXV.
368. Moulded terracotta lamp, as No. 378. Length 8.7. XXV.
369. Moulded terracotta lamp, as No. 360, but with impressed circles on discus. Length 7.5. XXV.
370. Moulded terracotta lamp, as No. 351, but with a Gannymede on the back of an eagle, on the discus. Length 8.8. XXV.
371. Moulded terracotta lamp, as No. 351, but with *gladiator* instead of the eagle. Length 8.5. XXV.
372. Moulded terracotta lamp, as No. 354, but with rosette on discus. Length 8.0. XXV.
373. Moulded terracotta lamp, as No. 351, but with a bird on a bough instead of the eagle. Length 8.8. XXV.
374. Moulded terracotta lamp, as No. 354. Length 7.5. XXV.
375. Moulded terracotta lamp; flat base; no handle; volutes on nozzle; moulded rosette on discus; ex-central hole. Length 8.6. XXV.
376. Moulded terracotta lamp, as No. 385. Length 9.4. XXV.
377. Moulded terracotta lamp, as No. 356, but plain. Length 9.5. XXV.
378. Moulded terracotta lamp, as No. 385, but with plain discus. Length 8.0. XXV.
379. Moulded terracotta lamp; slightly raised base; thick, prolonged nozzle; pierced, vertical handle; small, plain discus; floral reliefs on edge. Length 9.7. XXV.
380. Moulded terracotta lamp, as No. 354, but with wreath of oak leaves on edge and rosette on discus. Length 7.0. XXV.
381. Moulded terracotta lamp, as No. 357. Length 8.4. XXV.
382. Moulded terracotta lamp, as No. 378. Handle damaged. Length 7.8. XXV.
383. Moulded terracotta lamp; flat base; vertical, pierced handle; diminutive nozzle; wavy knobs on either side; slightly moulded discus. Length 8.6. XXV.
384. Moulded terracotta lamp, as No. 360, but with impressed circles on discus. Length 7.5. XXV.
385. Moulded terracotta lamp, as No. 356, but with diminutive nozzle and no volutes. Nozzle damaged. Length 9.8. XXV.
386. Moulded terracotta lamp, as No. 383. Length 8.6. XXV.
387. Moulded terracotta lamp, as No. 357. Length 8.1. XXV.
388. Moulded terracotta lamp, as No. 385. Length 9.3. XXV.
389. Moulded terracotta lamp, as No. 378. Length 8.5. XXV.
390. Moulded terracotta lamp, as No. 383. Length 8.5. XXV.
391. Moulded terracotta lamp; somewhat moulded base-ring; pierced, vertical handle; faint volutes on nozzle; moulded edge of discus; central hole. Length 9.5. XXV.

392. Moulded terracotta lamp, as No. 384. Length 7.5. XXV.
393. Moulded terracotta lamp, as No. 378. Length 9.1. XXV.
394. Moulded terracotta lamp, as No. 356, but with diminutive nozzle and no volutes. Handle damaged. Length 9.4. XXV.
395. Moulded terracotta lamp, as No. 356. Length 9.9. XXV.
396. Moulded terracotta lamp, as No. 378. Length 9.6. XXV.
397. Small bottle of glass; flattened base; tapering body; long neck; rim missing. Height 8.2. XXV.
398. Moulded terracotta lamp, as No. 378. Length 8.8. XXV.
399. Moulded terracotta lamp, as No. 356, but plain. Length 9.6. XXV.
400. Moulded terracotta lamp, as No. 375, but with central hole. Length 8.5. XXV.
401. Moulded terracotta lamp, as No. 359. Length 8.8. XXV.
402. Small, female terracotta head; broken off below neck; right part of chin and nose somewhat damaged. Oval face of common type; deep eyes with sculpturally marked eyelids. Conical head-dress below which the curly hair is visible. Height 4.0. XLI, on the rock.
403. Female terracotta statuette; hollow and made in a mould; head and right hand missing. The statuette rests on right leg with left leg slightly bent. Right arm raised, probably holding a jar on the head of the statuette. Long, vertically folded chiton reaching the ground; himation wound across body and gathered in by left arm. Traces of red paint on himation. Rounded back with irregular back-hole. Height 13.5. XLI, surface layer.
404. Terracotta lamp; flat, slightly raised base; curved sides; out-turned rim, pinched to a nozzle. Length 8.4. XXX, on the rock.
405. The *kalathos* of a Serapis-statue in yellow marble. The piece is broken off just at the base; cylindrical sides; torus-like edge around the flattened top. Side decorated with two rows of alternating squares and rosettes in low relief rather carelessly worked especially on one side. Height 14.5. Upper diam. 16.0. XLV, Altar 156.
406. Two pieces of a column-shaped lamp of white marble; circular base; fluted stem; moulded top with a piscina-shaped bowl and wide outlet. The lamp has been sawn in two pieces from top to base. The two halves were probably placed against the wall above Altar 156 in Room XLV. Lower part of one half missing. Height of lamp 54.0.
407. Square slab of hard limestone with the mourning Eros sculptured in high relief. There is no base on which he stands (feet partly missing). Legs almost straight; body upright; left arm is raised to the back of the head grasping the quiver, which is visible, more hinted than sculptured, just above left side of head. In the same way a diminutive bow is hinted as an emblem at the side of right thigh. Right arm is placed obliquely across the body to the left side, and holding a torch turned straight down and parallel with left leg. The torch widens towards the flame which is to be seen just in the corner of the slab. The large, round head is slightly turned forwards and surrounded by curly, reddish-painted hair with deep borings used as decoration. Eros is nude but wears bracelets around ankles and upper arms. Slab. 10.0 x 53.0. Eros' height 50.5. Hip to shoulder 15.0. Feet to hip 24.0. XLV, Altar 156.
408. Fragment of the breast of a male statue of hard limestone. Height 15.0. XLV, Altar 156.
409. Oblong marble slab with inscription in Greek letters. The short sides are carefully levelled. See Appendix III. Length 42.0. Width 15.0. Thickness 11.5. XXVII, among fallen stones from Wall 124.
- 410 + 411. Two fragments of a male statue in hard, grey limestone. The upper fragment (No. 410) is broken just below the hips; right hand and head missing. The other fragment (No. 411) consists of the base with the legs up to about the knees. The base is irregular with horizontal upper side. Left leg is slightly bent; body upright. Arms slightly bent along the sides; left hand holds a bird close to the side. Short-sleeved chiton and himation hanging over left shoulder and wound around the body. The naked feet and legs are not sculptured free from the background. Unsculptured back. Height No. 410: 30.0; No. 411: 18.5. In Wall 95.
412. Base with the feet of a large statue of hard limestone. The lower part of the legs were sculptured as a relief. Length 48.0. Width 27.0. Height 20.0. In Wall 95.
413. Female head, possibly of Aphrodite, in hard, grey limestone, broken through neck. Face is much worn and piece of chin missing. Only parts of the eyes can clearly be distinguished as concerns the face. They are realistically sculptured and, evidently, deeply set which is noticeable at the base of the nose. The long hair is parted in the middle and gathered on the nape of the neck. Lower parts of ears visible below the hair. The head wears a ribbon over the hair. Height 20.0. Total width 16.5. Temples 11.0. In Wall 90.
414. Female head of white, coarse-grained marble, representing Agrippina the elder. Nose damaged. The head was made separately from the body and fixed to it by means of an iron peg set into a hole visible from below. The neck is long and sculptured with three indistinct, horizontal wrinkles. The face has a rather triangular shape with a prominent chin and a very broad forehead. The aquiline, distinguished mouth has thin lips, but is not deeply bored. The eyes are distinctly designed with a well marked brow-line and lids enclosing the eye-balls elliptically. The hair

- is parted in the middle and combed to the sides. Over the temples, there are four rows of small spiral curls sculptured separately from each other. At the centre of each curl, there is a small dimple made with the drill. At the sides of the neck and emanating from behind the ears are wavy curls. The back of the head is unsculptured. On the top of the crown there is a rounded fracture of some kind of a head-dress which now is missing. Height 33.0. Total width 24.0. Temples 13.7. Forehead to back 18.0. XVII.
415. Small, female head of white, coarse-grained marble made separately from the body with a hole for a fixing peg in the neck. Nose is damaged. Head is turned a little to the right. Long, narrow, concave neck with two horizontal wrinkles. Face is oval with a small mouth, elliptical eyes, rather deeply set, sculptured with sharply marked lids; curved forehead with slightly prominent parts above the eyes. The long hair is parted in the middle, combed backwards and tied on the nape of the neck. The hair is carelessly worked, designed by means of straight parallel grooves. Parts of the ears are visible below the hair. The head once was set into a depression on the statue. Height 10.7. Total width 5.2. Temples 3.8. Forehead to back 6.0. V, floor.
- 416+463.
Statuette of nude Aphrodite in fine-grained, white marble, broken in four pieces with fractures through right thigh, waist, and neck. Lower parts of legs, arms, and part of neck and left shoulder missing. Aphrodite stands on her right leg with left leg raised. The body is bent over left knee and turned to the left. She looks at some object (now missing), which she probably held with her hands over her left knee. The head (No. 416) does not exactly fit to the body, but there is no doubt that it belongs to it. It was broken already in ancient times and mended by means of an iron peg which was found sitting in the head (on the body there is a corresponding hole). The face is very carefully sculptured with slightly prominent chin, almost straight front, and nose-line. The eyes are treated in a very soft way with lids, but without eye-balls. The gently curved forehead has its centre slightly prominent. The hair is sculptured in a peculiar way. It is parted in the middle and combed backwards and tied on the nape of the neck. The waves of the hair are marked by various incisions, which gives a good impression of realistically sculptured waves. Below the hair, parts of the pierced ears are visible. The oxidation of the iron pin for fixing the head has caused some damage to the head which thus has a crack through the neck and left cheek. — On the side of the left thigh, there is an oval fracture, the remains of some object attached to the statue. Height 26.0. V, floor.
417. Fragment of right foot of yellow marble belonging to a statue. To the same statue also the pieces Nos. 437 and 464 belong. The fragment consists of the forepart of the foot, which is naked. The toes are realistically sculptured. Part of a garment is visible just above the toes. The foot stands on a small irregular base just large enough for it. On the side where the foot was attached to the statue, there is no real fracture but the surface is cut even and there is a hole for an iron peg. Length 8.3. Width 6.2. V, floor.
418. Statue of hard limestone representing Cybele. Head and right forearm, head of right lion missing. The goddess stands in an unusual upright position on a small base between two seated lions, resting on her left leg with right leg slightly bent. The female figure is recognized below the dress. Left arm is bent and kept close to the body holding a small tympanon in front of the breast. Head was made separately to be set into a depression on the statue. Cybele wears a vertically folded chiton reaching the ground. It is held together by a ribbon tied just below the breast. From left shoulder hangs a long, folded himation obliquely over the body. The end of the himation is held by left arm whence vertical folds hang down. The back of the statue is unsculptured but rounded. Height 37.5. Shoulders 13.0. V, floor.
419. Upright, female statue of soft, grey limestone. Right foot and forearm and head missing. The statue is standing on a small irregular base with right leg slightly bent. Left arm is along the side, the hand holding a flower; the forearm is sculptured free from the body. Around left wrist, there is a plain bracelet. Two others are visible on right upper arm. The statue wears a short-sleeved, long, vertically folded tunic, reaching the ground just leaving parts of the feet uncovered. The tunic gathered in below the breast by a ribbon has two horizontal folds over the abdomen and hips. The fold over the abdomen is double and arched in a peculiar way suggesting a line of fringes. Unsculptured, flattened back. Height 51.0. Shoulders 16.0. Abdomen to back 9.0. V, floor.
420. Bronze coin. *Obverse*: Bust of Maximinus, r.; laureate; draped; around, inscription MAXIMINVS PIVS AVG GERM. *Reverse*: Winged Victory, standing with face to the left; holding a wreath; in front of her, seated prisoner; around, inscription VICTORIA GERMANICA (partly worn). To the left of figure, S; to the right, C. Diam. 3.1. Weight 21.7. V, floor.
421. Bronze coin. *Obverse*: Head of Zeus, r.; encircling line. *Reverse*: Eagle with lifted wings, standing on the thunderbolt, l.; around, inscription, illegible; in front of eagle, above, A (much worn), and below N. Diam. 2.7. Weight 14.8. V, below floor.
422. Bronze coin. *Obverse*: Bust of Gordianus, r.; laureate; draped; around, inscription IMP GORDIANVS PIVS FEL AVG. *Reverse*: the Sun standing, radiate; half-nude; face to the left; right arm raised; left hand holding globe; around, inscription AETEP NITATI AVG. To the left of figure, S; to the right C. Diam. 2.9. Weight 18.6. V, floor.

423. Bronze coin. *Obverse*: Bust of Mamaea, r.; draped; diadem; around, inscription IVLIA MAMAEA AVGVSTA. *Reverse*: Venus standing; face to the left; holding a helmet and a sceptre; around, inscription VENVS VICTRIX (partly worn away); left of figure, S; to the right, C. Diam. 3.1. Weight 24.8. V, floor.
424. Bronze coin. *Obverse*: Bust of Licinius, l.; draped; helmet and cuirass; holding a spear on right shoulder; around, inscription DNVALLICIN LICINIVS NOBC. *Reverse*: Jupiter half-nude standing; left arm leaning on spear; right hand holding a Victory on a globe presenting Jupiter a wreath; to the right of the figure seated prisoner; to the left, eagle holding a wreath in the beak; around, inscription IOVICON S ERVA-TORI; below SMANTJ; above prisoner, III. Diam. 20.0. Weight 2.3. V, floor.
425. Female head of white, fine-grained marble, broken below the neck. Tip of nose damaged. The head is slightly turned left. Oval face; well marked chin with a small dimple in the centre; the mouth is marked by wavy line, not very deep. The nose is rather broad at the upper part, rather long and was probably just a little concave. The forehead is gently curved with a slightly prominent middle. In relation to the nose-ridge the eyes are deeply set and sculptured with faintly marked lids, the upper one of which is arched; the lower one, however, a little heightened but not exactly straight. The hair is arranged in five realistically sculptured "melon rolls". Only the lower parts of the ears visible below the hair. The back of the head is obliquely cut off and roughly levelled. It may be that the back of the head was added in some other material e. g. gypsum or stucco, which now has disappeared. The technique used for this head is marked by an extreme softness. All planes are gently melted the one into the other and there are no sharp lines in the treatment of the mouth and the eyes. Height 14.0. Total width 8.0. Temples 5.5. Chin to crown 8.5. V, floor.
426. Small, female terracotta head made in a mould. Rounded, pleasant face; hair combed with "melon rolls" partly covered by a hat or cap on the back of head with up-turned edge. Triangular leaves or rosettes behind ears. Red paint preserved on hat and hair. Height 4.2. XLII.
427. Statue in hard, grey limestone representing a mourning Isis, kneeling on a piece of a column. Right hand and one side of the column damaged. The body is upright with a strictly frontal position; left hand pressed to the thigh; right arm bent to the body. The neck is short and thick; oval face showing an expression of profound grief; large open eyes with elliptical lids, distinctly worked. From the base of the nose run marked wrinkles. The long hair is parted in the middle, combed backwards and gathered in a coil on the nape of the neck. Isis wears a small convex cap, which covers only the back of the head. The parting of the hair in the middle is engraved even on the cap. In the course of his work the artist probably changed his mind and sculptured the cap. Isis wears a long, folded tunic reaching to the feet. A shawl is suspended from both shoulders with long fringes hanging down and radiating over the abdomen. The shawl is gathered up by a twisted band below the small breasts. The style is primitive and the artists' laboured attempt to impart a mournful expression to the attitude of Isis is rather comical. Height 46.3. Knees to back 15.0. XVII.
428. Base of white marble for two statuettes. Oblong shape. One edge on the back is levelled. On the front, inscription in Greek letters. See Pl. XXIV, 15. Length 41.0. Width 22.4. Thickness 9.0. VIII, floor.
429. Body of a very much corroded statue of alabaster. Apparently the attitude was similar to No. 446. Height 40.0. V, floor.
430. Glass bottle with flattened base; body tapering upwards; tubular neck; stilted rim. Height 6.0. V, below Altar 147.
431. Glass bottle with rounded base; convex body tapering upwards; contracted neck-line; tubular neck; stilted rim. Height 5.3. V, below Altar 147.
432. Glass bottle with round base; gentle outline; tubular neck; wide rim (fragm. missing). Height 6.2. V, below Altar 147.
433. Glass bottle with concave base; body tapering upwards; somewhat concave sides; tubular neck; splaying rim. Height 7.4. V, below Altar 147.
434. Glass bottle with somewhat concave base; contracted neck-line; cylindrical neck, upper part missing. Height 6.7. V, below Altar 147.
435. Glass bottle; concave base; body tapering upwards; splaying rim. Height 10.0. V, below Altar 147.
436. Glass bottle with flattened base; gently curved sides; stilted rim. Height 10.7. V, below Altar 147.
437. Right hand holding a plate. Yellow marble. The piece is broken 3 cm. above the hand, where it has been mended by means of an iron peg, already in ancient time. The fracture is, however, not levelled. The hand is carefully sculptured and holds the plate with four fingers below. No nails are designed. The plate of which a small piece is missing has a small rim and a knob in the centre. Length 17.0. Diam. of plate 12.3. V, floor.
438. Female head of white marble probably belonging to a statue of Aphrodite. The head is broken obliquely through neck just below the chin. Only a small piece on the right side missing; the rest in perfect state of preservation. The head is elaborately sculptured though the absence of the neck imparts to the head a disfiguring fullness, noticeable especially on the slightly prominent chin, which has a small dimple in the centre. The face is oval with rather full cheeks. The mouth is deeply bored as are the nostrils; the upper lip short. The nose is straight and delicately worked, the base of it being comparatively broad. The eyes are not very deeply set but very distinctly

- sculptured with somewhat sharp lines marking the lids, which limit the eye-balls almost elliptically. The forehead is gently curved with a slightly prominent middle. The ears are partly visible below the hair. They are realistically sculptured and the drill is used for the deeper parts. The wavy hair is parted in the middle and combed backwards. Around the crown there was a ribbon added probably in some other material; crown is almost unsculptured. The back of the head, flat and unworked, is provided with a hole for an iron rod either for fixing the statue to a wall or something similar or for fixing the back part, which then must have been worked in some other material (cf. No. 425). The eyes were painted in white with dark iris, the paint now being very faint. There are also traces of red paint on the hair. Height 22.7. Total width 16.9. Temples 12.3. Forehead to back 14.9. Neck-fracture 10.5 x 10.9. V, floor.
439. Upright, female statue of hard, grey limestone. Right forearm and head, made separately to be set into a depression on the statue, missing. The statue rests on left leg with right leg bent slightly backwards. Upright body in a very quiet position. Left arm bent close to the body, gathering up the himation. On the upper arms are spiral bracelets with ends shaped like snakes' heads. The statue wears a long, vertically folded tunic without sleeves, fastened over the shoulders by pins. Below the diminutive breasts, the tunic is gathered up by a thin ribbon. An obliquely folded himation is wound around the lower part of the body and is borne up by the left arm, from which the ends hang down in vertical folds to the knees. The back is round, but unsculptured. Height 80.0. V, floor.
440. Silver denar. *Obverse*: Head of Severus, r.; laureate; around, inscription LSEPT SEVAVG IMPXI PERTINAX. *Reverse*: Fortuna standing, face to the left; holding a cornucopia and a sieve; around, inscription AEQVIT (end of inscription illegible). Diam. 1.9. Weight 3.0. V, floor.
441. Bronze coin. *Obverse*: Male head, r.; distinguishable. *Reverse*: Entirely worn away. Diam. 1.9. Weight 2.3. V, floor.
442. Bronze coin. *Obverse*: Bust of Trajan r.; radiate, wearing paludamentum. Inscription worn away. *Reverse*: Entirely worn away. Diam. 2.7. Weight 11.1. V, floor.
443. Female head of soft, grey limestone, broken below neck. Elaborate work but worn; part of nose broken and missing. Face is oval with well marked chin; aquiline mouth; straight nose with broad base. Eyes are deeply set and carefully elaborated with elliptical lids. Gently curved forehead with slightly prominent middle. The hair is parted in the middle and arranged as a kind of torus over the forehead. On the back, the long hair falls down with distinctly worked waves at the sides. Ears partly visible. The head wears a crown or diadem, the back part of which is covered by a veil, falling down over the back-hair. The crown is decorated with palmettes. Height 14.0. Total width 8.2. Temples 5.9. V, floor.
444. Bronze coin. *Obverse*: Bust of Trajan r.; bare-headed wearing paludamentum; inscription worn away. *Reverse*: Zeus Salaminus standing to front, facing, wearing chiton and himation. Other details and inscription worn away. Diam. 3.4. Weight 24.3. Stray find.
445. Bronze coin. *Obverse*: Bust of Caracalla r.; laureate, around, inscription ΜΑΝΤΩΝΕΙΝΟC ΑΥΤΟΒΥCΤΟC. *Reverse*: Temple of Aphrodite at Paphos; central portion consisting of two tall columns each ending in two points, joined by two cross-beams with four metope-like openings between them; side-wings roofed, and each containing column supporting lamps in front; semicircular court; paved; enclosed by lattice-work fence with open gates; above central portion, star in crescent; on roof of each wing, a dove; in court, one oblong object (terrace below the middle *cella*), two circular (altars), and a dove facing to the right. The cone has a pointed top; around (above) inscription ΚΟΙΝΟΝ [ΚΥ]ΠΠΙΩΝ. Diam. 3.23. Weight 20.5. V, floor.
446. Statue of very soft, grey limestone, representing Cybele sitting on a throne supported by two lions. The state of preservation was so bad that, after a few days in the open air, the statue dissolved into a powder in spite of all attempts to preserve it. Head of Cybele, part of tympanon and the forelegs of the lion on right side missing. Cybele is seated on a throne holding a large tympanon in her left hand; the right arm rests on the head of the lion. Over the breast, three plaits hang on each side. She wears a long chiton just leaving the feet uncovered, and a long deeply folded himation. On each side of the throne the lions stand symmetrically. They are realistically sculptured, but, unfortunately, badly damaged. Height 50.0. Shoulders 21.0. Base width 24.5. V, floor.
447. Torso in white marble, representing Aphrodite, broken through hips, upper arms, and neck. The body is slightly bent to the right. A piece of the long hair is seen on the back between the shoulders. The neck fracture is pierced for a peg fixing the head. The fracture is oblique and not levelled. Height 13.3. Shoulders 9.5. Waist 6.3. XIII.
448. Bearded head, or mask of hard, coarse limestone; broken off through neck. Only the face is sculptured, with four vertical strips of beard hanging straight down from the lower lip. This beard and the half opened mouth are surrounded by a long, slightly curled moustache. Short, wide nose with vertical brow- and nose-line; eyes roughly sculptured. On the head is a plain cap, or helmet below which the short front-hair is marked by a horizontal line. Sides and back, flat and unsculptured. Height 21.4. XXXV, on Altar 155.
449. Bronze coin. *Obverse*: Bust of Licinius, r.; radiate; draped; cuirass; around, inscription IMPCVAL LICIN

- LICINIVS PFAVG. *Reverse*: Jupiter standing, face to left; half-nude; left arm leaning on a spear; right hand holding a Victory on a globe; to the right of the figure a seated prisoner; to the left, eagle holding a crown with its beak; around, inscription IOVI CONSERVATORI; right of figure III^M; below SMKA. Diam. 2.0. Weight 2.9. XXIX, floor.
450. Iron rod bent into a loop, with a straight pin. Length 22.5. Diam. 5.8. V, floor.
451. Bronze coin. *Obverse*: Bust of Maximianus (?) r.; radiate; around, inscription IMPCM AVR VALMAXIMIANVS PFAVG. *Reverse*: Jupiter and Hercules standing face to face; the former holding globe and sceptre; the latter Victory, club and lion's skin. Around, IOVETHERCVCONSER AVGG. Diam. 2.23. Weight 3.3. IX.
452. Idol (?) of yellow marble, broken at one end; very queer sculpture, found in two pieces, fitting well to each other. A bobbin-shaped body can be distinguished with a concave frontside and a back. The frontside has fifteen small projections resembling warts or nipples arranged in three rows. The top, where the head would be expected is simply conically ended, the very tip being broken. The back is flattened and provided with three arched grooves. At the sides, diminutive bent arms are indicated. On the back, corresponding beginnings of legs are marked by a groove. On the frontside of this broken end, the same legs are distinguished but beginning much lower. Between these legs the fracture of another body can be seen though this is missing. The monstrous figure may be interpreted as a being at the moment of a childbirth and had probably some sacrificial purpose. Length 25.5. Width 10.5. XIII and XVII.
453. Egg-shaped, green stone, heavy and hard. The whole surface is notched with a hammer. On one side the letters I B F are notched in. See Appendix III. Length 24.0. XIII.
454. Bronze coin. *Obverse*: Laureate bust, r.; draped; with cuirass; around, inscription FLIVL CONSTANTIVS NOBC. *Reverse*: two soldiers with helmets leaning on spears and shields; face to face; between them, two military signs; around, inscription; illegible. Diam. 1.9. Weight 2.3. XIII.
455. Bronze coin. *Obverse*: Female bust r.; much worn. *Reverse*: Entirely worn away. Diam. 2.57. Weight 11.1. XIII.
456. Bronze coin. *Obverse*: Bust of Julia Domna r.; behind, crescent; around, inscription IOVI IO MNAC EB. *Reverse*: Temple of Aphrodite at Paphos, as on No. 445; around (on either side) KOINON KVHPION. Diam. 3.38. Weight 21.6. V.
457. Bearded head, possibly representing Zeus, of yellow, coarse-grained marble, broken through neck. Surface worn. The back of the head is missing and was possibly added in some other material as has been suggested as regards No. 425. The front part of the beard is damaged and the nose worn away, but the head seems once to have been a good work. The full beard is rather short and has a rounded outline. The eyes are deeply set and realistically worked. The forehead is gently curved and has a slightly prominent middle above the broad base of the nose. The hair is in disorder. Height 13.0. Total width 9.0. Temples 6.2. Forehead to back 7.3. XII, below floor.
458. Fragment of the breast of a small marble statuette, probably female; broken through body with oblique break. Himation hanging down on back from both shoulders with heavy folds over the breast. Height 8.5. Width of shoulders 5.6. XII.
459. Terracotta lamp, moulded, as No. 378. Length 8.2. XVII, floor.
460. Base of alabaster for a small statuette; rectangular shape. Length 7.3. Width 5.7. XII, below floor.
461. Two fragments of a statuette, probably female, in yellow marble.
a) Lower part with the feet standing on small base. The legs are hidden by a long himation which falls in artistic folds. Close to the feet, on left side, the base of a square pillar. Flat back. Height 11.6. Total width 14.5. Toes to back 10.5.
b) The upper part of the pillar mentioned with the left hand of the statue resting on it. XII, below floor.
462. Male head of hard limestone; surface badly damaged especially the face. Hair is parted in the middle. High head-dress, widening upwards and simply moulded. The break on the back of the head indicates that it probably was a part of some architectural decoration. Height 8.3. XII.
463. Fragments of a marble statuette. Cf. No. 416. VIII.
464. Left hand of the same statue as No. 437 and probably also No. 417. The piece, which is broken just above the hand holds a torch directed downwards. The hand is carefully sculptured in the same style as No. 437. The torch consists of a bundle of sticks held together by strings in three separate places. The flames of the torch are burning downwards, twisted around a conical base. — Four pieces mended in the usual way by means of iron pins. The fractures between the fragments have not been levelled. The torch was painted with vertical red lines. The flames, too, were painted red. Length 50.0. VIII.
465. Oblong marble slab with bluish veins; thin; edges bevelled backwards. The front has an inscription in Greek characters arranged in four lines. See Appendix III. Length 43.5. Width 18.1. Thickness 3.2. VIII.
466. Torso of a nude statuette, probably representing Aphrodite. Legs from the knees, right arm, left forearm, and head missing. Right breast slightly damaged. In the fracture from the head, which not has been levelled, there is an iron peg for fixing the head. Aphrodite stands with her right leg slightly advanced; the upper part of the body is gently bent to the left. Apparently the right arm was raised above the head.

- Left arm was partly sculptured free from body and slightly bent, directed downwards. On the back, there is a band running obliquely from right shoulder to the waist on the left side. Certainly this band was held by the hands of Aphrodite. On the outside of left thigh, there is a fracture of some object or, more likely a support for the statue sculptured from the same piece of marble. The surface is not polished, but mat and between the fractures on the thigh and that of right arm the surface has been roughly smoothed only. The drill has been used in the deeper parts e. g. for marking the line between the legs, in the arm-pit, and for boring the navel. When the statuette was found red paint was noted on the genitalia, but this has now almost entirely vanished. Height 23.3. Shoulders 8.2. Waist 6.5. Hips 8.4. Abdomen to back 4.7 Knee to hip 11.5. Hip to shoulders 11.2. VIII.
467. Moulded terracotta lamp; ovoid shape; flat base; vertical handle-knob without hole; impressed circles and dots around edge; on discus, Christian cross with small circles at the ends and in the middle; two holes in discus. Length 8.6. Stray find.
468. Oblong base for a statuette; white marble; on the upper side a cavity for the statuette to be fitted in. Length 18.5. Width 14.0. Height 4. XII.
469. Bearded head of a satyr in hard limestone, curiously resembling Socrates. Broken off below neck. The face is round; with thick lips; short, wide nose; puffy cheeks, large eyes with arched lids; the eyebrows are prominent and arched. The forehead with horizontal wrinkles is very short. The head wears a long, curly, slightly conventionalized beard with moustaches. On the skull there is no hair, with the exception of patches around the large, crescent-shaped animal ears. The back of the head is spherical. Height 28.0. Total width 17.3. Forehead to back 18.8. XVII.
470. Spherical stone; similar to No. 453. The present shape is obtained by means of notchings with a hammer. On one side an "N" is hammered in. Diam. c. 20.0. VIII.
471. a) Bronze button; circular with moulded edge and trace of a nail in centre. Diam. 3.7.
b) Circular plaque of lead with a central knob. Diam. 4.8.
Both objects might have belonged to a lamp-stand; b) as weight in the foot. V, floor.
472. Small, female head of terracotta; moulded face; back of head missing; broken off below neck. Dull details of face. Hair parted in the middle and combed backwards. Diadem over the crown. Height 4.8. V
473. Pierced, conical bead of dark, red amber. Diam. 2.2. Wall 6.
474. Head of small, female terracotta statuette, holding a jug on the head with right hand. Broken below neck and through right elbow. Moulded face with dull details; somewhat curly, long hair, parted in the middle. Height 4.8. XXXVI.
475. Arrow-head with flat tang; lancet-shaped blade without mid-rib; point somewhat curved. Length 12.0. XI floor.
476. Small, female terracotta head; broken off through neck; moulded face with dull details. Long hair parted in the middle and tied on the back of the head. Over crown a wreath or diadem. Height 3.7. XI.
477. Small, female terracotta head with moulded face, made separately from body. Head slightly turned to the right; oval face with regular design of a very soft character. Long hair parted in the middle and combed backwards. On either side remains of a wreath. Height 5.5. XI, below floor.
478. Fragments of a seated, female terracotta statuette made in a mould. The head wears a veil leaving the front-hair uncovered. XI, below floor.
479. Bronze coin. *Obverse*: Veiled bust of Faustina I, r.; around, on either side inscription DIVA AVGVSTA FAVSTINA. *Reverse*: Cybele, lowered, seated r. on throne between two lions, holding drum in left hand on left knee, right arm on throne; around, inscription MATRI DE VM SALVTARI SC. Diam. 3.58. Weight 26.4. V, floor.
480. Bronze coin. *Obverse*: Bust of Constantin, r.; diadem; cuirass and himation; around, inscription CONSTANTINVS MAXAVG. *Reverse*: Two soldiers with helmets leaning against spears and shields; face to face; between them, two military signs; around, inscription, illegible; below CONS*. Diam. 1.9. Weight 2.4. XVIII, floor.
481. Bronze coin. *Obverse* and *reverse* illegible. Diam. 14.7. Weight 1.5. XXII, below floor.
482. Bronze coin: *Obverse*: Bust of Constantin, r.; laureate; draped; with cuirass; around, inscription IMP CONSTANTINVS PFAVG. *Reverse*: Jupiter Sol standing with face to the left; radiate; half-nude; holding globe in left hand; around, inscription SOLIINV I CTOCOMITI. Left of figure S; right of figure F. Below, four illegible letters. Diam. 2.1. Weight 2.5. VIII, floor.
483. Bronze coin. *Obverse*: Bust of Valentinian II, r.; helmeted; cuirass; draped; around, inscription D N VALENTINIANVS PFAVG. *Reverse*: Emperor standing on a vessel; right of him, Victory at helm; around, inscription GLORIA ROMANORVM. Below SMNE. Left of emperor, wreath. Diam. 2.3. Weight 6.6. VIII, floor.
484. Bronze coin. *Obverse*: Bust of Licinius, l.; with helmet and cuirass; holding a spear on right shoulder; around, inscription DN VALLICIN LICINIVS NOBC. *Reverse*: Jupiter standing with face to the left, holding a Victory on a globe and a spear, crowned by an eagle. At his feet, left, eagle with wreath in the beak; right, seated prisoner; around inscription IOVICON ERVATORI; above prisoner $\overline{\text{I}}$; below Jupiter SMNB. Diam. 1.9. Weight 3.1. VIII.
485. Bronze coin. *Obverse*: Bearded head, r.; possibly that of Ammon. *Reverse*: illegible. Diam. 1.4. Weight 2.0. XI, below floor.

486. Bronze coin. *Obverse*: Head of Ammon, r.; surrounding circle. *Reverse*: Eagle standing on the thunderbolt; closed wings; left of eagle flower, ☉; around, inscription *ITΘ*, the rest illegible. Diam. 1.3. Weight 2.1. XI, below floor.
487. Bronze coin. *Obverse*: Head of Arsinoe III, r.; lower part preserved; encircling, dotted line. *Reverse*: Double cornucopia with various fruits; encircling, dotted line; around, inscription *ITΘ.IEM.I* (rest illegible). Diam. 1.0. Weight 1.6. XI, below floor.
488. Bronze coin. *Obverse*: Head of Ammon, r.; inside dotted circle. *Reverse*: Two eagles with closed wings facing to left. In front of the eagles, the sign $\frac{\Lambda}{\Sigma}$; around, inscription, illegible on left side; on right side, *ΒΑΣΙΛΕΩΣ*. Diam. 2.3. Weight 5.9. XI, on floor.
489. Bronze coin. *Obverse*: Helmeted head of Constantinople, l.; around (left and right) *VRBS ROMA*. *Reverse*: Romulus and Remus sucking the wolf. Above, two stars; below, inscription *CONS* (last letter illegible). Diam. 1.8. Weight 1.6. VI, floor.
490. Bronze coin. *Obverse*: Bust of Aurelianus, r.; radiate, cuirassed; around, inscription *IMP CAVRELIANVS AVG*. *Reverse*: Woman standing, r.; presenting wreath to emperor, standing, holding sceptre or spear; around, inscription *RESTITVT OP BIS*
 $\frac{S}{XXI}$ Diam. 2.2. Weight 3.8. Stray find.
491. Bronze coin. *Obverse*: Bust of Constantin, r.; laureate; around, inscription *IMP CONSTANTINVS PFAVG*. *Reverse*: Jupiter Sol standing, l.; radiate, half-nude; globe in left hand; around, inscription, *SOLIIN VICTOCOMITI*. Left of figure, R; right of figure, S; below, four letters, illegible. Diam. 1.9. Weight 3.0. Stray find.
492. Finger-ring of bronze with oval bezel; the stone missing. Diam. 1.7. XVI, floor.
493. Fragments of a thin plaque of dark, blue marble, with an inscription in Greek characters. See Appendix III. VII—VIII.
494. Moulded terracotta lamp; base moulded with concentric circles; at the centre a sign III is impressed; on the base-ring, four small circles; vertical handle with three incised lines and pierced by three holes; small, plain nozzle; small circles alternating with double-spirals on rim; on the discus, large lion in relief; face to the left, raised tail; behind it, a tree with branches; the lion is vigorously moulded. Length 21.0. Diam. 14.8. VIII.
495. Female terracotta statuette; made in a mould; head missing; solid clay. Isolinear feet; upright body; right hand holding the pendant of a necklace; left arm holds the folds of the himation, which hangs over left shoulder. Plain, curved back. Height 11.1. Width of shoulders 4.8. IX.
496. Moulded terracotta lamp; flat base; no handle; volutes on nozzle; moulded rosette on discus; central hole. The whole covered with thin, red slip. Length 9.0. Stray find.
497. Female statuette of yellowish, coarse-grained marble. Head missing. The statuette stands on a comparatively large base with right leg bent across the left, on which she stands, leaning against a square pillar with moulded edge. The right leg is visible under the dress. Right arm straight downwards, resting on the pillar; left arm akimbo with the hand resting easily on the hip in an elegant position. The long chiton, close to the slender body, imparts to the statuette a charming rhythm. It covers the feet entirely and is gathered together below the breast by a ribbon. On the back, a shawl hangs from right shoulder to the left upper arm whence it falls down to about the knees. The lower part of the back is almost unsculptured. Height 35.2. Feet to shoulder 29.0. Shoulders 9.0. Base sq. 14.5 \times 18.2. VI, floor.
498. Seated, female terracotta statuette; made in a mould. Dull shape and details. Long, plain tunic and shawl over both shoulders; conical head-dress. Grey, gritty clay. Height 12.0. VI, floor.
499. Male statue of hard, grey limestone. Feet, forearms, and head missing. Surface weathered. Right leg slightly bent; upright body; left arm bent. Short-sleeved chiton and himation over left shoulder and wound around body and legs. Legs are not sculptured free from the background. Flat back. Height 54.0. Shoulders 20.5. VI, floor.
500. Male head of hard limestone; very much worn; no details distinguishable. The head showed good work. Height 13.0. VI, floor.
501. Male head of hard limestone; broken through neck. Round face; straight mouth; large eyes with eyelids. Height 11.8. VI, floor.
502. Female head of hard, grey limestone; broken through neck; chin damaged; surface corroded. Similar to No. 518. Height 21.5. Width 14.5. Temples 10.4. Forehead to back 18.5. VI, floor.
503. Male head of hard limestone; much corroded; broken through chin. The face looks like a portrait; short, wide nose and worried eyes. High forehead and no hair. Height 20.0. Width 13.4. Forehead to back 16.2. VI, floor.
504. Small, male terracotta head. Height 2.9. XI, on the rock.
505. Small, female terracotta head. Height 3.8. XI, on the rock.
506. Small, female terracotta head. Height 4.8. XI, on the rock.
507. Torso of nude, male statue of hard, grey limestone. Lower part from knees and upper part with the breast and the arms missing. Left leg was slightly advanced. On the back and left side a himation is hanging with vertical folds. A large piece of the abdomen with the

- male limb has been hewn away from the sculpture, possibly intentionally. Height 32.0 LIV, among slip-stones
- 508 Torso of a female statue in hard, grey limestone, lower part from hips, arms, and head missing. The piece shows that the statue was represented in a great motion; body turned to the left; both arms were uplifted. The statue wears a vertically folded chiton close to the body and gathered in by a ribbon tied just below the breast. A part of a himation with a carefully worked mass of folds around the hips. Roughly sculptured back. The statue may have made a part of a group. Height 22.7. Breast to back 8.6. LIV, among fallen stones.
509. Head of a lion in hard limestone; broken through neck; tips of ears missing; surface worn. The mouth is half open with four teeth visible. Whiskers sculptured as incised lines; the eyes are comparatively small and deeply set. On the sides the muscles are naturalistically marked. The head may belong to a statue similar to Nos. 312, 313 (cf. above). Height 14.0. Width 10.0 LIV.
- 510 Lion's head of white marble probably used as an outlet for water. The technique is rough with carelessly sculptured eyes and nose. The back is flat. The whole head is pierced by a large circular hole from back, coming out through the mouth. On the upper side there is another hole which possibly served the purpose for fixing the head. Nose to back 12.0. Width 17.0. XXIII, floor.
- 511 Large, female head, of a statue probably representing Aphrodite. Coarse-grained, white marble with yellowish patina; broken through neck; face badly damaged. Neck is stiff and provided with three horizontal wrinkles. Rounded, oval face with full cheeks. The eyes are deeply set, the stress being laid on the lids, which are large and softly sculptured. The middle of the forehead is prominent and the base of the nose is broad. The long, wavy hair is parted in the middle, combed backwards and tied on the nape of the neck. The hair is gathered in by a ribbon around the skull. Below the hair parts of the ears visible. The hair is very softly sculptured. No deep borings are to be seen, all the planes are gently softened without any distinct contours. Height 27.0. Total width 19.8. Temples 12.8. Forehead to nape of neck above tie 18.4. XXIII, just below floor.
- 512 Square plaque of grey, hard limestone. On one side there is an inscription in Greek characters on three lines. This is partly damaged by two incised, concentric circles. Evidently the inscribed slab has been re-used for another purpose, possibly as a base for a column. Appendix III. Length 30.0. Width 28.0 V, floor.
- 513 *Omphalos*, conical slightly convex sides. The uppermost top is broken. As pieces of gypsum mortar was found on the sides it seems to have been used as building stone. Height 18.5. Diam. 18.0. Stray find.
514. Moulded terracotta lamp, as No. 378. Length 7.9. XXVI, surface layer.
- 515 Moulded terracotta lamp, as No. 378, but with plain edge. Length 8.8. XXVI, surface layer.
516. Moulded terracotta lamp, as No. 351, but with two dolphins face to face instead of the eagle. Length 8.4. XXIII, floor.
517. Female head of hard, grey limestone, broken below neck, part much worn. Head turned slightly to the right. Oval face with rounded full cheeks; mouth distinctly marked and aquiline, short, broad nose with concave front- and nose-line. The eyes are distinctly sculptured with arched upper lids and almost straight lower lids. The hair is parted in the middle and arranged with five flat melon rolls on each side which cover the ears. On the nape of the neck is a small flat cap, vertically placed on the hair. The cap seems to be a woollen one. Two ribbons are hanging down from its centre. Height 20.0. Total width 11.5. Temples 9.5. Forehead to back of head 14.0. In Wall 20.
518. Female head of hard limestone, probably representing Aphrodite; broken through the neck. Head slightly turned to the left. Surface rather worn. Oval face with rounded chin, small mouth with deeply sculptured corners. The base of the neck is broad. The eyes are deeply set, looking upwards. The eyelids are very softly treated with somewhat arched upper lids and heightened lower lids. The gently curved forehead has a prominent middle. The long, wavy hair is parted in the middle, combed backwards and tied at the nape of the neck. The hair is gathered in round the crown by a ribbon. All over the head is sculptured with a very soft technique similar to that of No. 425. Height 21.5. Total width 15.8. Temples 10.7. Among slip-stones from Wall 20.
519. Female head of hard limestone similar to No. 518, but with a wreath in the hair. The face is badly damaged. Height 20.5. Total width 14.8. Temples 10.8. In Wall 20.
520. Male head of hard, grey limestone, representing Alexander the Great. Broken below the neck. The head is slightly turned to the left. Short and powerful neck; face carefully sculptured with a strong, prominent chin. The aquiline mouth is deeply bored. The eyes are very distinctly cut with elliptical eyelids and marked eyebrows. The gently curved forehead has a prominent middle. Straight front and front- and nose-line. The long realistic, wavy hair grows from the forehead like a palmette and falls down in great disorder on each side of the head, covering the ears. On the back of the head, the long hair falls in wavy curls. The drill is often used for sculpturing the hair, especially in the deep parts at the sides of the face. Height 22.5. Total width 16.0. Temples 10.0. Forehead to back 18.0. In Wall 20.
521. Female head of hard, grey limestone, broken through the neck. Nose broken; surface worn. The face is oval with rounded chin and cheeks; small, aquiline

- mouth with deep corners. The nose is short and broad, with bored nostrils. The eyes are very distinctly sculptured with arched upper lids and almost straight lower lids. Gently curved forehead with thick brows. The hair seems to be parted in the middle and arranged with melon rolls near the partition. On the nape of the neck, the long hair is gathered in from below and wound into a loose, hanging tie. Height 19.0. Total width 12.0. Temples 9.5. Among stones fallen from Wall 20.
522. Female head of hard, grey limestone, broken through neck. Nose and forehead damaged. Oval face with full chin and cheeks, sloping line below chin; thin, aquiline mouth with depressed corners; small, thin nose with nostrils and gently curved base. The eyes look half closed with elliptical, distinctly cut lids and heavy brows. Gently curved forehead. The hair and head-dress similar to that on No. 517. Height 16.5. Total width 10.8. Temples 8.8. Forehead to back 11.7. Wall 20.
523. Plain White bowl; rounded base; out-turned, moulded rim. Red clay. Diam. 12.3. II, below floor.
524. Plain White bowl with flat base; straight sides, widening upwards; wide, flat rim. Diam. 11.5. XXVII.
525. Moulded terracotta lamp; flat base; straight sides, widening upwards; pierced, vertical edge; nozzle on rim; cymatium on edge; on discus, radiating lines encircled by a wreath of leaves. Length 11.7. XXVIII.
526. Moulded terracotta lamp, as No. 525. Length 11.6. XXVIII.
527. Moulded terracotta lamp, as No. 525. Length 11.5. XXVIII.
528. Moulded terracotta lamp; shape as No. 525; impressed leaves on edge; plain discus. Length 10.5. XXVIII.
529. Moulded terracotta lamp, as No. 528. Parts missing. XXVIII.
- 529 a. Moulded terracotta lamp, as No. 525, but with plain discus. Length 12.8. XXVIII.
530. Male head of hard, grey limestone broken below neck. Nose and mouth scratched. Short, thick neck; round face with full cheeks; small, straight mouth; short nose; eyes are summarily worked with comparatively sharp lines in the elliptical lids. The large, protruding ears seem to have been placed too high. Short, curly hair. Height 11.5. Total width 8.0. Temples 6.2. In Wall 20.
531. Female head of hard, grey limestone, broken below the chin. Nose broken. Long, oval face with carefully worked mouth, nose with broad base; elliptical, deeply set eyes with distinctly sculptured lids. Gently curved brows and forehead. The long hair is combed backwards, indistinctly parted in the middle and tied on the nape of the neck. On top of the crown, is a hole filled with lead apparently for fixing a head-dress. Height 14.0. Total width 12.5. Temples 8.5. Mouth to back of head 16.0. In Wall 144.
532. Female head of white, fine-grained marble made separately from the body to be set into a depression on it. Nose and part of forehead badly damaged, put together of four pieces. The neck is comparatively long with a faintly marked, horizontal wrinkle. Oval face with full chin and small mouth. Eyes and mouth sculptured in the same soft technique as on No. 425. The hair is parted in the middle and combed backwards, and falls down in waves. The hair is tied up by a ribbon around the crown. Below the neck, the upper part of breast visible. Back of the head unsculptured. Traces of red paint on the lips. Height 21.5. Total width 9.5. Temples 6.8. Partly below Stair 161.
533. Eagle of hard, grey limestone. Lower part of legs and head missing. The bird stands with its left foot slightly advanced; the body is in an upright position. The wings are folded close to the body. The feathers are sculptured in a naturalistic way. Length 49.0. LIV, below floor.
534. Male statue of hard, grey limestone. Head missing. Large, irregular base with slightly bent upper side. The statue rests on left leg with right leg slightly bent backwards. The body is upright. Right arm close to the body; left forearm raised, the hand holding the end of the himation hanging from left shoulder. Folded chiton with short sleeves. Across the abdomen and thighs a himation is wound, the end of which hangs over left shoulder. Legs and feet bare, not sculptured free from the background. The technique is rude, the folds being stiff and sharp-ridged. Plain back. Height 42.0. LIV, below floor.
535. Male statue sitting in the conventional "temple-boy" attitude. Right forearm and head missing. Right foot, left knee, and part of the bird damaged. The boy wears shoes and a short tunic with short sleeves and a necklace ending in a knot with a tassel. The body is very plastic with rounded outlines. Height 28.0. LIV, below floor.
536. Body of a sitting sphinx in hard, grey limestone. Base with tibiae on hind legs, forelegs, upper parts of wings, and head missing. The body is very naturalistically sculptured; the tail is curled under the body and projects on the inside of left hind leg; two rows of feathers visible at the bases of the wings. Well marked, female breasts. Length 60.0. LIV, below floor.
537. Moulded, female terracotta head broken off obliquely through the neck. Oval face with small, somewhat smiling mouth. Veil over crown extending down as himation; fracture on the crown of some high head-dress. Height 5.1. Offering pit of Altar 145.
538. Moulded, female terracotta head; broken off below neck. Tanagra-type. Hair parted in the middle and combed backwards. Above crown a diadem with impressed punctures. Height 4.7. Pit of Altar 145.
539. Female terracotta head of Tanagra-type; broken off below neck. The head was somewhat turned to the left. Hair parted in the middle and combed back-

- wards. Around crown, a ribbon tied to a rosette above forehead. Traces of red paint on rosette on hair. Height 5.0. Pit of Altar 145.
540. Female terracotta head of Tanagra-type, broken off below neck. Rounded face with full cheeks; hair parted in the middle; diadem-like head-dress from which a veil hangs down over back of head and shoulders. Height 5.2. Pit of Altar 145.
541. Female head of Tanagra-type; broken off through neck. Long hair parted in the middle. High moulded head-dress from which a veil hangs down over shoulders. Height 4.8. Pit of Altar 145.
542. Female terracotta head, as No. 474. Height 6.0. Pit of Altar 145.
543. Bronze coin. *Obverse*: Head of Ammon, r., in dotted circle. *Reverse*: One eagle with closed wings; standing on thunderbolt; in front of the eagle, \mathcal{J} with a star above; around, inscription illegible. Diam. 2.4. Weight 7.0. LIV, below floor.
544. Bearded terracotta head; lower part Cf. No. 570.
545. Terracotta lamp with somewhat raised base; slightly curved sides; outturned rim pinched into a nozzle. Rim damaged. Length 8.0. XXX, on the rock.
546. Terracotta lamp, as No. 545. Length 8.5. XXX, on the rock.
547. Male head of hard, grey limestone, broken below the neck, which is short and slightly concave. The face is oval with full chin and cheeks; thick lips; slightly concave brow- and nose-line. The eyes are sharply outlined and obliquely placed; arched upper lids and almost straight lower lids. The forehead is well marked and makes an almost right angle with the upper side of the crown. The ears are large and clumsy. The hair is short with the tips of the curls cut along an incised line. Height 14.0. Temples 8.0. XXX.
548. Bronze coin, similar to No. 487. Diam. 1.3. Weight 1.9. XXXVI, below floor.
549. Bronze coin. *Obverse*: Head of Soter, r.; wearing diadem and *agis*. *Reverse*: eagle standing with opened wings on the thunderbolt, l.; around, inscription, partly illegible $\text{HTO.IEM HIOY BAST.IEΩΣ}$; to the left of eagle two signs, above ΛΥ and below ϙ . Diam. 1.9. Weight 7.6. XXXVI, below floor.
550. Flat loom-weight, oval in shape; pierced by a hole. Length 7.5. XXIV, below floor.
551. Moulded terracotta lamp; flattened base; vertical handle pierced by two holes. On discus, radiating relief lines surrounded by a wreath; volutes on nozzle; mottled varnish outside and inside. Length 14.1. XXVI, level 115.0.
552. Moulded terracotta lamp; flat base, circular rim probably without handle; triangular nozzle. Length 7.5. XXVI, level 115.0.
553. Plain White bottle; flat base; pear-shaped body; neck missing. Height 6.6. XXVI, level 115.0.
554. Moulded terracotta lamp; flat base, high, almost straight side widening upwards. No handle; on discus a peacock in relief facing to the right. Volutes on nozzle. Parts of nozzle and discus missing. Length 7.4. II, cavity below floor.
555. Terracotta lamp; flat base, somewhat curved sides; out-turned rim pinched to a nozzle, part of rim missing. Length 7.0. II, below floor.
556. Terracotta lamp, as No. 552. Back part missing. Length 6.8. XXVI, level 115.0.
557. Terracotta lamp, as No. 555. One side damaged. Length 7.4. II, below floor.
558. Flat, circular loom-weight of terracotta, pierced near the edge. Diam. 4.6. II, below floor.
559. Flat, circular loom-weight of terracotta, pierced in the centre. Diam. 5.5. II, below floor.
560. Loom-weight, as No. 559. Diam. 5.3. II, below floor.
561. Loom-weight of terracotta, as No. 558. Diam. 7.6. II, below floor.
562. Loom-weight of terracotta, as 558, but thicker; very coarse clay. Diam. 6.9. II, below floor.
563. Loom-weight of terracotta in shape of a truncated pyramid; pierced near the top. Height 6.4. II, below floor.
564. Loom-weight of terracotta, as No. 563. Height 6.9. II, below floor.
565. Loom-weight of terracotta, as No. 563. Height 5.3. II, below floor.
566. Loom-weight of terracotta, as No. 558. Diam. 6.4. II, below floor.
567. Loom-weight of terracotta, as No. 559. Diam. 7.5. II, below floor.
568. Loom-weight of terracotta, as No. 559. Diam. 7.1. II, below floor.
569. Wheel-made terracotta lamp; slightly raised base; biconical body; narrow, central filling hole with somewhat moulded edge; long nozzle. On one side, pierced knob on body. Black, dull glaze. Length 8.1. II, below floor.
- 570-544. Terracotta head, bearded, representing Serapis; broken through eyes; striated curls hanging over forehead; high, conical head-dress with a frontal design, now missing. Height 18.0. No. 544 found in XXV, at level 102.0; No. 570 in XXX.
571. Loom-weight of terracotta, as No. 559. Diam. 7.1. II, tomb below floor.
572. Loom-weight of terracotta, as No. 550. Length 7.6. II, tomb below floor.
573. Loom-weight of terracotta, as No. 559, but thicker. Diam. 4.2. II, tomb below floor.
574. Black Lustrous II bowl with raised base-ring; curved sides; inturned rim. Dull, black glazed inside and partly outside. Diam. 12.4. II, below floor.
575. Wheel-made terracotta lamp; somewhat raised base-ring; narrow filling hole; horizontal nozzle; pierced knob on right side of body. Length 6.1. XXX.
576. Moulded terracotta lamp with flat base; wavy knobs on rim; volutes on nozzle. On discus, two clusters

- of grape in relief. Part of lamp missing. Length 8.1. XXV, deposit.
577. Moulded terracotta lamp, flat base; vertical, pierced handle; small, triangular nozzle; impressed leaves on rim; on discus, peacock seen from in front with outspread tail. Length 9.2. XXV, deposit.
578. Miniature terracotta jar; curved sides; two knobs on the side, as handles. Height 3.3. XV, level 110.0.
579. Loom-weight of terracotta as No. 550. Length 8.3. LIV, below floor.
580. Loom-weight of terracotta, as No. 550. Length 7.5. LIV, below floor.
581. Loom-weight of terracotta, as No. 559. Diam. 7.5. LIV, below floor.
582. Loom-weight of terracotta, as No. 558. Diam. 5.0. XLII.
583. Loom-weight of terracotta, as No. 558. Diam. 7.3. VIII.
584. Loom-weight of terracotta, as No. 550. Length 8.3. XV, level 122.0.
585. Loom-weight of terracotta, as No. 559. Diam. 7.6. XV, level 120.0.

CLASSIFICATION OF FINDS

Pottery (Pls. CLXXVIII, CLXXIX).

Up to date, there does not exist a proper classification of the Cypro-Hellenistic and the Cypro-Roman pottery. The few attempts at dealing with this chapter of Cypriote archaeology have not been brought further than, possibly, to separate the Hellenistic pottery from the Roman one. The various vases of the periods concerned have never been discussed and in the same way the chronological sequence and development of the different types and shapes have been neglected in literature. Gjerstad's classification of the Cypriote pottery is not carried further than to the Hellenistic period, as practically no material then existed on which a definite classification could be based. The task of doing this is very difficult, and problematic, as long as so few tomb groups are known. With the fragmentary material collected from the various strata of the Soli excavation it will certainly not be possible to follow all the faint alterations in the development of shapes and decorations as during the earlier periods. The following classification of the pottery is entirely limited to the Soli material and may serve only as a foundation for a more definite classification of all the Cypro-Hellenistic and Cypro-Roman pottery. As to the terminology it may be said that, as a general rule, the same system is adopted as in Gjerstad's Classification. This has proved to be very useful as regards the periods it deals with. The main groups of the classes are kept apart by means of the different names of the classes, and the variations which can be distinguished within the groups are indicated by Roman figures. Later on will be discussed, how these vase classes are distributed between the various strata. It is true that some of these classes are known from other sites. In some cases they are called in literature by names usually referring to the localities where the pottery first was found. In other cases, the origin of the pottery has been traced with some degree of certainty and it has been called after these localities. This holds good as regards some of the red wares which are called Pergamene or Samian, etc. As to the Pergamene ware it is recorded from many a site of Hellenistic date such as Priene, Athens, Corinth, Samos, and Olbia and it certainly will appear in others, too. The Pergamene origin of this pottery, however, is not definitely settled, especially as the ware not is characteristic of Pergamon itself. The question of the so called Samian

ware remains in a similar state. This kind of pottery has been found at many places in Greece and Asia Minor and its Samian origin may well still be doubted. In any case it seems safer not to accept a terminology based upon mere suggestions as to the origin of the pottery. In the following pages the wares are distinguished and their characteristic features serve as foundation for the terminology.

Black Lustrous I Ware.

Technique.

This ware is wheel-made and shows a highly developed technical skill. The technique is entirely dependent on the Black Glazed Ware of the Late Classical Period. The clay is always well silted and hard baked; red in colour. On the clay is applied a very glossy, lustrous glaze sometimes with an iridescence of blue. In most cases the glaze has remained intact. As a rule the glaze covers the whole pot but sometimes horizontal encircling lines are omitted. On such parts the red clay is visible. This pottery is well paralleled from other Hellenistic sites (cf. below).

Shape.

The most frequent shapes are bowls usually shallow and sometimes very large; with a high base-ring; curved or angular sides and plain rim. Other bowls have a wide base-ring almost horizontal sides and wide, downturned rim; in the centre, there is a curved depression. Only few sherds of jugs are represented. Sherds of the lower part of the body are preserved, on which carefully fluted grooves are noted. There are also fragments of large amphorae the shapes of which cannot be determined. Fragments of very large lamps are noticeable, with a thick short nozzle. (Fig. 280, 1—3).

Decoration.

As a rule this ware is undecorated. On some specimens of the bowls, the bottom is decorated with impressed ornaments of which palmettes are the most frequent.

Black Lustrous II Ware.

Technique.

This ware is wheel-made, sometimes worked over subsequently; in some cases the bodies of large amphorae are vertically grooved or have impressed ornaments on the rim. The clay is grey or brown and differs from that of the Black Lustrous I Ware, which is red. It is not so hard as the latter and shows in general an inferior quality. The lustre, too, is inferior in comparison to that of the Black Lustrous I Ware. It has not the same shiny surface, but is nearly mat and sometimes rather coarse. Though it has not the deep black colour of the previous ware it still is black or slightly mottled into red. As a rule, the lustre does not cover the whole vase: on the bowls, as a rule, the whole inside but only the upper part of the outside is covered, the base being plain. On larger vases, e. g. the amphorae, the bases also are



Fig. 28o. Soli. Sections of pottery sherds.

lustrous. Usually the surface is well preserved but sometimes there are a great many diminutive patches worn off. This is probably because the lustre is very thin and the clay not so finely silted.

Shape.

As regards the shapes, this ware is characterized by a clear degeneration of the previous ware and it is sometimes difficult to make clear distinctions between the two classes. The shapes show a good many varieties. Some of the bowls, of small size, are of the same type as No. 574: small thick base-ring, curved sides and inturned rim. Other bowls are more shallow and provided with a very small depression in the centre, the sides are straight and the rim swollen. In a few cases, a thick horizontal handle is noted on bowls with angular outline and raised rim. Another type of bowl has slightly curved sides and sharply inbent rim. A peculiarly shaped handle is found on open bowls with somewhat moulded rim. The handles are placed horizontally just below the rim; the middle of the handle is depressed against the rim so that two loops arise. The jugs are of various shape. Common are the so called tear-bottles with diminutive base, spool-shaped body, and narrow, concave neck. There are also fragments of depressed globular jugs with raised base-ring, narrow concave neck and cup-shaped rim, a type which seems to have developed from the Cypro-Classical lekythos. Another variation of the same type is ovoid in shape and provided with a very small base-ring. The neck is narrow. As far as can be stated there are no fragments of jugs of large size. The shape of the amphorae can not be entirely determined, as the fragments preserved constitute too small portions of the vases. They probably had a foot; the sides are bulging; the gentle neck was finished in a softly splaying rim. The vertical handles run from rim to shoulder. Whether there also was a type with horizontal handles could not be ascertained. (Fig. 280, 4—9).

Decoration.

The Black Lustrous II Ware is usually undecorated, but sometimes there are decorations of two kinds: amphorae are decorated with impressed, ovule ornaments on the rim; around the shoulder there is sometimes a frieze of vertical grooves. White supplementary colour is also used as decoration on the neck and around the body; the motives are usually a wreath of ivy-leaves, sometimes combined with an incised design. Similar incisions are in a few cases found inside the bowls. Other bowls are horizontally grooved.

Mat Black Ware.

Technique.

This ware most likely constitutes a development of the previous ware. The degeneration of the ware is carried further, but this holds good only as regards the lustre which here is merely a slip. The clay is good and rather hard; sometimes the walls of the vases are very thin, especially on some of the cups. As a rule, the clay is grey, on rare occasions chang-

ing to pale red or pink. The lustre of the surface has entirely disappeared. The slip is mat. A characteristic feature is that the colour of the slip is no longer so well defined as on the previous vases. The slip is only rarely definitely black; usually it is grey, sometimes it is mottled to red or dark brown, in which case the ware comes near the Mat Red Ware. On some fragments the inside of the vase, usually a bowl, has got a red slip and the outside a black.

Shape.

The shapes of this ware are as a rule developed from the previous ware. The plates or bowls with straight sides known from the Black Lustrous II Ware have the rim somewhat downturned. The mouldings at the rim differ, too, so that the original prototype of the Black Lustrous I Ware now is hardly to recognize. Other bowls are cup-shaped, angular and provided with vertical knobbed handles. The most typical bowl of this ware, however, has a small base, sloping sides, a sharp ridge around the side which separates the somewhat curved, vertical rim from the lower part of the bowl. This type has a small vertical handle on the rim. The type seems to have developed also in Black Lustrous II Ware, but there the rim is very short and more curved. Another type of bowls is shallow and has curved sides with a plain rim.

The jugs do not show so many types. Some of them are oval in shape with a gently tapering shoulder and splaying mouth. Some of these jugs are very carefully made while others show a coarse technique. The handle is carelessly placed on the shoulder from the neck.

Decoration.

As a rule, this ware is undecorated, but some of the bowls have incised, encircling lines around the sides.

Red Lustrous I Ware.

Technique.

This ware is wheel-made. It is entirely different to the Black Lustrous I Ware and should not be confused with that. The clay is buff or light red often not very hard baked. It always keeps the same colour all through. The walls of the vases — even vases of larger size — are thin. There are, however, some bowls or plates with very thick bottom. On the inside of jugs and amphorae there are often very distinct marking of the potter's hands when turning the pot on the wheel. The lustre is light red and shiny. It is always darker than the clay of the pot and, as a rule, it covers the whole surface, even below the base. Usually the lustre is well preserved but in cases when it is worn, it appears rather mat due to the great many diminutive, small patches where the clay is visible through. The impressed ornaments are very shallow; almost impossible to indicate by means of a photograph.

Shape.

Characteristic of this ware is a very thick and large plate on a high, wide base-ring and angular outline. Another kind of plate has no base-ring; upturned, thickening rim. Well

defined fragments of shallow bowls or plates have a very angular outline, horizontal, flat bottom on a wide base-ring and encircling ridges around bottom and rim. On similar plates the base-ring is missing. As to the bowls there are several types: many kinds of cup-shaped bowls with handles and more or less angular outline. A comparatively deep bowl has round bottom; gently curved sides, and somewhat stilted rim. It must be pointed out here that the Red Lustrous I Ware has very few shapes common with those described under the Black Lustrous I—II Wares. The bowls so peculiar to the Black Lustrous I—II Wares are entirely absent here.

As most of the jugs are broken into very small pieces it is practically impossible to determine the shape of any of them. One kind of amphora had angular outline; ridge on shoulder; cylindrical or slightly tapering neck with somewhat moulded rim; vertical, grooved handles from neck to shoulder. (Fig. 280, 11—16).

Decoration.

This ware is never painted. Some of the bowls, however, are decorated with impressed patterns. These are usually very minute and carefully made. The motives are ovules around the rim, bands of parallel lines framed by encircling lines, the whole encircling the centre of the bottom. This decoration is found on some of the plates. The bowls with hemispherical bottom are sometimes grooved on the outside.

Red Lustrous II Ware.

Technique.

As far as can be ascertained this ware constitutes a continuation and further development of the Red Lustrous I Ware. The clay does not differ from the clay of that ware but there is a distinct change as to the lustre. The shiny lustre is no more there. The surface is not so glossy or carefully worked. It gives a coarse impression when touched with the fingers. Generally the lustre is thinner; sometimes the traces of the brush are noted as darker or lighter patches. The colour, too, has changed. Besides the light red there are many sherds of dark or light brown colour, sometimes mottled to black. Only on rare occasions the base has been slipped on the underside.

Shape.

This ware shows a great many varieties as to the shapes of the pots. The extremely angular plates of the previous ware seem not to be common in the Red Lustrous II Ware. Some plates have no base-ring but wide, flat rim. Another kind of plate with upturned, somewhat curved rim shows many variations. A very shallow bowl with base-ring; straight, almost horizontal sides, and swollen rim is known from the Black Lustrous I—II Wares and the Mat Black Ware where the whole development of the type can be studied. The same can be said of the bowls of the same shape as No. 574. Though relatively rare the shape is known in this ware, too, sometimes the outside of the bowl is mottled to black, while the inside

has the characteristic Red Lustrous surface. Another kind of bowl has a base-ring, curved sides, and out-turned rim. In several layers, fragments of large, deep bowls were found which have a moulded, depressed rim, rather wide; somewhat angular sides. The jugs have usually a tapering, narrow neck with annular rim and sloping shoulder. As a rule, the vertical handle is grooved at the middle. (Fig. 280, 17—22, 26—31).

Decoration.

This ware is decorated with incisions or paintings. On rare occasions both kinds of decoration are used together. The incisions mainly consist of bands of short lines or notches which encircle the body of the vases both on bowls and jugs. These notched patterns are of various design and mainly to be found on large bowls and jugs; either short, rather careless notches on the surface or chains or groups of parallel lines. As a rule, they are localized to the outside of the vases, but on some of the large shallow bowls or plates the patterns are found on the bottom, inside, in a way which reminds one of the impressed patterns of the Black Lustrous I Ware. Some fragments show that there existed bowls with grooved outsides. The painted decorations are made in white, supplementary colour sometimes designed by means of incisions made after the baking. A few fragments of bowls have a dotted line in white paint just below the rim, on the outside.

Mat Red Ware.

Technique.

This ware might be a further development of the previous ware, though the changes in many respects are very distinct. The vases are always wheel-made. The clay is hard and grey in colour sometimes changing to buff or pale red. The walls are thin and no large vases are represented. If the clay cannot show any features indicating a definite change from the clay of the Red Lustrous II Ware the slip, however, is easily distinguished from the slip of that ware. The surface is now entirely mat covered by a brownish red slip, usually very thin, but sometimes thicker. The colour is always mottled, from patches of dark brown to light red. Often there are a great many small patches worn off the slip, patches where the colour of the clay comes through. It is noted on many sherds of the bowls that the inside colour is not exactly the same as that of the outside, which often is somewhat lighter. Due to the brownish tint of the slip, this ware sometimes is difficult to distinguish from the Mat Black Ware which also has a brownish colour.

Shape.

As regards the material concerned, the shapes associated with this ware are very few. A kind of cup with small base-ring, sloping, almost straight sides, vertical, somewhat convex rim which starts with a sharp ridge encircling the side of the cups are paramount. Just above this ridge, there is a vertical loop-handle with one or two flutes in the middle. A similar kind of cup has no ridge on the side, but otherwise an angular outline. Sometimes they are

provided with one or two grooves below the rim. The sherds which can be attributed to the jugs are very small and no distinct shapes can be made out. (Fig. 280, 23—25).

Black Polished I Ware.

Technique.

As this ware is represented only by a few fragments one is chary in making general suggestions as to the nature of the ware. The fragments in question have a grey clay, very finely silted and rather soft in comparison with the hard Black Lustrous Wares. On both sides, the vases are covered with a black slip which is polished to a highly glossy lustre. Thus the ware gives the impression of polished ebony.

Shape.

Only bowls are represented as regards this ware. One of them is shallow, with angular outline and moulded, out-turned rim. This is of a rather thick ware. Another type of bowl has softly curved sides, and plain rim. Just below the rim, there is a ridge on the outside; on the inside there is a corresponding groove. Whether these bowls were provided with handles or not cannot be ascertained as no traces of handles were found. (Fig. 280, 32—34).

Decoration.

The ware is decorated with incisions only: encircling lines and bands composed of small impressions of various kind. The inside is plain as regards incisions but there, a kind of pattern is obtained by means of a certain gradation in the polish so that some mat lines make a contrast to the polished rest of the wall.

Black Polished II Ware.

Technique.

This ware, too, is represented only by a few sherds. It is similar to the Black Polished I Ware but shows some typical distinctions. The clay is grey, finely silted and rather hard baked. The black slip, however, has not the glossy lustre of the Black Polished I Ware; it is half mat or even mat but very smooth on the surface which is perfectly well preserved.

Shape.

Only one kind of bowl is represented, known from the Black and Red Lustrous II Wares as well as from the Black and Red Mat Wares: angular outline; vertical rim which starts from a ridge which encircles the side (Fig. 280, 35)

Monochrome Red Ware.

Technique

This ware should not be confused with the Red Lustrous I or II Wares though, at the first glance, the two are rather alike. While the clay of the Red Lustrous Wares always is

buff or light red, this ware shows a brick red clay. It is of almost exactly the same colour on the surface and all through. On the surface there is no mat slip or glaze; the surface has only been washed over. The surface is not lustrous but in a peculiar way half mat, as if had it been covered with wax. The clay is very hard and extremely well silted. All the pots seem to be wheel-made. A characteristic feature of the vases may be mentioned: on the outside, usually near the base, there are some faintly visible traces of the potter's hand in shape of thin, very regular ridges encircling the body, the rest being carefully smoothed by the wash. The rim of the bowls are either vaguely modelled or moulded, with distinct edges and sometimes provided with incised encircling lines.

Shape.

Bowls and plates only are represented. The plates have wide, low base-ring, and curved upturned sides with flat rim. The bowls can be classified in generally two types: one of them is rather primitive in shape with flat base; no base-ring; the sides rise gently from the bottom without marked edge; the sides are widening upwards and the rim is plain. The other type is like the plates but deeper. No fragments of handles of any kind can be ascribed to this ware.

Decoration.

Besides the encircling, incised lines mentioned above there is no decoration on this ware.

White Painted Ware.

Technique.

Besides a few fragments of Early Iron Age White Painted pottery which are explained as accidental stray finds, a small amount of Hellenistic White Painted Ware was found. They are similar to the White Painted VII Ware and most likely constitute a continuation of this. The clay is coarse, rather soft; it breaks easily in small pieces. The outside is washed white. In comparison with the great amount of sherds of other classes this ware plays no role for the whole material.

Shape.

As all the pots of this ware are broken in small pieces no shapes can be determined. Judging from the sherds, however, the vases must have been of large size. The sherds might have come from amphorae or hydriae.

Decoration.

On the white wash, encircling bands were painted. The bands are brown in colour and the paint is mat and rather thin.

Grooved Ware.

Technique.

Under this heading, various kinds of pottery are described which, however, have a common characteristic treatment of the surface: it is grooved in horizontal lines; either

wide grooves at some intervals from each other or more or less incised lines close together. The former kind is most frequent. Possibly the varieties mean nothing but a gradation of coarseness. Some of the fragments are very coarse and must be parts of large vases with a thickness of the walls of more than 1 cm. Another kind is very hard baked and dark in colour giving a metallic impression. As a rule, these are comparatively thin.

Shape.

No definite shapes can be described. Mainly amphorae are represented with more or less rounded base, somewhat concave sides; angular shoulder, and narrow rim. There are fragments also of amphorae with long neck and flat rim. (Fig. 280, 36).

Decoration.

Besides the grooves described above there is no decoration on this ware.

White Slip Grooved Ware.

There are a number of sherds of the Grooved Ware covered by thick white slip which sometimes is partly worn away.

Plain White Ware.

Technique.

This ware is generally represented by large vases, bowls, jugs or amphorae. The ware does not differ from the Plain White VII Ware of the Late Cypro-Classic period. It is hard and sometimes rather coarse. As a rule, the clay is of the same colour all through: buff, greenish yellow or pink; but sometimes the outside of the sherds is light-yellow while the inside is pink or red. Usually the vases are washed over in some way sometimes with a very thick wash.

Shape.

As most of the fragments of this ware originate from large vases which are broken in small pieces it is practically impossible to determine the shape of any complete vases. Though the upper part of a vase often can be determined, it proved very difficult to find the lower part and vice versa. The following shapes are represented: bowls, jugs, and amphorae with flat or pointed base. The bowls are of various kind. A simple type is very shallow, with a small base; the sides splay almost horizontally; the rim is plain. There are no remains of handles belonging to these bowls. Other bowls are deeper. A common type has wide, flat rim and large, horizontal handles. On other bowls, wide handles are placed on the very rim, which is marked with mouldings. Often shapes common among wares, e.g. Black or Red Lustrous II Wares and Black or Red Mat Wares, are found among the Plain White Ware. Thus the shallow bowl with almost horizontal sides and moulded rim is noted, also the shallow bowl with high base-ring and angular outline. The shapes of the jugs, too, are

known from the previous wares. The ovoid jug with sloping shoulder, almost cylindrical neck, and flat, out-turned rim is common. Tear-bottles are also found. Sometimes the jugs have a considerable size and the twin-handle seems to be paramount as regards the jugs. Most of the sherds, without comparison, come from amphorae which on rare occasions have flat bottom. The amphorae with pointed base are by far the majority. A great many base-knobs are preserved showing some variations. Most common is a knob shaped as a spindle-whorl turned upside down and with a deep depression from below. A variation of this is more disc-shaped and provided with either a small depression from below or a faint boss at the centre. A third rather common type is thick and has cylindrical or slightly convex sides. The base is flat or somewhat concave. None of the amphorae have a long, pointed body but they seem all to be rather squat and rounded. The necks are either short and slightly concave or long and cylindrical; the latter shape has sometimes grooved sides. On amphorae with long neck the handles, as a rule, are sharply bent near the rim and sometimes provided with a stamp impression. (Fig. 280, 37—39).

Decoration.

The Plain White Ware is decorated only on rare occasions. A peculiar kind of decoration is made by means of relief-bands laid in wavy lines. Sometimes they are ended with snakes' heads. Other vases are decorated with small impressed circles.

Coarse Ware.

Technique.

This ware constitutes a very great part of the whole material of sherds, and many varieties as to the baking and shapes are noted. As a rule, the vases are rather thin and very hard. The colour changes from black to dark brown.

Shape.

The Coarse Ware usually varies very little from time to time and the same shapes are often used during long periods. In the material concerned here, however, it is possible to demonstrate a certain development of some of the types. We start with a bowl with flat base; straight sides, widening upwards, and flat rim. This bowl has a small handle shaped as a depressed loop placed just on the rim. This is the first stage in the development. Next stage is marked by the loop being depressed and elongated so that the handle now is like a straight, flat pin. The last stage of the development shows a straight handle with a ridge along the handle which is pinched out at the end to two horns. This development is demonstrated by the stratification. Other bowls have flat base and angular outline. The same shape is known from the Mat Black Ware. The cooking-pots have a well rounded body, sharply angular rim, and handles with circular section. The jugs and the amphoriskoi show a great many varieties of the same type. As a rule, they have flat base, ovoid body, wide, raised rim, and vertical handles. Some squat amphoriskoi with wide rim have rather wide, horizontal handles with circular section. (Fig. 280, 40—43).

Sculptures

Marbles.

Material.

All Cypriote marble sculptures are probably made of imported material. According to geologists, however, there exists a kind of local marble in the mountains above the village Bella Paise, but it is not likely that this spot was quarried in ancient time. There are no signs of ancient quarries. The marble used for the Soli sculptures, as for other marble sculptures found in Cyprus is coarse grained. In some cases, the marble is very hard and white in colour. Sculptures made of this kind are very well preserved as regards the surface, e. g. the Aphrodite head No. 438. Sometimes faint grey or blueish veins can be seen in this hard marble. Another kind is still coarser, but not of the same density. The surface crumbles easily and whole crystals can be picked out of the core. This loose kind of marble has, at least, in some kores e. g. in No. 497, a yellow colour, but in other cases, the soft marble can be white or blueish white. Usually the patina is yellow owing to the red earth in which they were found. It is true that the layers in the temple site where these sculptures were found, were not of the very red kind of earth noticeable over vast areas of Cyprus, but still the earth has affected the marbles in the same way as does the red earth.

Technique.

Judging by the material from Soli no very large pieces of marble have been used for the sculptures. Usually the heads, often even the small ones, were made separately from the body and fitted to it by means of an iron pin, or simply sunk in a depression on the body. In the same way, the statue was placed on the base. It is also worth noting that the marble statues very often had to be mended either before they were finished, or after they for some reason had been broken on the temple site. Even very small pieces have been mended. A deep hole was bored on both sides of the fracture, which is not usually levelled or filed off. The two broken pieces have been fixed together with an iron peg of suitable size. The iron is sometimes fixed to the marble with lead which has been melted into the hole around the peg. Often the iron has oxidized and given a red tinge to the marble, sometimes visible on the surface as a red or brown patch. On the small head No. 416, this spoils a good deal of the expression of the face. On the same head, too, it can be seen how the oxidized iron can cause cracks in the marble. — The treatment of the surface of the marble varies on different sculptures. Sometimes the drill is used to a great extent for instance in the hair, for modelling the ears, the mouth, and the nostrils. With the exception of the Agrippina portrait, however, deep borings are never used as a *decorative* element. On the head mentioned there is a deep bored puncture in the centre of all the small curls on the sides of the head. There, the borings must be intended as a stylizing of the hair-dress. This head is, however, through other features different from the rest of the marble sculptures. As regards these, the drill is entirely used as a technical help for excavating the deeper parts of the sculpture, and without any thought for the decorative effect. Usually the artist has tried, at least on the

better sculptures to remove all traces of the drill, which, however, in many cases can be noted at the corners of the mouth, behind the ears, and sometimes in the hair. This different use of the drill seems to be a good help for dating the sculptures, which will be dealt with in a later chapter.

The smoothing of the surface also varies on different sculptures. The surface of the big sculptures is never polished, but finely smoothed. It is always more or less mat. The same treatment is noted also on most of the small statues. Some of these are rather roughly smoothed, as for instance No. 466, where, on the left side and part of the back, the fine grooves or traces of the tool can still be seen. On the left side, at least, the definite finish of the surface was connected with certain difficulties, for, evidently, some object was placed close to the body on this side. Only in one case, Nos. 416 + 463, all the surfaces representing the skin have been carefully polished. The hair is marked by fine grooves made by the drill, and this part is not polished.

It is evident that not all sculptures are meant to be seen from all sides. Thus the large head No. 438, is entirely unsculptured at the back. The almost flat back surface was probably fixed to a wall or the like, as a strong iron rod is broken off on the back. The small statuette, No. 497 was also hardly intended to be seen from the back, and this side was therefore rather neglected by the artist. Another arrangement is noted on the head No. 425. There, though not broken off, the nape of the neck is entirely missing from an oblique line through the head. The surface of this side is roughly grooved with a tool and no other piece of marble can have been fitted to this surface. Possibly the occiput and the whole back of the head was made of plaster and added to the marble face. The same technique has been observed on other heads, especially from Alexandria.

Painted Sculpture.

Probably, most or all marble statues once were painted. The colours, however, have usually disappeared, or are so faintly preserved that one can hardly get the original expression of the sculptures. Red seems to have been predominant, used both for the hair and other parts of the body. A characteristic feature of the Soli sculptures is that neither iris, nor pupil are marked in any way by sculpturing, as for instance by an incised line. Therefore, it is natural to suppose these parts of the eyes were marked by paint. The same is peculiar to all periods of Cypriote sculpture. The painted iris can be seen only on one specimen of the whole series *viz.*, No. 438. On this head the colour was so faint, that it was hardly possible to define it as anything but dark paint, possibly blue or *terra umbra*. Other parts, which were usually provided with colour are the hair. In many cases, it could be ascertained that the lips were painted red and that the colour of the hair on female heads was red. This is not in accordance with older styles of Cypriote sculpture, where the hair, as a rule, is painted black. Most likely the red-haired type has been introduced from Alexandria, where a good many of the Hellenistic female heads have the red colour preserved on the hair.

Other parts, too, of the sculptures were painted. To continue with the female, traces of red paint was noted on the genitalia of the small statuette, No. 466, when this statue was

excavated. As often, however, the colour disappeared after a short time in open air. The flames of the torch, No. 464, were painted with a bright red colour. — To sum it up can be said that paint was used on certain parts of the marble to exaggerate the effect of the sculpture.

Alabaster.

Material.

It is impossible to state if the alabaster sculptures are made of the same, or different kind of alabaster. Possibly their state of preservation, which varies very much, is due to special circumstances in the earth. The various pieces of alabaster may also be more or less sensitive for the destructive acids in the earth. The larger sculptured statues of alabaster were so completely destroyed on the surface, that their original shape could only be conjectured, if the pieces were compared with other statues of a similar shape made of other material. Other statues, or pieces of statues, seem not to have undergone any change during the long time in the earth. The alabaster is of a white or bluish-white colour. The badly destroyed pieces entirely reduced on the surface, are covered with a thin layer of white stuff which easily comes off. This patina has destroyed the transparency of the alabaster.

Technique.

The Hellenistic sculptures of alabaster are usually made in a rather clumsy technique, and the same can be said concerning the Soli specimens as far as the material allows an estimation. The pieces of upright statuettes are all very flat. The technique in general seems not to differ from that of other alabaster sculptures to be found in the museums in Alexandria and Nicosia.

Soft limestone.

Material.

Already in the Archaic period the very soft limestone was used for sculptures especially those of smaller size. Among the sculptures from Vouni and Mersinaki many of the best specimens are sculptured of this kind of stone, which probably was quarried at Paradisotissa, west of Vouni. The consistence of the soft Paradisotissa stone varies very much from time to time. When dry and fresh quarried it may be considered a fairly good stone for a sculptor. Probably it was chosen on account of its white colour. It was easily worked to sculptures with minute details, and the paint made a good contrast to the firm, smooth and white surface. It has, however, one feature, which for the excavator is very unfortunate: it is not durable. After a long time in the damp and moistened earth, the stone becomes so soft that it can be compared with very soft cheese, or even *yoghurt*. It has a very fatal tendency to scale off in many thin slices which makes it almost impossible to take up the complete statue from the earth. With great care it can be cleaned *in situ* in the earth and sometimes removed, but in bad cases, after a time in the open air, the whole piece falls into a powder in spite of everything being done to preserve it. This is especially the case when roots of plants and trees have penetrated into the statue between the slices mentioned

above. Supposing that the various pieces of a statue have been removed and thoroughly dried separately, it is often impossible to stick them together because the different pieces have subsequently lost their original shape, been deformed to such a degree that one hardly can believe that they originated in the same statue, and that the fractures once have fitted close to each other. This characteristic makes it sometimes impossible to state with certainty whether two pieces of statues, e. g., a head and a body belong to each other, or even whether the original fractures are preserved or not. Such are the characteristics of this stone, and to make sure of any results it is always advisable to make all notes, descriptions and photography before removing the sculpture from its position *in situ*.

The variety of the stone used in the Soli sculptures is white though with a slightly yellowish tint. The Cybele statue, No. 446, was so badly destroyed that, though everything was done to preserve it, it crumbled into a heap of small pieces and dust, when removed.

Painting.

In resemblance with the archaic statues of soft limestone, the Soli statues probably had painted details. In no case, however, the painting was preserved owing to the fact that the surface of the Soli sculptures of soft limestone was in all cases worn away.

Hard limestone.

Material.

This material was hardly ever used for sculpture in the earlier periods of Cypriote art. In both archaic and classical times, the limestone used was of a much softer kind though hardly comparable with the stone described above as soft limestone. The earliest statues of the really hard limestone, found in Mersinaki, can be dated to the era after Alexander the Great. The stone concerned is very hard. It contains great masses of small, petrified shells of various kinds and is in this respect not unlike the Nummulitic limestone used for many sculptures in Alexandria. The Soli stone, however, is usually not white but grey and the patina which time and the earth have given to the sculpture in this limestone is so faint that it sometimes can hardly be noted. Like the Nummulitic limestone, the Soli stone also contains masses of small holes and cavities which prevent the sculptor from getting the desired smoothness of surface. Sometimes, though more often in Mersinaki, than in Soli, destructive chemical processes have begun in these cavities and spoiled the surface. This extremely hard, coarse-grained limestone must have been very difficult to work and perhaps the material has caused the characteristic stiffness which is peculiar to some of the sculptures, and noticeable especially in the details.

Technique.

As the hard limestone was used during several periods it is natural that various techniques of sculpture are found among the statues in this material. As regards this difference, reference will be made to the characteristics of the various styles of sculptures made of hard limestone.

Painting.

Only occasionally are traces of paint preserved on sculptures of hard limestone, as for instance on No. 420, where red paint was noted on the hair of Eros. Probably however, the sculptures were usually coloured, though on account of the coarse-grained stone, it has disappeared.

Styles

M a r b l e.

Style I A (Nos. 425, 447, 457, 532; Pls. CL, CLI).

As regards the marble sculptures two groups may be distinguished which show stylistic as well as technical differences. The two groups are here called Style I A and I B. Style I A is characterized by an extremely soft treatment of all the details of the face. There are no marked lines, such as accentuated ridges in the sculpturing of the eyes or the lips. All the planes are softly melted the one into the other. The eyes are deep looking but on examining how this effect was obtained, it becomes clear that the eyes are not sculptured deep. It is more or less the mere expression of them which makes the effect. It seems to be one of the most characteristic features of this style that all prominent or deep details are avoided. The mouth is indicated by a shallow, wavy line. The nostrils are marked as faint depressions. All the distinct contours are absent. Thus any kind of exaggeration was absent in the artists' minds. They wanted to obtain the expression of the sculptures by means of a very faint and delicate modelling. In comparison with other Cypriote sculpture which always shows more or less conventionalized features, this style bears strong marks of realism, which, no doubt, is due to Greek-Hellenistic influence. Technically, there are some features characteristic to the style: the drill seems to have been used only on rare occasions and, as a rule, the traces of it have been carefully removed. This is noted on details where traces of a drill could be expected, as on the hair, between the lips, etc. Sometimes the head was made separately of the body and placed into a depression on the upper part of this; but usually the figure was sculptured of a single piece of marble. On some sculptures certain less important parts were supplemented in plaster. This might be the case with No. 425 on which the back of the head is not broken off but roughly levelled by an instrument.

Style I B (Nos. 415, 416 + 463, 417 + 437 + 464, 438, 461, 466, 497, 511; Pls. CLII—CLVI, 1).

In many respects this style is different to the previous one though the close relationship of the two is evident. The outline of the faces are sometimes similar; the same broad base of the neck appears in both styles; the Greek-Hellenistic realism cannot be denied having given both styles their general features. But still the way of sculpturing many details separates the two clearly. While all the elements of the face in Style I A were worked with a delicate softness so that all the distinct lines are avoided, the delineating character of Style I B is

clearly expressed. Take the head No. 438 and compare it with the most typical head of Style I A, No. 425. All the contours are distinct; the eyebrows and eyelids are skilfully sculptured but the somewhat stiff and sharply marked lines impart to the head a rather dry expression which is entirely absent as to the head No. 425. All the elements of the face are distinctly kept apart. The drill has often been used in Style I B. This is noted on many parts of the sculptures. Thus the lips, the nostrils, and the ears could not have reached their present form without the drill. There is also a certain change as to the outline of the heads. Those of Style I B often seem to be more oval, fuller, which is noted especially on the lower part of the faces. For a more detailed discussion of these types of heads reference is given to a subsequent chapter dealing with the chronology of the sculptures.

The Agrippina head No. 414 (Pls. CLVI, 2—CLVII).

This head stands out as something quite different to all the other sculptures of this site. The place of the head in the series of other, previously known portraits of Agrippina will be discussed later.

Soft limestone (Pl. CLVIII).

The sculptures of soft limestone are all placed in one group as they are but few in number and display an undeniable conformity as to their style. There is however, one exception which should be kept apart, No. 336. This fragment of a male votive statuette belongs to the old Cypriote tradition of plank-shaped sculptures. It can be compared with Mersinaki sculptures of Style IV which represent the very last stage of a long development of stylistic degeneration. The rest of the sculptures in soft limestone are more or less influenced by the new styles in marble and hard limestone (Styles V and VI in Mersinaki). It is thus interesting to find, that the soft material in Soli survived after the change of style which, as regards the Mersinaki sculptures, is marked by the change from soft to hard material, because, stylistically some of the Soli sculptures in soft limestone are closely connected with the Style VI of Mersinaki. The existence of the new aims is clearly expressed by Nos. 419 and 446. The comparatively realistic dress of those sculptures and the elegant attitude of the same place them definitely in another group than the sculptures of Style IV from Mersinaki. No. 419 represents a flattened type which is characteristic of Style VI of the same Mersinaki series. There is no reason for a suggestion that these sculptures should not be contemporary in spite of the important difference as regards the material.

The head of Isis, No. 314, is outstanding already on account of its large size. The material is not of the very soft kind which is characteristic of the other sculptures of this group, but it cannot be compared with those of hard limestone. The style of the head should be judged with regard to its large size. Otherwise many of the details will not have their right explanation in comparison with other sculptures of minor size. The sensible and carefully sculptured mouth, the dimple at the centre of the chin, and other rare features of Cypriote sculpture

would not be expected on minor sculptures. The type of the face and the treatment of the surface are of similar kind as regards the Style I B of the marble sculptures. The same features are characteristic of the small head, No. 443, too. Thus the groups of sculptures in soft limestone, with the exception of No. 336, find their closest parallels stylistically, in the Style I B of sculptures of marble and, which will be shown below, also of sculptures of hard limestone.

H a r d l i m e s t o n e .

The sculptures of hard limestone show a great variation as to their styles. Four main groups or styles are easily distinguished, the characteristic features of which will be described on the following pages. But, I think, it is possible to trace a certain development also within some of these main groups. This holds good especially as regards the first style, the nature of which is more or less naturalistic, dependent on Greek-Hellenistic sculpture styles. As comparatively few close relations to other countries are found as to the subsequent styles these are considered to be of a more local Cypriote character. The whole series, however, will be treated as being representatives at various stages of development of one and the same local sculpture tradition. The continuation of the development can also be demonstrated at least at the beginning. Below (p. 533 ff.) it will be shown how the sculptures of the various styles were found at various localities within the excavated area and how they can be connected with the different temples of the whole block of building.

Style I A (Nos. 413, 502, 507, 508, 518, 519, 533, 535, 536; Pls. CLIX, CLX).

This style is most closely connected with Style V of the Mersinaki sculptures. There can be little doubt that the Soli sculptures of Style I A and the Mersinaki sculptures of Style V originate in the same workshop, especially as the two places are situated within a mile's distance from each other. All the sculptures from Soli, belonging to this style, have suffered severely by corrosion, which has left only the outlines of the faces with their deeper parts. The prominent portions are, as a rule, worn off the specimens. It is possible, however, in spite of the destruction, to recognize the soft treatment of all the details of the faces. The wide, somewhat prominent base of the nose, usual on Hellenistic sculptures, is recognized here as well as on the marble sculptures of Style I A. The fragmentary bodies, Nos. 507 and 508, may be ascribed to this style. They are both characterized by a vigorous, realistic style absolutely different to the usual Cypriote stylizing tendencies. The fresh motion of No. 508 is very rare in Cypriote sculpture even from this period which evidently is very much influenced from foreign Greek schools. The body of the sphinx, No. 536, is ascribed to this group, too, on account of its fresh realism.

Style I B (Nos. 339, 340, 410+411, 418, 439, 499, 517, 520, 521, 522, 530, 531; Pls. CLXI—CLXIII).

As the previous style could be connected with Style V of the Mersinaki sculptures this one finds its best analogies in Style VI of the same series. Evidently, Style I B constitutes

a further development of Style I A, but the fresh realism has gone: the whole attitude of the sculptures is stiff and clumsy; their bodies are flattened from in front; their backs are flat and unsculptured. As to the heads some remarks may be made. The same distinct way of sculpturing the details are noted as has been described under Style I B of the marble sculptures. The outline is oval with full cheeks; the eyes are comparatively small and usually very distinctly worked with somewhat pointed, sharp lids. The mouth is realistically worked and the line between the lips deeply cut. No traces of a real drill can be noted, but probably this instrument was used when sculpturing the deep parts of the curls of the Alexander head, No. 520. On the female heads, the melon roll coiffure is noted on two of the heads combined with a small cap, sitting vertically on the nape of the neck, with two ribbons hanging down (Nos. 517 and 522). On No. 521 the long hair is gathered in and kept loosely by a hair-net on neck. No. 531 has the hair combed backwards.

Style II A (No. 328; Pl. CLXIV, 1, 2).

The single representative of this style is characterized by the same features as the sculptures of Style VII of the Mersinaki series. This has been described as the exaggerated style. The coarseness of the technique has been pointed out as regards the Mersinaki sculptures. No. 328 is larger in size than those found at Mersinaki and the coarse characteristics are, therefore, still more outstanding. The nose and the chin are prominent, the eyes very deep and provided with bulging eye-balls. The vigorous outline of the face makes a queer impression at the side of the previously described sculptures. It seems, therefore, to be most natural to ascribe this head to a new, second style, the further development of which can be clearly followed in Style II B. In the same way as Style VII in Mersinaki indicates new aims and intentions of the artists in comparison with the development demonstrated by Styles V and VI, Style II A of the Soli series marks the start of a development on other lines than is expressed by Styles I A-B.

Style II B (Nos. 302, 317, 320, 427, 469, 534, 547; Pls. CLXIV, 3—CLXVI).

The vigorous and exaggerate style described above can be traced in Style II B in a very peculiar way. Though the bodies still are plastic, three-dimensional as in Style II A, the decorative details are designed on the surface of the bodies in a way which reminds one of the Cypro-Archaic styles of sculptures. At the side of the sculptures described previously, those of this style look very dry, being sculptured in a technique which is more in the nature of design. The curls of hair and beard give an impression of being made by some pointed instrument which had fluted, narrow, parallel grooves. The ridges between these always have a sharp edge. The same can be said about dresses and drapery. A certain stylizing can be noted as regards the forming of hair and beard on some of the sculptures. Thus the symmetry is clearly expressed in the beard of No. 469 and the hair of No. 320. The strictly frontal attitude of the latter head reminds one of the Cypro-Archaic styles of sculpture but it is hardly typical for the other heads of the Soli series. Nor does it occur as a characteristic feature of the later styles of the Mersinaki series, which are inspired by Greek-Hellenistic

sculpture centres. The explanation of this development may be the following: the Greek-Hellenistic sculptures, indicated by Styles V—VI in Mersinaki and Styles I A—B in Soli in some way ceased, so that the artists were confined to the local, Cypriote tradition of sculpture with features which, as has been pointed out, are characteristic of Style II B as well as of earlier Cypro-Archaic styles.

Style III (Nos. 301, 303, 311, 312—313, 316, 318, 334, 335, 338, 407, 509; Pls. CLXVII—CLXIX).

This style marks a definite change from Style II B. Differences can be demonstrated in the way of sculpturing most of the details. Some important marks should be noted which refer to the mere technique: all over hair and beard the drill is used frequently in a peculiar way. The various curls are formed by means of a chisel but in the centre of the curls or between them are deep holes made by the drill. They are of various size and depth due to the place where they are applied. These deep holes seem to have been used as one of the chief decorative motives. Sometimes the surfaces are very rough (No. 318); but often smooth surfaces such as faces and naked skin are polished in a characteristic way which imparts a certain effect to the rough limestone. This might be intended as an imitation of marble or porphyry. Stylistically a certain clumsiness is noted. The outline of the heads are rather vague and the detailed elements of the face show, though carefully worked, many conventionalizing traits. The eyebrows are always well accentuated, the eye-balls prominently globular, and the lids pointed elliptical.

Style IV (Nos. 319, 329, 342, 448; Pls. CLXX—CLXXII).

The sculptures of this style are characterized by a very crude technique. Possibly they show a development of Style III though the most characteristic features of this style are here entirely absent. The deep borings used as a decorative element can nowhere be recognized. The fine polish of certain surfaces of Style III can admittedly be noted here, too, but not in the same way. The coarse technique of some of these sculptures is in fact remarkable while the carefully worked, female statue, No. 319, in many respects displays a certain amount of actual knowledge. The decorations of the petticoat show some traits which are interesting from technical point of view. Some of the scenes are made *en creux* like Egyptian reliefs and as the scenes iconographically, too, are of Egyptian nature it may be ascertained that this technique has been inspired from Egypt though reliefs *en creux* are rarely found also on Cypriote sculpture of earlier date.

Terracotta (Pl. CLXXIII, 6—13).

All the terracotta sculptures are made in moulds. They are of common types with the exception of No. 544—570. This is of larger size than the others. The face was made in a mould but was worked over subsequently by means of a small pin with which the curls in beard and moustaches are modelled. As regards the minor terracottas several types are distinguished. 1. (No. 495). This is a comparatively early type known from various sites in

Cyprus. The mould is certainly prior to all the other sculpture finds. This type is solid, and flat on back. 2. Another type which also originates in a period before the Cholades temples were used, is represented by the seated figurine No. 498, with pointed Ionian hair-dress. To the same type the head No. 402 might be ascribed. This type is hollow, but has rather thick walls. 3. The bulk of the terracotta statuettes, however, are of the types usually known as Tanagra-figurines. (Nos. 426, 472, and 477). They were usually broken, but evidently the pieces represent a great many varieties. Upright female figures in various attitudes are represented (No. 403) but there are specimens of a type representing the seated goddess Cybele, like No. 446. The head is crowned by a high head-dress (No. 541).

Minor objects (Pl. CLXXVI, 4—7).

The minor objects are very few. Some of them have no connexion with the temples, being mere stray finds in the filling. Such are the amber bead (No. 473), the finger-ring (No. 492), the arrow-head (No. 475), and the handle to a bronze vase (No. 345).

I r o n.

The loop (No. 450) might be connected with the door of Room V and have had some purpose for closing this.

B r o n z e

No. 325 is a fragment of a bracelet of the same kind as is seen on the upper arms of No. 439. This kind of bracelet seems to belong to the cult-dress. Other fragments of bronze are found under Nos. 326 a—b. It cannot be determined from what object they originate. No. 344 constitutes a common type of bronze leaves.

L e a d.

No. 471 b is a weight inside a vase (No. 471 a).

Coins (Pl. CLXXVI, 9—CLXXVII).

The coins are equally spread over a comparatively long period, the earliest dating from the period of Ptolemy Soter; the last from the reign of Licinius, 327—333 A. D. Outside this series there are two coins of much later date, one from the reign of Valentinianus II, 383—392 A. D., and one from the Byzantine emperor Heraclius, 610—641 A. D.

The Ptolemaic coins are seven in number. No. 421 dates from the time of Ptolemy Soter and is of the same type as Svoronos, No. 277, p. 47; Pl. X, 7.¹ From the reign of Philadelphus

there is only one coin (No. 549). This, according to Svoronos, is ascribed to the period before the year 272 B.C.² Two other coins are dated to the third century (Nos. 487, 548). They are both of the same type and belong to the Cypriote coinage of Arsinoe III, of the years after 212 B.C.³ No. 486 is also of a Cypriote coinage but dates from the reign of Ptolemy Euergetes II. Such coins were struck in Cyprus in the years 144—129 B.C.⁴ Slightly later is the coin, No. 543, from the reign of Ptolemy Soter II. Nearly all the bronze coins of this type are of Cypriote origin, and, therefore, as Svoronos has pointed out, the whole bronze coinage may be Cypriote.⁵ The coin is similar to Svoronos Pl. LVIII, 23, and he may be right in his suggestion that the type was struck in the year 95 B.C. The latest Ptolemaic coin dates from the period of Ptolemy Auletes (No. 488): it belongs to a rather small class of coins which are probably of Cypriote origin.⁶ They most likely belong to the daughter of Auletes and can be dated to the later part of the reign of Auletes, 55—51 B.C.

The earliest coins of the Cypro-Roman coinage are not represented among the finds. The well known types of the Cypriote coinage of Trajan are represented by three coins (Nos. 333, 442, 444). The Paphian temple is represented in a way usual on earlier coins from Augustus to Trajan.⁷ No. 444 is illegible but may have been of the same type. From the second century there is only one other coin (No. 479), of the period of Faustina I (138—141 A. D.).⁸

From the time of Septimius Severus onwards, the series of Roman coins is not so fragmentary. Three specimens from the time of Severus and his family were found, and after this, the third century is represented by a series of coins up to the reign of Aurelianus. The Septimius Severus coin (No. 440) is the only silver one of the collection.⁹ No. 456 is of Cypriote type and bears the head of Julia Domna.¹⁰ It shows a very clear picture of the temple on the reverse. A similar type of temple is seen on No. 445, from the time of Caracalla.¹¹ No. 422 dates from the reign of Gordianus Pius.¹² No. 308 is worth notice. These coins have previously been ascribed to the Antioch mint (*Brit. Mus. Cat., Galatia, Cappadocia and Syria*, p. 205, Nos. 447—450). Dr. Clemens Bosch, however, has in a letter kindly informed me that the mint probably is Cypriote. According to Dr. Bosch, No. 308 should be ascribed to Severus Alexander. The letters *AE* on the *reverse* are abbreviations for *ἀνατολίτικῆς ἐξουσίας*. The coins of this type of Elagabal and Severus Alexander are difficult to distinguish from each other. The few readable letters on the *obverse* seem to confirm the attribution of the coin to Severus Alexander. No. 423 is similar to Cohen, IV, p. 497, No. 78, and dates from the time of Julia Mamaea. Of a somewhat later date is coin, No. 420, of the following period, of Maximinus.¹³ It may be assigned to the year after the end of the German war (236 A. D.). No. 490 may be compared with the Aurelianus coin of the Antioch series¹⁴ though the inscription *OP. BIS* is known only from the Tripolis series.¹⁵

The Constantine coinage is comparatively well represented and the series is opened by No. 451, of Maximianus' time.¹⁶ The Constantine coins proper are five in number. Two of them are of the Roman mint; No. 482 of the sixth series.¹⁷ No. 491 of the seventh series.¹⁸ No. 346 is similar, but too worn to be assigned to any of the series. No. 480 is of the

Constantinople mint, third series¹⁹, and No. 454 of the Aquileian mint²⁰; the worn state of preservation of the coin makes it impossible to state with certainty to which series it belongs.

The Lininius coins are five in number, from different mints. No. 330 belongs to the fourth series of the Aquileian mint²¹ which is dated to 313—314 A. D. No. 424 is of the ninth series of the Antioch mint dated to 327—333 A. D.²² No. 449 is of the eighth series of the Cyzicus mint and can be dated to 324—327 A. D.²³ while No. 484 is of Nicomedian origin, eighth series which is dated to 318—324 A. D.²⁴ No. 347 is of the Cyzicus mint and dates from the year 314 A. D.²⁵ All these coins of the Constantine era seem to form a good dating of the end of the period during which the temple site was used. As a matter of fact only two coins of much later epochs were found (Nos. 332, 483), but they are certainly to be counted with as mere stray finds; one belongs to the period of Valentinianus II (383—392 A. D.)²⁶ and the other to Heraclius (610—641 A. D.)²⁷

Lamps (Pls. CLXXIV, 4—CLXXV).

Type 1.

(Nos. 404, 545, 546, 555, 557). Open lamps, sometimes with raised base; curved sides; rim pinched to a nozzle.

Type 2.

(No. 349). Lamp of coarse clay; nearly biconical sides; narrow, central hole with plain rim; short, conical nozzle.

Type 3.

(Nos. 569, 575). Lamps on raised base-ring, biconical sides; central hole with moulded edge, thick nozzle; pierced knob on left side. (The type corresponds to Broneer's Type X,²⁸ dated to late 3rd Cent. — Beginning of 2nd Cent. B. C.)

Type 4.

(No. 554). Flat base; raised sides; deep, moulded discus; volutes on nozzle. (Corresponding to Broneer's Type XXII, period of Augustus continued through 1st Cent. A. D.)

Type 5.

(Nos. 351, 353, 357, 359, 361, 370, 371, 373, 375, 381, 387, 400, 401, 496, 516, 551). Shallow lamps with moulded discus, as a rule with representations; comparatively long nozzle with volute decoration in relief on upper side; usually no handle. (Corresponding to Broneer's Types XXI—XXIV. First half of 1st Cent. A. D.)

Type 6.

(Nos. 352, 354, 355, 358, 360, 363, 364, 365, 367, 368, 369, 372, 374, 376, 378, 380, 382, 383, 384, 385, 386, 388, 389, 390, 392, 393, 394, 396, 398, 459, 514, 515, 552, 556, 576).

Circular lamps with concave discus within a flat wide rim, often with an ovule pattern; short, triangular nozzle; with or without handle. Some of the lamps are provided with small knobs on either side of the rim (Nos. 365, 383, 386, 390. This type corresponds to Broneer's Types XXIV—XXV and to Loeschcke's²⁹ Type VIII. They are dated to the middle of the 1st Cent. A. D. and the type continued to the end of the century).

Type 7.

(Nos. 525, 526, 527, 528, 529, 529 a). Moulded lamps of somewhat larger size, circular in shape; very thin walls; wide, somewhat sloping rim; concave discus with impressed designs; the nozzle is partly placed on the rim; triangular in shape; moulded handle with incised lines. The type corresponds closely to Broneer's Type XXVII dated by him to the 2nd Cent. A. D.

Type 8.

(Nos. 327, 356, 362, 366, 377, 379, 391, 395, 399, 467, 577). These lamps are ascribed to one type in accordance with Broneer's Type XXVIII, though certain variations within the type are recognizable. As a rule, the lamps are more or less oval in shape. Nos. 327, 467, 577 have a very short nozzle placed partly on the rim; the rest have prolonged nozzles with volute decoration in relief. The discus is usually small especially on No. 379 where all the decoration is concentrated to the bulging rim.

Type 9.

This type is represented by the large lamp No. 494 with the deep relief decoration on the discus. Chronologically the type may be placed after the preceding types.

Loom-weights (Pl. CLXXVI, 1—3).

The loom-weights are of mainly two types: 1. Circular, disc-shaped; pierced either at centre (Nos. 559, 560, 566, 567, 568, 571, 573, 581, 585), or near the centre (Nos. 558, 561, 562, 580, 582). Sometimes the shape is somewhat rhomboid (Nos. 550, 572, 579, 583, 584). 2. The second type of loom-weights are truncated pyramids, pierced at the upper end (Nos. 563, 564, 565).

Glass (Pl. CLXXVI, 8).

The glass bottles (Nos. 397, 430—436) are all of a similar type with long tubular neck.

Inscriptions (Pls. CLXXIII, 15, 16—CLXXIV, 1—3)

For the inscriptions reference is given to Appendix III.

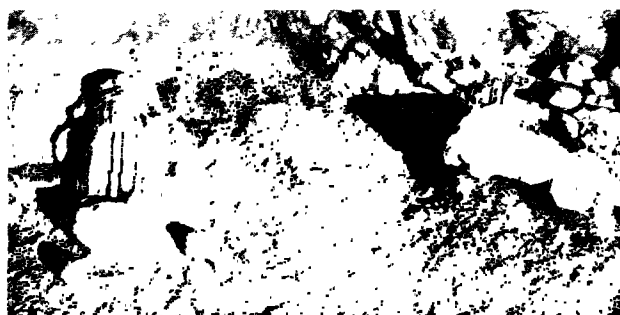
Fig. 281. Soli. Room V, finds *in situ*.Fig. 282. Soli. Room V, finds *in situ*.

CONDITIONS OF FINDS

Apart from the pottery fragments, which are more or less significant for practically every ancient site and which here will be used as dating material in the ordinary way, the finds were made under very differing conditions. In many cases, these conditions must be taken into consideration separately if a proper understanding is to be obtained of the date of the objects and of the way they may be used for the dating of the monuments. In general, the objects and the sculptures were found roughly in three ways: 1. Mere stray finds lying accidentally in the various strata without definite connexion with these, or with the architectural monuments. These finds can only be used like the pottery fragments, in the question of the chronology. Besides the pottery, the coins and other small objects should be, as a rule, referred to this group. The coins in reality constitute the most valuable objects for the absolute dating of the monuments. 2. Objects, especially sculpture, which evidently were re-used for a secondary purpose. The cases of such conditions were numerous and proved to be most valuable for dating. It is but natural, of course, that a fragment of a statue found as a building-stone in a wall (Fig. 287) must belong to a sculpture which was made considerably earlier than the wall was built, as it must be supposed at least in most cases that the sculpture was taken from some other temple which for some reason had ceased to be used, or from which the old sculptures were removed. This seems frequently to have happened in ancient temple-sites. 3. The third group of finds consists of those which were discovered more or less *in situ*. Only occasionally their exact, original position could be ascertained, but careful examination of the stratification usually gave evidence enough for a reasonable suggestion as to their origin. The sculptures, found more or less *in situ* were always located to the temple *cellae* or their close vicinity, or the layer in which they were discovered, could in some way be connected with a *cella*. It may be put forward here that the sculptures probably were placed on the altars in the *cellae*. The altars, therefore, must have been in the nature of an *ikonostasis*, or a stand for the various sculptures. This explains their great size. This suggestion holds good only as to the altars *in the cellae*. In no case was a similar arrangement observed as regards the altars out-of-doors, in the courtyards. Here, no sculptures were found under conditions indicating that they were originally placed on such altars.



Fig. 283. Soli. Stair 159 with finds *in situ*.



Fig. 284. Soli. Altar 156 with finds *in situ*.

In the *cella*, Room V, some sculpture fragments were found in a layer on the floor. There is no reason for not ascribing these sculptures to the same *cella*. As all of them were found east of the altar, just in front of the entrance (Figs. 281 and 282; Plan XXXVIII), it is natural that they could have been placed on the altar which, when it was destroyed, fell in this direction (cf. Section II). The layer which contained the sculptures extended outside the *cella* part, as far as to Stair 159. To judge from these conditions it may be right to ascribe all the sculptures of this layer to the same *cella*, Room V, though the possibility must be noted that those found below Stair 159 (Fig. 283) can have come from Altar 146. Are the finds of Room V to be ascribed to Temple B or is it possible that some of them have remained from the first temple, A? This question is extremely difficult to settle definitely. It may, however, be pointed out that there are no signs of a destruction of the *cella*. The altar 147 must for constructional reasons be ascribed to the temple B but there may have been another altar at the rear of the *cella* in the first period. The floor is here slightly raised. On the other hand most of the marble sculptures had been already broken and mended in ancient times. Whether this happened in the factory as a consequence of the artist's bad technique or small acquaintance with marble as material, remains uncertain. It may, however, also be explained so that the sculptures, broken during the first period (Temple A) were mended for the second period (Temple B). In any case the great number of cases in which the marble sculptures have been mended, indicate that this material was considered so unusual and so valuable that they had to be preserved from one generation to another, even if they were broken in many pieces.

In Temple C, only a few sculptures were found in close connexion with the *cella*. In the *cella* proper, a coin (No. 480) only, of the Constantine period was found, but in the portico, Room XVII, some sculpture fragments were noted, which may have originated in the *cella*.

SOLI

The temples at Cholades

Finds *in situ*,
Room V.

PLAN XXXVIII

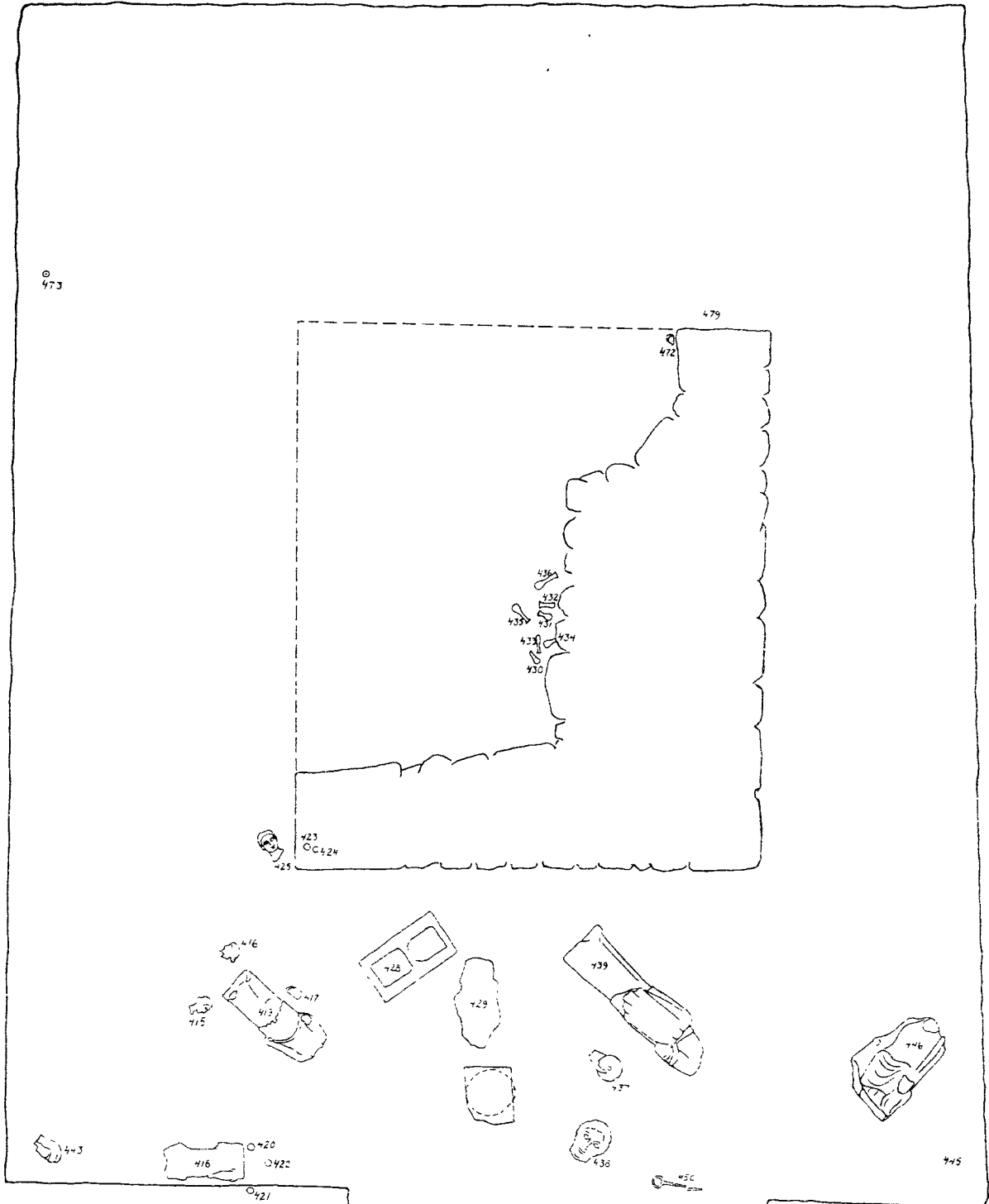

The temples at Cholades

Deposit of lamps
in Room XXV

1:10

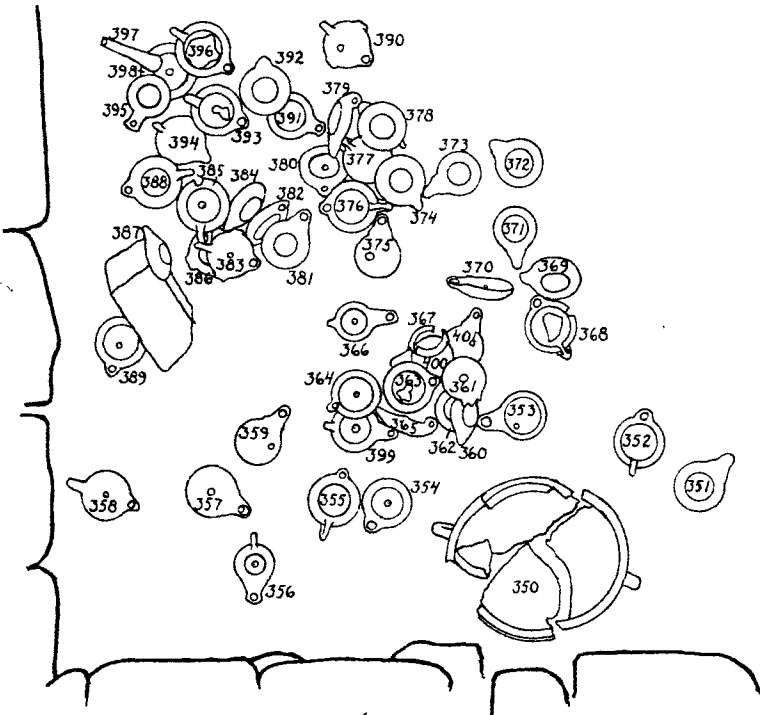

1

Finds in Room
XXXIV

1:25

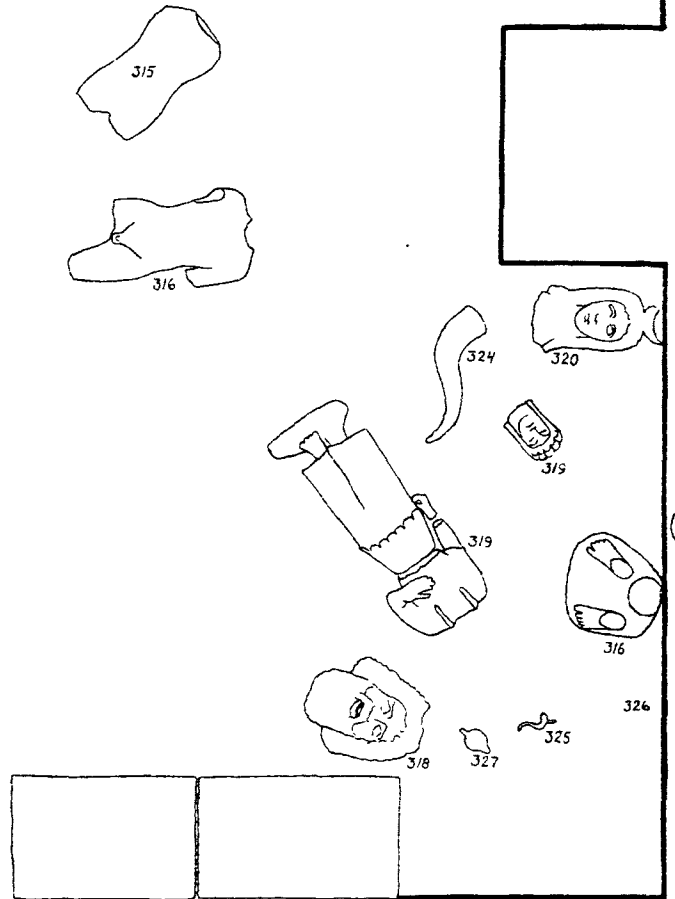

2

Finds below
Room LIV

1:25

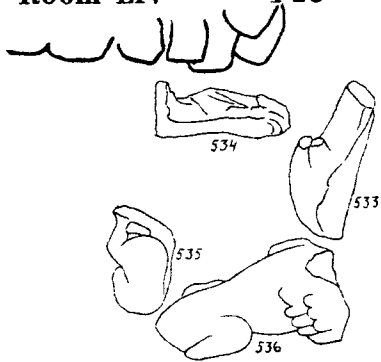

3

Finds on Altar
156

1:40

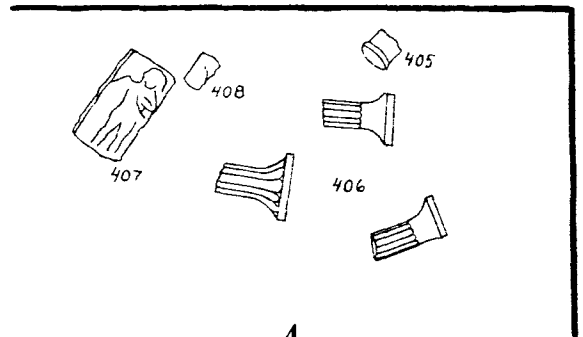

4

Mural painting
on Wall 23

1:30

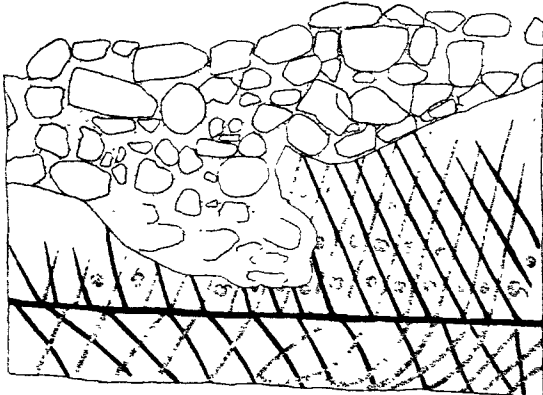

Black. Red

A-A

5

Façade of Altar
155

1:30

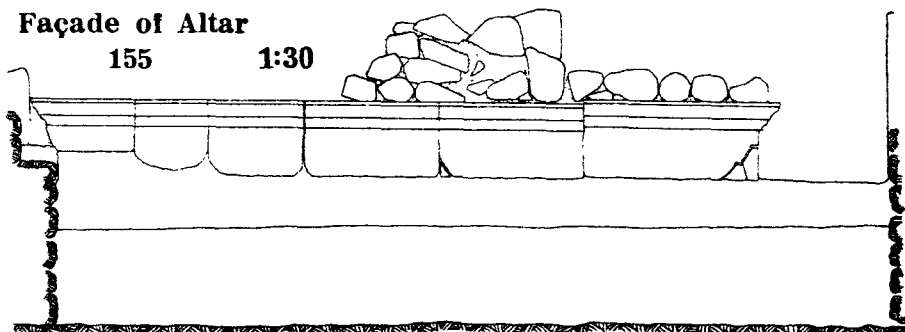

B-B

6

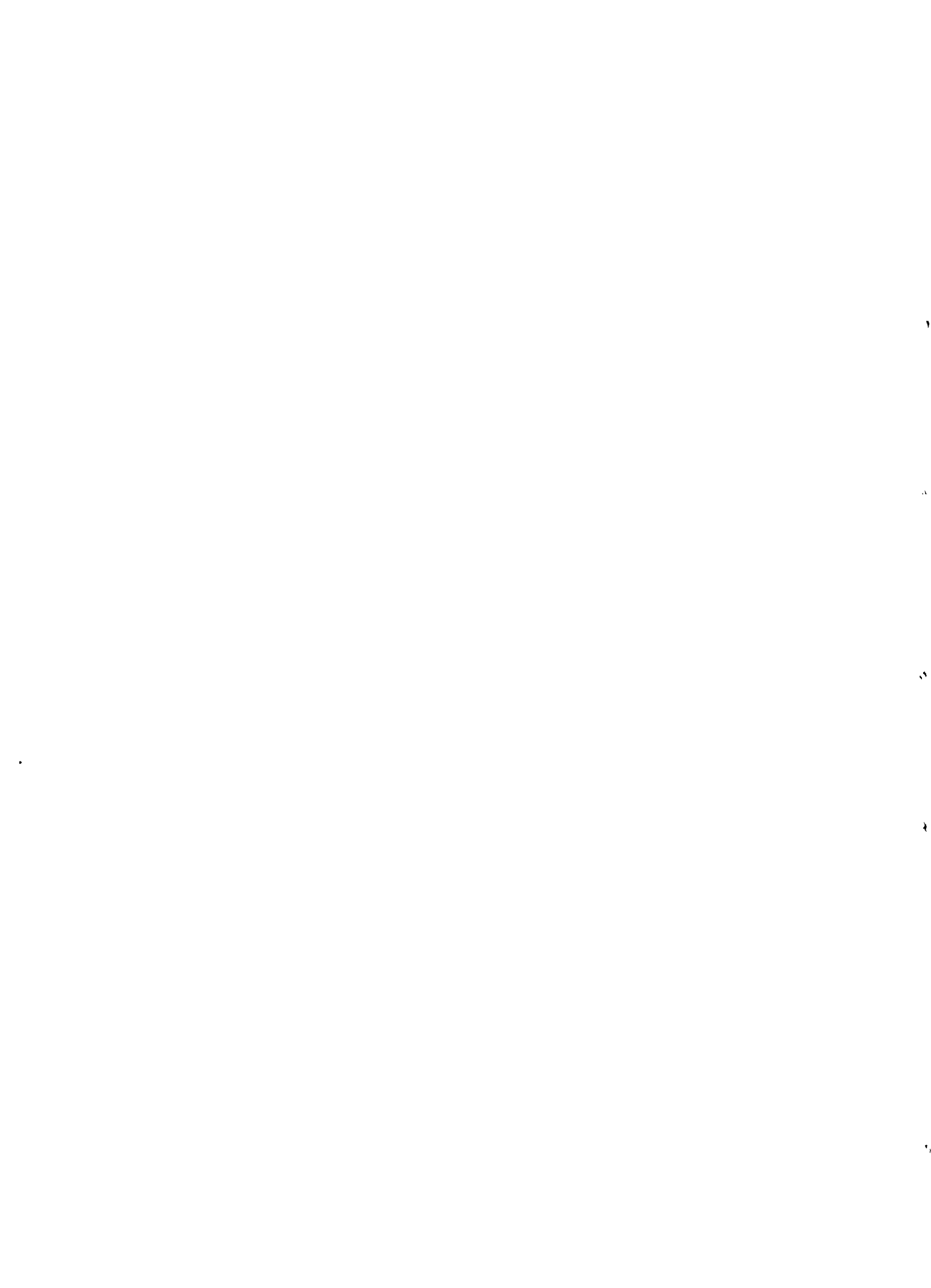

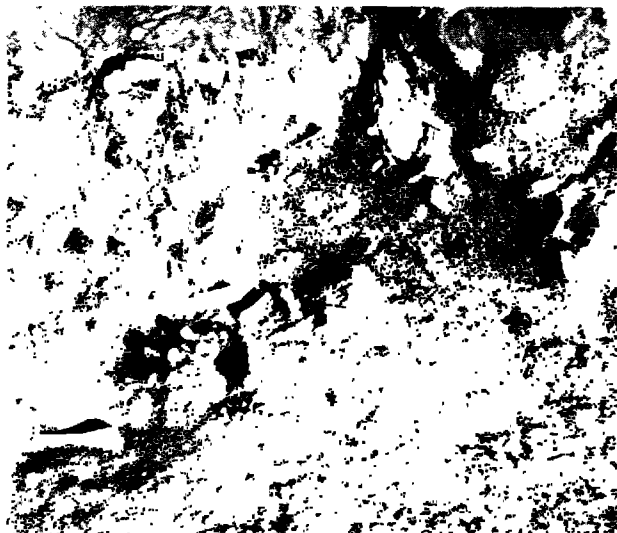

Fig. 285. Soli. Glass bottles (Nos. 430—436) *in situ*, below Altar 197.



Fig. 286. Soli. Lamps *in situ* in Room XXV.

The large Agrippina head was found just outside the entrance of the *cella*, and further to the south, the satyr head (No. 469) and the small mourning Isis (No. 427).

All the three *cellae* of Temple E contained sculptures which were more or less *in situ*. As three separate styles were distinguished among these sculptures, it may be asked what relation the sculptures have to the buildings on this locality. Two of the styles may be combined with the two building periods of Temple E, but there remains quite a large group of sculptures, which were found in Room XXXIV and are of the same style as those from Temple C. This latter must have been erected considerably earlier than the Temple E which makes the conditions rather complicated. In the *cella*, Room XLV, things seem to be easy to explain. Here all the finds of sculptures were lying on the altar, evidently not very much disturbed (Fig. 284; Plan XXXIX, 3). No doubt these originally were placed on the altar. The same is the case in Room XXXV where the Canopus sculpture (No. 329) was found practically *in situ* still upright on the altar. With the exception of some minor fragments and the head, No. 448, no other sculptures were found here. In the central *cella*, however, the sculptures were found lying without any order. One group was situated on the floor in the eastern corner of the room (Plan XXXIX, 1). Other sculptures were found among the fallen stones from the walls. On making an investigation of this matter, it became clear that all the sculptures of this room attributed to Style II were among the fallen stones and the sculptures of Styles III and IV were in all cases located on the floor. As many of the sculptures of Style II had mortar adhering to them it is evident, that they had not belonged to the Temple E, other than as building-stones taken from elsewhere. This was confirmed by the finding of one head (No. 328) of Style II A, still *in situ* in the wall.

Now the question arises: from which temple were these sculptures taken in order to be re-used as building-stones for the new construction of the *cella*? As sculptures of Style



Fig. 287. Soli. Statuette (No. 339) re-used as a building-stone in Wall 99.

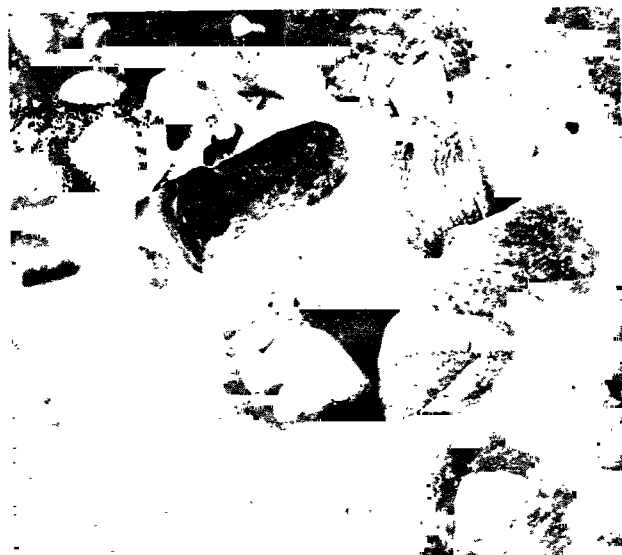

Fig. 288. Soli. Sculptures (Nos. 533—536) in the earth-filling below the floor of Room LIV.

II B were found in the Temple C the possibility must be taken into account that the sculptures were placed originally in this temple, especially as most of the fragments can be certified as belonging to statues representing the goddess Isis. A small Isis statue was found in the portico outside the *cella* of Temple C. Besides, there are reasons to believe that the Agrippina-head was represented as the goddess mentioned. On the other hand it must be noted that the fragments re-used as building-stones were concentrated chiefly at two points: the walls of the central *cella* and the walls around the entrance into the courtyard. If the pieces were brought from Temple C only, one should expect to find them spread out in some more of the new walls of Temple E. But this is not the case, and, besides, there are no signs that Temple C was destroyed and deprived of its sculptures. Is there some other temple then which might have supplied the new construction with this sculptural building-material? Temple D was situated just below Temple E, and if the conditions were similar here to what we know from the other temples the sculptures should have been placed in the two *cellae* of that temple. If the final destruction of this was caused by an earthquake or some other violent event, it is natural to suppose that the sculptures were buried under the debris of the walls. Certainly the same fallen stones on the place were used when the new Temple E was constructed partly on the old foundations, and among them the fragments of the sculptures may have come into the walls. The sculptures found in the walls around the entrance, Stair 165, may be explained in the same way. Among them is the sphinx, No. 302, which was discovered by the land-owner before the work started. That sculptures really were once placed in connexion with the Stair 163 was confirmed by finding some fragments in the filling just below Wall 79. Apart from head No. 547, the lower part of a terracotta statuette was discovered, possibly standing *in situ* (Fig. 240).

No sculptures could be connected directly with Temple F. The small deposit found

below the floor of Room LIV should certainly be considered as mere filling (Fig. 288; Plan XXXIX, 2).

Other accidental finds of sculptures were made in the portico along Wall 20, but these were used as building-stones in it and were lying in this wall or among the fallen stones, sometimes with mortar adhering to them.

A sealed deposit of terracotta figurines, however, was discovered in the offering pit which is supposed to have been connected with an altar on the courtyard, Room II. If this presumption is right they must be ascribed to the first temple, A.

Two sealed deposits of lamps were found, one in Room XXV which seemed to have come with rain-water in the passage between the chapel, Room XXIII, and Temple E. Evidently these lamps had been gathered against a piece of wall in Period 4. To the same period another deposit of lamps must be referred, found in Room XXVIII.

Something must be said as to the inscriptions, Nos. 322 and 323, found in Room XXXIV; they should probably be connected with Temple E. No. 409 was found among fallen stones in Room XXVII and may have been re-used as a building-stone in Temple F or have been fixed on Wall 22. If the temple of Priapus, mentioned on the inscription, refers to any of the temples or minor chapels excavated remains uncertain. Nos. 428, 453, 456 were all found under conditions which make it certain that they should be connected with the temple *cella*, Room V. Possibly the pieces, No. 493, unfortunately scattered all over the courtyard, Room III, and the gate, Room VII, originated in the *cella*. As to No. 512 it may be pointed out that it had been evidently re-used in some way, probably as a base for a column. It was found among the fallen stones outside the *cella*, Room V.

The pottery was collected in accordance with the stratification described above. Usually it was possible to determine to which temple, or to which architectural period the pottery of the various strata should be attributed.

RELATIVE CHRONOLOGY

As regards the architecture, the relative chronology and the chronological sequence of the various constructions has been established above. Temple A must be the first building followed by Temples B, C, and D after an intermediate period of which we have but scanty architectural remains. Whether Temples B and C were constructed contemporarily with Temple D, or if the latter was built somewhat earlier or later, remains uncertain. They are, however, all assigned to the same main Period 2. After the destruction of Temple D, follows the second intermediate period which makes the supposition necessary of a comparatively long time between the beginning of Period 2 and the beginning of Period 3. The latter is marked by the construction of Temple E which was altered and provided with some additions in a following Period 4. This sequence of constructions cannot be disputed on account of the evidence given above, and we will now proceed to the various finds and see in what way their classification corresponds to the periods.

As regards the sculptures, the various styles can be attributed to certain temples and cer-

tain periods. In a few cases it proved to be impossible to do so, but in such cases it could sometimes be ascertained that the sculptures in question could not be later than a certain building. In other cases, sculptures could be ascribed to certain temples with more or less certainty on grounds, other than their position in the earth.

Among the sculptures of marble two styles are recognized, and, apart from them, the portrait of Agrippina (No. 414). Though most of these sculptures were found in Temple B there is reason to believe that they should be ascribed to Temple A or, in any case to a period prior to the construction of Temple B. Many of the marble sculptures were broken and mended in ancient times. This indicates that the rare material was considered too valuable to be thrown away even if the sculptures broke. But the main argument for the attribution of the marble sculpture to the period of Temple A is a stylistic one. Even if the dating of the marble sculpture is based entirely upon the Soli material, and all comparisons with foreign Hellenistic sculpture are disregarded, they must be ascribed to a period prior to Temple B, because Styles I A and B of the marbles must for stylistical reasons be contemporary with the corresponding styles of the sculpture in hard limestone. As it can be proved that several of the latter had been re-used as building-stones in walls which actually belonged to Temple B, it follows, that the styles mentioned cannot be connected with the sculptures placed in that temple. Sculptures belonging to Styles I A and B must be of earlier date than the construction of Temple B. For similar reasons the same holds good of the sculpture in soft limestone.

The sculptures which originally were made for Temples B—C—D were those of Style II A and B. It may be mere chance that none of them were found in Temple B and only a few of them in Temple C. This might be due to the fact that these temples were used during a very long period, a fact demonstrated by the series of coins from the floors. The architectural analysis, however, has shown that the temples in question must have been built almost contemporarily, and there can be no doubt as to which style should be connected with that building period. Not a single piece of Style III can be connected with these early temples. Chronologically, Style III falls after the second intermediate period and is significant for Temple E. They were all found more or less *in situ* in the *cellae* of that temple and should, certainly, therefore correspond to the architectural period of Temple E. The sculptures of Style IV were found mixed with those of Style III and can be distinguished only on stylistic grounds. For stylistic reasons Style IV constitutes the last sculptures of the whole series. This indicates that Style IV should be connected with the building period 4 characterized by the alterations in Temples B and E, and the construction of Temple F.

The way in which the sculpture styles were connected with the various temples and periods is demonstrated in the following diagram:

	Temple A	Temples B	C	D	Temple E	Temple F	Periods beginning about (cf. below):
Period 1	■						250 B. C.
1st Intermediate Period							End of 2nd Cent. B. C.
Period 2		■					After 50 B. C.
2nd Intermediate Period							End of 1st Cent. A. D.
Period 3					■		Middle of 3rd Cent. A. D.
Period 4					■	? ■ ?	Beginning of 4th Cent. A. D.
	Styles I A—B	Styles II A—B			Style III	Style IV	

We proceed to the lamps and find that a similar distribution of the various types between the temples can be noted. Types 1—4 are almost equally distributed between Temples A—B, while these types are represented in Temple D by one specimen (No. 349 of Type 2). The deposit of lamps in Room XXV did not contain specimens of Types 1—4. The bulk of the deposit consists of Type 6, though, Types 5, and 8 are frequent, too. Type 7 is represented by another deposit which must belong to Period 4, as it was situated just outside the wall of Temple F.

The numbered, complete vases can in no way be significant for the distribution of the pottery found at the site.

The pottery sherds were collected exclusively with the consideration to the layer in which they were found, and each layer or locality was strictly separated. In the following diagram the plain and coarse wares are omitted as they were represented in all layers, and, as a rule, constituted at least 80% of the whole quantity. The diagram is arranged in accordance with the following principles: the localities are placed in the chronological order which is given by the analysis of the architecture described above. Within each period the various temples are separated. Furthermore, for every unit of collection, reference is given to a section written in Roman figures, and the layer on this section, written in Arabic figures. In cases when the localities not can be referred to any section, the room in which the sherds were found is indicated.

Period	1 1st int.			2			2nd interm.			3		4																													
Temple	A			B			C			D			E		F																										
Room or Section	Sect. III,7	Sect. III,19	Room XIIII	Sect. III,12	Sect. III,18	Sect. III,16	Room XIII	Room XI	Room II	Sect. III,6	Sect. III,4	Sect. III,5	Room XI,II	Room XI,I	Room XXX	Sect. XV,7	Sect. XI,5	Sect. VI,5	Room XXVI	Sect. V,5	Sect. VIII,6	Sect. X,4	Sect. X,5	Sect. XIV,7	Room XXIX	Room XVI	Sect. X,7	Wall 106	Sect. V,4	Sect. XVI,8	Sect. XVII,11	Sect. XVI,6-7	Sect. XVII,4	Sect. XVI,4	Sect. XVII,9	Sect. XVI,5					
Bl. L. I	4	1				5 2	2 1	2	3 1	1 1	2																														
Bl. L. II	8	2 11				5	38 8	2 2 5	7 23 12	6 7 3	8 3	1 2																													
M. Bl.		2 8	1 4	4 23	62 28				1	5	3	5 2 10	3 7 5 2																												
R. L. I	8	2 16				2 2	2 6 4		2 5 6 3 7 1	1 1 6																															
R. L. II			6 3	13 2 46	25		6 8 3	22 32		10 13 8 8 5		5 9 2																													
M. R.				12 8	35 20	1 50	1			4	2 7		5 5 3																												
Bl. Pol. I									1 2																																
Bl. Pol. II									1																																
Mon. Red.																																									
Grooved W.																																									
Wh Sl. Gr.																																									

This diagram shows that there is hardly possible to make any distinctions as to the quantity of the Black Lustrous I—II and the Red Lustrous I—II Wares during Period 2. These wares are represented in this period and it is clearly noted that the Black Lustrous II and Red Lustrous II are predominant in comparison with the Black Lustrous I and Red Lustrous I Wares. In the 1st period no Red Lustrous sherds were found, whereas these begin in the 1st intermediate period, represented by Red Lustrous I Ware. The mat wares, black or red, are not found in the 1st period. In the 1st intermediate period only Mat Black Ware is represented while the Mat Red Ware appears in Period 2. From this period onwards the mat wares dominate, and, evidently they do not terminate contemporarily with the Black- and Red Lustrous Wares but occur also frequently in Periods 3 and 4. Characteristic of these periods are also the Monochrome Red, the Grooved, and the White Slip Grooved Wares, which not are met with prior to Period 3. The Black Polished Wares are represented in Period 2 and the 2nd intermediate period. As far as the stratification shows, there can thus be distinguished two epochs of interruption, 1. between Period 1 and the 1st intermediate period; 2. between the 2nd intermediate period, and Period 3, a result which on the following pages will be confirmed by the evidence given by the coins.

ABSOLUTE CHRONOLOGY

For the absolute chronology the coins constitute the fixed points. It is necessary, however, to be chary in using the coins as dating objects. For every coin which is used, one should know the condition under which it was found, and every case must be judged by itself.

When a coin is found on a floor it usually indicates that this floor was used contemporarily with the coin, but nothing is therefore ascertained concerning the time when the floor was laid out. If we find a long series of coins, dating from various periods, lying on one and the same floor, this might indicate, as a rule, that the floor was used during a corresponding period. It is but natural that the later part of such a period is better represented by coins than the first part. Coins, lying in the filling below a floor must always constitute a *terminus post quem* for the floor, and the same is the case when a coin is found below a wall. Coins found in the upper filling have usually no significance for the dating of the architecture.

In order to facilitate making a survey of the coins and their attribution to the various temples, they are arranged in the following list. Here only such coins are considered which can be used as chronological evidence. Indecipherable coins are omitted, as are those found in layers or localities without any architectural significance. When it is stated below that a coin was found in a temple it means that it was found on the floor of any of the rooms of this temple. Below a temple means, on the other hand, that it was found below any of the floors of this temple. Here follows the list mentioned:

312—284 B. C. Ptolemy Soter	No. 421 Below Temple A.
284—272 B. C. Ptolemy Philadelphus	No. 549 Below Temple D.
212—204 B. C. Arsinoe III	No. 548 Below Temple D.
212—204 B. C. Arsinoe III	No. 487 Below Temple B.
144—129 B. C. Ptolemy Euergetes II	No. 486 Below Temple B.
103—76 B. C. Alexander Jannaeus	No. 307 Below Temple C.
—95 B. C. Ptolemy Soter II	No. 543 In wall of 1st interm. period.
55—51 B. C. Ptolemy Auletes	No. 488 Constr. of Temple B.
112—117 A. D. Trajan	No. 333 In Temple B.
Trajan	No. 442 In Temple B.
138—141 A. D. Faustina I	No. 479 In Temple B.
193—211 A. D. Septimius Severus	No. 440 In Temple B.
—217 A. D. Julia Domna	No. 456 In Temple B.
211—217 A. D. Caracalla	No. 445 In Temple B.
222—234 A. D. Severus Alexander	No. 308 Below Temple E
222—235 A. D. Julia Mamaea	No. 423 In Temple B.
236—238 A. D. Maximinus	No. 420 In Temple B.
238—243 A. D. Gordianus Pius	No. 422 In Temple B.
313—317 A. D. Constantine	No. 482 In Temple B.
317—320 A. D. Constantine	No. 491 In Temple B.
Constantine	No. 346 In Temple E.
330—333 A. D. Constantine	No. 480 In Temple C.
330—333 A. D. Constantine	No. 489 In Temple B.
313—314 A. D. Licinius	No. 330 In Temple B.

318—324 A. D. Licinius	No. 484 In Temple B.
327—333 A. D. Licinius	No. 424 In Temple B.
324—327 A. D. Licinius	No. 449 In Temple E.
383—392 A. D. Valentinianus II	No. 483 In Temple B, upper layers.
610—641 A. D. Heraclius	No. 332 Surface find.

The list shows that some of the coins constitute a *terminus post quem* for some of the temples while the bulk of the material indicates the period during which the various temples were used. The coin, No. 421, dating from the reign of Ptolemy Soter I (312—284 B. C.) was found below Wall 7 and thus antedates the construction of the *cella*, Room V of Temple A. The second building period is also determined by means of a *terminus post quem*: Nos. 487 dating from the time of Arsinoe III (212—204 B. C.) and 486 from the reign of Ptolemy Euergetes II (144—129 B. C.) were found in layers outside Wall 20 into which the wall mentioned was sunk down. The layer must be of earlier date than the temple wall. On the other hand, the coin No. 488, dating from the time of Ptolemy Auletes (55—51 B. C.) was found on a floor layer just on top of the previous layer mentioned. This floor, or mere level, constituted the surface of the ground at the time when Temple B was constructed and the coin mentioned may thus give the approximate date of the construction of Temple B. We may place this event shortly after the middle of the 1st Cent. B. C. This was confirmed by the finding of another coin (No. 307) in the filling below the courtyard, Room XVI, belonging to Temple C which, as has been demonstrated previously, was constructed contemporarily with Temple B. This coin, dating from the reign of the Maccabean king Alexander Jannaeus (103—76 B. C.), was found on the floor-level (118.5) on which Wall 52 was founded. It therefore antedates the construction of Temple C. The dating of this important building epoch thus is well ascertained as the evidence from two different localities give about the same result. The construction of Temples B and C is, therefore, according to the coin evidence, dated to the middle of the 1st Cent. B. C. or shortly later.

It has been pointed out previously that the construction of Temple D for architectural reasons should be ascribed to about the same epoch. This is confirmed by the coins. There are two coins, which both antedate the 2nd intermediate period and, as far as could be seen Temple D, too. The coins were found below the filling of the floor in Room XXXVIII, which belongs to the 2nd intermediate period. No. 549 dates from the first part of the reign of Ptolemy Philadelphus (284—272 B. C.) and No. 548 from the time of Arsinoe III (212—204 B. C.). The temple might, of course, have been constructed much later than this latter date indicates, but the absence of dateable evidence does not allow a closer determination. The 1st intermediate period seems also to be determined by means of the coin No. 543, dating from the time of Ptolemy Soter II (95 B. C.). This coin was found in Wall 60 which may belong to the building system of the 1st intermediate period.

The coin No. 308, dating from Severus Alexander, constitutes a good *terminus post quem* for Temple E. It was found below the floor of Room XXXIV and therefore must belong to a period prior to the construction of the temple.

The absence of earlier coins in Temple E is striking. As a matter of fact there is none before the Constantine epoch but from this, three coins are preserved. Though one ought to be chary in using a negative evidence like this, it may be taken as a proof that Temple E was constructed not long before the Constantine era, which, however, as far as the coins show, constitutes the termination of the era during which the whole block of temples were used. As two periods are recognized as regards Temple E, one might suppose that this temple was constructed in the middle of the 3rd Cent. A. D.

The contrast between the series of coins in Temple E and Temple B is evident. While in the former only Constantine coins are represented, the series of coins from Temple B is spread out over a very long period, from the time of Trajan to the end of the Constantine period. With exception of the later part of the 3rd Cent., almost the whole period is represented by coins, most of which were found on the floor in the *cella*, Room V. These conditions show clearly that offerings were brought to this temple during the whole of this long period. The beginning of the period might fall earlier than this series shows, probably, as has been suggested above, as early as in the middle of the 1st Cent. B. C.

Curiously enough only one coin was found in Temple C, a Constantine coin, dating from 330—333 A. D. This shows that the temple, which for architectural reasons must have been constructed contemporarily with Temple B, was used as late as in the Constantine period.

In summing up the results of this investigation, we find that Temple A was probably constructed during the reign of Ptolemy Philadelphus or slightly later. The courtyard of this temple was destroyed, and altered later than in 95 B. C., or shortly after the reign of Ptolemy Auletes in the middle of the 1st Cent. B. C., i. e. the Roman occupation of the island. On this occasion, Temples B and C were constructed. Possibly on the same occasion, too, Temple D was built, as it must be of later date than the year 95 B. C. and, on the other hand, Water-conduit 167, constructed for Temple B, was laid out with consideration to the already existing or, at any rate, planned Temple D. The final destruction of this temple is unfortunately impossible to fix chronologically. The end of the 1st Cent. A. D. may be suggested as a probable date. The second intermediate period follows, the date of which is not determined; and, finally Temple E is constructed most probably in the middle of the 3rd Century at any rate not earlier than the period of Severus Alexander, and subsequently altered in the Constantine period when also Temples B and C were used, and partly altered. The date when the whole of this sacred site was abandoned is clearly fixed by the coins at the end of the Constantine era. The coin No. 483 from the time of Valentinianus II shows that the site was partly covered with debris at the end of the 4th Cent.

IDENTIFICATION OF THE TEMPLES

The determination of the nature of the temples can be ascertained by means of inscriptions and sculptures found in the temples, or in such connexion that they can be ascribed to any of them. For all the questions connected with the history of religion of the place, the reader is referred to the following volume of this work where a thorough study of that

chapter will be made. Here, only a very brief summary is given of the reasons for attributing the temples to certain gods.

As to the nature of Temple A, there is nothing which indicates with certainty to whom this temple was dedicated. If the suggestion is correct, that the marble sculptures of Styles I A and B belonged to that temple, it should be considered as a temple of Aphrodite. Because most of the sculptures are fragments of statues representing that goddess. As belonging to Aphrodites, Nos. 447, 438, 416 ÷ 463, and 466 can be determined while Nos. 417, 437, and 464 evidently constitute pieces of the same statue of a winged, mourning Eros, holding his torch turned down. He might well have been placed in a temple of Aphrodite. Apart from the marble sculptures there are two representations of Cybele (No. 446 in soft limestone, and No. 418 in hard limestone of Style I B). In reality everything indicates that the same goddess was worshipped in both Temples A and B, and, as has been suggested above, her statues even preserved from the one temple to the other in spite of the long time which has elapsed between the two. The real nature of this goddess is expressed by her name on the inscription No. 465 on which she is called Ἀφροδίτη Ὀρεΐα. Evidently this is a fusion between the Anatolian goddess Cybele who usually was called Μητέρα Ὀρεΐα. In Soli she was identified with Aphrodite by the Cypriotes, who called her Ἀφροδίτη Ὀρεΐα. This is the first time we meet with this name, though Cybele is often identified with Aphrodite. The characters of the inscription mentioned indicate a comparatively late period. The inscription thus must be ascribed to Temple B.

Temple C can also fairly well be determined. Here, however, no inscription has been found which could settle the question definitely. We have to rely upon the sculptures entirely. It has previously been pointed out that the head of Agrippina (No. 414) which was found in immediate connexion with the *cella* of that temple had a fracture on the crown, indicating that some head-dress must have been broken off. It seems natural to suppose that this has been of the kind, characteristic of the Isis heads. Fortunately, however, we are not entirely dependent on this rather vague argument for identifying the temple. The statuette of Isis (No. 427) kneeling on the drum of a column was found just outside the *cella* of Temple C and this find can hardly be explained otherwise than that the temple in which the statuette was placed was sacred to Isis. Besides, most of the sculptures of Style II to which No. 427 is ascribed proved to be fragments of statues of Isis. Though it cannot be ascertained definitely whether these fragments, most of which were found among the fallen stones from the walls of the central *cella* of Temple E, have been taken from Temple C or Temple D, it may be sufficient to state that at least one of them was sacred to the goddess Isis. As the sculptures of Style I can be connected with Aphrodite, those of Style II are connected with Isis. Possibly Isis was worshipped in both Temples C and D.

On account of the fairly good state of preservation of Temple E, matters are easier there. Evidently the syncretism is very much pronounced during this period. In the middle *cella* only, we meet with a great many deities. Though not wearing the usual typical *kalathos*, the large bearded head with the mourning expression (No. 318) is easily recognized as Serapis. The *kalathos* of another large head was found in one of the lateral *cellae* (No. 405).

But we continue the investigation in the middle *cella*. Nos. 334, 316, and 338 are most likely parts of a group which can be determined as representing the Dioscuroi. The *πίλος* of No. 334 makes this identification safe. Certainly the group was placed in the *cella*, possibly on the altar near the rear wall. The Dioscuroi may be connected with the dogs, the heads of which were found among the fragments of the floor (Nos. 312, 313). But it is perhaps more likely that the larger one of these heads should be interpreted as a wolf's head and that both of them constitute parts of a Cerberus especially in consideration of the fact, described above, that the heads were more carefully sculptured on one side than on the other. This allows the conclusion that the heads were placed on either side of some object or close together. If Cerberus is reconstructed with a head, like No. 509, the larger (wolf's) head must be placed to the right of the central lion's head and the smaller one to the left. If this is correct, we meet with a type of Cerberus which is characteristic of Alexandria. This type of Cerberus was represented in the Serapeum of Alexandria and coupled to Bryaxis famous statue of Serapis. According to Macrobius³⁰ this Cerberus had in the middle a lion's head with a wolf's head on the right and a dog's head on the left. The monster was encircled by a serpent. Wilcken found a Cerberus of this type in the entrance to the Serapeum at Memphis.³¹ Other specimens of the same type are found in British Museum,³² the Ny Carlsberg Glyptothek,³³ Turin Museum,³⁴ and finally in the Alexandria Museum.³⁵ The Serapis head (No. 318) and the pieces of a Cerberus, as they all have been found in the same room, may be the only preserved fragments of the same group, *viz.* Serapis with Cerberus as it was represented by Bryaxis in the Alexandrian Serapeum. The serpent (No. 335) might for iconographic reasons very well be connected with Serapis, the ruler of the shades and his monstrous guardians. For a further discussion of this, reference is given in the next volume of this work.

While the large, central *cella* of Temple E thus was sacred to Serapis, it is not surprising to find that in the northern lateral *cella* of the same temple another Chthonic deity was worshipped, i. e. Canopus. The cult-statue of Canopus (No. 329) was found but slightly removed from its original position on the altar of that *cella*³⁶. It may be sufficient in this connexion to state that the northern *cella* was reserved for Canopus, and we proceed with our investigation to the south lateral *cella* of the same temple. Here the relief, No. 407, representing the mourning Eros, was found on the altar, apparently fallen from its original, upright position against the rear wall above the altar. It might be correct to reconstruct the original arrangement here as follows: the relief in upright position in the middle of the wall, framed by the two marble half-columns (No. 406) on either side. Eros must be regarded as a Chthonic deity, as he holds the torch turned downwards.

Thus we find this temple crowded with deities all of whom should be connected with the Chthonic sphere of divinities. The central god is Serapis who occupied the central, large *cella*. The syncretism of late antiquity is very clearly expressed by these conditions and it is, therefore, not surprising that we have to add at least one other god to this series, represented by the sculptural finds. The inscription, No. 409, mentions a *Ἡρώαρον ἱερόν* which was built at the order of Serapis. Unfortunately it is impossible to locate or determ-

ine this temple of Priapus, as the inscription was found re-used as a building-stone fallen from a wall of Temple F. The temple of Priapus might have been situated elsewhere or be some of the undeterminate chapels connected with any of Temples B or E. Priapus might also have had a place in Temple D. The inscription is interesting also from the point of view that the god Serapis is mentioned.

For the identification of Temple F we must rely entirely upon the architecture, as neither inscriptions nor sculptures were found which could solve the problem. Nothing can be stated with certainty as to this question, but comparisons with the other architecture, will bring the building in close connexion with sanctuaries sacred to Mithras.

In the foregoing we have been able to state that Temple B and probably also Temple A was sacred to Aphrodite in connexion with Cybele (*Ἀφροδίτη, Ὀρεια*). For this, both inscriptions and sculptures give evidence enough. One or possibly both of Temples C and D were sacred to Isis. This is shown by the sculptures in the *cella* walls of Temple E, which was sacred to Serapis (middle *cella*), Canopus (northern *cella*), and mourning Eros (southern *cella*). The architectural features of Temple F makes it likely that this was sacred to Mithras though neither inscriptions nor sculptures were found confirming it. For the rest of the small chapels nothing but mere suggestions can be said as to their identification.

In the chapter on the chronology of the temples it has been argued that Temple A, built in the middle of the 3rd Cent. B. C. was replaced by the double-temple of Aphrodite and Isis about the middle of the 1st Cent. B. C. Furthermore, Temple E cannot, judging by the material, have been constructed much before the middle of the 3rd Cent. A. D. But the temple was still in use during the Constantine period. This holds good, too, as regards Temples B—C, and, finally, Temple F was most likely built during this epoch. The building activity therefore was concentrated at certain periods: with the exception of the first one in the 3rd Cent. B. C., at the middle of the 1st Cent. B. C. and at the 3rd Cent. A. D., and Constantine period.

Now we return to the ancient records of the topography of Soli in order to find out how they correspond to the excavation results obtained. Strabo who may have visited Cyprus just before the birth of Christ mentions the *ἱερὸν Ἀφροδίτης καὶ Ἰσιδος*, but he does not give any detailed particulars as to its place in the town. At the time of Strabo, Temples B and C, the great enlargement of the old Temple A, were just ready, and, as it is not likely that two double-temples of this kind existed at that time in Soli, there is reason to identify Temples B—C with those mentioned by him.

As to the topographical statements given in the *Acta Auxibii* (cf. above) matters are very different from the records of Strabo, as comparatively clear particulars are given of the *templum Jovis Dei — in quo flumen Dialis habitabat*. The temple was situated in the vicinity of the western city-gate, (*vicinum portis civitatis qua parte occasum spectat*). Judging by the further statements, it could be understood that the temple also was situated outside the town because Auxibius had to pass through the temple (*transeuntem*) on his way from Limenia

to Soli, and later, when teaching Christianity in the town it is clearly set out that he stayed as the priest's guest in the temple and hence went into the town and back again (. . . *urbem occulte ingrediens et secreto docens, ac rursus recedens, et exiens extra civitatem in praedicto Jovis loco manebat*). It has been argued above, that this temple must refer to a temple known at the time when the Acta were written, which cannot have been earlier than in the 4th Cent. There can be no doubt that the temple-site at Cholades is identical with the place mentioned in the Acta. Under such conditions, there are no other temples possible except Temple E, the middle *cella* of which was sacred to Serapis. This god might well be identified with Jupiter by a Christian author. The following may be the right explanation of this matter: Auxibius passed through the temple site in the middle of the 1st Cent. A. D., and stayed as the priest's guest in some of the temples. The tradition of this may have survived to the 4th Cent., when the Acta Aux. were written. The author, who evidently was well acquainted with the local circumstances of Soli, connected the traditional story of Auxibius with the known topographical conditions in the author's time. Thus we find references in the text to places and localities which actually did not exist at the time of Auxibius (cf. above). The quotation of sculptures in the temple is interesting as the sculptures mentioned most likely are those belonging to Temple E which, under such conditions must have been more or less preserved or remembered when the Acta were written. Evidently Auxibius did not succeed in converting all the citizens of Soli. The temple-site and the paganism survived him and even new temples were built on the same place more than a century after his death. There may be some truth, however, in a suggestion that the destruction of Temple D at the end of the 1st Cent. A. D., was caused by the activity of Auxibius. There are no sculptures found which can be attributed to the century after the bishop, though it must be admitted that they still may be discovered in the vicinity, perhaps in connexion with the buildings, never entirely excavated, of the second intermediate period.

A. W.



Fig. 289. Soli. The auditorium of the theatre before excavation.

The theatre

ARCHITECTURE (Figs. 289—297; Plans XL, XLI)

ARCHITECTURAL ELEMENTS

Walls.

*Wall 1.**

Width: 0.65 m. Height: 2.00 m.

The wall is built of medium-sized rubble, mixed with river-stones and unworked stones of hard limestone. The construction is rather careless. The W. part of the wall is strengthened by a substructure pillar of stones and much lime-mortar built into the masonry. The N. face of the wall was covered with lime-mortar and on this there had been a coating of stucco painted with simple linear ornaments in green, yellow, and red colours. Several fragments of this stucco were found in the architectural debris. The S. face of the wall

* The numbers of the walls are indicated on the plan, Fig. 311.

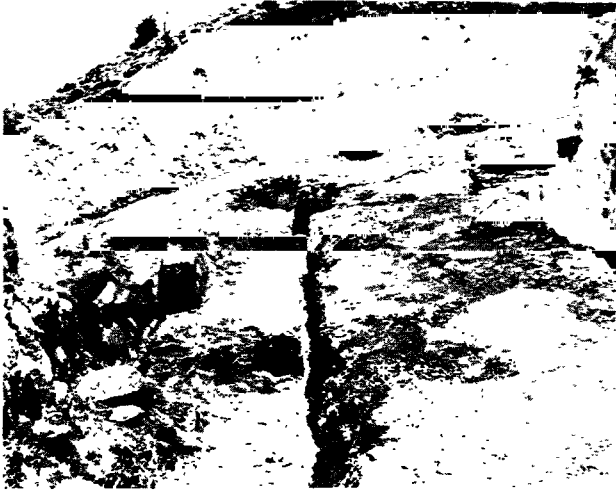

Fig. 290. Soli. The theatre. The eastern diazoma entrance with rock-cut channels for Walls 13 (left) and 14 (right).



Fig. 291. Soli. The theatre. The western diazoma entrance with the rock-cut channel for Wall 17.

was not covered with lime-mortar because the floor of Room II was laid on a higher level than that of Room I and rested on a filling of earth and *chavara*, so that the preserved part of the S. face was never visible. The upper part of the wall seems, however, to have been coated with painted stucco of the same kind as mentioned above.

Wall 2.

Width: 0.70 m. Height: 1.20 m.

The wall is built of irregular blocks of limestone, to a great extent taken from earlier buildings. The stones are joined with lime-mortar and the faces are coated with the same material. On the W. face this coating is preserved down to the rock-floor of the eastern approach of the theatre, while on the E. face it is only preserved to about Level 85.0, by which the floor-level of Room II is indicated. On this lime-mortar there had been a coating of the same stucco as on Wall 1.

Wall 3.

Width: 0.80—1.25 m. Height: c. 1.80 m.

The material and construction of the wall are the same as those of Wall 2. Two doorways in the wall open on to Rooms III and IV. The part of the wall enclosing Room III is much wider than that enclosing Room IV.

Wall 4.

Of this wall only the rock-cut foundation is preserved.

Wall 5.

This wall consists of a rock-cut foundation as the preceding wall.

Wall 6. Width: 2.15 m. Height: 1.80 m.

The wall is very solidly built of limestone blocks of various shapes and sizes, most of which are taken from earlier buildings. The blocks are very firmly joined by hard lime-mortar. The wall is founded in a channel cut in the rock. The solid construction of the wall is explained by the fact that it served as support of the E. wing of the *auditorium*.

Wall 7. Width: 0.30 m. Height: 0.55 m.

This wall is built of rubble, in the E. face kept together by lime-mortar. The wall separates the eastern *parodos* to the orchestra from the entrance ramp to the *skene* and *logeion* and revets the rock-cut platform of the entrance ramp. It has not projected much, if anything, above the floor-level of this platform. It is of too feeble a construction to have sustained the pressure of a superstructure.

Wall 8. Width: 1.05 m. Height: 0.40 m.

Of this wall, only the bottom course is preserved. This is founded in a channel cut in the rock and is built of large, rectangular blocks of limestone joined with lime-mortar. Its lower part revetted the rock-cut platform of the stage-building.

Walls 9—10.

Of these walls no stone foundations are preserved but their width (0.55—1.25 m.) is given by a channel cut in the rock in which the walls were founded. Wall 9 revetted the N. face of the E. wing of the auditorium, and Wall 10 supported and revetted the substructure walls 11 and 12.

Wall 11. Width: 1.70 m. Height: 4.60 m.

The wall is built of rubble and seems to have been erected in two stages, the lower part of the E. face being joined with lime-mortar which is missing in the upper part. The wall is founded on the rock and is a substructure wall for the seats of the E. wing of the auditorium. It is naturally not bonded to any of the adjoining walls which were built of limestone blocks. Between Walls 11 and 12 there is a filling of rubble and earth.

Wall 12. Width: 1.30 m. Height: 4.50 m.

This wall is built of medium-sized rocks of limestone and river-stones wedged by flat chips of stone. No binding material is preserved. The wall seems to have been built in two stages because there is a distinct line of demarcation between its upper and lower parts. Its S. part is strengthened by a substructure pillar of lime-mortar. The N. end of the wall is supported by Wall 6, and the S. end abuts against the rock-cut face below Wall 13. It served the same purpose as the preceding wall. To the E. of Wall 12 there was a filling of earth and rubble which has been supported and revetted by a demolished wall continuing the exterior encircling Wall 15 and corresponding to Wall 10 on the opposite, western side.

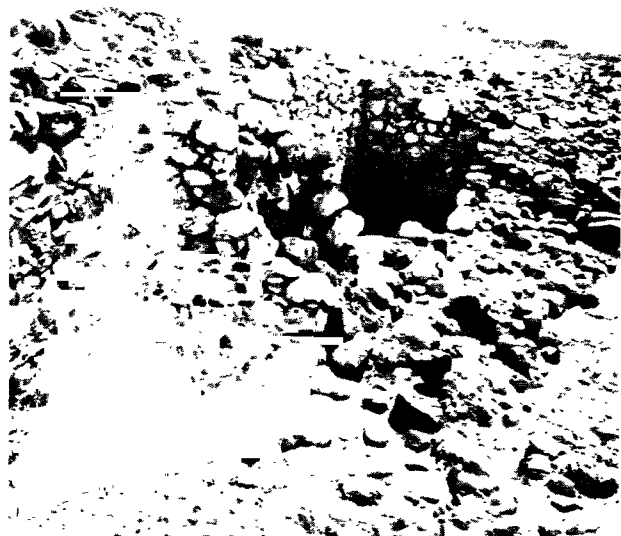

Fig. 292. Soli. The theatre. Rubble structures inside the S. E. part of Wall 16. The filling of earth and gravel supporting the seats in this part of the auditorium was enclosed by these structures.

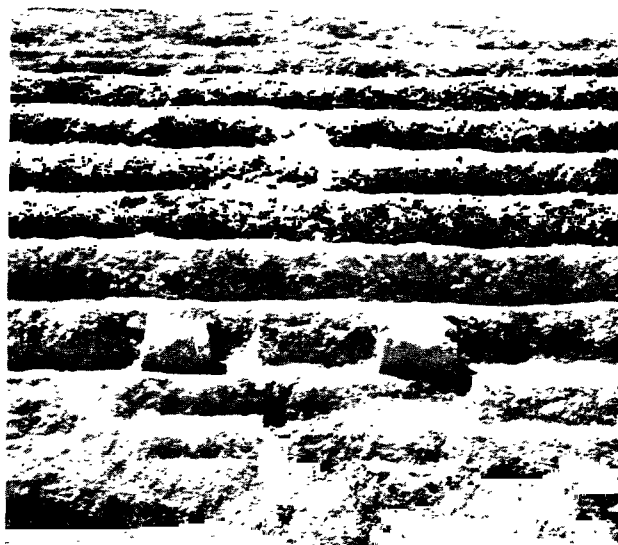

Fig. 293. Soli. The theatre. Detail of the rock-cut rows of seats in the centre of the auditorium.

Wall 13.

Width: 0.90 m. Height: 0.60 m.

Of this wall, only two rectangular limestone blocks joined with lime-mortar are preserved. The wall is founded in a channel cut in the rock.

Wall 14.

Width: 0.90 m. Height: 3.00 m.

The N. face of the wall which probably was built of limestone blocks is not preserved. The interior part of the wall which revets the rock-cut face of the auditorium consists of irregular limestones embedded in lime-mortar. The wall is founded in a channel cut in the rock. Walls 13 and 14 serve as walls of the eastern entrance passage to the *diazoma*.

Walls 15—16.

Width: 1.35—1.50 m. Height: 2.50—3.00 m.

These walls form the exterior and interior encircling walls of the theatre. They run from Wall 14 to Wall 17 in a circular curve, comprising less than a semicircle. They are built of limestone rubble and some river-stones with smaller stones in the interstices and joined with lime-mortar. At about equal distances from each other, substructure bases, square in shape, are built into the walls for strengthening purposes. These bases are constructed of rubble embedded in hard lime-mortar. In Wall 15 the bases are placed nearer each other than in Wall 16, in Wall 15 at an approximate distance of 3.75 m. from each other and in Wall 16 at an approximate distance of 4.50 m. There are sixteen bases in Wall 15 and twelve bases in Wall 16. The walls are founded on the rock. The interval between them is filled with small rubble and earth resting on the rock. This filling was evidently placed there contemporarily with the erection of the walls and that accounts for some lines of demarcation in the masonry of the walls marking the levels of the successive fillings.



Fig. 294. Soli. The theatre. The western paraskenion ramp (left) and the western parodos (right).

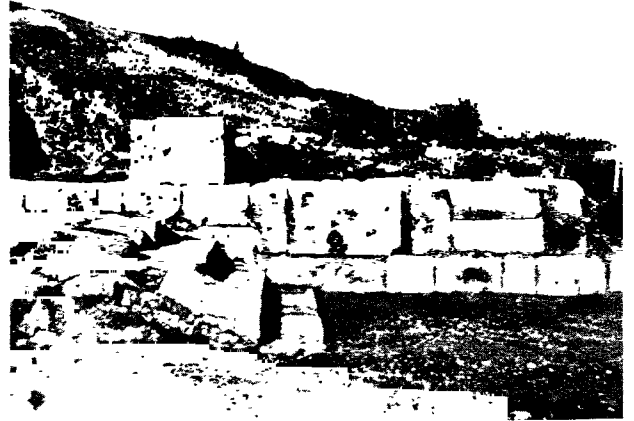

Fig. 295. Soli. The theatre. The staircase of the eastern paraskenion ramp, seen from the East.

Walls 17—18.

Width: c. 0.90 m. Height: c. 0.50 m.

These walls correspond to Walls 13 and 14 on the opposite side and have enclosed the western entrance passage to the diazoma. Of the walls, only single blocks are preserved. They are founded in channels cut in the rock and seem to have been of the same construction as Walls 13—14.

Wall 19.

Width: 2.05 m. Height: 1.60 m.

This wall continues the exterior encircling wall to the N. of the western diazoma entrance, which has been demolished on the opposite, eastern side, and serves as support for the seats of the W. wing of the auditorium. On account of the fact that the rock is higher up than on the opposite, eastern side, substructure walls corresponding to Walls 11 and 12 were not necessary for that purpose. The wall is partly built of rubble, close by Wall 18, and is continued by a massive structure of rectangular limestone blocks joined with hard lime-mortar further to the N. The walls are founded on the rock.

Walls 20—21.

Width: 0.45—0.70 m. Height: 1.50—2.10 m.

These walls correspond to Walls 2, 9, and 10 on the opposite side and form the W. and S. faces of the western parodos to the orchestra. They are built of well-dressed, rectangular limestone blocks joined with lime-mortar and laid in regular, isodome courses. Up to five courses are preserved. The walls revetted the rock-cut face of the auditorium and the W. wing of the theatre in the same way as Walls 9—10 on the opposite sides. They are founded in a channel cut in the rock.

Wall 22.

Width: 0.40—0.50 m. Height: 1.15 m.

This wall corresponds to Wall 7 on the opposite side, and separates the western parodos to the orchestra from the western entrance ramp to the skene and the logeion, and revets



Fig. 296. Soli. The theatre. The eastern staircase from the orchestra to the proskenion.



Fig. 297. Soli. The theatre. The diazoma.

the rock-cut platform of the ramp. The wall is built in two parts. The lower part is built of rubble joined with lime-mortar in the face. This part of the wall was not visible being below the floor-level of the parodos. The lower part of the wall thus served as a socle for the upper part, which is built of rubble with lime-mortar as binding material in the interior of the wall and in the face, too. The wall is founded on the rock.

Wall 23.

Width: 0.60 m. Height: 0.55 m.

This wall corresponds to Wall 8 on the opposite side. Only small fragments of the stone foundation are preserved. The wall was founded in a channel cut in the rock by which its width is given. Its lower part revetted the rock-cut platform of the stage-building.

Wall 24.

Width: 1.05 m. Height: 0.95 m.

The wall is built of well-dressed limestone blocks, rectangular blocks alternating with almost square ones, and covering the whole width of the wall. The blocks are laid in horizontal, isodome courses and are joined with hard lime-mortar and are thus of similar construction to the other ashlar walls. Its lower part, now preserved, revets the rock-cut platform of the stage-building.

Two courses and a part of the third course are preserved. At the S. end of the preserved part of the wall, there is an entrance to the western *paraskenion*. To the S. of this entrance, there are no blocks preserved but the walls can be traced from cuttings in the rock. The wall is bonded to Walls 25 and 30 and is founded on the rock.

Wall 25.

Width: 0.80—1.10 m. Height: 0.50—1.10 m.

This wall forms the back wall of the stage-building and its lower part revets the rock-cut platform of the skene. It is founded on the rock. The construction of the wall is different



Fig. 298. Soli. The theatre from the East. Walls 6, 11, and 12 in the foreground; the auditorium in the background (left) and part of the stage-building (right).

towards the ends and in the middle. Both ends are built of ashlar blocks in the same construction as that of the preceding wall, while the middle part is built of large rubble joined with hard lime-mortar. The wall is strengthened by four square bases of lime-mortar and small stones of the same kind as in Walls 15—16. In the middle, there is an entrance to the subterranean passage below the stage-building (cf. pp. 559, 571), and the wall is bonded to the walls facing this passage. It is also bonded to Walls 24 and 26. Of the ashlar blocks at the ends of the wall, two courses are preserved to the W. and only one course to the E.

Wall 26.

Width: 0.90 m. Height: 0.85 m.

This wall corresponds to Wall 24 on the opposite side. It is built of limestone blocks joined with hard lime-mortar, in the same construction as Wall 24. Up to three courses of blocks are preserved. The lower courses of the N. part of the wall revet the rock-cut platform of the stage-building. In the middle of the wall a door opens on to the eastern paraskenion from the entrance ramp. To the S. of this doorway a part of the wall is preserved. Further to the S. a few more blocks are preserved. Here is another doorway opening on to the paraskenion (cf. pp. 558 f.). The end of the wall is missing.

Wall 27.

Width: 0.95 m. Height: 0.90 m.

This short wall is built in the same construction as that of the previous wall to which it is bonded. The lower part of the wall revets the rock-cut platform of the skene in the same way as Wall 26 and is founded in a shallow channel cut in the rock.

Wall 28.

Width: 0.75 m. Height: 0.25 m.

Of this wall only a single course of a few, well-dressed limestone blocks are preserved. They cover the whole width of the wall and are founded on the rock.

Wall 29.

Width: 0.65 m. Height: 0.10 m.

Of this wall very little is preserved. It is built of rubble without any preserved binding material and of a rather loose construction. The original construction of the wall, however, might have been more solid but this is impossible to ascertain on account of its bad state of preservation.

Wall 30.

Width: 1.10 m. Height: 0.90 m.

This wall corresponds to Wall 27 on the opposite side and is of similar construction to that wall. Two courses of blocks are preserved.

Wall 31.

Width: 1.00 m. Height: 0.40 m.

Of this wall only two limestone blocks and a short piece of rubble are preserved. The wall seems therefore to have been built in a mixed construction of ashlar blocks and rubble.

Wall 32.

Width: 0.85 m. Height: 0.60 m.

This wall has been built of well-dressed, rectangular limestone blocks as the corresponding Wall 40, but only a few blocks at the W. end and a single block of the stone foundation in the middle of the wall are preserved. This latter block is cut concave on the front side, which shows that the wall was provided with a semicircular niche as Walls 40—42. The wall was founded on a low socle of limestone blocks which still remains. Its lower part revetted the rock-cut platform of the logeion. In the W. part a staircase leading to the logeion is built on the wall.

Walls 33—34.

Width: 0.35 m. Height: 0.55—1.25 m.

These walls are built of a single row of well-dressed limestone blocks revetting the W. and N. rock-cut faces of the western side-arm of the subterranean passage below the stage-building. The blocks are laid in horizontal, isodome courses, with alternating joints. The blocks are joined with hard lime-mortar and are founded on a low socle as Wall 32. Two courses of blocks are preserved.

Wall 35.

Width: 0.25—0.45 m. Height: 1.30—1.65 m.

This wall is a continuation of the preceding walls and revets the W. face of the central part of the subterranean passage. The masonry of the wall is of different construction. To about 4.0 m. from Wall 34, it is built of limestone blocks in the same construction as the



Fig. 299. Soli. The theatre. Rooms I—IV in the foreground; in the background: the stage-building (right) and part of the auditorium (left).

preceding walls but the blocks are of unequally hard limestone, so that some blocks have suffered badly from weathering. At about 4.0 m. from Wall 34 there is a vertical joint in the wall, which further to the S. is built of rubble embedded in much lime-mortar. Especially the top of the wall is solidly joined with such mortar. About 2.0. m. further to the N. there is another, vertical joint in the wall and from that point the masonry changes character: the wall is built of rubble but the construction is rather careless and not so solid as in the preceding part of the wall. This N. part of the wall is bonded to Wall 25.

Wall 36.

Width: 0.40 m. Height: 1.65 m.

This wall revets the E. face of the central part of the subterranean passage through the stage-building and is of exactly the same construction as the opposite parts of Wall 35. It is possible that the wall originally continued to the S. corresponding to the opposite part of Wall 35 and that this part of the wall was demolished on a later occasion in connexion with a widening of this part of the passage and was replaced by the oblique Wall 36, but it is also possible, that some loose consistency of the rock necessitated this deviation from the symmetry. At the angle between Walls 36 and 37, a rectangular stone block was found approximately *in situ* across the passage resting on Walls 35 and 36. This block is all that remains of the roof covering the subterranean passage.

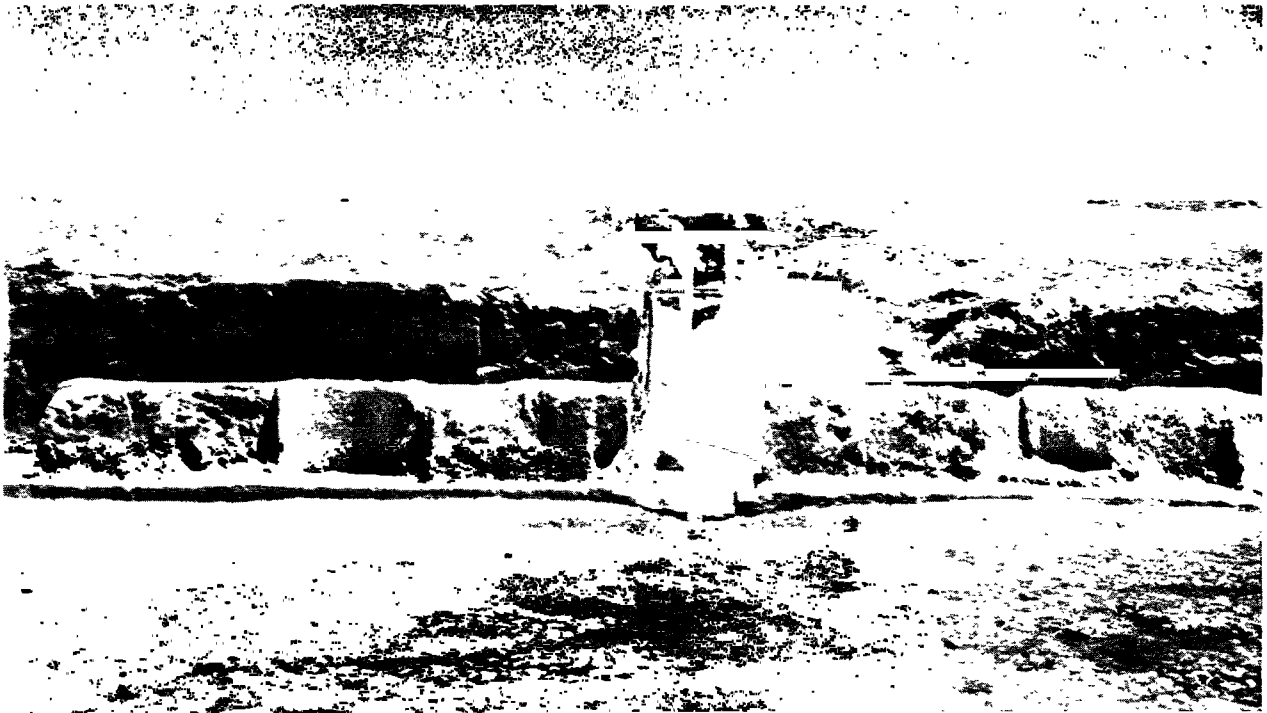

Fig. 300. Soli. The theatre. The proskenion seen from the orchestra.

Wall 37.

Width: 0.35 m. Height: 1.55 m.

This wall is built of a single row of limestone blocks in the same construction as the opposite part of Wall 35, and the S. end of Wall 36. The wall runs from N. W. to S. E. making an obtuse angle with Wall 36, by which this part of the subterranean passage is widened. This irregularity has been discussed above. Three courses of blocks are preserved.

Walls 38—39.

Width: 0.35 m. Height: 1.30 m.

These walls correspond to Walls 33—34 on the opposite side of the subterranean passage and revet the N. and E. faces of its eastern side-arm. They are of the same construction as that of the walls mentioned. Two courses of blocks are preserved and some of them are much weathered. Wall 39 is bonded to Wall 40.

Wall 40.

Width: 0.85 m. Height: 1.15 m.

This wall corresponds to Wall 32 on the opposite side and revets the E. front side of the rock-cut platform of the logeion. It does not, however, abut directly against the rock but there is a filling of rubble and river-stones mixed with lime-mortar between the rock and the revetting wall, owing to the defective character of the rock here which necessitated such strengthening filling. The wall is founded on a low socle of limestone blocks and it is built of a double row of horizontal limestone blocks placed lengthways with alternating joints. The blocks are well-dressed but some of them have suffered from weathering. They are joined with lime-mortar. Two courses of blocks are preserved. In the middle of the wall

the blocks are cut concave, by which a semicircular niche is formed, 0.88 m. in diameter. On each side of the niche are two plain pilasters cut in the blocks in low relief. In the E. part of the wall a staircase, leading to the logeion, is built on the wall.

Walls 41—42.

Width: 0.90 m. Height: 0.70 m.

These walls form the middle part of the front wall of the logeion. They are of a similar construction to that of the preceding wall but only one course of blocks is preserved. In the middle of the walls are semicircular niches flanked on each side by single pilasters in low relief, of the same kind as in Wall 40. Between this wall and Wall 41, between Walls 41 and 42, and between Walls 42 and 34 open three doorways on to the subterranean passage cut in the rock below the stage-building. As Walls 34, 40—42 form the front wall of the logeion, it can be inferred that their original height was on a level with the floor of the logeion.

Besides these walls which are more or less preserved, there have been other walls which can be reconstructed with a high degree of certainty. These are Walls 43—47. Wall 43 is proved by its correspondance to Wall 28, Wall 46 by its correspondance to Wall 31, and Wall 47 by its correspondance to Wall 29. The location and reconstruction of Walls 44 and 45 will be discussed in the architectural synthesis.

Doors and Gates.

Several doorways and gates opening in the walls afford communication between the different parts of the theatre.

At the interior ends of the W. and E. parodoi leading to the orchestra there is a substructure of limestone blocks extending from the E. end of Wall 23 and the W. end of Wall 8 to the opposite Walls 21 and 9. The blocks are joined with lime-mortar. It cannot be doubted that there were doorways at these places because these parts of the parodoi were covered by vaulted roofs (cf. p. 564) and fragments of semicircular door cornices of marble were found in the architectural debris at these places, but the fragments are too small to be reconstructed with certainty. At the exterior ends of the roofed-in parts of the parodoi there must have been similar doorways, and similar threshold substructures are preserved at that place in the western parodos. As there are no traces of holes cut in the blocks for the door-jambs it seems indicated that the doorways were open and not closed by doors.

The entrance passages leading to the diazoma were covered by vaulted roofs, too, and have ended with similar doorways to those in the parodoi leading to the orchestra, indicated by the find of a fragment of a semicircular marble cornice in the W. passage. At the exterior end of the western passage there are some limestone blocks of the threshold substructure preserved. The blocks are somewhat removed from their original position.

In the stage-building several doors afford communication between its different rooms.

In Wall 26 there were two doors opening from the E. entrance ramp on to the E. paraskenion. The position of the northern door is given by the preserved substructure blocks for the threshold with rectangular, shallow cavities for fixing the wooden door-jambs. This door was 1.10 m. wide. The position of the southern door, too, is certain. It was a double

door, 2.80 m. wide. Only the N. half of the threshold substructure is preserved, with a rectangular, shallow cavity for the door-jamb and a circular hole for the bolt by means of which the door was fixed. Similar doorways opened in Wall 24 from the W. paraskenion. Of these, only a part of the substructure for the threshold of the N. doorway, with a rectangular hole for one of the door-jamb is preserved.

A doorway at the W. end of Wall 27 opens on to Room XV and a flight of steps (cf. p. 560) leads up to the door. A similar doorway at the E. end of Wall 30 opens on to Room XVI and is approached by a corresponding flight of steps. These doorways are 1.10 m. wide.

In the middle of the back wall of the skene a narrow doorway opens on to a subterranean passage below the stage-building. Substructure blocks for the threshold of the usual kind and square holes for fixing the wooden door-jamb are preserved. The door is only 0.75 m. wide.

In the front wall of the logeion (Walls 40—42) three narrow doorways open from the orchestra on to the subterranean passage below the stage-building. No substructure for the thresholds or holes for the door-jamb are preserved, and it is possible that these doorways were not closed by doors.

The doorways in the reconstructed walls of the stage-building will be discussed in the architectural synthesis.

Finally, there are two doorways opening from Room II on to Rooms III and IV. The doorways are 1.00 m. and 1.30 m. in width respectively. Nothing of the substructure for the thresholds is preserved. It is, however, to be noticed that the sides of the doorways are strengthened with rubble and lime-mortar while the remaining part of the wall consists of cut rock only.

Floors.

There is only one floor preserved in the theatre, viz. that of the orchestra. This consists of a substructure of rubble, small pebbles, and fragments of terracotta with a covering floor stratum of lime-cement, of which some parts were preserved.

In other parts of the theatre once covered with floors, these were entirely destroyed and only the filling of earth, gravel, and *chavara*, etc., sometimes used for the substructure of the floors, are preserved. Such fillings were found in Rooms II—IV, in the W. entrance passage to the diazoma and the N. part of the W. parodos to the orchestra. In the remaining parts of the theatre, i. e. the E. entrance passage to the diazoma and the E. parodos to the orchestra, the E. part of the W. parodos (Room VIII), and the stage-building the floors seem to have been laid direct on the levelled rock.

Staircases.

From the N. end of Wall 7, between that wall and Wall 26, a stair of four steps leads to the E. entrance ramp of the stage-building. The steps are built of almost square limestone blocks, as a rule, 4—5 in each step. The blocks are joined with lime-mortar. The stair is 2.05 m. wide and the steps are 0.16—0.23 m. in height. The E. side of the stair is bordered with limestone blocks joined with lime-mortar and laid on the sloping substructure of Wall

7, which follows the inclination of the stair. Two blocks of the middle steps are partly cut out of blocks bonded into Wall 26 which shows that the stair and this wall are contemporary.

A corresponding stair is built on the opposite side leading to the W. entrance ramp of the stage-building. The construction is the same as in the previous stair. Five steps are represented but there was at least one more step at the top end which is now destroyed. The top of the bordering stones, too, is destroyed. One block of the fifth step seems to be bonded into Wall 24.

In the W. parodos there are two pairs of steps descending from the higher level of the exterior doorway of the parodos. The steps are built of square and rectangular limestone blocks joined with lime-mortar; the steps extend across the whole width of the parodos and are 0.11—0.22 m. in height.

On the opposite side, in the E. parodos, there are no remains of a stair left. The level of Room V, however, is about 1.35 m. higher than that of Room VII, and a vertically cut rock wall aligned with the N. face of Wall 6 separates the two rooms. In order to obtain communication between the rooms and access to the orchestra, it is therefore necessary to assume the existence of a stair in this place. As no remains of it are left it seems most likely that it was made of wood.

Along the exterior face of the back wall of the stage-building (Wall 25) there are remains of two stairs, one near the W. end of the wall and the other at the E. part of the wall. The W. stair is built of limestone blocks joined with lime-mortar. There are three blocks in each step. Three steps are preserved. The stair is 1.35 m. wide and the steps are 0.17—0.20 m. in height. The E. stair is much narrower, only 0.70 m. wide, and is built of single limestone blocks. The steps, of which two are preserved, are 0.24 m. in height. Both the stairs lead to the back rooms of the stage-building.

At the W. end of Wall 27, a stair of four steps leads to the higher level of Room XV. The steps are built of square and rectangular limestone blocks, joined with lime-mortar. There are two or three blocks in each step. The stair is 1.10 m. wide and the steps are 0.12—0.19 m. in height. The lowermost step is bonded into Wall 27. A similar stair is found on the opposite side, leading to the higher level of Room XVI; this stair is in a bad state of preservation, but seems to have been an exact parallel to the previous one.

Two stairs lead from the orchestra to the logeion, one at the E. end of its front wall and the other at the W. end of the same. The E. stair is best preserved. It is built on Wall 40 and starts from a rectangular landing block projecting somewhat from the exterior line of the wall. The steps are built of single limestone blocks, joined with lime-mortar. They are 0.45 m. wide and 0.18—0.26 m. high. Five steps are preserved. The stair at the W. end of the front wall of the logeion is of the same construction but has been largely destroyed.

These are the preserved remains of stairs. Besides, there must have been other stairs leading to the upper story of the stage-building. To judge from the arrangements in better preserved theatres of the same type as this (cf. p. 571), it seems most probable that such stairs of shift type were built into Rooms XV and XVI. On account of the bad state of preservation of these parts of the theatre no remains of the stairs are left.

C o l u m n s.

The material used for the columns are different kinds of marble. The column shafts are made of light-coloured, greenish or blue-veined marble; light-blue or greenish, white-veined marble; light-coloured, red-veined marble; greyish, greyish-blue or green, white-veined marble; dark-blue marble; dark or dark-violet marble with white dots; the capitals are usually made of light-grey or greyish-blue marble.

To judge from the preserved fragments, three dimensions are represented:

1. Lower base diameter 0.53 m.
 Upper base diameter 0.465 m.
 Base height 0.14 m.
 Lower shaft tablet diameter 0.445 m.
 Lower shaft diameter 0.385 m.
 Upper shaft tablet diameter 0.35 m.
 Upper shaft diameter 0.31 m.
2. Lower base diameter 0.48 m.
 Upper base diameter 0.42 m.
 Base height 0.125 m.
 Lower shaft tablet diameter 0.40 m.
 Lower shaft diameter 0.35 m.
 Upper shaft tablet diameter 0.32 m.
3. Lower base diameter 0.265 m.
 Upper base diameter 0.235 m.
 Base height 0.07 m.
 Lower shaft diameter 0.193 m.

These measurements are given by the fragments found in the theatre. As no column was there found entirely preserved, their length would be only approximately known, but for the find of a column which at the time of our excavation was lying outside the Custom house in Karavostassi. This column is of the same grey-bluish marble as some of the fragments found in the theatre. Further, it shows the same proportions as the columns of Type 1 in the theatre, its lower diameter being 0.385 m. and its upper diameter 0.31 m. It is therefore to be assumed that this column was once used in the architecture of the theatre and that it has been dragged down to the sea-shore at the demolition of the theatre to be re-used for some purpose. The column has a length of 2.96 m. We may thus safely assume that the length of the columns of Type 1 was 2.96 m. This length displays a proportion of about $7 \frac{2}{3}$, between shaft diameter and length, $7 \frac{2}{3} \text{ m.} \div 0.385 \text{ m.}$ being about 2.96 m.

Assuming that the proportions of the other types of columns were the same we may thus estimate the length of Type 2 to about 2.68 m. and the length of Type 3 to about 1.48 m. Type 2 is thus about 9% shorter than Type 1 and Type 3 measures half the length of Type 1.

The shafts of the columns are both plain and grooved. The grooves are spirally wound. Such grooved columns are only represented in dark-blue marble of Types 1 and 3. No fragments of Type 2 were grooved. The grooves of Type 1 are 3.5 cm. wide and those of Type 3 are 3.0 cm. wide.

The capitals were made of light-grey or bluish-grey marble. Only small fragments were preserved, showing that the capitals were Corinthian. The smallness of the fragments makes a reconstruction of the capitals impossible. The acanthus leaves are roughly cut in low relief and are usually separated by deep borings.

Cornices.

Several pieces of cornices, but all very fragmentary, were found. They are all of marble of the same kind as the capitals of the columns. The cornices are provided with concave and convex mouldings. Some fragments may belong to the cornice of the architrave, others are cornices of doors, niches, etc. A few fragments are curved. They have evidently been used on arched doorways (cf. pp. 564, 567).

Wall revetment.

To judge from the stratigraphical evidence (cf. p. 563), the upper parts of the walls of the stage-building were built of rubble embedded in lime-mortar. The faces of the walls were revetted by stone slabs of various kinds of marble: light-green marble with dark dots; greenish, blue-veined marble; dark-blue marble; dark-violet, white-dotted marble; light-grey and blue-veined marble; white, red-veined marble. Numerous fragments of this wall revetment were found in the debris of the demolished upper walls.

Roof.

The roof of the stage-building was covered with tiles of terracotta, of which many fragments were found in the architectural debris. The fragments, however, are too small to allow a calculation of their width and length. Two types are represented: 1. Flat, rectangular tile with a raised edge along one short side. 2. A tile of smaller size and trapezoid in section. The tiles of the first type had evidently been used for the proper covering of the roof while those of the second type covered the joints of the juxtaposed tiles of the first type.

STRATIFICATION (FIGS. 309, 310)

The stratification of the debris covering the area of the theatre was uniform all over the place and was composed of the following layers:

1. Surface layer.
2. Layer of dark agriculture earth.
3. Layer of dark agriculture earth, containing some rubble and apparently marking an ancient surface layer on top of the architectural debris formed by Layers 4—5. This layer extends only over the orchestra.

4. Debris of earth, rubble, and lime-mortar, being remains of the collapsed encircling walls (Walls 15 and 16) and sloping from these walls down the auditorium to the orchestra.
5. Layer of debris consisting of rubble, fragments of columns, wall revetment, etc., and much lime-mortar sloping from the stage-building to the orchestra and being remains of the collapsed and demolished superstructure of the stage-building.

From this clear and simple stratification it is evident that the superstructure of the stage-building was ruined first (Layer 5); then the encircling walls collapsed (Layer 4); a surface layer covered the debris (Layer 3); the earth accumulated and was used for agricultural purpose (Layers 1—2).

ARCHITECTURAL SYNTHESIS

The theatre of Soli forms an architectural unity, planned and erected in one piece; as far as the architectural remains allow one to judge, no building periods can be distinguished. The architectural plan, the superstructure, and other chronological evidence (cf. Chronology, p. 581) prove that it is a theatre from the Roman period and in the architectural synthesis this is taken for granted.

The theatre consists of the three normal parts of an ancient theatre: orchestra, auditorium, and stage-building.

The orchestra is cut out of the rock. It is semicircular in shape, with a rectangular addition in front, the semicircle having been protracted with straight lines to the logeion in the direction of the tangents of the semicircle. The semicircle has a diameter of 17.0 m. and the protracted, rectangular part a width of 21.50 m \times 2.90 m. Around the periphery of the semicircle a groove, rectangular in section, is cut in the rock, indicating that the orchestra was separated from the auditorium by a parapet of limestone slabs which were inserted in this groove but these are now removed down to the last slab. The floor of the orchestra was plastered with lime-cement on a substructure of rubble, pebbles, and terracotta fragments. The rain-water falling on the orchestra was carried off by a conduit of terracotta pipes sunk in a groove in the rock below the floor of the W. parodos. The terracotta pipes are only preserved in the N. part of the W. parodos (Room VI), where they were preserved by the earth-filling below the floor.

Two entrance passages lead to the orchestra: the western and eastern parodoi. These are angular, running first parallel with the flanks of the stage-building and then turning at right angles parallel with its front sides. They are 2.65—2.80 m. wide, cut in the rock, and flanked by walls of ashlar blocks joined with lime-mortar. From the entrance to 2.30 m. N. E. of their turning point they were open to the sky which is evident from the fact that the E. side of the W. parodos and the W. side of the E. parodos are there flanked by the entrance ramps to the skene which were open to the sky (cf. below). The remaining parts of the parodoi were covered by vaulted roofs. This is indicated by the following facts.

The W. wall of the western parodos is strengthened by a projection of the wall at the



Fig. 301. Soli. The theatre from the West.

place where the vaulted passage is supposed to begin, and the ramp wall on the opposite side is substituted by the ashlar wall of the stage-building so that a solid substructure for the walls of the vault was obtained, and the same holds good for the eastern parodos.

Furthermore, the auditorium is semicircularly protracted to the E. and W. of the parodoi and the rows of seats are there supported by massive substructures, as shown above (pp. 550, 552). It seems very improbable that these laborious substructure works would have been undertaken if the rows of seats supported by them would have ended at the parodoi, because in such a case only a small area of seats on each side of the auditorium would have been obtained. If, on the other hand, the rows of seats were protracted on top of the vaulted parodoi with rectangular *tribunalia* in front, as was usual in the Roman theatres, this substructure work is reasonably explained. Finally, there were found fragments of semicircular marble cornices in the architectural debris of the parodoi. These facts, then, indicate that the parodoi were covered by a vaulted roof. Both the exterior and interior doorways of the parodoi were probably open but the exterior ends of the open parts of the parodoi may have been closed with a lattice-door. The higher level of the exterior doorway of the western parodos is reached by two pairs of steps. In the eastern parodos the level of the open part is 1.35 m. higher than that of the vaulted part. As there are no traces of

The theatre

Section I

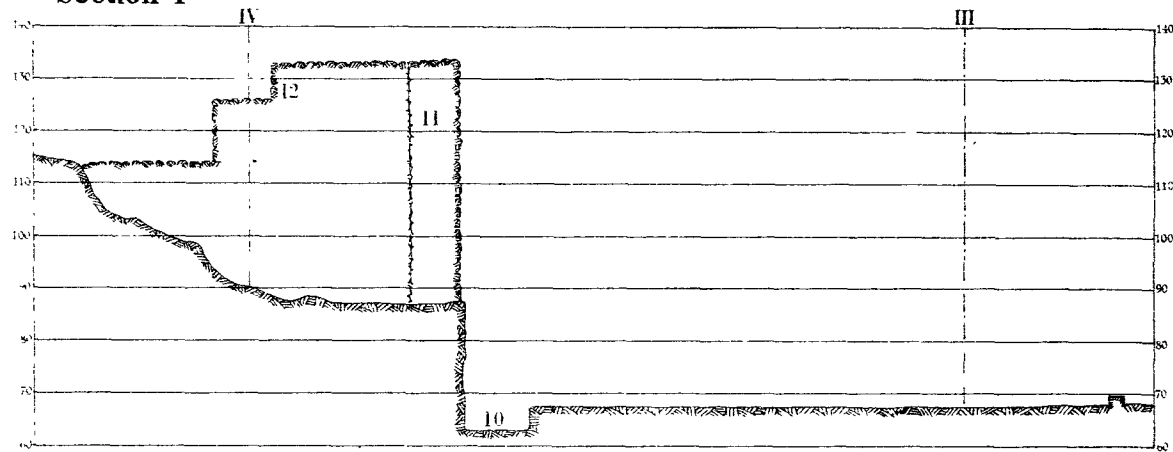

1

Section III

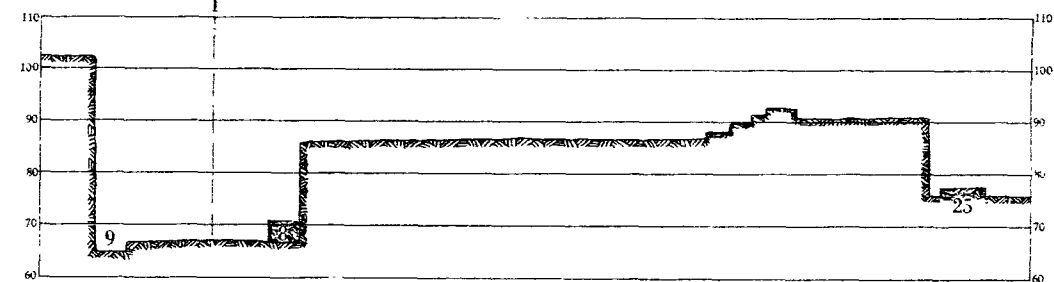

3

Section II

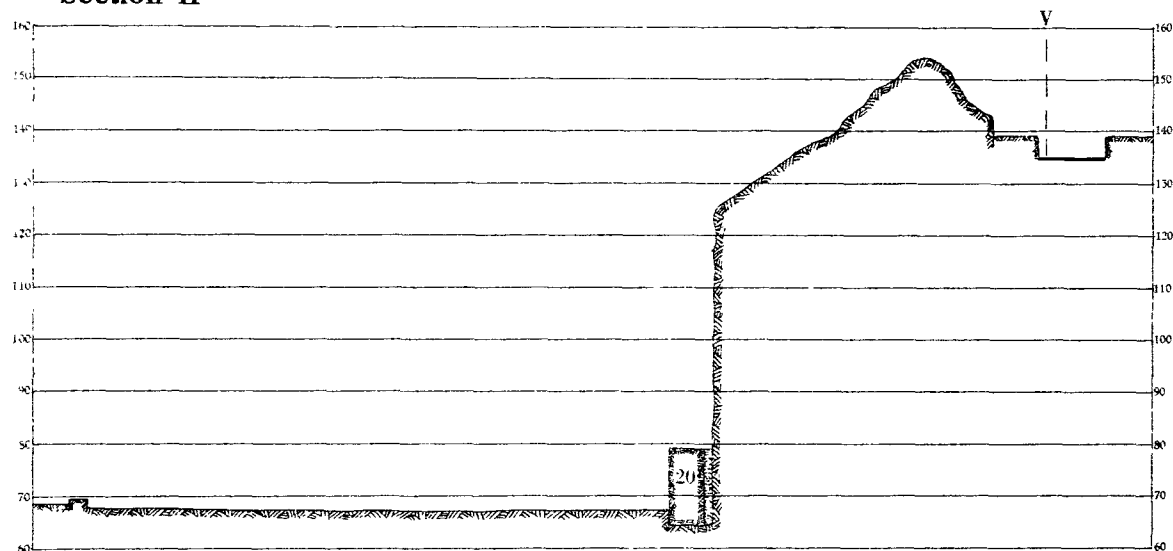

2

Section IV

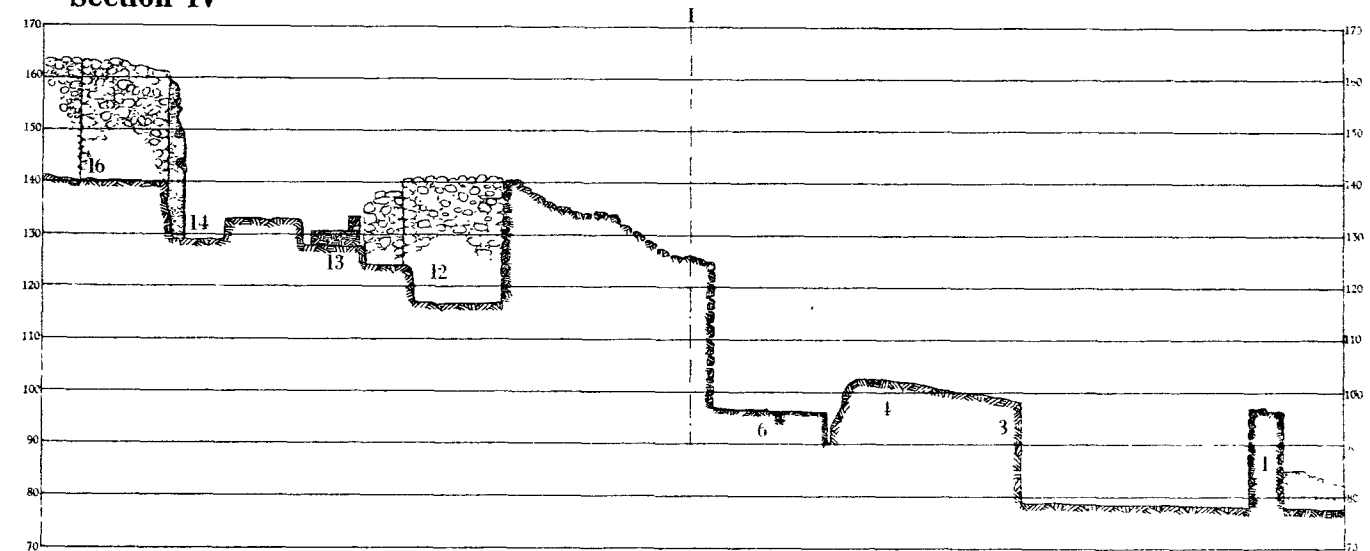

4

Section V

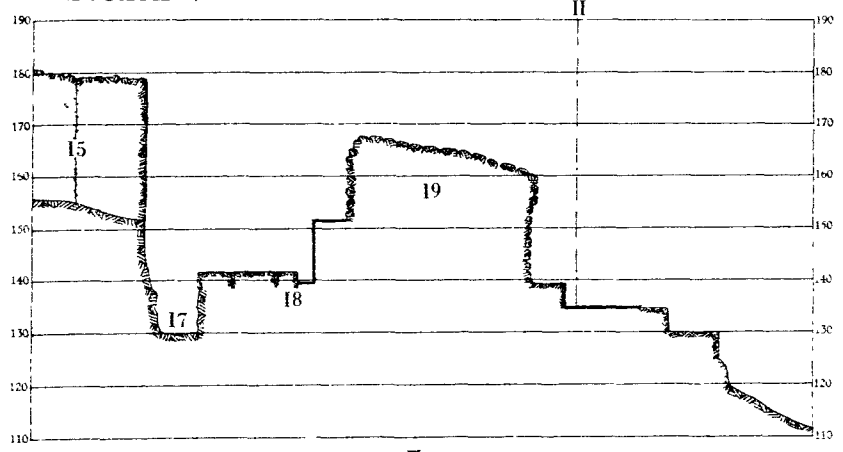

5

Section VI

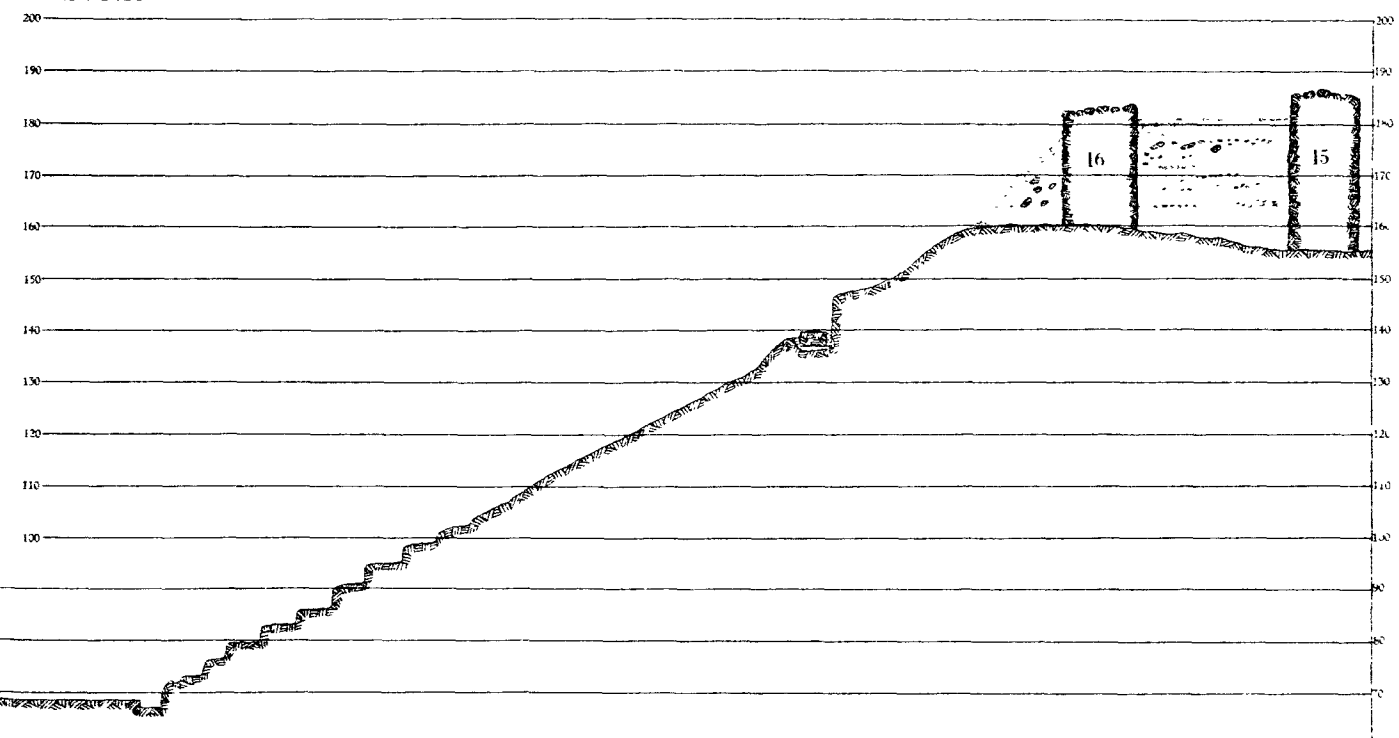

6

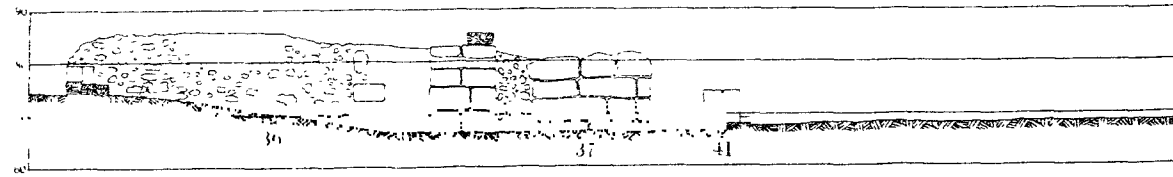

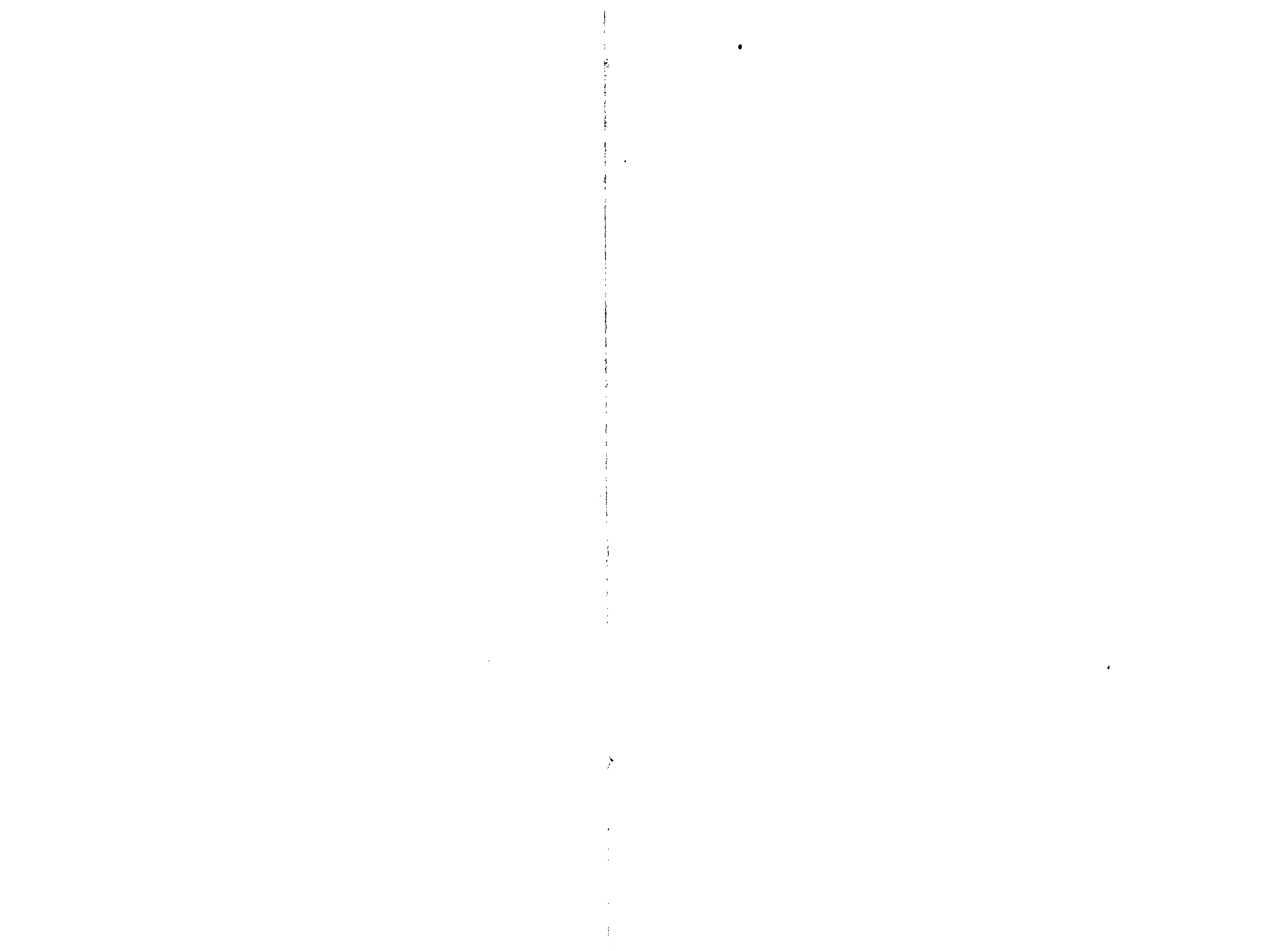

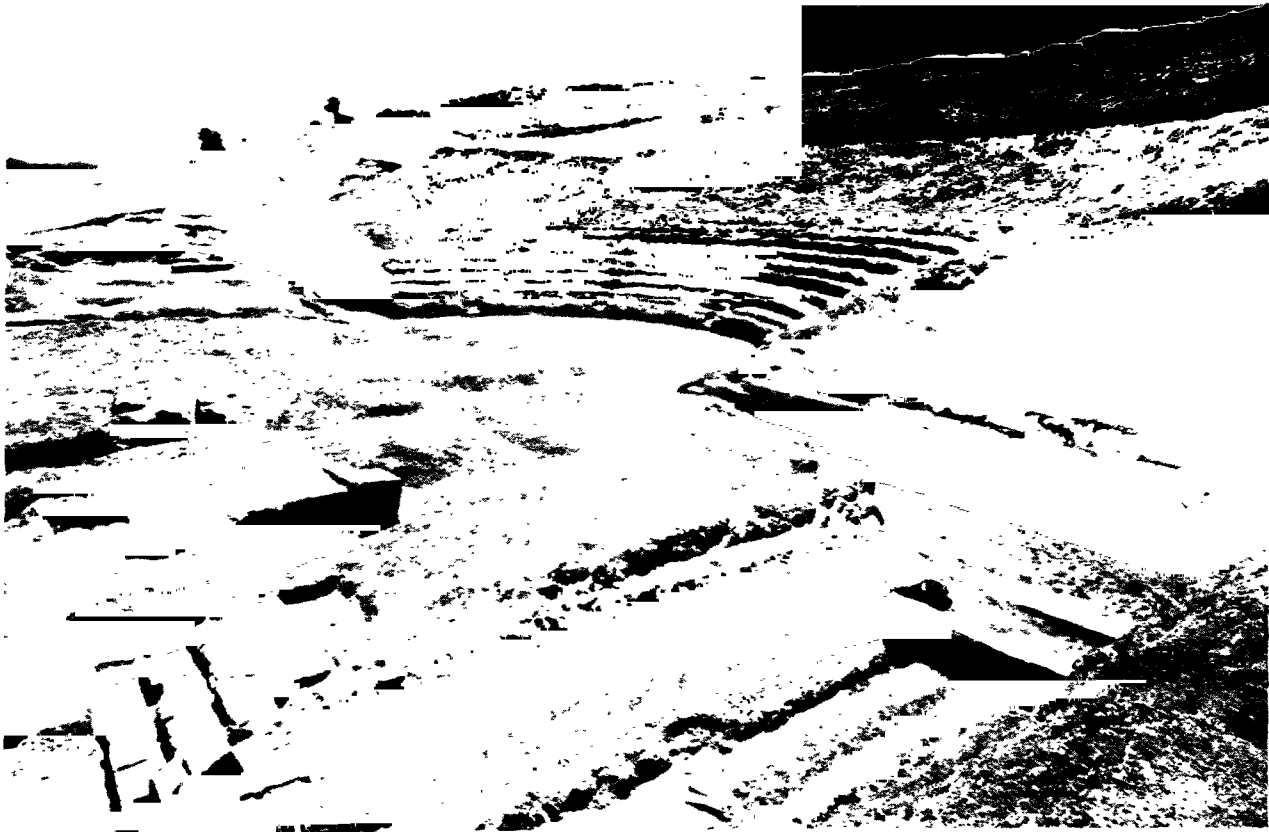

Fig. 302. Soli. The theatre from the N. W.

a stair left and, on the other hand, there must have been a stair at this place if the orchestra was to be entered from this parodos, a wooden staircase probably afforded communication between the two levels of the parodos. In the eastern parodos, 6.50 m. from the entrance to the orchestra, there is a square stone with a hole bored in the middle. The purpose of this stone is uncertain.

The auditorium is semicircular with a diam. of 52.0 m. The greater part of the auditorium is cut in the rock of the sloping hill-side.

Towards the periphery where the rock is defective and concave it is filled in with rubble, gravel, and earth, partly strengthened by rubble structures. The peripheric part is entirely built up on a solid filling of such material supported by the encircling Walls 15—16, and to the N. of the E. wing, where the rock slopes steeply, the seats of the auditorium were supported by massive substructure walls (Walls 11—12).

The auditorium is divided by a diazoma in two circles. The diazoma is 0.55 m. wide and was covered with limestone slabs, of which 31 in the middle are preserved. The blocks are joined with lime-mortar. Along the exterior edge of the diazoma is a narrow groove cut in the rock for insertion of limestone slabs of a similar character as around the orchestra. Along the side of this parapet facing the lower circle there was a water-conduit of terracotta

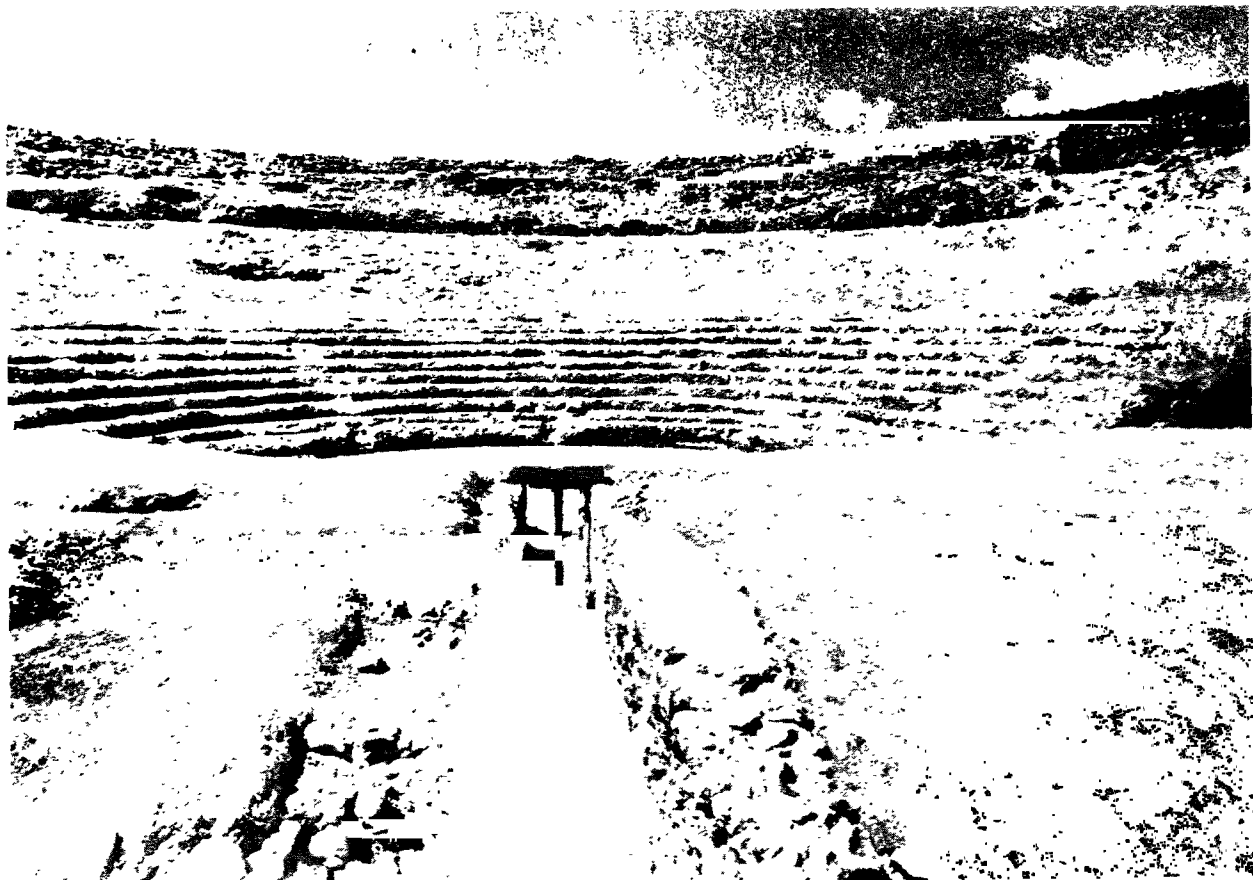

Fig. 303. Soli. The theatre. The stage-building with the subterranean passage in the foreground; the auditorium in the background.

pipes to carry off the rain-water falling on the upper circle of the auditorium. Of these pipes, only some parts are preserved.

The seats are cut in parallel, semicircular rows rising by steps and following the curvature of the auditorium. They were once covered with stone slabs probably of limestone. Of these not a single slab is preserved. The seats are 0.40 m. high and 0.40 m. wide, of which 0.35 m. is reserved for the feet of the person sitting on the row above as can be seen from the preserved, rock-cut bench for the feet beneath the bottom row. Only the nine lowermost rows of seats are still traceable from the cuttings in the rock: on account of the weathering of the rock every trace of the other, superimposed rows has disappeared. By multiplying the width of the preserved rows, however, it can be calculated that the lower circle contained 17 rows and the upper circle 13 rows. The rows of seats were most probably protracted on top of the vaulted parodoi with rectangular platforms, tribunalia, in front (cf. above).

The spectators reached their places on the rows by means of narrow stairs, 0.50 m. wide, radiating from the orchestra and from the diazoma. There are five such stairs dividing the auditorium in six *kerkides* and it is probable that four more stairs of the same kind ran from the diazoma to the periphery of the auditorium in the medial axis of each of the four



Fig. 304. Soli. The theatre. View of the stage-building from the top of the auditorium.

middle kerkides, but this could not be ascertained on account of the weathering of the rock. These rock-cut steps were covered with limestone slabs in the same way as the rows of seats. Remains of lime-mortar by which the stone slabs were joined are still preserved. The height of the steps is half the height of the seats, so that two steps correspond to the height of one row of seats.

Two entrance passages open on to the auditorium from the outside, one to the W. and the other to the E., on the level of the diazoma. The passages are 10.50 m. long and 1.50 m. wide. Their walls are almost entirely demolished but their, apparently, very solid construction, and the fact that a fragment of a semicircular marble cornice was found in the W. entrance passage indicate that they were covered by vaulted roofs. They were closed by doors at their exterior ends which is proved by remains of a threshold substructure in the W. entrance passage.

It can be calculated that there was room for about 3500 persons in the auditorium.

The stage-building is a rectangular building, 36.15 m. long and 13.20 m. wide. It is built on and around a rock-cut platform which forms an excised part of the natural rock. Its front part has a preserved maximum height of c. 2.00 m. above the level of the orchestra while the back part, enclosed by Rooms XV—XIX, is 0.35 m. above that level.

The foundation walls of the stage-building, as far as preserved, are built of ashlar blocks joined with lime-mortar, except the back wall (Wall 25) which is built of rubble with substructure bases of rubble embedded in hard lime-mortar. The upper walls, as shown by the architectural debris (cf. Stratification, p. 563) were built of rubble joined with lime-mortar and revetted by slabs of various kinds of coloured limestone and marble.

The stage building consists of three parts: logeion, paraskenia, and skene. The length of the logeion is given by the side-walls of the paraskenia and its height by the height of the rock-cut platform which served as substructure for the floor of the logeion. Its width is not directly given, but can be calculated with a high degree of certainty. The front wall of the logeion is preserved and gives the one fixed point for this calculation; the back wall, i. e. *scaenae frons*, on the other hand, is missing.

It is well known that Vitruvius states that the face of *scaenae frons* in the Roman theatres should coincide with the base line of an equilateral triangle inscribed in the continued circle of the semicircular orchestra¹. In the plan of the Vitruvian theatre, the front of the *pulpitum* coincides with the diameter of the orchestra, which is not the case in the theatre of Soli, and many other Roman theatres, too. If we, however, consider the front wall of the logeion to be the diameter of the orchestra and fix the base line of the corresponding equilateral triangle in the circle of that diameter we obtain the line A—A on Fig. 312. It can be seen that this line coincides with the N. flanks of the S. doorways of the paraskenia. Furthermore, if we continue the circle of the orchestra we obtain the tangent B—B parallel with the diameter. Adding the normal width of a wall to that line we obtain the line C—C. This coincides with the S. flanks of the N. doorways in the paraskenia and it is also worthy of notice that this line approximately coincides with the N. end of the ashlar wall facing the sides of the rock-cut, subterranean passage through the stage-building. Finally, if we continue the circle with centre in the front line of the logeion we obtain the tangent D—D parallel with the diameter of that circle. Adding a mural width of c. 0.75 m. to that line, we obtain the line E—E which coincides with the higher, rock-cut platform in the back part of the skene.

From the coincidence of these lines it seems to be most probable that the line A—A represents the front of the *prostas* of *scaenae frons*; furthermore, that the line B—B represents the front face of the wall itself and line C—C the back face of the wall; finally, that line D—D represents the front face and E—E the back face of Wall 45 which separated the back rooms of the skene from its front corridor (Room XX).

The stage-building would thus show the following architectural plan.

The logeion is 23.95 m. long, 5.50 m. wide, and 12.00 m. high. The front wall is decorated with pilasters in low relief flanking semicircular niches in which sculptures once were placed. Three doorways open in the wall on to the subterranean passage which is cut in the rock through the whole width of the stage-building (cf. below). By means of two stairs at the E. and W. ends of the front wall the logeion communicated with the orchestra, and possibly with the paraskenia through doors in the E. and W. walls, though no traces of them are left. In the front wall of the skene there were probably only three doors by which the logeion communicated with the skene, corresponding to the three doors in the front wall of the logeion, but there may have been five doors as is often the case in the Roman theatres. It is well known that Vitruvius prescribes that the location of the stairs of the auditorium and the doors in *scaenae frons* should be determined by the angles of four equilateral triangles inscribed in the circle of the orchestra, so that seven angles determine the locations of



Fig. 305. Soli. The theatre seen from the top of the auditorium towards the East.

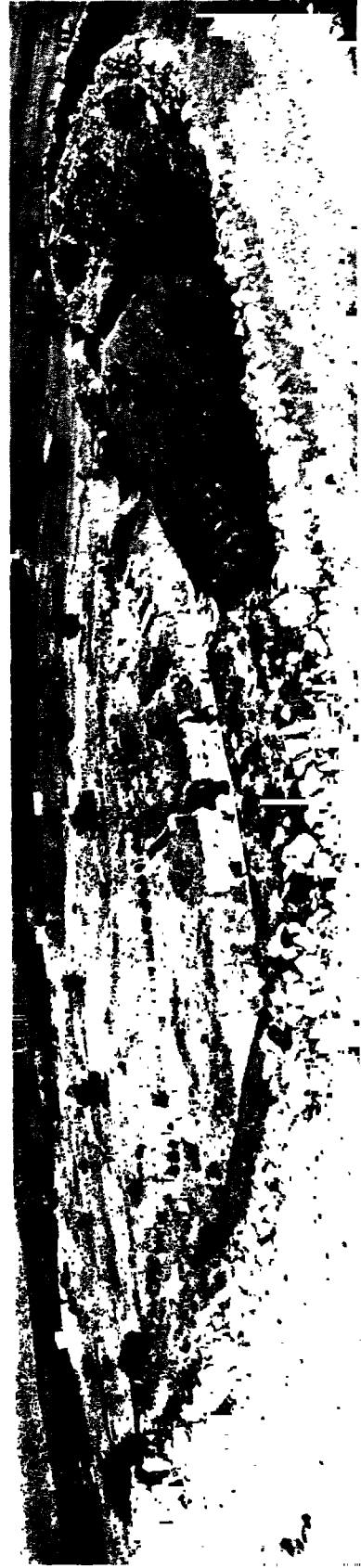

Fig. 306. Soli. The theatre seen from the top of the auditorium towards the N. E.



Fig. 307. Soli. The theatre. Pieces of columns *in situ*, at the E. part of the front wall of the proskenion.



Fig. 308. Soli. The theatre. Detail of Wall 6, with a large, re-used block, possibly belonging to an architrave.

the seven stairs of the lower circle and the other five angles determine the location of the *regia*, *hospitalia*, and the *itineræ versurarum*². It can be seen that the location of the three doors in the front wall is determined by the three corresponding angles of the inscribed triangles (Fig. 312), and we may therefore assume that the same holds good for the corresponding doors, the *regia* and *hospitalia*, in *scaenae frons*, too. The *itineræ versurarum*, if existing, were therefore most probably located in relation to the other two angles of the inscribed triangles which according to the canon, determined the location of the doors.

The superstructure of *scaenae frons* is naturally largely a matter of conjecture and it cannot be reconstructed in detail. The many fragments of columns, however, show that it had the appearance of the usual Roman, ornamental façade, and the many signs of affinity to the well known theatres in Asia Minor, North Africa, Transjordania, and Arabia, etc. (cf. p. 581 and Vol. IV) indicate that the *scaenae frons* of the Soli theatre much resembled those of these theatres, i. e., a *prosta* of columns for each story and a number of niches flanked by columns in the wall.

It has been shown that three different sizes of columns are represented. Type 3 is too short to have been used for anything else but flanking the niches of the wall. Types 1—2, on the other hand, have evidently been used in the *prosta* and indicate a superstructure in two stories, the larger columns (Type 1) being used in the ground-floor and the smaller columns (Type 2) in the upper story.

The *paraskenia* were entered from the exterior by means of open ramps along the short sides of the stage-building, parallel with the N. parts of the *parodoi*. The ramp consists of rock-cut platforms, 7.50 m. long and 1.90—2.15 m. wide, ascended by stairs of four or five steps. Towards the *parodoi* they are revetted by rubble-walls. From each of these ramps two doors, 1.40—3.20 m. wide, open on to the *paraskenia*, the S. doors opening opposite the doors leading from the *paraskenia* to the *logeion* and the N. doors, opposite two other doors leading from the *paraskenia* to the front corridor of the *skene*. The *paraskenia* are



Fig. 309. Soli. The theatre. Section of the debris on the orchestra in front of the proskenion.



Fig. 310. Soli. The theatre. Section of the debris on the orchestra and the western part of the auditorium.

rather narrow and rectangular in shape, measuring 11.50 m. in length and 3.35 m. in width. They are divided into two front rooms (XIII, XIV) and two back rooms (XV, XVI). These, like the back rooms of the skene (cf. below), were on a higher level than the remaining part of the stage-building and were entered by means of stairs of four steps. To judge from corresponding rooms in similar Roman theatres they served as stair-rooms leading to the upper story of the stage-building.

The skene is rectangular in shape and measures 23.95 m. in length and 6.00 m. in width. It was divided into two parts by a longitudinal wall running between the back rooms of the paraskenia (Wall 45), the front part consisting of a corridor (Room XX) and the back part of three rectangular rooms. These rooms were on the same higher level as the back rooms of the paraskenia and must therefore have been reached by means of stairs from the front corridor, if there was communication between this front corridor and the back rooms, which seems most probable. In any case the rooms were also entered direct from the exterior by means of stairs along the back wall of the stage-building.

Through the whole width of the stage-building a subterranean passage is cut in the rock. It is 0.75—1.70 m. wide and 1.65 m. deep, and is entered through a narrow door, 0.75 m. wide, in the back wall of the stage-building. Behind the front wall of the logeion it divides into two angular side arms opening on to the side doors of the front wall of the logeion while its central door is opposite the central part of the passage. Its rock-cut sides are revetted with ashlar blocks from the front of the logeion to the point where scaenae frons passes across the passage. From there and to the back wall of the stage-building it is revetted with rubble (N. part of Wall 35 and Wall 36). The passage was covered with stone slabs of which only one was found approximately *in situ*. Such passages are found in other theatres, too (see Vol. IV). The doors correspond to those of the *hyposkenion* in other theatres though in the Soli theatre there is no *hyposkenion*, as the stage-building is built on a rock-cut platform.

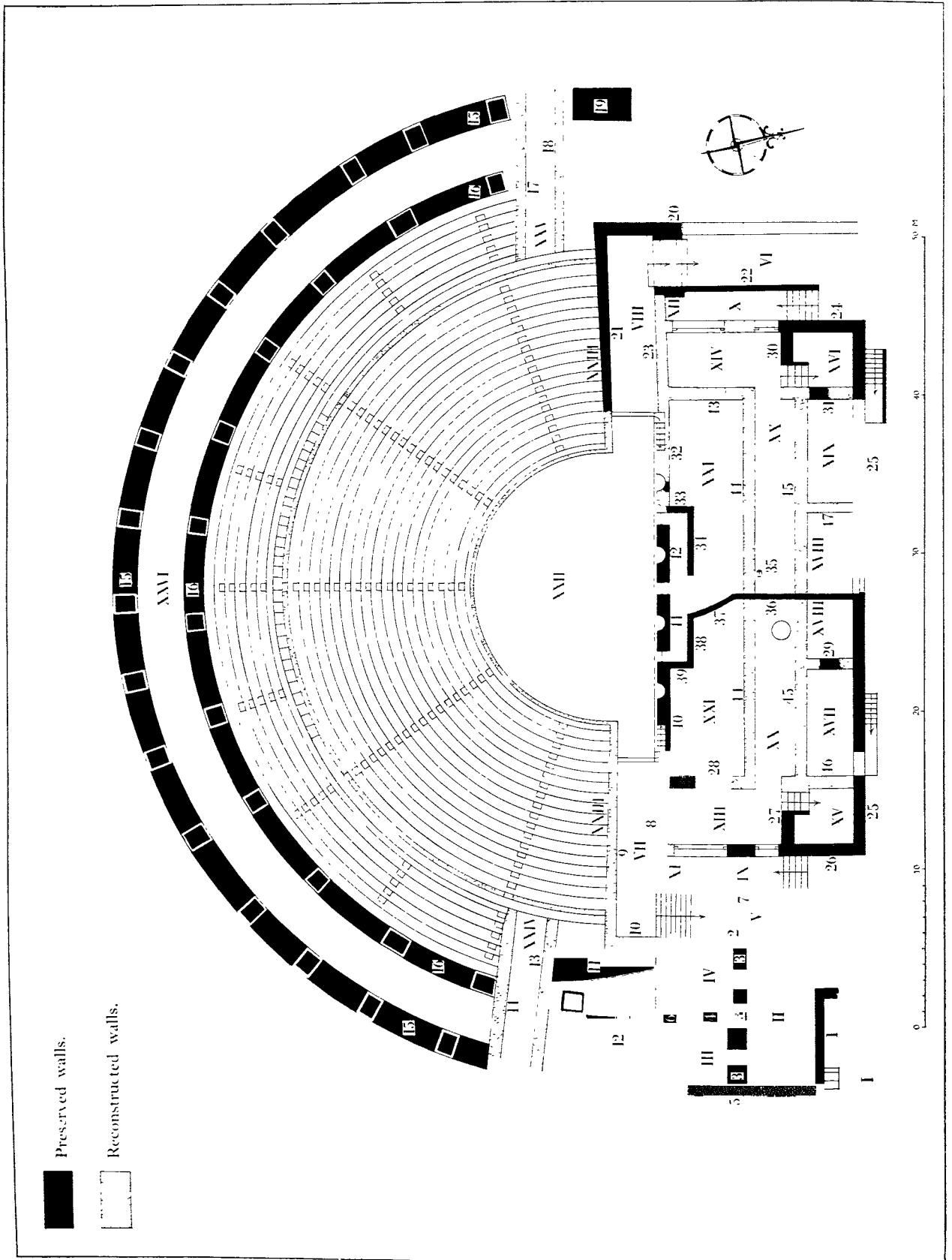

Fig. 311. Soli. The theatre. Analysis.

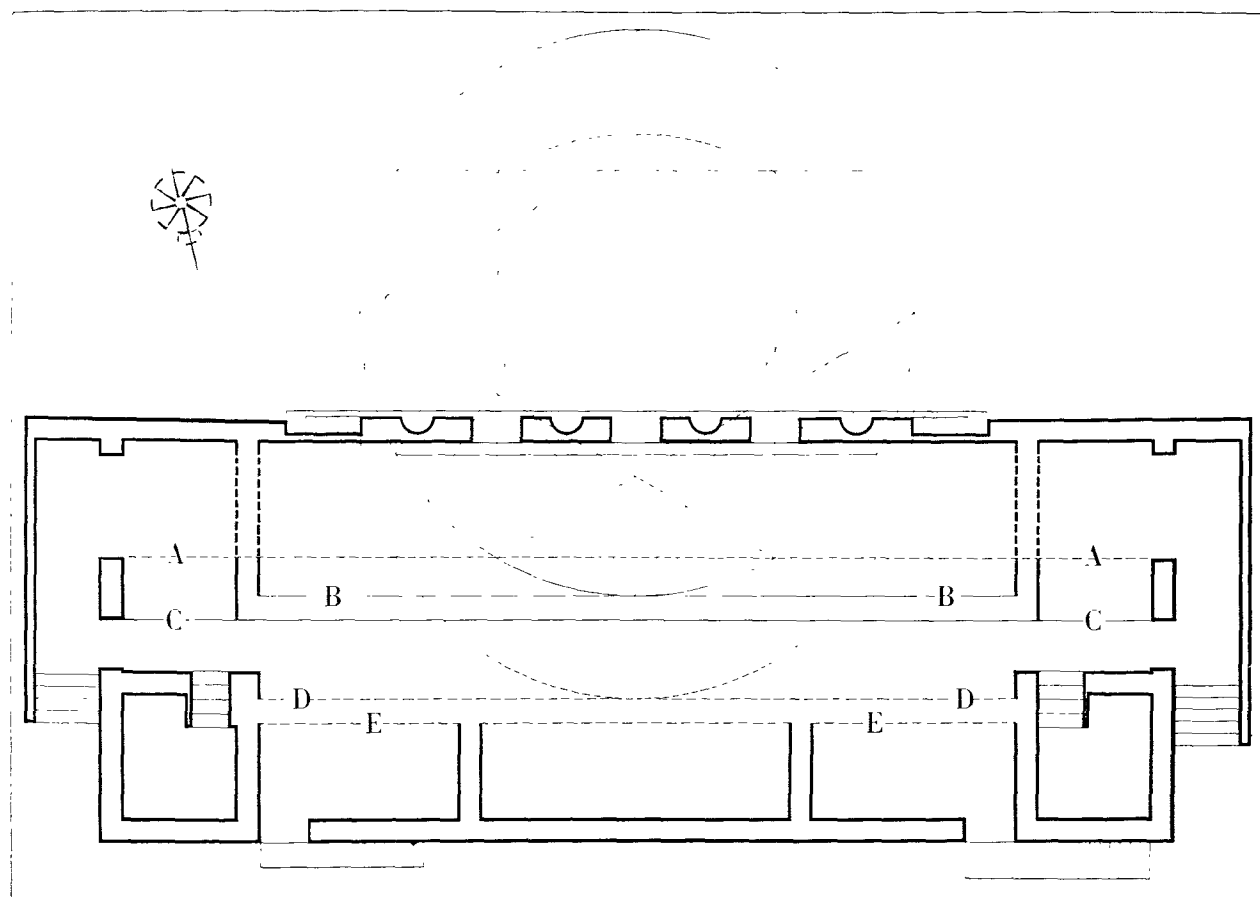

Fig. 312. Soli. The theatre. Reconstructed plan of the stage-building.

In the front corridor of the skene, to the E. of the subterranean passage, a cylindrical well, measuring 1.15 m. in diameter and 18.50 m. in depth, is cut in the rock. The roof was covered by terracotta tiles of the types described above, p. 562.

Apart from the theatre now described there are some rooms adjoining its N. W. corner which form a separate house situated E. of the eastern parodos and N. of the eastern wing of the auditorium. This house contains at least four and possibly more rooms. Of these, Rooms II—IV were entirely excavated and Room I only in parts. The walls of the rooms are built of rubble mixed with lime-mortar and some of them (Walls 3—5) rested on rock-cut foundations. The faces of the walls were covered with stucco painted with simple linear ornaments in green, yellow, and red colours. The rooms are rectangular in shape. Room II measures 4.30 m. \times 8.60 m. Rooms III—IV are smaller, measuring 2.60 m. \times 3.50 m. and 2.85 m. \times 3.55 m. respectively. They communicate with Room II by doors in their front walls. In these rooms the floors were laid on the levelled rock, while in Room II, where the rock slopes, the floor was laid on a filling substructure of earth and *chavara*. No finds were made indicating what the house was used for.

FINDS

OBJECT REGISTER

1. Conical loom-weight of terracotta with a concavity in the base; pierced by a transverse hole near the top. Top missing. Length 5.5. Auditorium. In the architectural debris.
2. Fragment of a horse's head of terracotta with incised eyes; small ears; hogged mane indicated by scratchings; fore-part of head missing. Length 5.8. Western diazoma entrance. In the filling.
3. Upper part of terracotta statuette with flat body; thick neck; oval head with short beard; pellet nose and ears; hair falling in two plaits on each side of neck to shoulders; band around head. Lower part of body and arms missing. Height 7.5. Trial trench N. of stage-building.
4. Bronze nail with button-head; bent. Length 7.0. In the earth above Walls 15—16.
5. Terracotta head, square, with bird-like face; incised mouth with moustache painted black; prominent nose; large pellet eyes, painted black; pellet ears; large, flat, semicircular head-dress decorated with black lines; part of r. side missing. Height 5.8. Western diazoma entrance. In the filling.
6. Moulded terracotta head of a horse with slightly open mouth; one half of head and top missing. Length 4.2. Between Walls 15—16. In the filling.
7. Terracotta lamp, black glazed, with base-disc; erect, almost straight sides; rather short nozzle with horizontal upper side. Top, part of body, end of nozzle missing. Length 9.0. Between Walls 15—16. In the filling.
8. Biconical spindle-whorl of brown, hard clay; pierced by central hole. Diam. 6.2. Between Walls 15—16. In the filling.
9. Flat, circular spindle-whorl of terracotta, pierced by a central hole; decorated with crossed, incised lines on each side. Diam. 4.4. Eastern parodos. In the architectural debris.
10. Fragment of a rider statuette in "snow-man" technique; horse with short peg legs; straight, thin body; rider with legs stretched forward and arms around neck of horse. Parts of legs, tail, neck of horse, and head of rider missing. Length 7.5. Between Walls 15—16. In the filling.
11. Fragment of a bronze fibula; bow decorated with disc-shaped and double-axe mouldings. Length 3.0. In the well of the skene.
12. Three-edged bronze arrow-head with concave sides; pointed end; tubular socket. Part of one edge and socket missing. Length 3.4. Between Walls 11—12. In the filling.
13. Terracotta mask representing a head of ovoid shape; rectangular plaque added below; thick, pinched nose; pellet mouth and ears, plain band around forehead; necklace with a circular pendant; back of vertex and part of plaque missing; pierced hole on top of head for suspension. Length 8.3. Between Walls 11—12. In the filling.
14. Circular bronze ring. Diam. 1.6. W. wing of the auditorium. In the architectural debris.
15. Straight bronze pin, thickening towards the plain top. Length 8.7. Room II. In the filling below the floor.
16. Circular, flat loom-weight of terracotta; pierced by a hole near the periphery. Diam. 7.5. Room II. In the filling below the floor.
17. Four-sided, leaf-shaped bronze arrow-head; double-curved outline; straight tang. Part of tang missing. Length 4.9. Auditorium. In the top debris.
18. Fragment of a Rhodian stamped amphora handle (See Appendix III). Western parodos. In the filling.
19. Straight bone stilus with plain top, pierced by a hole for suspension; point missing. Length 5.8. Room I. In the earth above floor.
20. Terracotta head in "snow-man" technique with rounded beard; pellet mouth; pinched nose; a helmet with straight spike and hanging cheek-pieces. Height 7.0. Between Walls 15—16. In the filling.
21. Two tubular sockets made of shells. Length 1.8. Between Walls 11—12. In the filling.
22. Small, moulded terracotta head of a late Archaic Greek type with oval face; full, slightly smiling lips; leaf-shaped eyes; pellet ears; broad band around head; hair falling in plaits down back of neck. Height 3.3. Orchestra. Top debris.
23. Small, moulded terracotta head of Hellenistic type with wavy hair; veil on top of head; face rather worn. Height 4.3. Stray find.
24. Limestone torso of so-called temple-boy statuette sitting with both legs bent; left leg placed horizontally and right leg vertically; worn surface. No dress details preserved. Broken in three pieces. Height 10.0. In the well of the skene.
25. Flat, circular spindle-whorl of terracotta with central hole. Diam. 3.2. W. wing of the auditorium. In the architectural debris.
26. Fragment of a terracotta bull in "snow-man" technique; modelled brisket; triangular, narrow head; curved horns; pierced pellet eyes; incised mouth; pierced nostrils. L. and part of r. horn missing. Length 5.5. Between Walls 15—16. In the filling.
27. Loom-weight of terracotta, as No. 16. Diam. 7.2. Western parodos. In the filling.
28. Plain White Hellenistic juglet with sack-shaped body; base-disc; neck and handle missing. Height 4.5. In the well of the skene.
29. Circular bronze ring. Diam. 1.4. Western parodos. In the filling.
30. Loom-weight of terracotta, as No. 16. Diam. 7.5. Western part of the skene. In the architectural debris.

51. Several iron nails, some entirely corroded; others with flattened, disc-shaped heads, tapering towards the pointed ends. Length 4.0—8.0. Logeion. On the rock.
32. Four-sided loom-weight of terracotta, splaying towards the base; flat base and top; pierced by a hole near top. Length 6.5. Logeion. In the architectural debris.
33. Loom-weight, as No. 16. Part missing. Diam. 7.5. Logeion. In the architectural debris.
34. Bronze nail with flattened, disc-shaped head; pointed end. Length 6.2. Orchestra. In the architectural debris.
35. Roughly circular lead ring. Diam. 2.3. W. part of the skene. In the architectural debris.
36. Bronze coin. *Obverse*: head of Zeus, looking to the right. *Reverse*: eagle, looking to the left; wings open. Surface much worn. Diam. 2.5. Weight 13.6. Stray find.
37. a—e) Fragments of rider statuettes in "snow-man" technique, consisting of parts of horses with peg legs; short, straight bodies; straight necks with hogged manes; narrow heads with roughly indicated details; riders with legs stretched forward; arms advanced grasping neck of horse; trunk-shaped bodies; roughly modelled heads with pinched noses; pellet ears; sometimes pellet hair. Length 8.0—3.0. a: W. parodos. In the filling; b: stray find; c, e: between Walls 15—16. In the filling; d: W. parodos. Top debris.
38. a—d) Fragments of terracotta statuettes in "snow-man" technique with trunk-shaped bodies; vertical arms; sometimes pellet breasts and uplifted arms; roughly modelled heads with indicated beards; pinched noses; pellet ears; sometimes helmet on head, sometimes band around it. Length 7.0—2.0. a, b: between Walls 15—16. In the filling; c: between Walls 11—12. In the filling; d: orchestra. Top layer.
39. a, b) Two fragments of moulded, female terracotta statuettes, the one with lower part of torso, the other with upper part of torso preserved; draped in chiton and himation of Classical type; the one with r. hand bent over breast, holding object. Length 9.2; 8.0. a: Walls 11—12. In the filling; b: Room II. In the filling below the floor.
40. Various, small fragments of glass bowls and bottles; the glass is blown and iridescent. In the debris.
41. Bronze coin. *Obverse*: **DMFOCA PERAV S**; bust of Phocas, *en face*, bearded; wears crown and consular robe; in r. hand, *mappa*; in l. hand, cross. *Reverse*: XXXX; above, ANNO; to the r. V; below, NIKOA. Diam. 2.9. Weight 11.61. E. paraskenion ramp. In the debris.
42. Bronze coin. *Obverse*: Bust of Probus, radiate, looking r. IMP C M AVR [PROB]VS P F AVG. *Reverse*: emperor standing l. with sceptre, receiving globe from Jupiter standing r. and holding sceptre. CLEMENTIA TEMP. Mint mark worn. Diam. 2.0. Weight 3.45. E. wing of the auditorium. In the debris.
43. Bronze coin. *Obverse*: head of Antonius, laureate, looking r. ANTONINVS AVG PIVS P P TR P XXIII. *Reverse*: three clasped hands. CONCORD COS III S C. Diam. 2.4. Weight 10.22. Orchestra. In the debris.
44. Bronze coin. *Obverse*: head of Antoninus Pius, radiate, looking r. AVKT A AARI ANTONINOCE. *Reverse*: bust of M. Aurelius, bare-headed, looking r. M. ALPHAIOC KAICAR VIOC E. Diam. 3.1. Weight 13.11. Orchestra. In the debris.
45. Bronze coin. *Obverse*: chalice with broad rim and two handles. - - - - X9W *Reverse*: vine-leaf with tendrils. Y X2M X9E Diam. 1.6. Weight 2.42. Western parodos. In the filling below the floor.
46. Bronze coin. *Obverse*: bust of Roma, helmeted, looking l. VRBS ROMA. *Reverse*: wolf suckling Romulus and Remus. Two stars and three dots. Mint mark: SMNE. Diam. 2.2. Weight 2.11. W. wing of the auditorium. In the debris.
47. Bronze coin. *Obverse*: head of Constantinus, laureate, looking r. CONSTANTINVS AVG. *Reverse*: gate of Praetorian camp surmounted by a star. PROVIDENTIAE AVGG. Mint mark: SMANTA. Diam. 2.4. Weight 2.35. Orchestra. In the debris.
48. Moulded, female terracotta head with the hair tied up in a knot at the back of head. Top of head missing. Face details worn. Height 2.25. Between Walls 15—16. In the filling.
49. Moulded, female terracotta head with oval, rounded face; straight nose; rather large eyes; bonnet-shaped hair-dress with small, incised lines. Face worn. Height 3.6. E. wing of the auditorium. In the architectural debris.
50. Moulded, female terracotta head of the Tanagra type with elaborate hair-dress. Height 3.0. E. parodos. In the architectural debris.
51. Torso of terracotta statuette with cylindrical, solid body; uplifted arms; pellet breasts. Head, forearms, and lower part of body missing. Height 7.5. Orchestra. In the top layer.
52. Lower part of moulded, female statuette; dressed in a peplos with vertical folds along left leg; right leg bent and visible below chiton; folded overfold, reaching below hips. Feet and upper part of body missing. Height 7.0. W. wing of the auditorium. Top layer.
53. Narrow horse's head of terracotta with large ears; made in "snow-man" technique. Length 6.6. Room II. In the filling below floor.
54. Moulded lion's head with open mouth and pendent tongue. At the back of head, a cylindrical projection with incised, encircling lines, being the remains of the object to which the lion's head was attached. Length 4.9. Stray find.
55. Head and torso of a Serapis statuette with short full beard and moustache; long, wavy hair and melon-shaped curls; dressed in folded himation. Left arm vertically bent at elbows. White marble. Rough work and badly worn. Height 13.2. E. parodos. In the architectural debris.
56. Fragments of large toga figures. White marble. Heights

- 0.50—0.80. Front area of orchestra. In the architectural debris.
57. Male head of terracotta in "snow-man" technique; pellet nose and ears; conical cap. Height 3.3. W. parodos. In the architectural debris.
 58. Moulded terracotta head; rather trapezoid in shape; straight mouth with full lips; rather thick nose and large eyes; plain hair, helmet with straight spike and hanging cheek-pieces, covering the sides of the head, subsequently attached. Height 4.65. W. wing of auditorium. In the architectural debris.
 59. Arrow-head of bronze; lozenge-shaped blade; thick midrib ending in a tubular socket with a hooked projection. Length 3.65. Room I. In the debris.
 60. Depressed, double-conical spindle-whorl of terracotta, pierced by a central hole. Length 2.7. Auditorium. In the top layer.
 61. Flat lamp of terracotta with flattened base and flat discus, pierced by a small filling-hole; short, rounded nozzle and knob opposite nozzle. Encircling lines of impressed dots on discus and around the edge. Length 7.05. Auditorium. In the top layer.
 62. Lamp of terracotta with base-disc; high, watch-shaped body; closed top with central filling-hole; nozzle with a flat upper side, covered by black glaze. Length 8.5. W. parodos. In the filling below floor.
 63. Mounting of a bronze sheet; adze-shaped with circular top, pierced by holes. Length 5.5. E. wing of auditorium. In the architectural debris.
 64. Thin, circular lid of white, non-transparent alabaster. Diam. 3.4. Front area of the orchestra. In the architectural debris.
 65. Fragment of moulded, female terracotta statuette, wearing mask on left shoulder; dressed in folded himation wrapped around the waist and on left shoulder; right arm slung in a fold of the himation. Surface worn. Only torso down to waist preserved. Height 5.5. E. parodos. In the architectural debris.
 66. Architectural fragments of Doric entablature; found in the filling between Walls 15 and 16.
 - a) *Geson with mutulus and guttae*
Material: porous limestone. Mutulus and guttae are painted blue and the fillet of the geison is red. Height of geison 0.18 m. Height of mutulus 0.012 m. Diam of guttae 0.022 m. Height of guttae 0.014 m. The width of the mutulus is unknown. Three rows of guttae are preserved. If this is the total number of rows which seems most probable, the width of the mutulus has only slightly exceeded that of the preserved fragment which is 0.113 m. wide. The mutulus is horizontal and the guttae are cylindrical.
 - b) *Taenia and regula with guttae*
Material: porous limestone. The taenia is painted red; the regula and guttae are blue. Width of taenia 0.043 m. Height above regula 0.005 m. Width of regula 0.015 m. Height above architrave 0.025 m. Diameter of guttae 0.022 m. Height of guttae 0.025 m.

c) *Triglyphs and metopes.*

Material: porous limestone. The top taenia is painted red; the top border of the triglyphs and metopes is blue; the triglyphs are blue, and the metopes are unpainted. Only fragments were found. Those best preserved are described below.

1. Taenia and top border of the triglyphs and metopes. The width of the taenia is entirely preserved; of the top border only fragments remain. The fragments show that the triglyphs and metopes were cut in one piece. Width of taenia 0.050 m. Height of taenia above border of triglyphs 0.0075 m.; above the border of metopes 0.015 m.
2. Taenia and top border of the metopes. The entire width of the top border and the taenia is preserved together with a small fragment of the metope front. Width of the taenia 0.050 m. Height of taenia above top border 0.015 m. Width of top border 0.045 m. Height of top border above metope front 0.0225 m.
3. Top border of the triglyphs and metopes. The entire width of the top border is not preserved; below the border a small fragment of the triglyph front is preserved. Height of border above triglyph front 0.0075 m. Height of triglyph border above metope border 0.0075 m.
4. Triglyph fragment. The fragment consists of a part of the base of the triglyph front, with the right exterior groove and a small part of the metope front. Width of groove 0.019 m. Depth of groove 0.015 m. Height of triglyph above metope 0.0225 m.
5. Triglyph fragment. This fragment consists of the entire width of a ridge flanked by two half grooves. Width of ridge 0.045 m. Width of groove 0.0185 m. Depth of groove 0.015 m.
6. Triglyph fragment. This fragment, too, consists of the entire width of a ridge flanked by two half grooves. Width of ridge 0.045 m. Width of groove 0.019 m. Depth of groove 0.015 m.

d) *Acroterium.*

Material: soft, white limestone of a more homogeneous kind than that used for the preceding fragments of architecture. A few fragments were found. They are in shape of roughly formed palmettes. The best preserved specimen is a corner acroterium, 0.325 m. in length and 0.175 m. in height. On this, the top is slightly chipped and both ends are missing. The shape of the acroterium can, however, be reconstructed by means of the other fragments, as shown by Pl. CLXXXIV.

67. Ante capital of porous limestone; echinus decorated with a Doric kymation ornament painted in blue and red; moulded abacus. Only about half of the capital preserved. Upper length 0.353 m. Lower length 0.279 m. Height of mouldings 0.610 m. Found built into Wall 17.
68. Bronze coin *Obverse*: Umbrella with fringe; border of dots. ΒΑ[CI]ΑΕΩC ΑΠΠΙΙΑ. *Reverse*: Three ears of barley projecting from leaves; border of dots. [L] 9. Diam. 1.6. Weight 1.3. Eastern diazoma entrance. In the filling below the floor.

CLASSIFICATION OF FINDS

Pottery (Pl. CLXXX).

A Plain White juglet (No. 28) is the only specimen of pottery which was approximately preserved. Besides, numerous fragments of pottery were found. Of these, only the stamped handle of a Rhodian amphora is numbered (No. 18). The unnumbered potsherds consist of Hellenistic and Roman pottery: Black and Red Lustrous, Black and Red Mat, Monochrome Red, Plain White, Coarse, and Grooved wares. The wares are similar in type to those found in the temples of Isis, Aphrodite, and Serapis. These are classified pp. 509 ff.

Sculptures (Pls. CLXXX—CLXXXII).

A roughly made limestone statuette of a so-called temple-boy (No. 24), a marble statuette of Serapis (No. 55), and marble fragments of toga statues (No. 56) are the only representatives of stone sculpture. The style of the Serapis statuette includes it in the group of sculptures of Style IV in the temple of Isis, Aphrodite, and Serapis (cf. p. 528).

The terracotta statuettes are more numerous. They are of the following types:

1. Human idol of the Cypro-Geometric type (Nos. 5, 51).
2. Animal statuette in "snow-man" technique (Nos. 26, 53).
3. Rider statuettes in "snow-man" technique. Probably the fragments of horses belong to this group (Nos. 2, 10, 37).
4. Human idols in "snow-man" technique (Nos. 3, 20, 38, 57).
5. Figural mask in "snow-man" technique (No. 13).
6. Moulded animal statuette (Nos. 6, 54).
7. Moulded Late Archaic statuette (Nos. 22, 58).
8. Moulded statuette of Classical type (Nos. 39, 49, 52).
9. Moulded Hellenistic and Roman statuettes (Nos. 23, 48, 50, 65).

Iron.

Nail with flattened, disc-shaped head (No. 31).

Bronze (Pl. CLXXXII).*Arrow-head.*

1. Four-sided arrow-head; double-curved outline; straight tang (No. 17).
2. Lozenge-shaped arrow-head; midrib; tubular socket, with hooked projection (No. 59).
3. Three-edged arrow-head; concave sides; tubular socket (No. 12).

Pin.

Straight pin, thickening towards the plain top (No. 15).

Fibula.

Fragments of a fibula; bow decorated with disc-shaped and double-axe mouldings (No. 11).

Ring.

Circular, plain ring (No. 14, 29).

Nail.

Nails with button-head (No. 4) and flattened, disc-shaped head (No. 34).

Mounting.

Adze-shaped mounting with circular top (No. 63).

Lead.

Circular, plain ring (No. 35).

*Terracotta (Pl. CLXXXII).**Spindle-whorl.*

1. Flat, circular spindle-whorl, pierced by a central hole (Nos. 9, 25).
2. Biconical spindle-whorl, pierced by a central hole (Nos. 8, 60).

Loom-weight.

1. Conical loom-weight with a concavity in the base and pierced by a transverse hole (No. 1).
2. Four-sided loom-weight, splaying towards the base; flat base and top; transverse hole near the top (No. 32).
3. Circular, flat loom-weight, pierced by a hole near the periphery (Nos. 16, 27, 30, 33).

Lamp.

1. Lamp with base-disc and erect, almost straight sides; short nozzle with flat upper side; black glaze (No. 7).
2. Lamp, as Type 1, but with high, watch-shaped body (No. 62).
3. Flat lamp with flat base and discus, pierced by small filling-hole; short, rounded nozzle and knob opposite the nozzle (No. 61).

Glass.

Fragment of bowls and bottles of blown, iridescent glass (No. 40).

Shell.

Tubular sockets, plain (No. 21).

Alabaster.

Circular, flat lid (No. 64).

Stone (Pls. CLXXXIII, CLXXXIV).

Architectural fragments of Doric architecture (Nos. 66, 67). That these architectural fragments belong to the same building or buildings of equal size is shown by the fact that their measurements, as far as they can be ascertained from the preserved fragments or calculated on the basis of the preserved parts, are in accordance with each other. The length of the regula of the architrave, the width of the triglyphs, and the width of the mutuli are the same, or 0.249 m., as shown below:

Regula and Mutulus	Triglyph
5×0.043 m. (width from centre to centre of guttae) 0.215 m.	3×0.045 m. (width of rid- ges) 0.135 m.
2×0.017 m. (distance from end of re- gula to centre of exterior guttae) . . . 0.034 m.	$3 \text{ m.} \times 0.038$ m. (width of grooves) 0.114 m.
0.249 m.	0.249 m.

Only as regards the acroteria and the ante capital No. 67 it is impossible to say if they belong to the same building or not, but the proportions seem to agree, as far as can be seen.

The fragments are not sufficient to allow a reconstruction of the building. The height of the triglyphs is unknown, as in spite of persistent attempts it was not possible to put the fragments of a single triglyph together. Besides, the width of the metopes is unknown, as only a few, small fragments of them are preserved. As the width of the triglyphs is known the width of the metopes could be determined, if the blocks of the architrave were preserved. There is a block built into Wall 6 of the theatre (cf. p. 550, Fig. 308) which seems to have been an architrave block both on account of its length, which much exceeds that of the other re-used blocks found in the theatre walls, and from the fact that something which may have been a taenia and regulae has been chipped off along one edge of one of its long sides. The material of this block is the same porous, buff limestone as that used for taenia and regulae described above: the block measures 1.305 m. in length, 0.560 m. in width, and 0.450 m. in height. As, however, no remains of the taenia and regulae with guttae are left, by means of which their agreement in size with the fragments mentioned above could have been ascertained, it is impossible to say whether the block belongs to the architrave of the building in question. In view of this, the question could only be solved if the width of the metopes was known. We are thus moving in a circle of unknown quantities and must refrain from an attempt to reconstruct the building. On the basis of the known facts, we can only state the following.

The taenia of the architrave is 0.043 m. wide and projects 0.005 m. above the surface of the regula. It is painted red. The regula is 0.249 m. long and 0.015 m. wide. There are six guttae on each regula; they are cylindrical in shape and measure 0.022 m. in diameter, and 0.025 m. in height. Both the regula and the guttae are painted blue. The triglyphs and metopes are cut in one piece. The triglyphs are 0.249 m. in width; their height is unknown; the ridges are 0.045 m. in width; the grooves are 0.038 m. in width and 0.015 m. in depth; their top is curved. The top border of the triglyphs is 0.045 m. wide and projects

0.0075 m. The triglyphs and their top border are painted blue. Above the top border there is a taenia cut in one piece with the triglyphs and the metopes. The taenia is 0.050 m. wide and projects 0.0075 m. above the top border. It is painted red. In Doric architecture there is usually no such taenia cut in one piece with the triglyph frieze but the part of the geison bonded into the wall is thicker than the projecting part appearing as a fillet between the mutuli and top of the triglyphs. The taenia on top of the triglyphs thus corresponds to this fillet-shaped part of the geison. The mutuli of the geison are horizontal; the guttae are of the same shape as those of the regula but only 0.014 m. in height. They are arranged in three rows. The mutulus and the guttae are painted blue.

The small size of the preserved architectural remains show that the building was of small dimensions. It cannot have been a temple, but may have been a treasury.

Bone.

Straight stilus with plain top, pierced by a hole for suspension (No. 19).

Coins (Pl. CLXXXIII).

All the coins are of bronze: No. 36 is Ptolemaic, probably from the time of Ptolemaeus Philadelphus, but this attribution is not quite certain on account of the worn surface of the coin; No. 68 can be assigned to Herod Agrippa I³; No. 45 is Judaeian and dates from the First Revolt against Rome⁴; Nos. 43 and 44 were struck by Antoninus Pius⁵; No. 42 by Probus⁶; Nos. 46 and 47 by Constantinus⁷; No. 41 by Phocas⁸.

CONDITIONS OF FINDS

The objects were found scattered about in the layers of architectural debris (Layers 4—5), in the accumulated earth on top of that debris (Layer 1—3), and in the filling earth below the floors and between the walls, and the ante capital No. 67 was found built into Wall 17.

It is evident that the objects built into the walls, or found in the filling below the floors and between the walls must be earlier or contemporary with the erection of the theatre. The classification of these objects shows that the majority of them dates from the pre-Roman period, from the Cypro-Geometric to the Hellenistic period (cf. p. 577). This proves that debris taken from earlier culture strata was used as filling material.

The ante capital No. 67 built into Wall 17 shows that even earlier buildings were pulled down in order to serve as building material and, as a matter of fact, a great number of ashlar used in the theatre walls are re-used blocks taken from earlier buildings. Of these, a large block built into Wall 6, is worthy of notice: it seems to have been an architrave block (cf. p. 579). Small fragments of the structures pulled down were thrown in the filling between the walls, especially between Walls 15—16, where many fragments of a Doric entablature (No. 66) were found.

Of the objects found in the architectural debris some are evidently later than the erection of the theatre where they had been dropped on different occasions and were mixed with the architectural debris at the destruction of the theatre. Other objects found in the same debris must, however, be *earlier* than the erection of the theatre e. g. Nos. 49, 50, 57, and 58, which belong to the Archaic, Classical, and Hellenistic periods. This is explained by the fact that the filling between the walls was of course mixed with the architectural debris when the walls were destroyed, slipped down with the filling earth, and were mixed with the objects in the architectural debris.

The objects found in the top layers have all slipped down with this filling earth and were mixed with the surface earth accumulated on top of the architectural debris.

CHRONOLOGY

Already the architectural form of the theatre shows that it is Roman: the semicircular auditorium, the semicircular orchestra with an added, rectangular front space, the straight and angular, vaulted parodoi, with tribunalia, the direct communication between the orchestra and the logeion by means of stairs, etc., and it was shown above, p. 568, that if Roman proportions are used for the reconstruction of the plan of theatre, these proportions actually correspond with the preserved, architectural remains and the traces of those missing; finally, the superstructure, or rather the remains of the superstructure, are entirely Roman: the front wall of the logeion, decorated with pilasters and niches, and the scaenae frons with façade revetment of marble slabs of different colours, with Roman columns in two stories and niches flanked by columns, etc. As there is no evidence that the theatre has been restored, or its plan altered after its erection, it is necessary to infer that it is Roman from the beginning. The chronological problem is to fix its date within the Roman period. The architectural type of the theatre of Soli shows similarity, partly to the Roman theatres in Asia Minor, partly to these in North Africa, Transjordan, and Arabia (see Vol. IV), and is therefore most probably approximately contemporary with these. We know that the theatre in Aspendus was built by the architect Zenon during the reign of Marcus Aurelius and the theatres in Termessus, Sagalassus, Patara, etc., which were erected earlier, were restored and obtained their final form at about the same time. The theatres at Timgad, Khamissa, Dugga, Dshemila can all be assigned to the period of the Antonines, while the theatres in Bosra, Shuhba, and Gerasa may belong to the beginning of the 3rd Century. The date of the Soli theatre seems, therefore, to be the end of the 2nd or the beginning of the 3rd Century.

This date is in accordance with the conditions of finds, too. In the filling below the floors and between the walls, as shown above, sculptural and architectural fragments from the Cypro-Geometric to the Hellenistic period were found. Together with these objects, in the same fillings, there were numerous fragments of Hellenistic and Roman pottery. On the evidence of the pottery we may thus infer that the theatre was built in the Roman period. A more exact *terminus post quem* for the erection of the theatre is given by the coins Nos. 45 and 68. Of these, No. 68 was found in the filling below the floor of the eastern diazoma

entrance and dates from 42¹/₃ A. D. No. 45 was found in the filling below the W. parodos. This coin dates from the First Revolt against Rome 66—70 A. D.

The other coins, however, found among the architectural debris of the theatre itself, range from the time of the Antonines to Constantinus apart from the stray coin of Phocas (No. 41) which must have been dropped there after the destruction of the theatre. The time of the Antonines agrees well with the proposed date of the erection of the theatre and the 4th Century of our era represents the lowest chronological date of its actual use.

E. G.

A R S O S

Besides the sculptures from Levkoniko, excavated in 1913 by Prof. J. L. Myres but unfortunately never published (J. H. S. 1935, p. 239), the sculptures from Arsos constitute the most important series of sculptural material in the Cyprus Museum. The site at Arsos was excavated in 1917 by Mr. M. Markides but due to his severe illness his publication was never brought further than to a written report deposited in the archives in the Cyprus Museum. In connexion with the establishment of the final agreement between the Cyprus authorities and the Swedish Expedition the right of publishing the finds from Arsos, thanks to the generous courtesy of Mr. Markides, was handed over to the Expedition. The following short notes on the excavation and the conditions of finds are based on Mr. Markides' report; and the plan (Fig. 313) is made after his original plan, kept in the Cyprus Museum.

The excavation revealed a few walls arranged according to a rectilinear system but probably belonging to various periods. In the middle of the area investigated, a modern water-tank was situated, at the construction of which some of the walls had been destroyed. Besides, the investigations of Mr. Markides had been preceded by illicit diggings on several occasions. Thus parts of some walls had been removed entirely. This was the case in the western portions of the area. The western part of Wall b—b (Fig. 313) was destroyed in this way.

The majority of the sculptural finds of hard limestone were found in two parallel walls, a—a and b—b (Fig. 313), about 0.70 m. wide. These walls were practically entirely built up of fragments of sculptures, which had been cut in order to fit the breadth of the walls. If a nose or a head of some sculpture projected beyond the width of the wall it was cut off, etc. Evidently the sculptures were brought from a temenos in order to serve as building-stones. As the walls contained sculptures of various epochs it is impossible to make out anything as to their chronology from their position.

The original temenos ground, however, seems to have been preserved at two patches, east of Wall a—a. Here a concrete floor was found, belonging to the walls described above, and below the floor at the area i—i on the plan (Fig. 313) a kind of a floor-level was found

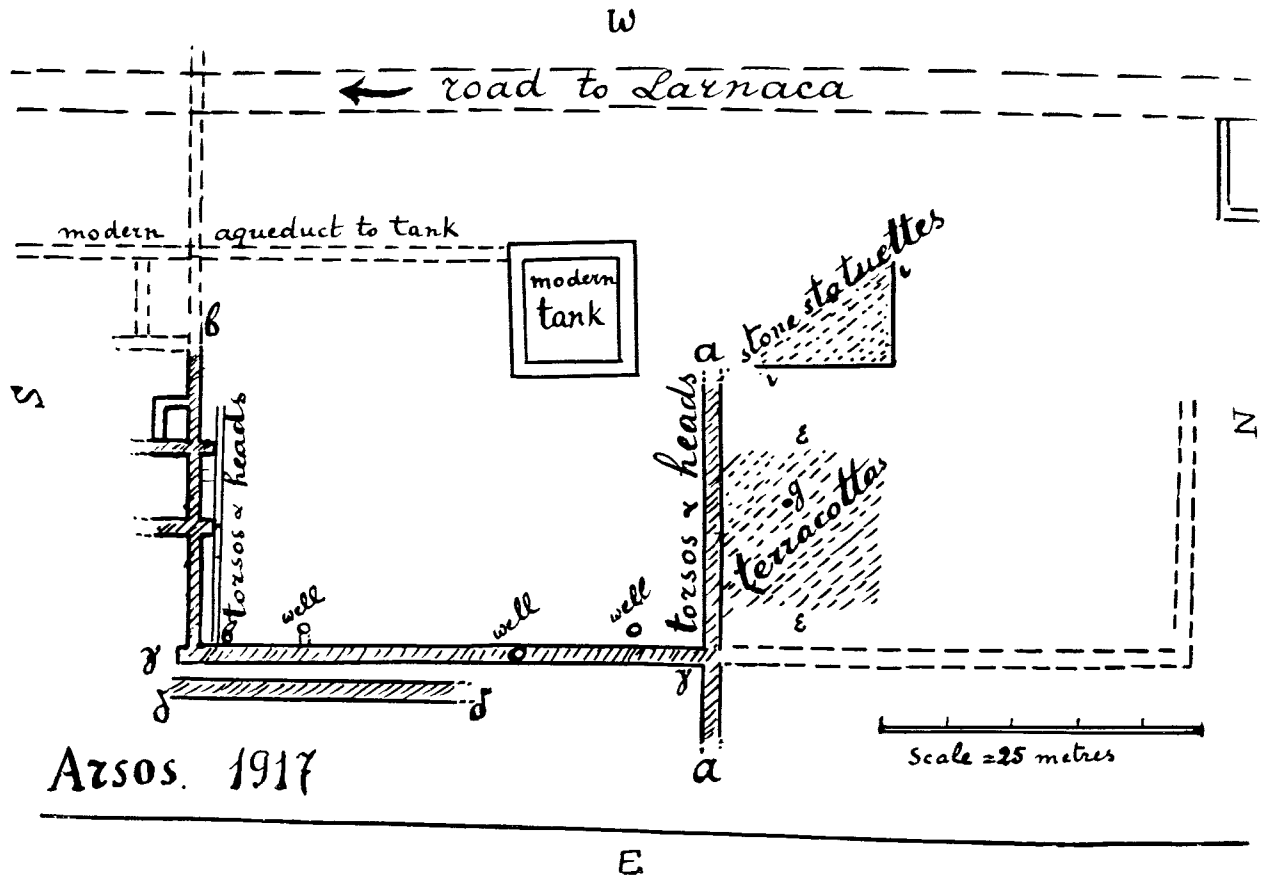

Fig. 313. Arsos. Plan of the excavation in 1917 (after a sketch kept in the Cyprus Museum and drawn by Mr. Markides).

on which a number of stone sculptures were preserved most of them broken but some in better state of preservation.

The terracotta sculptures, however, seem to have been placed separately in this temenos. Nearly all the terracottas were found over the area e—e, about 150 sq. m. Here, too, a great many other minor objects were preserved on the temenos floor, such as beads, scarabs, iron implements, etc. Mr. Markides mentions also a number of Bronze Age vases among the finds from this part of the area. By far the most outstanding finds, however, are the two necklaces of gold. At the spot g within this area, a broken pot was found in the earth, containing both necklaces, and also two bronze cups and a cup of gold. Evidently this constitutes a closed find.

Unfortunately the pottery from this site could not be identified among the collections of the museum. The series of pots mentioned in the report of Mr. Markides may have offered the best indication as to the period during which the temenos was in use.

The sculptures, of course, show that votive offerings were placed in the temenos from the Cypro-Achaic period down to the Cypro-Roman period, but the quotation in Mr. Markides' paper of Late Bronze Age vases seems to indicate that the temenos was used already in the Mycenaean period. According to Mr. Markides the temenos was destroyed in Early

Christian times and the remains, both architectural and sculptural were used as building material for a later building of unknown purpose.

L I M E S T O N E S C U L P T U R E S

The rock which has been used for the sculptures is definitely to be ascribed to the soft kind of limestone though it is of a much harder consistency than the soft limestone of the Vouni-Soli region. This may also explain why so many of the large sculptures are comparatively well preserved. The rock varies somewhat in colour, too, as the Arsos limestone is pale or slightly yellow while the Vouni material is white like chalk. The patina is yellow and rather light and the surface of the sculptures has, as a rule, suffered but little from the destruction caused by acids and moisture in the earth.

The classification of the sculpture, proposed by Mr. Markides, is abandoned here. The researches of the Expedition on other sites and the rich sculptural material obtained in connexion therewith constitute the basis for the following classification of the sculptures, which in this way are put into a system built up on stratigraphical grounds.

Style I.

The sculptures ascribed to this group represent the earliest limestone sculptures of Cyprus. Only female sculptures are represented in the series which is preserved, most of them unfortunately being rather fragmentary. The only preserved head is badly worn, and as to the lower part of the sculptures, only minor fragments are preserved. The series of female sculptures according to which the style is characterized display some very peculiar features which hardly can be explained otherwise than as the expression for a pure Cypriote style, since nowhere are the same kind or similar limestone sculptures met with outside Cyprus except as importations from that island. The development of the earliest limestone sculpture from Arsos cannot be explained otherwise than by a previously existing sculpture technique in terracotta. The sculpture series from Ajia Irini has proved that such an earlier tradition in terracotta really existed in Cyprus.

All the sculptures are built up on a strictly frontal scheme. Their flat proportions give the impression of having been sculptured of a large slab, like a relief. The backs are never finished. The attitude is strictly conventionalized, with a comparatively unsculptured lower part of the body while the upper parts, especially the heads, are extremely carefully executed. We thus note on sculptures of this group most of the features which constitute the peculiar Cypriote characteristics of the further development of the sculpture tradition of the island. While in Greek Archaic sculpture the development of a naturalistic perfection of the bodies is of great importance the Cypriote sculpture is always confined to the expression of the face and the treatment of the various details of the head whereas the bodies are more or less neglected. In pure Cypriote sculptures the body is merely a support, often like a mere column, for the head where the expression is concentrated. This is clearly expressed in the earliest Cypriote sculptures both of terracotta and limestone. A detailed analysis of this early style reveals some more significant features. All the sculptural details are clearly separated from

each other. This holds good especially as to the more elaborate portions, such as the face, the jewellery, the votive offering which always is found in the hand. The feet are isolinear and placed on a comparatively small base. The sides of the body, wearing a long tunic, are more or less parallel. One arm is kept along the side while the other is folded over the breast holding the votive offering, as a rule a bull, sculptured in a surprisingly elaborate style. The female breasts are protruding, almost conical in shape, while the shoulders are wide, somewhat rounded, giving the whole sculpture a very closed contour. The only sculpture on which the head is preserved (Pl. CLXXXV), has a comparatively thick neck around which several, heavy, elaborate necklaces are seen. Though one side of the face is worn away, one can characterize the head fairly well. The details are conventionalized and distinct. The shape of the nose cannot be determined. The eyes are very large with carefully sculptured lids, the upper ones being prolonged somewhat to the side. The brows are made like flat, arched bands above the eyes. It is peculiar how the artist has worked out the jewellery. Apparently this played an important role. This feature can, too, be taken as a trait, typical for the future Cypriote sculpture. The ear-pendants, consisting of large drops suspended from the edges of the ears are especially noticeable. The same arrangement is seen on much later sculptures of Cyprus (cf. below) but the pendants have never been found in gold or any other original material. This, however, is the case with the necklaces. The uppermost necklace on the statue, Pl. CLXXXV, composed by two rows of minor rosettes may well explain the gold rosettes, often found among the burial-gifts in tombs. As to the next two necklaces on the sculpture they evidently represent golden necklaces like those found in Arsos (cf. p. 597) and pictured on Pl. CCV. They constitute the most striking parallels. The fourth necklace consists of a string to which two scarabs with their bezels are attached as pendants. The arrangement has many parallels as well among the Cypriote sculptures (e. g. Vol. II, Pl. CCIX, 3) as among the jewellery in metal (cf. Vol. I, Pls. IV, XLIV).

Style II.

The sculptures ascribed to this style display many characteristics common with those of the previous style. In many respects Style II can be regarded as a direct continuation of the tradition from Style I without much influence from anywhere else. The isolinear feet, the upright, stiff attitude of the bodies are alike, as is the technique in which the sculptures are worked. It should be noted, however, that the bodies are not sculptured with parallel sides but with bodies tapering upwards towards the hips and rather narrow (Pls. CLXXXVIII). In some cases the shape of the body and the hips are indicated below the dress (Pl. CLXXXVIII, 6). The monotonous arrangement of the arms in Style I is here sometimes somewhat altered as on the lyre-player, Pl. CLXXXVIII, 7. The most typical varieties as to this style is, however, noted, on the heads and the faces, which in this group are comparatively frequent. The female head, Pl. CLXXXVII, 3, evidently continues the tradition from Style I, though we note considerable and significant changes. In comparison with the head, Pl. CLXXXV, it is very much conventionalized. The neck is much nar-

rower, the face peculiarly oval in shape, the lips somewhat protruding, and the eyes sculptured in a less complicated way. The head-dress or veil of the previous style is here substituted by very much conventionalized curls which end in small coils. The head, Pl. CLXXXVII, 4, gives the impression of a thinner structure of the face, partly owing to the fact that the whole back of the head is missing. The way in which the mouth is sculptured on this head seems to be characteristic of the style. The lips are comparatively thin and somewhat protruding. The corners of the mouth are very slightly heightened while all the parts around the mouth are gently curved, but there is no sign of a smile. The eyes, too, of this head are characteristic of the style. The eye-balls are almond-shaped, the lids and brows gently curved and sculptured in a simpler way than in Style I. The powerful, female head, Pl. CLXXXVIII, 4 seems to represent a somewhat different type, though the damage to the face prohibits a close determination. The forehead is very sloping as on the small statuette, Pl. CLXXXVIII, 1, and the eye-balls seem to have been somewhat more prominent. The minor head, Pl. CLXXXVIII, 2, is of generally the same type, inferior in workmanship. The head, Pl. CLXXXVIII, 3, is interesting as it clearly shows the tradition from Style I, and at the same time displays rather advanced features of Style II. It can in this respect be compared with the head, Pl. CLXXXVII, 4. Both show many striking similarities, in contrast to the head, Pl. CLXXXVII, 3 with its rounded lips and heavy chin. This contrast seems to indicate that one may have to reckon with two sources of influence during this period. As to the jewellery noticed on sculptures of this style we note some of the same kinds as in Style I. The ear-decorations are there as the necklaces composed of biconical beads. The nature of the narrow necklace on the head, Pl. CLXXXVII, 3, may be difficult to determine. Apparently it is composed of rows of small beads.

Style III.

This style is represented by a very important monument, the colossal head, Pl. CLXXXIX, 1, outstanding among all Cypriote sculpture on account of its large size and perfection. In this head we meet with an entirely different style and there is no difficulty in determining whence the new style has been inspired. The head is so closely related to Egyptian sculpture that it at the first glance seems to have been imported from that country. The Egyptian traits are not restricted to the typical head-dress but they are characteristic of the whole outline of the head, as well as of the details, and the special treatment of the surface of the limestone, which has been carefully finished by means of polishing. This head is extremely important for the understanding of the further development of Cypriote sculpture as it constitutes one of the few heads preserved which show a comparatively pure Egyptian style, still unaffected by any kind of local transformations. The outline of the head is well defined, the neck short and powerful. The mouth is comparatively small with small angles at the corners, which are somewhat arched. The chin is well accentuated as on most Egyptian sculpture. The nose is short and broad while the eyes, placed far apart from each other are carefully and realistically sculptured with gently curved upper lids and brows. —

Possibly the head was sculptured by an Egyptian artist who worked in Cyprus or by a Cypriote who knew entirely from studies in Egypt the technique of that country. As the stone is the same one as is used for most of the other Arsos sculptures there is no doubt that the head must be of Cypriote origin.

Style IV.

Judging by the very few sculptures worked in the pure Egyptian style, this has not lasted for a long period in Cyprus. Style IV indicates how the style was altered and transformed gradually according to the local Cypriote character. As to this style there are thus two elements distinguishable, 1. the features of the original Cypriote style (Styles I—II) and 2. the new influence from Egyptian sculpture (Style III). On examining the sculptures ascribed to Style IV these elements are easily recognized. The head, Pl. CLXXXIX, 2, 3, to a certain degree reminiscent of the large head of Style III, is a typical example of this hybrid style. The outline of the face, the shape of the eyes and the hair indicates that the head is influenced by sculptures like Pl. CLXXXIX, 1. On the other hand the direct tradition from Style II, recognizable in the way of sculpturing the eyes, the shape of the ear-pendants, and the necklace, etc. The direct tradition from the earlier Cypriote styles is also noted in a series of minor female sculptures ascribed to this group (Pl. CXC, 1—8). Though characterized by a rather poor workmanship they can be classified on account of their typical hybrid features. The general attitude reminds one of Style II but the elaborate disposition of the arms indicates a more advanced development. Thus the arms on the statuette, Pl. CXC, 5—6 are partly sculptured free from the body. The attempt at sculpturing the backs of the figures, may on the other hand be explained as an influence from the Egyptian-looking sculptures of Style III. The way in which the figures keep their votive offerings is more or less the same as in the previous styles. Some varieties are, however, noted. The small figurine, Pl. CXC, 1—3, has its right forearm comparatively high, while the well proportioned statuette, Pl. CXC, 5—6, holds its small buck with both arms.

Style V.

This style is represented only by a few sculptures in the Arsos series, but the style is well exemplified by numerous finds from other sites (Kition, Vouni, Mersinaki, etc.). Again we meet with an influence from abroad. The smiling faces, the head-dresses and the drapery of the sculptures, etc. show clearly that the inspiring source this time lies in the Ionic regions of the Greek world. The Arsos series, like the sculptures from the other places show clearly that this Ionic influence was very strong. In the beginning it caused a very marked change of the previous development. The attitude of the small statuette, Pl. CXCI, 3, constitutes a very marked break with the attitudes described above. The Ionic *kore*-type is introduced in Cypriote sculpture in a comparatively advanced form, and without any preceding symptoms. The same can be said of the type of the heads, displaying Ionic traits. The large head, Pl. CXCI, 1—2, shows the earliest features. Though the face is badly damaged it is possible

to determine the head fairly accurately. The neck is short and powerful, the face rather triangular in shape with a broad forehead. The eyes, provided with carefully sculptured lids and brows in relief, are set somewhat obliquely. It must be supposed that the mouth was smiling. The treatment of the hair is also typical. It is combed backwards and falls down in detailed curls on either side of the breast. Above the forehead is a row of neat, minor curls. The jewellery is different from what we have seen on the previous sculptures. The disc-shaped ear-pendant, and the narrow necklace provided with a small pendant are both found on the Ionic sculptures of Greece. The diadem, too, belongs to the same cultural region.

The heads, Pl. CXC, 9—10, may represent a somewhat more advanced stage of the sculptures ascribed to this group. The eyes are not so oblique as in the previous case and the triangular shape of the faces is not so pronounced. The coiffure is typical for a more advanced stage of the Ionic sculpture. The hair is parted in the middle and gathered up into a hair-net on the nape of the neck.

The sculptures of this style correspond precisely to the earliest sculptures at Vouni and Mersinaki and to Style II in Kition, p. 56.

Style VI.

The fresh Ionic influence, represented by the sculptures of Style V, very soon faded and was absorbed by the Cypriote sculpture. This process can be studied on the sculptures of Style VI. The typical characteristics, predominant in the previous style, begin to vanish gradually. The bodies and the draperies still remind one of the archaic Ionic sculptures, but in the heads and particularly the faces, the differences are easily recognized. The faces are no longer triangular in shape, the powerful, archaic smile has faded into a rather faint smile, the eyes are not placed obliquely and are often stiff and conventionalized. Furthermore, the backs of the heads are neglected, not completed, as was the rule in the previous style. The fine, female head, Pl. CXCI, 4—5, may be picked out as a typical example of this group. The neck is short and thick, the face oval in shape with prominent chin, straight brow- and nose-line; the mouth is smiling with small, protruding lips. The smile is well accentuated but not of the vigorous expression which characterizes the sculptures of Style V. The face is framed by arched rows of curls, on which a heavy crown or diadem is placed. This is of the same type as on the head No 17 from Vouni (Pls. XLVIII; XLIX, 1—2) where it appears on a sculpture of earlier date. In Arsos it is found on sculptures during a comparatively long period. Curiously enough a diadem of this type has never been found in metal. The large ear-pendants on the head, Pl. CXCI, 4—5, are of the same type as on the earliest sculptures of Style I, and may therefore be regarded as a typical Cypriote jewel. The minor heads of this group (Pl. CXCI, 7—8) are of the same general type. The oval face with rather full cheeks, the clear, though somewhat faded smile and the way of sculpturing the eyes are characteristics which establish their places in the series.

Style VII.

The development which has been suggested above is continued in the next style and we note exactly the same development as has been demonstrated as regards the sculpture series from Vouni, Mersinaki, and Kition. The archaic expression and smile are but faintly reflected in this style. And, on the other hand, the traditional, local Cypriote characteristics are increasing. The faces display a typical stiff expression. The way of sculpturing the eyes is very much alike on all the heads of this group; they are elliptical and provided with sharp-ridged, stiff lids. The bearded head, Pl. CXCII, 1—2, is remarkable as it constitutes the earliest male head of large size in the whole series. The small head, Pl. CXCI, 8, ascribed to Style VI is most likely a male head, too, but as regards the rest of the sculptures described above there is no male ones. From now onwards, however, male sculptures are found in the series, though not very common. If the artists who worked in this style were not capable of giving the faces of the sculptures a new and characteristic expression, they were more interested in the details, especially the attributes, such as the diadems on the heads, the jewellery, etc. Evidently they laid stress upon the meticulous and detailed treatment of the curls, noticeable on the male head, Pl. CXCII, 1—2, as well as on the female heads, Pls. CXCII, 3—4; CXCIII, 1—2. The latter two heads wear most complicated crowns or diadems of a more advanced shape than those on the Vouni head, No. 17, Pls. XLVIII, XLIX, 1—2, and the Arsos head, Pl. CXCI, 4—5. The crown on Pl. CXCII, 3—4, is composed of sphinxes alternating with three rosettes placed above each other. Above the frieze are large lotus flowers alternating with buds. The other crown, on Pl. CXCIII, 1—2, is of a similar type, though not so complicated. Lotus ornaments are alternating with pairs of rosettes; the crown is finished with a wavy band. The peculiar Cypriote ear-pendants known from the earlier styles are seen on both these heads. The male head, Pl. CXCII, 1—2, too, is characterized by a complicated coiffure. Its face can be pointed out as one very typical for this style. Pl. CXCIII, 5, represents a small female statuette. Her attitude is very simple, strictly frontal, isolinear feet, arms along sides, and the head looking straight forward. The wide necklace with large pendants hanging across the breast is a type which appears here for the first time in the Arsos series. The type will be of a great significance for the future sculpture of Cyprus.

The sculptures referred to this group are of a type which is very well represented in other localities. As to the series from Vouni and Mersinaki they correspond most closely to those of Style III from these places (pp. 267 and 381). The sculptures from Kition of Style IV (p. 59) seem not to be so closely related to this part of the Arsos series but that may be explained by the fact that comparatively few sculptures of larger size were found in Kition. A great number of sculptures in other collections must be ascribed to this group (cf. Vol. IV).

Style VIII.

The further development of this kind of Cypriote sculptures has been traced in Vouni and Mersinaki as well as in Kition. In these places a further degeneration of the previous

style is very clear. The archaic smile disappears entirely from the faces, the proportions of the heads and the figures are very far from the real ones, all the details, even as regards the heads, are much neglected and the types are standardized and repeated without any attempt at changing them until the pure Hellenistic styles come like a fresh wind causing an entirely new direction of the development. This has been demonstrated in the sculpture series from Mersinaki and Soli (pp. 383 and 524 ff.; cf. Westholm, *The Temples of Soli*, Stockholm 1936, p. 184 ff.).

The same development is noted as to the Arsos sculptures, too, though, of course, the stratigraphical evidence is missing here. Some of these very retarded and degenerate sculptures, corresponding to Style IV in Mersinaki and Vouni, belong to the series from Arsos, but here, we also find some others of quite another, better quality. As to the chronology they must be placed earlier than the new, Hellenistic style, mentioned above. This indicates that, in Arsos, the fresh Greek influence came somewhat earlier than on other places, and that the degenerate style was paralleled by a highly developed Classical style. This may also explain why so few of the degenerate sculptures from this period were found in Arsos. The conditions may be compared with the two parallel series of sculptures in limestone and terracotta, which have been described as regards Mersinaki, p. 382 ff.

The head, Pls. CXCIV, CXCV, holds a more or less unique position among the Cypriote sculpture both as regards its style and the exquisite technique in which it is worked. The outline of the face is well marked and all its details are distinctly sculptured in a way which reveals the great anatomical knowledge of the artist. The powerful, energetic expression of the face, noticeable especially on the profile (Pl. CXCV, 1) indicates that the head most likely is a portrait. The features of the face make one think of a character like Axiothea, the queen of Nikokreon of Salamis, who as the last descendant of the Teucrian dynasty, preferred to kill her children and herself and to set fire to the royal palace rather than fall into the hands of the army of Ptolemy Soter.

In comparison with this exquisite head, the others of this group do not reach the same high standard. It is true that the female head, Pl. CXCVI, 4, is one of the very best specimens of sculptures from this period. The expression seems also to indicate that it is a portrait. The face is very well outlined and the peculiar shape of the eyes with straight lower lids imparts to the head a very characteristic expression. This head may be dated to the end of the series of this group, judging by the coiffure, which, as far as can be seen, was arranged as "melon rolls". The heads, Pl. CXCVI, 1—3, are very much alike. The coiffure is exactly the same as on Pls. CXCIV, CXCV, but the faces display some stiff traits, noticeable especially in the treatment of the eyes.

The frontal attitude, the symmetry and other features characteristic of this style place the sculptures in an earlier period than the following sculptures which are definitely marked by a clear influence from Greek Hellenistic sculpture styles.

Style IX.

It seems to be difficult to associate directly the sculptures of the previous style with those of Style IX. They are all much dependent on Greek influence but they represent two different epochs. Style VIII shows the Greek influence before the typical Hellenistic features are developed while Style IX displays a rather advanced stage of the Hellenistic influence. There are no examples of the earlier Cypro-Hellenistic sculptures in the series from Arsos such as we know them from Mersinaki and Soli. The period of Philadelphus seems not to be represented. The sculptures of Style IX correspond to the Alexandrine sculpture during the later part of the third century, and this may also be the date of the Arsos sculptures in question.

Three male heads are outstanding (Pl. CXCVII), which all may be portraits of Ptolemaic potentates. Two of them, Pl. CXCVII, 3, 4, must be portraits of the same person while, Pl. CXCVII, 1—2 differ somewhat as to the type of the faces, which appear very powerful, with a determined mouth, and wide forehead. The way of sculpturing the hair is peculiar. In contrast to the realism expressed in the face, the hair is characterized by a certain conventionalism. The curls are not sculptured in the ordinary Hellenistic way with plastic, three-dimensional details, but the way of indicating the curls is more in the nature of design on the surface of the head. All prominent parts are avoided, the various details of the curls obtained by means of mere incisions. The treatment of the eyes is also noticeable. The eyeballs are elliptical in shape and — as usual on Cypriote stone sculpture — there are no incised irises. The upper lids are arched and continued just a trifle below the lower lids. Exactly the same detail is seen on the heads, Pl. CXCVII, 3 and 4, and on these we recognize the same way of sculpturing the hair. On the other hand, the faces display some varieties which are worth noticing. The energetic expression which is characteristic of the head, Pl. CXCVII, 1—2 is absent here. The cheeks and the chin are full and slack and the outline of the lower part of the face is thus quite different. On the forehead, a characteristic, horizontal wrinkle is found on both heads just below the front-hair. — All the heads are turned slightly to one side, just enough to show that they are not sculptured in accordance with the frontal or symmetrical principle, like the heads described above.

On turning to the female heads, of which several exist, we distinguish the heads of more or less pure Hellenistic style from those characterized by local features going back to an earlier sculptural tradition of the island. It may be difficult to determine whether the sculptures of this group are real portraits or if they represent a mere type of face or head, characteristic of a certain period. As to the heads on which the Hellenistic traits are paramount, one feels inclined to suppose that they constitute actual portraits. But the heads of the local style seem not to be portraits except as can be supposed with reference to the votary sculptures of the Cypro-Archaic styles, viz., the general type of head is portrayed, but without any demands of exact likeness or detailed portraiture.

The head, Pl. CXCVIII, 1—2, is the best example of the local tradition during this period. The face is rather plump, placed on a short, thick neck. The nose is straight and almost vertical as on the decadent sculptures of the previous style. The mouth is small and straight.

The soft treatment of the brows and eyes indicate an influence from the Hellenistic sculptures. The hair arranged in a very complicated way as on certain Alexandrine terracottas, is gathered up by a fillet. The whole is crowned by a diadem of pointed upright leaves and rosettes. On the back of the head a flat square pillar reminds one of the arrangement on Egyptian sculptures. The head displays a very strange mixture of Cypriote and Alexandrine features.

There is also a small group of minor heads which are worked in more or less pure local style (Pl. CC, 5—7). They all show a very developed decadence in the style which make it almost impossible to date them more precisely. The head, Pl. CC, 7, must have been influenced by sculptures of the same type as Pl. CC, 8. Evidently the crown is the same, and the way of sculpturing the nose and the mouth indicate the same influence. The head, Pl. CC, 6, should definitely be connected with sculptures of Style IV in Mersinaki, and still later types, while Pl. CC, 5, constitutes an interesting example of a head on which the decadence is brought so far that practically no details of the face have been sculptured. Possibly the eyes were indicated by means of paint.

The plump, oval face with vertical nose and sloping chin is, too, characteristic of the rest of the heads of this group. This holds good especially as to the larger heads on which the Greek-Ptolemaic influence is very clear. The head, Pl. CXCVIII, 3—4, is typical in this respect. The face is almost ovoid, if compared with the head, Pls. CXCIV, CXCIV, which was ascribed to the previous style. The chin is slightly pointed and its under-side slopes somewhat. The lips are protruding; the nose is short and straight; the eyes comparatively small and provided with lids and heavy eyebrows, the latter worked in a peculiar stiff way. The coiffure of this head seems to represent a development of the head-dress of the female sculptures of the previous style. The side-curles are very much conventionalized while the parted hair on the middle of the crown is simply indicated like short, parallel incisions. The ribbon in the hair is hardly distinguishable. A comparison between the two heads, Pls. CXCIV, CXCIV and Pl. CXCVIII, 3—4, thus offer very significant features characteristic of the two styles.

The three heads, Pl. CXCIX, 5—7, show another type of this style, though the typical characteristics are not so predominant. The ovoid shape of the face is recognized, like the shape of the chin and the nose. The mouth, however, shows a very characteristic wavy line with lowered corners. The hair is parted in the middle and indicated by means of rather low incisions. The large heads of this type may have influenced a series of minor heads, some of which are pictured on Pl. CXCIX, 1—4. These are of a more local type but some traits connect them definitely with the series described above. The way of sculpturing the mouth is especially significant in this respect. We note the same wavy line between the lips, etc. The head, Pl. CXCIX, 2 is provided with the typical "melon roll" coiffure characteristic of most of the Ptolemaic female portraits. The same kind of coiffure is found on two other heads in the Arsos series (Pl. CC, 1—2 and 3—4). As to the possibility of identifying the Cypro-Hellenistic sculptures with Ptolemaic portraits, see Westholm, *The Temples of Soli*, p. 190. The two heads in question seem to represent the same lady or the same general type

of face but it is impossible to determine them any further. A technically interesting detail may be pointed out which occurs on both heads. The hair is gathered on the back of the head into a knot. This is continued down the neck in shape of a square support like those found on Egyptian sculptures. There may be no doubt as to the Alexandrine origine of such a detail on the Cypro-Hellenistic sculptures.

In comparison with the great amount of heads, it is surprising how few bodies of limestone sculptures were found in Arsos. As to the Cypro-Hellenistic sculptures only a few bodies were preserved more or less completely. To them should be added a series of fragments of large female sculptures but in no case could they be fitted to any of the heads in the series. Under such conditions it is very difficult to determine to which of the Cypro-Hellenistic styles between which the heads have been distributed, the bodies should be ascribed. Evidently all the sculptures to which these fragments belong, were draped in a long tunic and a comparatively short himation which hangs on the head to just below the knees, leaving a part of the breast uncovered. As a rule, the tunic is gathered in by a ribbon just below the breast. In other cases the ribbon runs around and below the breast and is tied into a knot between the breasts. The way of sculpturing the drapery varies considerably, especially as to the tunic. In most cases the tunic is folded vertically in very fine and somewhat rippled folds, apparently indicating a very soft woollen material (Pl. CCI, 5, 6, 9). Others are provided with very stiff folds in the tunic, such as on Pl. CCI, 7. The various kinds of jewels are noticeable. Some of the sculptures have a simple, narrow necklace with a knot in front (Pl. CCI, 1, 5, 7) while others are provided with wide strips from which rows of pendants are suspended (Pl. CCI, 4, 6, 8), of the same kind as on sculptures of earlier styles. The large statue, Pl. CCI, 1, is provided with a twisted bracelet.

The sculpture, Pl. CCI, 8, is worth noticing. Possibly it should be ascribed to this group as it evidently had the himation hanging over the head. (The fold of the himation comes down on the left side). The necklaces are also of the same kind as on Pl. CCI, 4. The drapery is worn away entirely. On the right side, two plaits or curls of the long hair come down like on the Greek-Archaic *kore*-statues. The curls are very neatly rippled and the way in which this is done reminds one undeniably of the archaic sculptures, and most likely we here see an intentional striving towards archaism.

TERRACOTTA SCULPTURES

The classification of the terracottas must be made independently of the limestone sculpture. It is true that in some cases the styles are very much alike and that some terracottas could be compared directly with some of the limestone sculptures but when classifying the whole series it becomes evident that there exists only an occasional correspondence between the two series in stone and terracotta. First of all, there are no terracottas found corresponding to the later limestone groups, viz., the Cypro-Classic and Cypro-Hellenistic styles. Whether this is due to the terracottas during those latter periods being located to the western portions of the island exclusively or if it is a mere chance in Arsos remains uncertain. It is a fact, however, that by far the bulk of the terracotta sculptures from the later periods

have been found in western Cyprus while only a few of them originate from the eastern part of the island. Thanks only to the wonderful series of early terracotta sculptures found in the temenos at Ajia Irini, where they could be classified in accordance with the stratification on the site, the terracotta styles of Arsos can be safely distinguished, and placed chronologically into a scheme.

Hand-made statuettes.

This group is represented by a few sculptures which are made in "snow-man" technique. They are extremely primitive and should be regarded as mere idols, corresponding fairly well to Type 6 among the terracottas from Ajia Irini (cf. Vol. II, p. 787). The queer statuette, Pl. CCII, 1—2, is provided with a trunk-shaped body on which the female breasts are placed like buttons. The eyes and the dress are indicated by means of paint. Pl. CCII, 3 represents a seated woman very crude and carelessly made in "snow-man" technique. The throne is painted with vertical black and red lines. Unfortunately the head is broken and missing.

Moulded male statuettes.

The sculptures ascribed to this group correspond to Type 8 of the Ajia Irini series. They are made in moulds and unfinished on the back. One of them (Pl. CCII, 5) is bearded while the other one has no sculptured beard, though the same may have been indicated by means of paint (Pl. CCII, 4). The male statuettes have isolinear feet, straight body, right arm folded across the breast. They wear a long chiton and a himation over both shoulders. The beard on Pl. CCII, 5, is arranged in vertical screw-curly rather conventionalized in shape.

Moulded female statuettes.

Pl. CCII, 9, shows the simplest type, having isolinear feet, the arms along the sides, and strictly frontal attitude. The head is very small and provided with long hair on either side of the neck. The dress is peculiar. Over a long tunic hangs a half-length himation with a fringed, arched edge at the hips. At the breast there is a square piece cut out of the himation. The female breasts are protruding below the dress. The statuette, Pl. CCII, 6, holds a tambourine over the breast. The dress seems to be more or less like the previous one. The two statuettes, Pl. CCII, 7 and 8, are interesting. They are both of similar type, though not made in the same mould, and show a woman suckling a child of a rather large size. The woman is upright and looking straight forward. She wears a long tunic and over this, a short himation. The shape of the head (Pl. CCII, 8) reminds one very much of the limestone sculptures of Style III (Pl. CLXXXIX, 2), with a broad face, the hair combed behind the ears and coming down on the breast.

The head, Pl. CCII, 10—11, which is of a somewhat larger size than the rest, could definitely be placed in the same group as the Ajia Irini sculptures of Style VI. We note the same shape of the face, the broad, straight mouth, the large semicircular eyes

with heavy, incised eyebrows. The coiffure of some of the female statuettes are also exactly the same on the sculptures from Arsos and from Ajia Irini. Of course it may be possible to distinguish various types among the sculptures ascribed to this group and typologically earlier and later specimens, but as there is no stratigraphical support for such a division they are all here gathered under one heading and described in accordance with their attitude.

All the sculptures are made in moulds but some of them have been worked over subsequently. One series of the figurines represent entirely naked women or possibly wearing a very thin tunic below which all the details of the bodies are visible. In cases when no paint is preserved it is practically impossible to distinguish the tunic. In a few cases the border of the tunic seems to be indicated by means of black or red paint (Pl. CCIII, 7). In other cases (Pl. CCIII, 8—9) the upper edge of the tunic is marked like a square piece cut out over the breast. As to the figurines wearing a more complicated dress they are all represented in the same attitude, with isolar feet, frontal position, with right arm folded over the breast, the hand holding some object, while the left arm is placed along the side. The fine statuette Pl. CCIII, 3—4, wears a plain tunic, rather wide, but leaving all the details of the body visible. The jewels are of the same kind as on the limestone sculptures of Style I. The string necklace with the large circular disc is there, as is the necklace similar to that on Pl. CCV. The uppermost necklace, too, may be compared with those on the sculptures of Style I, as can the large ear-pendants. The front-hair is arranged in a heavy torus above the forehead, while other parts of the hair fall down on the shoulders. This sculpture shows the purest form of the type. The statuette, Pls. CCII, 12 and CCIII, 1—2, is very similar but constitutes a somewhat more advanced type. The dress is different. The tunic is folded vertically below the plain overfold. Other varieties of the type are visible on Pl. CCIII, 5 and 6. These moulds are rather worn so that the details are distinguished with difficulty. The queer wild expression of the latter statuette, and its large eyes with arched eyebrows and the somewhat smiling mouth are all rare features on the Arsos terracottas.

The series of female terracottas which give the impression of being naked display some varieties as to the attitudes (Pl. CCIII, 7—12). They are all of the frontal position but the arms are held in various attitudes. Pl. CCIII, 8—9 has the arms along the sides; Pl. CCIII, 7, has the right arm folded across the body holding a bowl (?) while Pl. CCIII, 10—12, hold the breast or point to the genitalia. This gesture recurs on a great many fragments from Arsos, and evidently the gesture must be connected with the cult in some way. The statuettes Pl. CCIII, 8—12 have the same kind of coiffure: the hair arranged in several thin plaits over the head some of them falling down over the shoulders.

MINOR OBJECTS

Bronze.

Spear-head (Pl. CCIV, 1).

This is leaf-shaped and provided with mid-rib and socket.

Chisel (Pl. CCIV, 2—3).

Two chisels were found of the same general type, straight, almost parallel sides and somewhat wider at the edge.

Needle (Pl. CCIV, 4—5).

Two needles were found of exactly the same type, rather thick and provided with a rather large eyelet.

Bracelet (Pl. CCIV, 6).

The bracelet is circular in section and provided with slightly flattened, overlapping ends.

Finger-ring (Pl. CCIV, 7—9).

The rings are plain and circular in section.

Bowl (Pl. CCIV, 10, 11).

The two bowls are shallow with rounded bottom.

Silver.

Earring (Pl. CCIV, 13—16).

Four different types are distinguished; 1. plain circular, 2. spiral, circular in section, 3. leech-shaped, 4. leech-shaped with a pendant attached to it.

Gold.

Bead (Pl. CCIV, 18—20).

The beads are of various shapes, 1. flat circular, 2. date-shaped, 3. cylindrical with bent-up edges.

Earring (Pl. CCIV, 22).

Only a tiny twisted earring was found.

Mounting (Pl. CCIV, 17, 21).

Circular mounting decorated with an impressed rosette-ornament.

Necklace (Pl. CCV 2—4).

The two necklaces are rather alike but it is not difficult to see that the minor one is a comparatively poor copy of the large one. This is composed of 40 beads and one pendant. The beads are biconical with soldered globules round the string-hole and radiating rows of globules to the angle-point which is encircled by three rows of globules. The beads are of equal size. The pendant consists of a cylindrical piece of agate with golden mountings below and above, consisting of friezes of triangles and lozenges composed of small, soldered

globules. The pendant was fixed to the string by means of a horizontal, cylindrical, hollow mounting decorated with soldered globules. On this are fixed two *uraei* with the crowns of Upper and Lower Egypt on either side of a bee, the latter with plain wings but with eyes of soldered globules. The whole necklace is characterized by a technically very high quality. — The second necklace consists of 19 biconical ribbed beads with somewhat moulded edge and a pendant in the middle consisting of an agate bead with an incised line near the lower end. The pendant is attached to the string by means of a string-hole cylinder on a socket of thin gold sheet. The gold is white, probably mixed with silver.

B o w l (Pl. CCV, 1).

The gold bowl is shallow, with rounded bottom and plain rim.

F a i e n c e.

B e a d (Pl. CCIV, 12).

The faience beads are all of the same general type rather like the gold beads in the necklaces described above. They are more or less biconical, ribbed and provided with large string-holes.

G l y p t i c s (CCIV, 23).

The series of scarabs found in the excavations at Arsos have been examined by Dr. Max Pieper in Berlin whose paper is printed here below in the original language.

- a. Unten zerstörter Skarabäus, Unterseite: *zweimal* Tronname Thutmosis III, darüber der Titel *nswit bjti* "König von Ober- und Unterägypten". Auf Skarabäen ist dieser Titel ausserordentlich selten, erst in libyscher Zeit (um 900 v. Chr.) findet er sich häufiger. In diese Zeit wird auch das fragliche Stück gehören. An der ägyptischen Herkunft ist kein Zweifel.
- b. Skarabäus oder Gemme aus dunklem Stein, Unterseite: Pferd. Ägyptische Herkunft zweifelhaft.
- c. Skarabäus im Stil des Mittleren Reiches (1800 v. Chr.): 2 C-Spiralen in einander eingehängt, rechts und links 4 Zeichen *sa*-"Schutz".
- d. Skarabäus oder Gemme aus dunklem Stein, Unterseite: Falkengreif, geflügelt. Spät, wenn nicht bereits griechisch.
- e. Skarabäus der Spätzeit (kann auch bereits saitisch, d. h. 7/6. Jahrh. v. Chr. sein). Unterseite: eine Katze, daneben Sonnenscheibe, wie es sich auf Amuletten der Spätzeit häufig findet, s. Newberry, *Scarabs*, T. LXII, No. 17, 21.
Das Zeichen neben der Katze macht Schwierigkeiten. Es sieht wie ein gezacktes Blatt oder wie der Zweig eines Baumes aus. Erwarten würde man ein Auge, oder einen Teil davon (letzteres s. Newberry, a. a. O. XLII, 17), denn nach allem, was sich feststellen lässt, sind diese Katzensteine, die häufig gleichzeitig ein Auge

- enthalten, Amulette gegen den bösen Blick. Weshalb dazu Darstellungen der Katze genommen werden, ist naheliegend.
- f. Skarabäus, Unterseite: 4 Zeichen, die weisse Krone, der Falke, ein Krug das Zeichen für Palast. Ein ähnliches Stück Ajia Irini, No. 2236 (Vol. II, Pl. CCXLV, 33).
 - g. Skarabäus, Unterseite: 3 Figuren, Mann mit Nilpferd und Eidechse. Diese Skarabäen waren Amulette gegen Krankheiten, es hat sich bisher noch nicht feststellen lassen, gegen welche. Heilmittel gegen Krankheiten sind die Skarabäen eben so häufig wie ihre letzten Ausläufer, die Abraxasgemmen, die gelegentlich als Heilmittel gegen Blutstillung bezeichnet werden. Etwa um 1200—1000 v. Chr.
 - h. Länglicher Skarabäus, an der einen Seite bestossen, Unterseite: Mann mit weisser Krone und langem Scepter, dahinter im Königsring Tronname Thutmosis III. Das Stück gehört der Spätzeit (1000—700 v. Chr.) an. An seiner ägyptischen Herkunft ist wohl nicht zu zweifeln.
 - i. Skarabäus oder Gemme aus dunklem Stein, was auf der Unterseite steht ist schwer zu bestimmen. Hinter 3 Kugeln etwas, was an einen Skorpion erinnert, aber mit doppeltem Schwanz. Vorderasiatische Technik.
 - j. Skarabäus oder Gemme aus dunklem Stein. Auf der Unterseite eine eigenartige Scene. Vorn ein Hirsch mit starkem Geweih. Dahinter ein Kentaur oder genauer ein auf einem geflügelten Greife sitzender bärtiger Mann. Zweifellos kyprische Arbeit.
 - k. Skarabäus, Unterseite: Oben Sphinx, darunter unerkennbare Zeichen. Das Stück erinnert an die sogen. Neujahrsskarabäen.
 - l. Skarabäus oder Gemme aus dunklem Stein, Unterseite: Pferd. Was darüber steht, sieht wie ein Vogel mit ausgebreiteten Flügeln aus.

In addition to the series of sculptures found at Arsos by Mr. Markides, three heads will be published which all seem to fit into the series very well. The heads are now in Stockholm. One of them (Pl. CCVIII) was purchased in the village Arsos, and, therefore, its origin seems to be ascertained. The two other heads (Pls. CCVI, CCVII) were presented to the Expedition by the late Mr. Luke Pierides. There is no certain record of whence they originate.

The question where these heads should be placed in relation to the series described above will be answered by an analysis of the heads. The bearded head, Pl. CCVI, with its square proportions of the face, small, protruding mouth and semicircular eyes with plastically indicated eyebrows resembles some of the heads of Style II of the Arsos series. As all the Arsos sculptures of this style are female it is impossible to associate the head more closely with the Arsos series. The short beard, and other characteristics, however, connect the head definitely with Style III in the Ajia Irini series of terracotta sculptures (cf. Vol. II, Pls. CCIV—CCIX). This kind of beard distinctly marked in relation to the cheeks is very characteristic of a certain group of Cypro-Achaic sculptures, and as the whole structure of the face, Pl. CCVI, tallies with the sculptures mentioned here, it is right to coordinate

the head with the sculptures of Style II in the Arsos series and Style III in the terracott. series from Ajia Irini.

The head, Pl. CCVII, is not so easily determined. Evidently it is very much influenced by the Egyptian sculptures of a kind similar to the large head on Pl. CLXXXIX. The mouth resembles very much the mouth on Pl. CCVI and the structure of the face is also rather the same though the chin is somewhat more pointed. The eyes are also made in the same way though the shape of them is not semicircular but elliptical. The simplified way in which the whole head is outlined and sculptured may point to an Egyptian origin of the style. On the other hand, the local Cypriote traits are undeniable. Technically the head is interesting as the surface had not been finished, so that one can see the traces of the artist's tools on the chin and the cheeks. All these features indicate that the head in style and technique approaches the Arsos sculptures of Style IV very closely, viz., the style which is strongly marked by the Egyptian influence, but shows at the same time that this style has been transformed considerably by the local Cypriote artists.

The fine head, Pl. CCVIII, found and purchased in the village Arsos displays quite other characteristics. Only on rare occasions is on Cypriote sculptures the Ionic expression so pure. In this respect the head is remarkable. The powerful Ionic-Archaic smile places the head definitely by the side of the sculptures of Style V in the Arsos series. The elaborately sculptured chin and cheeks, the somewhat obliquely set eyes with heavy upper lids are features which make the head stand out as a typical example of Ionic influence in Cyprus, while some other details, such as the small spiral-curly on the front-hair, etc., indicate the local Cypriote tradition. It is true that the same curls are common in Ionic sculptures, but they occur on some of the Cypriote styles already before the Ionic influence begins. As the sculptures of Style V are comparatively rare in Arsos, the head, Pl. CCVIII, constitutes a very important supplement to the series excavated by Mr. Markides.

A. W.











A P P E N D I X I

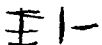

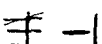
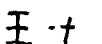
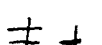
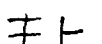

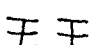
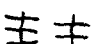
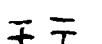
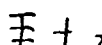

MORE CYPRO-MINOAN INSCRIPTIONS

On certain Mycenaean objects, mainly vases, originating from tombs in Enkomi and Idalion, excavated by the Swedish Cyprus Expedition, some inscriptions may be noted. The majority of these consists of one or a couple of signs which — as regards the vases — usually have, after the baking, been scratched on the handles with some pointed tool, or in some instances on the bottom of the vases.

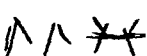
These signs belong to the Cypro-Minoan group which now is not unimportant. They are either identical with the later Cyprian syllabic script or identifiable with the same in spite of the gap of nearly five centuries which separate the two systems of script chronologically. On the other hand the Cypro-Minoan signs can be identified in accordance with purely Minoan characters belonging to Evans' Linear B and Linear A systems. The question of the relationship between Minoan script and Cyprian syllabic script, which has previously been suggested by Evans and Sundwall, was carried further by me; new investigations have confirmed my opinion that it is really possible to read the Cretan inscriptions in this way. As the Cypro-Minoan script forms a connecting link between the two, every addition to the previous material is certainly very welcome. Because, the later Cyprian syllabic signs represent a simplification of the Minoan ones in cases in which a confusion of types is impossible, a simplification which has developed in accordance with certain principles which are outside the scope of this paper. No doubt the change of material has been of a certain importance in this development. The varieties of technique when drawing in unbaked, soft clay, when scratching after baking, or when carving in stone, must necessarily lead to rather significant differences in the shapes of the characters.

The following list contains the new inscriptions:

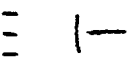
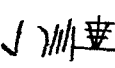
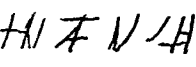
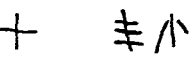
1.  *pa.* Enkomi, Tomb 18, Side-chamber, No. 59 (Cf. *Swed. Cyp. Exp.* I, p. 554 ff.). Jug (three-handled jar), painted on bottom.
2.  *pa.* *Ib.*, No. 77. Jug (three-handled jar), incised on handle. One handle is missing; probably this had another sign in accordance with other three-handled vases with inscriptions.
- 3 a.  *pa ta.* *Ib.*, No. 6. Pear-shaped amphora, incised on handles, one sign on each.
- 3 b.  *pa ta.* On the same, incised on bottom. (Fig. 319).
4.  *pa ta.* *Ib.*, No. 31. Pear-shaped jug (three-handled jar), incised on handles.
5.  *pa ta.* *Ib.*, No 48. Crater, incised on handles.
6.  *pa ta.* *Ib.*, No. 53. Stirrup-vase (false-necked jar), incised on handles.
7.  *pa ta.* *Ib.*, No. 58. Jug (three-handled jar), incised on two of the handles.
8.  *pa na.* *Ib.*, No. 5. Jug, incised on the handle, one sign on the top, one sign at the base with the upper parts of the signs facing each other.
9.  *pa na.* *Ib.*, No. 54. Stirrup-vase (false-necked jar), incised on handles. Both signs incised against the false-neck with the upper parts of the signs downwards on the handles.
10.  *pa na.* *Ib.*, No. 55. Stirrup-vase (false-necked jar), incised on handles, as on No. 9. (Figs. 316, 317).
11.  *pa na.* *Ib.*, No. 74. Jug, incised on handle, as on No. 8. (Fig. 320).
- 12 a.    *pa ta si — na.* *Ib.*, No. 47. Crater, incised 12 a on base-ring, 12 b on bottom. (Fig. 318).
- 12 b.  *i.*

13.  *ko to* (?) *Ib.*, No. 74. Jug, incised on base.
14.  *ko ko va. Ib.*, No. 57. Jug (three-handled jar), incised on the handles.
15.  *va. Ib.*, No. 272. Amphora, incised on base. The sign is a variety of the third sign in No. 14. (Fig. 321).
16.  *ku.* A sherd (handle found in Tomb 3).
17.  *ka to.* Tomb 11, No. 24. Jug (three-handled jar), incised on two of the handles. (Fig. 322).
18.  *lo.* *Ib.*, No. 115. Monochrome jug, two incised lines on handle, the sign at top of handle.
19.  *ta,* with a figure sign. Tomb 6, No. 77. Jug, Plain White Wheel-made Ware, incised on rim and handle (I have not seen the original which is in Cyprus).
20.  *sa . . la* (?). Tomb 7 A, No. 1. Jug, Plain White Wheel-made Ware, incised on handle. (Fig. 314).
21.  *a¹ to* (?) *sa la* (?). Idalion, No. 1416. Jug, Plain White Ware, incised on handle. (Fig. 315).
22.  *lo — pa ti.* *Ib.*, No. 1139. Spindle-whorl of steatite, biconical. First sign on one cone, the rest on the other cone.
23.  *pa ku.* *Ib.*, No. 1294 (*Swed. Cyp. Exp.*, Vol. II, Pl. CLXXXVI, 21). Cylinder of faience paste, inscribed signs.

In the following diagram the signs which are met with in the aforesaid inscriptions are compared with the corresponding signs of the Cypro-Classic syllabic script in accordance with the signs listed in Collitz-Bechtel, *Sammlung der griechischen Dialektinschriften* I; from the Mainland script, after Evans, *Palace of Minos*, IV, p. 745;¹ from Linear B and Linear A, after Evans, *op. cit.*, Figs. 666 and 659; and from the hieroglyphic-pictographic script, after Evans, *Scripta Minoa*, I, p. 232 f.

		C Y P R U S		THE GREEK MAINLAND	C R E T E		
		Class. syllabic	Cypro- Minoan	Late Helladic	Linear B	Linear A	Hiero- glyphic picto- graphic
1	pa	𐀀	𐀁	𐀁 Ti. 𐀁 Th.	44 𐀁 𐀁 𐀁	13 𐀁 𐀁 𐀁	128 𐀁 𐀁
2	ta	𐀂	𐀃	𐀃 Th. 𐀃 A.	58 𐀃	33 𐀃 𐀃	9 𐀃 𐀃
3	na	𐀄	𐀅	𐀅 Th. 𐀅 Th.	41 𐀅 𐀅 59 𐀅	47 𐀅 𐀅 𐀅	
4	si	𐀆 𐀆 𐀆	𐀇	𐀇 𐀇 Th. 𐀇 A.	9 𐀇 𐀇 𐀇	3 𐀇 𐀇 𐀇	20 𐀇 (?)
5	i	𐀈	𐀉	𐀉 A.	12 𐀈 𐀈		
6	ko	𐀊	𐀋 𐀋 𐀋	𐀋 𐀋 Ti. 𐀋 Th.		58 𐀋 𐀋	
7	to	𐀌 𐀌 𐀌	𐀍 𐀍 𐀍	𐀍 Ti.		64 𐀍 𐀍 63 𐀍	
8	va	𐀎 𐀎	𐀏 𐀏	𐀏 A. 𐀏 Th.	49 𐀏	24 𐀏 𐀏	
9	ku	𐀐 𐀐 𐀐	𐀑 𐀑	𐀑 A. 𐀑 Th. 𐀑 Ti.	21 𐀑 𐀑 𐀑	29 𐀑 𐀑 𐀑	36 𐀑 133 𐀑
10	ka	𐀒	𐀓			73 𐀓 𐀓	15 𐀓 𐀓
11	lo	𐀔	𐀕 𐀕	𐀕 Th. 𐀕 M.	25 𐀕	19 𐀕 𐀕	112 𐀕 𐀕 𐀕
12			𐀖 (?)				
13	sa	𐀗 𐀗 𐀗	𐀘 𐀘				
14			𐀙 (?)				
15	la	𐀚	𐀛		15 𐀛	37 𐀛 𐀛 𐀛	
16	a	𐀜 𐀜	𐀝		36 𐀝 𐀝 𐀝		
17			𐀞 (?)				
18	ti	𐀟	𐀠	𐀠 M. O. 𐀠 𐀠 Th.	17 𐀠 𐀠	23 𐀠 𐀠	13 𐀠 𐀠



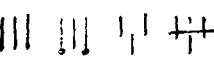
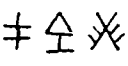





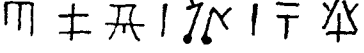

Diagram I. A. = Asine; M. = Mycenae; O. = Orchomenos; Th. = Thebes; Ti. = Tiryns.

The purpose of this diagram is to show the development of the signs referred to as far as possible from the pure pictographic script in Crete to the linear syllabic script in Cyprus. This is not the place to follow the transformation of each single sign which, with regard to the importance of the acrophone principle in the history of the development of script² will give valuable results also in order to enlarge our knowledge of the vocabulary of the Minoan language. I will only briefly mention one exemple, the sign No. 3 in the diagram with the phonetic quality *na*.

There seems to be no doubt that the sign No. 3 represents a column. As far as I know, no word for column beginning with the syllable *na* exists in the languages, which may have influenced Crete at the time in question. But there is a word in the Greek, $\nu\alpha\acute{\omicron}\zeta < \nu\alpha\sigma\phi\omicron\zeta$, which in my opinion should be taken into consideration, provided we work on the hypothesis "pars pro toto" (cf. the ox's head in the Phoenician alphabet in the meaning of *alef* = ox), which undoubtedly would be right. The etymology of the Greek word $\nu\alpha\acute{\omicron}\zeta$, which is associated with $\nu\alpha\acute{\iota}\omega < \nu\alpha\zeta\text{-}\iota\omega$ "reside, reside in" is not quite clear. Its original significance ought to be "dwelling" secondary "dwelling for a god, shrine, temple". In Classical Greek, too, $\nu\alpha\acute{\omicron}\zeta$ has a special significance "the inmost part of a temple, shrine containing the image of the god".³ It is well known that in the Minoan religion there were no dwellings, temples, erected for the gods — the gods lived with the kings — and therefore I suppose that $\nu\alpha\acute{\omicron}\zeta$ originally meant "palace" but when the kings later on were expelled, the gods alone resided in the $\nu\alpha\acute{\omicron}\zeta$. The importance of the column, especially in Knossos, and also in Mycenae and Tiryns, is well known. The circumstance that the column-sign never occurs among real pictographic signs, neither hieroglyphic nor pictographic, may be explained by the column being an architectural element without any important role at the time when that system was in use. Besides, the name Νάστης of the leader of the Carians (Il. II, 867) indicates the non-Indo-European origin of the word $\nu\alpha\acute{\omicron}\zeta$. It is met with later on, too, in Asia Minor (cf. Quintus Smyrnaeus, I, 281), and in favour of the same origin speaks the occurrence of the name-stem *na* in several native names in the same country.⁴ — The word $\nu\alpha\acute{\omicron}\zeta$, the original meaning of which is still associated with the column sign, has thus changed its significance in connexion with the transformation of the palace from being a dwelling for the king to a temple for the gods, a development well confirmed by archaeological researches.

Before proceeding to a determination of the significance of the signs we must briefly recapitulate other similar inscriptions from the Mycenaean period. Recently Mr. C. Schaeffer has made a compilation of similar signs, but only of those painted on the bottoms of Mycenaean vases, in his publication *Missions en Chypre, 1932–1935* (Paris 1936), p. 119 ff.; the list given by Sir Arthur Evans, *Minoan Script in Cyprus*,⁵ has proved to be incomplete. *Inter alia* a group of inscriptions is missing which are published by M. Markides.⁶ Their general character loosely resembles that of the signs published above. Eight of those are to be found on vases "from tombs of the Late Bronze Period, all of the plain white, sometimes coarse ware". They are jugs in those cases, where the shapes of the vases are determined, and originate from excavations conducted at

Skouriotissa and Katydhata near the north-west coast of Cyprus in 1915. To these are added two inscriptions from Arpera and one from Enkomi.⁷ The signs are "inscribed (probably incised), usually on the handles", sometimes on the body of the vases. As the publication in question is comparatively rare I include here drawings by M. Markides, but wish to point out that I have never had an opportunity to check them with the originals.

1.  *pa*. Skouriotissa, Tomb 11, No. 3. Jug, on handle.
- 2 a.  *pa*. *Ib.*, No. 17. Jug, on handle.
- 2 b.  figure sign 3, *ne ? ku*. Same, on shoulder.
3.  *pa ka ?* *Ib.*, No. 11. Jug, on handle.
4.  *ri*. *Ib.*, Tomb 42, No. 16. Jug, on handle.
5.  *la*. *Ib.*, Tomb 50, No. 20. Jug, on handle.
6.  *no la*. *Ib.*, Tomb 85. Fragment of a handle.
7.  figure sign 33. *Ib.*, Tomb 100, No. 12. Fragment of a jug, on handle.
8.  figure sign 40. *Ib.*, Tomb 101. Handle only.
9.  *ri pa si (?) |?| na?* Arpera, excavations 1914. Site A.
Fragment of pithos, Coarse Reddish Ware.
10.  *ku (?) ko*. *Ib.*, Site B. Fragment of handle, Plain White Ware.
11.  *po pa si ka ro*. Enkomi, excavations 1913. Fragment of a pithos,
Plain White Ware.⁸

Some other signs painted on the bases of vases are found in Schaeffer's list, p. 119 ff. Furthermore, in the Catalogue of Vases in the British Museum I:2 the following vases from Cyprus provided with inscriptions are included:















- C. 379  (*Car. ts.*) Marion, Tomb 2 or 16. Fragments of amphoid crater, incised handle.
- C. 391  (*Car. h'e. ?*) Kourion, Tomb 102. Crater, painted on bottom.
- C. 412  *lo.* Klavdia. Crater with two horizontal handles, painted on bottom.
- C. 430   *pa ?* Enkomi, Tomb 45. Pithoid jar (three-handled), incised on handles.
- C. 434   *su la.* Hala Sultan Tekké. Pithoid jar (three-handled), incised on handles.
- C. 477  *u.* Maroni, Tomb 5. Pithoid jar (three-handled), painted on bottom.
- C. 501   *ta ta.* Kourion, Tomb 50. Stirrup-vase (false-necked jar), incised on handles.
- C. 514  *pa.* Klavdia, Tomb 19. Stirrup-vase (false-necked jar), painted on bottom.
- C. 523   *ka ta.* Enkomi, Tomb 48. Stirrup-vase (false-necked jar), incised on handles.
- C. 555  *u.* Enkomi, Tomb 83. Squat globular jar, painted on bottom.



Fig. 314. Inscription (No. 20) on handle of amphora, Enkomi. T. 7 A, No. 1.

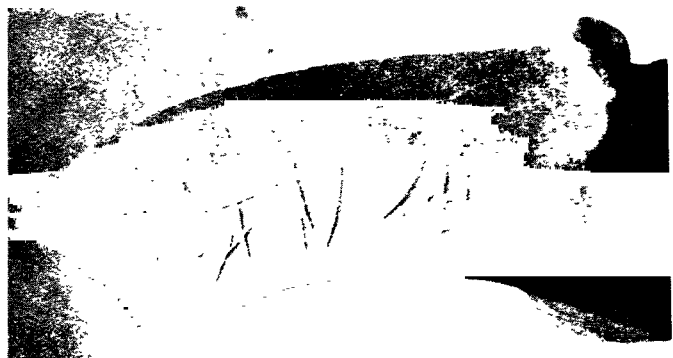

Fig. 315. Inscription (No. 21) on handle, Idalion No. 1416.

		C Y P R U S		THE GREEK MAINLAND	C R E T E		
		Class. syllabic	Cypro- Minoan	Late Helladic	Linear B	Linear A	Hiero- glyphic picto- graphic
1	pa	𐤑	𐤑𐤑		- Diagram I,1		
2	ne	𐤎𐤅 𐤎𐤆 𐤎𐤇	𐤎𐤅				
3			𐤎𐤆				
4	ku	𐤕𐤅 𐤕𐤆 𐤕𐤇	𐤕𐤅		- Diagram I,9		
5	ka	𐤕𐤁	𐤕𐤁 𐤕𐤂		- Diagram I,10		
6	ri	𐤕𐤓 𐤕𐤔	𐤕𐤓			11 𐤕𐤓	10 𐤕𐤓
7	ri (Carian)		𐤕𐤓 𐤕𐤔				
8	la	𐤕𐤁	𐤕𐤁		- Diagram I,15		
9	no	𐤕𐤆	𐤕𐤆	𐤕𐤁.			
10	si	𐤕𐤓 𐤕𐤔 𐤕𐤕	𐤕𐤓 𐤕𐤔		- Diagram I,4		
11			𐤕𐤓				
12	na	𐤕𐤁	𐤕𐤁		- Diagram I,3		
13			𐤕𐤁				
14	ko	𐤕𐤅 𐤕𐤆	𐤕𐤅		- Diagram I,6		
15	po	𐤕𐤅 𐤕𐤆	𐤕𐤅	𐤕𐤁.		68 𐤕𐤅	32 𐤕𐤅 𐤕𐤆
16	ro	𐤕𐤅 𐤕𐤆 𐤕𐤇	𐤕𐤅 𐤕𐤆	𐤕𐤅.		101 𐤕𐤅	94 𐤕𐤅 𐤕𐤆 𐤕𐤇
17	ts (Carian)		𐤕𐤅				
18	h'e (Carian)		𐤕𐤅				
19	lo	𐤕𐤅 𐤕𐤆	𐤕𐤅		- Diagram I,11		
20	su	𐤕𐤓 𐤕𐤔	𐤕𐤓	𐤕𐤅 Th.	𐤕𐤓 50 𐤕𐤓	𐤕𐤓 25 𐤕𐤓	
21	u	𐤕𐤓 𐤕𐤔 𐤕𐤕 𐤕𐤖	𐤕𐤓	𐤕𐤅 (?) Th.	32 𐤕𐤓 𐤕𐤔	41 𐤕𐤓 𐤕𐤔	
22			𐤕𐤅				
23			𐤕𐤅-3	𐤕𐤅-33	𐤕𐤅-40		

Diagram II. A. = Asine; O. = Orchomenos; Th. = Thebes.

To these are added, according to Schaeffer, *Missions en Chypre*, p. 120, two more signs painted on the bases of jugs, Nos. C. 575 and 583.

The script, however, has been used in this way not only in Cyprus. In order to settle the question of their significance I have tried to make a survey of the hitherto published inscriptions on vases from the Mycenaean period outside Crete. In Crete, of course, there are plenty of them. I am quite aware that the subjoined list is incomplete but I hope that it will lead to a further examination of the Mycenaean vases in the museums, where, no doubt, quite a good deal of material still remains unnoticed.⁹

LIST OF INSCRIBED VASES AND OTHER OBJECTS

- Cyprus* 1—20. Enkomi. Here published, p. 602.
21. Enkomi. Here reproduced, p. 606, No. 11; Markides, *Cyprus Annual Report* 1916, p. 18; *Man*, 1934, 26—27, p. 24 f.; Evans, *Palace of Minos*, IV, p. 759.
- 22—24. Enkomi. Here reproduced, p. 607; *Brit. Mus. Cat. of Vases*, I:2, C. 430, 523, 555.
25. Idalion. Here published, p. 603. No. 21.
- 26—33. Skouriotissa—Katydhata. Here reproduced, p. 606; Markides, *op. cit.*, p. 16 f.
- 34—35. Arpera. Here reproduced, p. 606; Markides, *op. cit.*, p. 17 f.
- 36—37. Maroni. Here reproduced, p. 607; *Brit. Mus. Cat.*, C. 379, 477.
- 38—39. Kourion. Here reproduced, p. 607; *Brit. Mus. Cat.*, C. 391, 501.
- 40—41. Klavdia. Here reproduced, p. 607; *Brit. Mus. Cat.*, C. 412, 514.
42. Hala Sultan Tekké. Here reproduced p. 607; *Brit. Mus. Cat.*, C. 434.
- 43—48. Enkomi. Terracotta balls. Murray-Walters-Smith, *Brit. Mus. Excavations in Cyprus*, p. 27; Evans, *Scripta Minoa*, I, p. 70; Persson, *Some inscribed terracotta balls from Enkomi*, in *Symbolae Philologicae O. A. Danielsson octagenario dicatae*, Uppsala 1932, p. 269 ff.; Evans, *Palace of Minos*, IV, p. 759 ff.¹⁰
49. Hala Sultan Tekké. Terracotta ball. Cf. above.
50. Idalion. Spindle-whorl. Here published, p. 603.
51. Maroni. Gold ring. Evans, *Mycenaean Cyprus*, in *Journ. Anthr. Inst.*, XXX, p. 109; id., *Palace of Minos*, IV, p. 759.
52. ? Cylinder (Cesnola Collection). Ward, *Seal Cylinders of Western Asia*, No. 1164, p. 344 f.
53. Paraskevi. Cylinder. Ward, *op. cit.*, No. 1165, p. 345.
54. Enkomi. Cylinder. *Brit. Mus. Excavations in Cyprus*, Pl. IV, 744.
55. ? Cylinder (Louvre). Dussaud, *Les civilisations préhelléniques*, p. 429, Fig. 320.

56. ? Cylinder (Louvre). Dussaud, *op. cit.*, p. 429, Fig. 319.
57. Idalion. Cylinder. Here published, p. 603.
58. Salamis. Cylinder. Bossert, *Padi*, in *Altorientalische Studien Bruno Meissner gewidmet*, Leipzig 1929, p. 274 ff.
- Syria.*
Ras Shamra. Schaeffer, *Missions en Chypre*, p. 120.
Silver cup. Evans, *Palace of Minos*, IV, p. 783.
- Palestine.*
Tell Abu Hawam. Hamilton, R. W., *Excavations at Tell Abu Hawam in Quarterly of the Department of Antiquities in Palestine*, IV (1935) p. 53.
1 weight (?) of limestone¹¹. *Ib.*, p. 57. (106).
Tell el Hesy. Bliss, F. J., *A mound of many cities*, p. 21—30.
- Egypt.*
Kahun, Gurob. Flinders Petrie, *Illahun, Kahun and Gurob*, Pl. XV.
- Asia Minor.*
Troy. Two Mycenaean potsherds. Schmidt, H., *Trojanische Altertümer* No. 3392, 3486. Other inscriptions, Sayce, *Die Inschriften von Hissarlik* in Schliemann, *Ilios*, p. 766 ff.
Samsoun. Clay ram. Evans, *Palace of Minos*, IV, p. 768.
- The Aegean islands.*
Rhodes. Schaeffer, *Missions en Chypre*, p. 120 f.
Phylakopi. *Excavations at Phylakopi in Melos*, pp. 177, 180.
- The Greek mainland.*
Mycenae. Tsountas-Manatt, *The Mycenaean Age*, p. 268 ff.; Evans, *Scripta Minoa*, I, p. 58. *Annals of the British School at Athens* XXV, p. 20 f.; Evans, *Palace of Minos*, IV, p. 742. Stone pestle. *Πρακτικά*, 1889, p. 19. Stone vessel. Tsountas-Manatt, *op. cit.*, p. 269; Evans, *Scripta Minoa*, I, p. 59.
Tiryns. Sundwall, *Die kretische Linearschrift*, in *Arch. Jahrb.*, XXX (1915), p. 63 f.; Evans, *Palace of Minos*, IV, p. 741 f.
Nauplion (Pronoia). Tsountas-Manatt, *op. cit.*, p. 268; Stais, *Αρχ. Εφ.* 1895, p. 261, Pl. XI, 4—4a.
Asine. Persson, *Schrift und Sprache in Alt-Kreta*, p. 4 ff.; id., *Die spätmykenische Inschrift aus Asine*, in the publication edited by the Swedish Institute at Rome, II, p. 208 ff.; Evans, *Palace of Minos*, IV, p. 755 ff.
Midea. Handle of a stirrup-vase with incised *ka*. Surface find.
Eleusis. Kouroniotis, *Αρχ. Δελφών* 1931—32; *Πρακτικά*, p. 23.; Evans, *Palace of Minos*, IV, p. 744, Suppl. Pl. 69. Mylonas, *Eleusiniaka* in *American Journal of Archaeology*, 1936, p. 427 ff.
Menidi. Tsountas-Manatt, *op. cit.*, p. 268; Evans, *Scripta Minoa*, I, p. 58.
Thebes. Evans, *Palace of Minos*, IV, p. 739 ff.
Orchomenos. Evans, *Scripta Minoa*, I, p. 57; id., *Palace of Minos*, IV, p. 739.
Delphi. Bronze axe. Evans, *Scripta Minoa*, I, p. 58 f.
Tsaritsani. *Πρακτικά*, 1914, p. 163; *Arch. Anzeiger*, 1916, p. 151 f.



Fig. 316, 317. Inscriptions (No. 10) on handles of stirrup-vase, Enkomi, T. 18. Side-chamber, No. 55.

No matter how incomplete this survey of the late Mycenaean inscriptions may be, it shows that inscribed vases existed throughout the region of that culture though they are few in comparison with all vases preserved. It would be incorrect to explain all the inscriptions in the same way. As far as I can see there are four different possibilities to be reckoned with:

1. Potters' marks.
2. Owners' marks.
3. Marks of dedication.
4. References to the contents.

1. *Potters' marks.* It is generally known that in earlier times marks were used to a great extent within the Aegean region both on stones as stone-cutters' marks and on vases. The latter are generally recognized as the potters' marks, especially since they are usually painted or inscribed in the soft clay before baking.¹² As all the Cyprian signs published here for the first time with one exception are incised after baking, this explanation does not seem to hold good here.¹³)

2. The suggestion that *names of the owners* sometimes were inscribed on the vases is

confirmed by the circumstance that this was the case in the Classic period. Sometimes the name is written so that there can be no doubt of the meaning, as is the case with a vase from Cyprus in the Cesnola collection, $\Delta\alpha\iota\alpha\tau\iota\sigma\alpha\sigma\iota\ \dot{\iota}\mu\acute{\iota}$.¹⁴ The handle of a jug with a similar inscription was found at Idalion but by mistake it was omitted in Appendix V in *Swed. Cyp. Exp.*, II. It is represented in Fig. 323 and reads: $ri(?)\ te\ ku\ | \ e\ mi = \text{Παζαζο}(?)\ \dot{\iota}\mu\acute{\iota}$. The inscription is to be read from right to left. The signs are impressed before baking.

3. It is evident that *marks of dedication* occurred also on pottery in the Mycenaean period — I refer to the well known bowl from Asine. But as in respect of the new inscriptions it is mainly a question of finds made in tombs, they must refer to a dedication to the dead. The possibility that friends and relatives may have sent gifts in the inscribed vases must not be overlooked. — I wish to draw attention to the tholos in Dendra where we believed it possible to demonstrate that some objects had been thrown down to the dead in the tomb shaft as a farewell offering.¹⁵ But should there be any question of a dedication to the dead, there is no other possibility to be reckoned with than the name of the recipient in the *dative*, and not that of the donor, and this with regard to the conformity of the inscriptions chiefly in Enkomi Tomb 18, Side-chamber. Under such circumstances the inscriptions with the dedication in the dative are very similar to those mentioned above with their genitive.

4. *Reference to the contents*: This explanation of the signs may possibly be supported by the fact that the same sign, *pa*, is found in the beginning of many inscriptions, as in Enkomi, Skouriotissa-Katydhata, Tell Abu Hawam, Mycenae, and Menidi; this is also the case with *ka* in Enkomi and Midea. The objection may be raised, however, that the inscriptions sometimes are inscribed or painted on the bottom of the vases, which must have been very inconvenient in the case of labelling the vases. Furthermore, many vases are not suitable for the transport or storing of food; though most of the signs are found on stirrup-vases or false-necked jugs, three-handled, and other jugs, they occur also on bowls. The signs on the bottom of the vases or on the handles thus relate, as far as I can see, to names. Sometimes, however, there are also signs on the shoulder of the vases, and they are to be explained otherwise. The figure signs on the stirrup-vase from Orchomenos and on the jug from Skouriotissa-Katydhata No. 2 indicate references to the contents. The inscriptions from Thebes — though of different kinds — yet refer, in my opinion, to the character of the contents. The inscriptions from Enkomi 1913, No. 11, and probably also some of the inscriptions from Tiryns, indicate the way of taxation in pre-monetary days.¹⁶ The circumstance that the same inscription, e. g. Enkomi Nos. 3—7, occurs on vases of very different size shows quite clearly that there cannot be any question of references to the weight or capacity in the short inscriptions on the vases — which otherwise would be analogous to *ta* and *si* instead of *talent* and *shikel*.

These general remarks on the various possibilities of explaining the meaning of the signs on the vases seem to indicate that the signs on the handles and on the bottom refer to the owner, while those on the shoulder should be regarded as references to the contents. We shall now revert to the inscriptions published above in order to investigate if the

conditions of finds allow such an interpretation and if reasonable words for names are to be found.

Inscriptions 1—12. In Enkomi, Tomb 18, Side-Chamber, not less than 14 vases with inscriptions were found. These are distributed over six different combinations of signs, which may, however, possibly be reduced in regard to the system of abbreviating names to the first syllables, common in Cyprus during later periods. We must certainly reckon with several burials. "Scattered fragments of about three dead bodies were found in Side-chamber 1" according to the excavation report.¹⁷ It may be questioned whether they might be associated with the groups of signs mentioned above.

We shall commence with the long inscription on the bottom of the crater, No. 12. Its first sign recurs alone on Nos. 1—2; the two first ones on Nos. 3—7, its first and fourth sign at a certain distance from each other, on Nos. 8—11. It is possible that we here have a reference to the same person, whose name is written with the first syllable in No. 1—2, with the first two in Nos. 3—7, and with the first syllable of the christian name and of the father's name respectively in Nos. 8—11. Possibly the greater part of the name is represented in No. 12. The christian name should thus be derived from the name-stem *bata*, common in Asia Minor, which is met with in names as Βατααζ (Telos); Βατααζ (Pis.); Βατααζ (Phryg.); Βατααζαζ.¹⁸ The syllable *na* could be supplemented Να[αωαζαζ] in accordance with two other Cypriote inscriptions, Ὀυαλιων Νααωαζαζ ἡμῶν on a stele, and Πατααζαζ Νααζαζ[αωαζαζ] πατααζαζ[αζ] on a Cypriote coin.¹⁹ I cannot explain the sign *i* within the base-ring.

Inscriptions 13—14. The conditions are similar with regards to the two remaining inscriptions from the side-chamber of Tomb 18. No. 13 has a *ko* on the bottom as the first sign — the second is uncertain — while No. 14, on a three-handled jar, has the signs *ko ko va*, one on each handle. No. 13 shows the first syllable of the name, while No. 14 displays a more complete form of it, which can be associated with the Anatolian stem *kuka*, from which are derived names like Κοκκαζ (Phryg.); Γωκκαζ (Lyc.); Κοκκαζ (Car.); Κοκκαζαζαζ (Phryg.).²⁰ If we assume in our inscription a Κοκκωαζαζ, the form Κοκκωαζ would be obtained in the Classic period in accordance with the usual phonetic transformation. This form is very similar to the Carian name Κοκκωαζ. — In Enkomi, Tomb 18, Side-chamber containing remains of three corpses, we may thus assume that the names of two of them only are mentioned.

Inscriptions 15—16. These are on two vases from Enkomi, Tomb 3, which contained "at least fifteen persons".²¹ There is thus no objection to the assumption that the vases with the inscriptions belonged to different owners.

Inscriptions 17—18. Enkomi, Tomb 11 has provided us with two inscriptions. The signs *ka to* in No. 17 could be associated with the Anatolian name-stem *kada*, from which are derived names such as Καδααζ (Phryg.); Καδααζαζ and Καδααζ (Lyd.).²² With regard to the script with syllables with two contiguous consonants, it would be possible to associate the two signs with a name like Καδααζαζ. No. 18 has only the sign for *lo*, below which two parallel lines are scratched in a decorative manner along either side of the handle. In this tomb 11 skeletons were found.²³ Here, too, different owners can thus be assumed.



Fig. 318. Inscription (No. 12 a) on bottom of amphora, Enkomi, T. 18. Side-chamber, No. 47.



Fig. 319. Inscription (No. 3 b) on bottom of amphora, Enkomi, T. 18. Side-chamber, No. 6.

Inscriptions 19—21. The vases with these inscriptions are imported to Cyprus, too, and belong to the group which is characterized as "Plain White Wheel-made Ware". The signs in the inscriptions 20—21 (only a drawing of No. 19 has been available to me) have generally different character from those on the Late Mycenaean vases, and they do not offer the same possibilities of identifying them with the Cypro-Classic signs, even if the relationship is evident. One feels inclined to think of a local alphabet, probably of Anatolian origin. If, as I believe, the origin of the vases can be ascertained, it would be possible to determinate the local variety of the script. I shall revert to this question later on.

Inscription 22. The steatite spindle-whorl with inscriptions has direct analogies among those found by Schliemann in Troy²¹). The signs on the whorl from Idalion are, however, much more distinct; there can be no doubt about the phonetic quality of the signs, as all of them are to be found also among the Cypro-Classic syllabic script. The combination of signs *pa ti* is already known; it is found on a seal cylinder from Salamis, in the Cesnola collection; and Bossert has recognized it on a Minoan list of names. He has dealt with it in a special study and argues that it should be an original Philistine name.²² If this is right, *lo*, placed on the other cone of the whorl, must be explained as an abbreviation for another name.



Fig. 320. Inscription (No. 11) on handle of jug, Enkomi, T. 18. Side-chamber, No. 74.

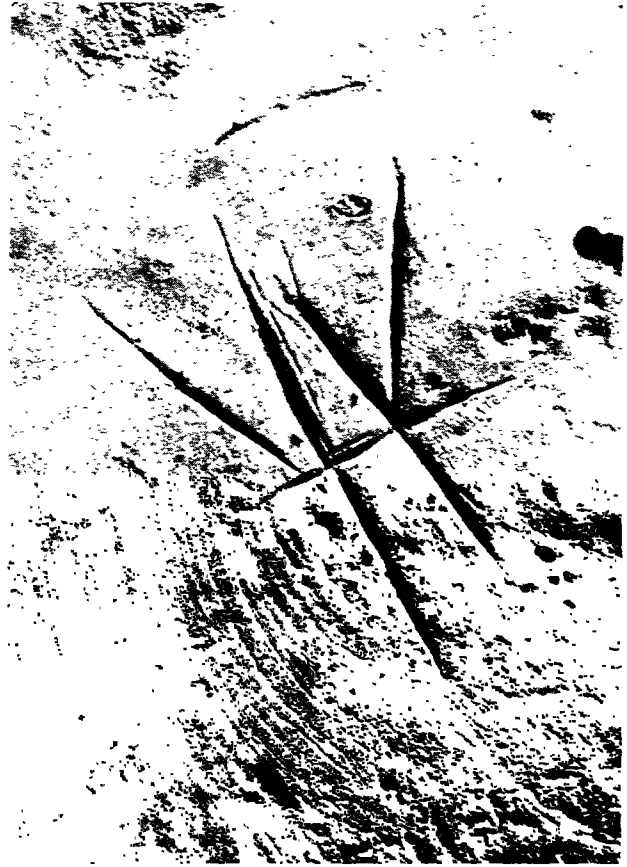

Fig. 321. Inscription (No. 15) on bottom of amphora, Enkomi, T. 3. No. 272.

Inscription 23. The seal cylinder from Idalion is provided with two carefully executed signs, which I read *pa ku*. I associate the man walking to the left, a long nose and hair, well outlined shoulders and a sword or dagger on his belt, with the delineated Cypriote *pa* — a long vertical line with three or two shorter horizontal ones across it. As regards the vertical line split up at the lower end, its analogy is found in the ankh-sign.²⁶ The second sign, which is more conventionalized, shows a double axe with handle right through but without marked edges, as the later Cypriote sign. The striding man indicates the direction in which the inscription is to be read, *pa ku*. Sundwall refers *inter alia* the names Βαζου (Isaur.); Παριδορις (Car.) to a name-stem **paka*, **baka*. In this connexion one is also forced to think of the equivalent of Dionysos, Βάκχος, whose Anatolian origin is certain.²⁷

The inscribed vases from Katydhata, Arpera, and Enkomi, too, published for the first time by Markides, seem to indicate that the signs on the vases bear reference to the owners. As I have had no opportunity to check the originals myself, I shall give up the attempt to interpret them all, but will add a few brief notes on some of them.

It is only from Skouriotissa, Tomb 11, that we have more than one inscription. On the vases from this tomb the name is encountered on the handles as *pa*, on Nos. 1--2; richer as *pa ka* ? on No. 3, which may be compared with the name-stem **paka*, **baka*, mentioned



Fig. 322. Inscription (No. 17) on handle of jar, Enkomi, T. 11, No. 24.



Fig. 323. Inscription (p. 612) on handle from Idalion. The incisions are made in the wet clay, before the baking.

above. The inscription on the shoulder in No. 2 is of a different kind, as the figure-sign 3 to the left indicates, and it should probably be compared with the inscription on the stirrup-vase from Orchomenos and its figure-signs.

Some remarks might be made here on the inscription 11 published by Markides, especially as we have both a photo and a duplicate of it. It was found on a fragment of a pithos belonging to the "Plain White Wheel-made Ware" mentioned above (p. 606). The members of the Swedish expedition, who have worked through the whole material, did not hesitate to determine this ware as imported to Cyprus but they have not been able to ascertain the exact origin of the ware — it is frequently met with in Egypt. The inscription mentioned seems to me to solve this problem. The inscription, which should be read *po pa si ka ro*, can be supplemented in accordance with other Cypriote inscriptions of later date, as follows: $\Pi\sigma[\lambda\acute{\epsilon}\mu\omega\nu] \beta\alpha\tau[\lambda\acute{\epsilon}\delta\epsilon] \text{Καρο}[\nu]$. One may compare the legends on Cypriote coins, as *ta mo ni pa si* = $\Delta\alpha\mu\omega\nu[\lambda\omega] \beta\alpha\tau[\acute{\epsilon}\Phi\sigma]$ and *pa si le vo se ni ko ta mo* || *ni se la mi ni* = $\beta\alpha\tau[\acute{\epsilon}\Phi\sigma] \text{Νι}[\chi\sigma\delta\acute{\alpha}\mu\omega] \Sigma\acute{\epsilon}\lambda\alpha\mu\omega\nu[\omega\nu]$. i. e. Nicodamos, king of Salamis.²⁸ Inscriptions of exactly the same kind as that on the pithos-fragment from Enkomi are previously supposed to have been found on some of the stirrup-vases from Thebes²⁹, and on the inscribed terracotta balls from Enkomi — later on, similar inscriptions occur in Palestine.³⁰ I associate them with the pre-monetary system of taxation.

If this inscription is correctly interpreted it may be assumed that it was written on the vase in Caria and as the ware here concerned is imported to Cyprus it originates most likely from Caria. I have already suggested in the preceding that the script should be regarded as a local alphabet, and this suggestion is confirmed by the fact that the sign on the Skouriotissa vase,

No. 4, which recurs as the first sign on the Arpera pithos, No. 9, is a pure Carian syllabic sign pronounced *ri* in the Classical Carian script.³¹ Cf. also the signs, Nos. 17 and 18, on Diagram II.

The inscriptions on vases in the British Museum, too, if not painted and consequently potters' marks, permit of this interpretation of the signs as referring to the owner. This is clear already from the fact that no tomb has provided us with more than one vase with inscription. In those cases where two signs occur they are easily associated with known Anatolian name-stems and names: *su la*, **zula*, Σουλλας (Isaur., Cil.); *ta ta*, **dada*; Δαδας (Phryg., Cil.); *ka ta*, **kada*, Καδας (Isaur.).

The result of this investigation may seem strange, i. e. that the names met with among the material concerned should be of Anatolian character. But they fit well our assumption that the signs have reference to the owner, and not to the potter. Besides, many vases are purely Mycenaean. No doubt we must reckon with a population in Cyprus originally very closely related to the Anatolian one. This is shown both by the archaeological and the anthropological material.³² This population of Cyprus did not arrive in close touch with the Greeks until the Mycenaean period. Towards the end of this period the island was subjected to such a strong Greek influence that it changed the further cultural development. It is, therefore, not surprising, but quite natural, that the name-stems and single names are the same as in Asia Minor in later periods.

The results at which we have arrived by this investigation of the Mycenaean inscriptions on vases from Cyprus, would thus be that the incised inscriptions on handles and bottoms refer to the name of the owner, probably in the genitive, as indicative for the possession or possibly in the dative as a dedication; furthermore, that inscriptions on the shoulders of the vases, at least in some cases, have a reference to the contents of some kind.

AXEL W. PERSSON.

NOTES

1. Cf. Sundwall, *Zur vorgriechischen Festlandsschrift* in *Klio*, 22 p. 231.
2. Cf. Persson, A. W., *Schrift und Sprache in Alt-Kreta*, p. 7.
3. Cf. Lidell and Scott, *A Greek-English Lexicon*.
4. Cf. Sundwall, *Die einheimischen Namen der Lykier nebst einem Verzeichnisse kleinasiatischer Namenstämme*, *Klio*, Beiheft 11, p. 163.
5. Evans, *Palace of Minos*, IV, p. 758 ff.
6. Markides, M., in *Cyprus, Annual Report of the Curator of Antiquities 1916*, Nicosia 1917, p. 16 ff.
7. The latter is published somewhat differently by Evans, *Palace of Minos*, IV, p. 759 — cf. p. 606.
8. Evans, *Palace of Minos*, IV, p. 759 speaks, incorrectly, of "a limestone fragment . . . with graffito characters" while Myres, whose announcement in *Man* 1934, 26, p. 24 he quotes, mentions the fragment of a large clay store-jar. The copy made by Evans from a photo does not seem to be of the same value as Markides' copy from the original, together with the photo, published by Myres (Fig. 1) and his statement that Evans "with the aid of a strong lens" was able to discover a sign on the copy. Neither of them seems to have known that Markides had published the inscription.
9. Inscriptions on other objects than vases have been included in the list in order to show better the spread of the script. If nothing else is stated the inscription is applied on a vase. — During the American excavations at Kurion in Cyprus,

- conducted by Mr. B. H. Hill, some inscriptions were recently found similar to those here published. Mr. J. I. Daniel, who has kindly placed at my disposal the photos of the same will soon publish them in *American Journal of Archaeology*, and the reader is, therefore, referred to his publication.
10. In spite of Evans' objection, *op. cit.*, p. 760, footnote 2, the suggestion that these terracotta balls are weights, as I have supposed, is confirmed by the weighing of them which, at my request, was made by Mr. Forsdyke
 11. Incised letter or mark on the edge.
The weight of the disc is not given but there can be no doubt that we have one of the usual weights in the shape of a flat disc. Cf. Evans, *Minoan Weights and Mediums of Currency from Crete, Mycenae and Cyprus*, in *Corolla Numismatica. in honour of Barclay V. Head*, p. 343. The sign indicates to which of the current systems of weights it belongs. It is $\tau\acute{\iota}\text{-}\tau\acute{\iota}\text{-}\tau\acute{\iota}$ or $\tau\acute{\iota}\text{-}\gamma\acute{\iota}\text{-}\tau\acute{\iota}$, the so-called Phoenician shekel. We have thus a complete parallel to the occurrence of the sign *ta*, abbreviation of $\tau\acute{\alpha}\text{-}\lambda\acute{\alpha}\text{-}\tau\acute{\alpha}$ on the copper talents from Ajia Triada, one of which is reproduced by Evans in *Corolla Numismatica*, p. 357. Fig. 12; also in *Palace of Minos*, IV, p. 652; an explanation which I have given already in *Schrift und Sprache in Alt-Kreta*, p. 20.
 12. Cf. e. g. Edgar, *The pottery marks*, and Evans, *Significance of the Pottery marks in Excavations at Phylakopi in Melos*, p. 177. Similar signs though not very common are found practically all over the mainland in E. H.- and M. H.-layers.
 13. As to painted signs, potters' marks, from the Mycenaean time, cf. Schaeffer, *Missions en Chypre, 1932—1935*, p. 119 ff. In Phylakopi, too, some inscribed signs were found. Edgar says, *op. cit.*, p. 177: "The scratched signs . . . are as a rule later than the impressed marks" and that they "were more probably added by the owner after the vase had come into his possession".
 14. Collitz-Bechtel, *Sammlung der griechischen Dialektschriften*, I, p. 26, No. 58.
 15. Persson, *The royal Tombs at Dendra near Midea*, Lund 1931, p. 70.
 16. Persson, *Some inscribed terracotta balls from Enkomi*, p. 272 f.
 17. *Swed. Cyp. Exp.*, I, p. 550.
 18. Cf. Sundwall, *Die einheimischen Namen der Lykier*, p. 60.
 19. Cf. Collitz-Bechtel, *Sammlung der griechischen Dialektschriften*, I, p. 17, No. 21 and p. 66, No. 194.
 20. Cf. Sundwall, *op. cit.* p. 120.
 21. *Swed. Cyp. Exp.*, I, p. 477.
 22. Cf. Sundwall, *op. cit.*, p. 92 f.
 23. *Swed. Cyp. Exp.*, I, p. 514.
 24. Cf. Schliemann, *Ilios*, Tafeln, and p. 766 ff. Anhang III; Sayce, *Die Inschriften von Hissarlik*; H. Schmidt, *Trojanische Altertümer*, Nos. 5209—5224.
 25. Bossert, H., *Padu*, in *Altorientalische Studien Bruno Meissner gewidmet*, Leipzig 1929, p. 274 ff.
 26. Cf. Evans, *Palace of Minos*, IV, Fig. 666., Type B 24 and A 36.
 27. Cf. Wilamowitz-Moellendorf, *Glaube der Hellenen*, II, p. 61.
 28. Cf. Collitz-Bechtel, *op. cit.*, p. 51, No. 151 and p. 59, No. 176.
 29. Cf. Persson, *Schrift und Sprache in Alt-Kreta*, p. 28 f; id., *Die spätmykenische Inschrift aus Asine*, p. 214.
 30. Cf. Persson, *Some inscribed terracotta balls from Enkomi*, p. 273.
 31. Cf. Bork, F., *Die Schrift der Karer*, in *Archiv für Schreib- und Buchwesen*, IV, p. 21, No. 34.
 32. Gjerstad, *Studies on prehistoric Cyprus*, p. 293 ff; Fürst, C. M., *Zur Kenntnis der Anthropologie der prähistor. Bevölkerung der Insel Cypern*, Lund 1933.

A P P E N D I X I I

Die Legende der Münze Vouni No. 292 u) 11 bietet Schwierigkeiten. Zwar die vier Buchstaben rechts vom Kopfe des kämpfenden Herakles sind klar: sie lauten לִמְלֶךְ (LMLK). Nach Analogie anderer cyprischen Münzen würde man sie gern zu dem Namen eines Königs, z. B. מֶלֶכִּיָּאֶתוֹן, Melekiathon (cf. Hill, *Cat. Gr. coins of Cyprus*, S. XXXV) erweitern. Aber es folgt eben kein ך, und dass eine punische Inschrift die kürzere Form מֶלֶכִּיָּאֶתוֹן bietet (Lidzbarski, *Handbuch der nordsemitischen Epigraphik*, S. 311), darf man hier nicht heranziehn. Es ist übrigens ebenso möglich, dass diese vier Buchstaben ein Wort für sich bilden. Links von dem Kopfe werden die Buchstaben undeutlich, wahrscheinlich infolge einer Überprägung. Wenn das erste Zeichen links ein Buchstabe ist und nicht etwa zum Bilde gehört, wird man in ihm am liebsten ein ך sehn, das auf Reisner's Ostraka (*Harvard Excavations at Samaria*, 1924, I S. 243) diese Form hat; doch wäre auch ein ם möglich. Dann folgt ziemlich sicher ein ן; aber die folgenden beiden Buchstaben sind ganz unsicher, und bei dem ך am linken Rande schwankt man, ob er noch zu den vorhergehenden Buchstaben zu ziehn ist oder mit ihm ein neues (überprägtes) Wort beginnt, zu dem dann auch das einem ך gleichenden Zeichen unter der Keule gehören könnte. Immerhin wäre die Lesung מֶלֶכִּיָּאֶתוֹן ךׁ nicht ausgeschlossen. (Pl. XCVII, 5).

Die Münze Vouni No. 292 u) 12 kann nach ihren Bildern (kämpfender Herakles und Athene Promachos) nur unter den Königen Melekiathon oder Demonikos von Kition (Hill, *op. cit.*, S. XXXV—XXXVII) geprägt sein. Da die ersten vier Buchstaben der Legende leicht als לִמְלֶךְ (לִמְלֶךְ, LMLK) zu lesen sind, erwartet man im folgenden die Zeichen מֶדֶן (מֶדֶן, ITN). Allein diese stehen in keinem Falle da: es kommt also nur der König Demonikos in Frage und das לִמְלֶךְ ist nicht Anfang des Namens, sondern Titel: „des Königs“ (cf. Hills Liste S. 111/2). Die folgenden 2 oder 3 Zeichen können dann aber nicht den ganzen Namen wiedergeben, sondern sie sind eine Abkürzung, wie solche vielfach auf cyprischen Inschriften vorkommen. Andere Abkürzungen, z. B. כֶּךְ für כְּעֶלְמֶךְ (Hill, *op. cit.*, S. XXXI) lehren, dass man in solchen Fällen gern den ersten und letzten Buchstaben des Namens zusammenstellte, und so kann man auch auf unserer Münze die

Buchstaben Δ (τ , D) und \aleph (τ , K) erkennen, also D(emoni) K. Es ist zweifelhaft, ob der durchbrochene Strich, der noch hinter dem τ folgt, den Rest eines Buchstabens darstellt oder nicht. Ist dies der Fall, so hindert nichts, darin den unteren Schaft einer τ (τ , V), das heisst die semitische Wiedergabe der griechischen Genitivendung ω zu sehen; vergl. Babelons Lesung $\tau\tau\tau\tau\tau\tau\tau\tau\tau$ bei Hill, *op. cit.*, S. XXXIX. Die Legende wäre also $\tau\tau\tau\tau\tau\tau\tau\tau\tau$ oder evtl. $\tau\tau$ zu lesen (LMLK DKV oder DK) und entspräche einem griechischen $\xi\alpha\pi\iota\lambda\acute{\epsilon}\omega\varsigma\ \Delta\gamma\mu\omicron\nu\acute{\iota}\kappa\omicron\upsilon$. (Pl. XCVII, 6).

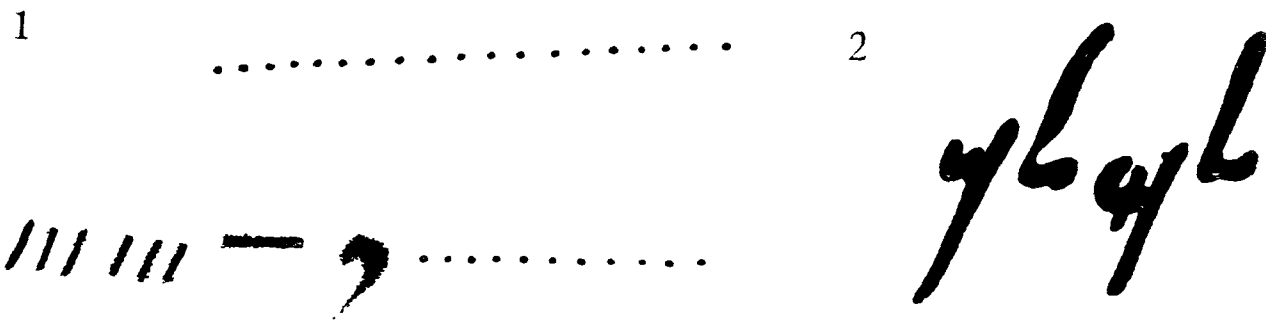

Fig. 324. Phoenician inscriptions, Vouni, T. 4, No. 3 (1); Vouni T. 15, No. 2 (2).

Die Aufschrift auf dem Krüge Vouni, T. 4, No. 3 ist in der oberen Zeile sehr verblichen, doch meint man nach den Spuren sagen zu können, dass es phönizische Buchstaben sind. Die zweite Reihe bringt Zahlen, von links gelesen $3+3+10+20$. Über die Form der Ziffer 20 vergl. Lidzbarski, *op. cit.*, S. 200. Man fühlt sich versucht, auch die vorhergehenden Zeichen als Ziffern zu deuten — etwa $100+1,000?$ — aber sie sind zu sehr verwischt. Ebenso ist die Frage nicht zu beantworten, worauf sich diese Zahlen beziehen, aber die Vermutung, dass es sich um ein Mass handelt, liegt nahe. (Fig. 324, 1).

Die Krugaufschrift Vouni, T. 15, No. 2 lautet deutlich $\tau\tau\tau$ (LMLK), „dem Könige gehörig“. Gleichlautende Stempel auf jüdischen Amphoren werden von Watzinger (*Denkmäler Palästinas*, I, S. 116, wo auch zwei Abbildungen) besprochen. (Fig. 324, 2).

WILH. RIEDEL.

A P P E N D I X I I I

GREEK INSCRIPTIONS

VOUNI

1. *Vouni*, No. 453.

Find place: The palace. Room 13, Layer 5. *Material and size:* White Grounded terracotta lekythos. Height 29. 2. (Pl. LXXXVI, 1—2).

Α Λ Κ · · Α Χ Ο , Ἀλκ[ιμ]αχ[ο]ς[ε].

A *καλός*-inscription painted in front of the face of a female figure. For Ἀλκίμαχος, see Klein, W., *Die griechischen Vasen mit Lieblingsinschriften*, Leipzig 1898, pp. 165 f.

MERSINAKI

2. *Mersinaki*, No. 740.

Find place: Temple-site at Mersinaki. *Material and size:* White marble plaque. Height 32.0. Width 22.7. Thickness 5.3. (Pl. CXLVIII, 11).



 Ἀρσινόης
 [Φ]ιλαδέλφου

Since Arsinoe was married to Ptolemy, most likely in 276, and died in 270, the inscription must be dated to this epoch; it can in no case be older.

There has been a great deal of discussion about the meaning of this inscription, which, on other occasions have been found in some ten copies in various parts of the Greek world, in most instances in Cyprus: according to Perdrizet (*Bull. Corr. Hell.*, XX, p. 358) and Dittenberger (*Or. Gr. Inscr.*, I, 34) one from Lesbos, two from Amorgos, one from Thera, one from Paros, and five from Cyprus (amongst them three from Amathus, one from Ialoussa in the Carpass and one from Larnaca). Perdrizet (*op. cit.*) is of the opinion that all these inscriptions do not refer to gifts by Arsinoe but to votive offerings, dedicated to Arsinoe in the shape of a goddess: "Tous ces ex-votos seraient bien in-

dignes d'une souveraine dont la richesse était immense, et dont la munificence est connue." Dittenberger (*op. cit.*) is among those who argue that Arsinoë herself is the donor "...statuimus per unam eandemque occasionem reginam ad omnia Graecorum qui in Lagidarum fide essent delubra eiusdem generis dona misisse, quorum tenuitas nescio an eandem modestiae affectationem habuerit quae in titulo observatur. Atque omnium quidem maxime probabile existimo, ipsas nuptias Ptolemaei et Arsinoës his muneribus offerendis ansam praebuisse."

3. *Mersinaki*, No. 750.

Find place: Temple-site at Mersinaki. *Material and size*: Block of sandy limestone. Height 19.2. Length 51.0. Width 34.0. (Pl. CXLVIII, 10).

ΝΙΚΑΝΔΡΟΣ ΑΥ Νίκανδρος ἀν[έθυκεν]

4. *Mersinaki*, No. 839.

Find place: Temple-site at Mersinaki. *Material and size*: Base for a statue of hard, white limestone. Height 7.1. Width 11.4. Length 17.3. (Pl. CXLVIII, 7).

ΠΕΝΙΞΚΟΣ ΙΙΙ ΕΙ
 ΤΟΥ ΥΙΟΥ ΟΝΑ ΑΠΟ ΜΜ^ς
 ΝΙΛΥΚΙΩΝ ΕΥΧΗΝ [Παρ]μενίσκος ὕπερ
 τοῦ υἱοῦ Ὀνά Ἀπόλλω-
 νι Λυκίῳ ἐθήλη.

[Παρμενίσκος] Some indistinct traces of the first letter remain which can be explained as Π.

[Ὀνά] The abbreviated name Ὀνάς is very rare. Evidently the original name is abbreviated twice so that it has possibly developed from Ὀνασαγόρας via Ὀνασᾶς to Ὀνάς. Cf. Σεραπόδιωρος : Σεραπᾶς : Σεραᾶς. (Cf. App. IV, No. 9, p. 637).

5. *Mersinaki*, No. 1037.

Find place: Temple-site at Mersinaki. *Material and size*: Hard, grey limestone. Inscribed face 6.6 · 12.2.

ΗΡΟΣ

6. *Mersinaki*, No. 1080.

Find place: Temple-site at Mersinaki. *Material and size*: Plaque of white marble. Height 15.0. Width 12.0. Thickness 6.7. (Pl. CXLVIII, 9).

The style of the characters is rather clumsy. An incised line is still visible above the first line. Not only Ω but Σ, too, in the first line occupy half the height of the line.

<p> Α Σ Ι Λ Ε Ω Ζ Η Τ Ο Λ Ε Μ Α Ι Ο Υ Θ Ε Ο Υ Ε Π Ι Φ Α Ν Ο Υ Σ </p>	<p> [B]ατολιζωζ Ητολεμαί- ος θεος επι- φανος. </p>
---	---

The inscription must thus be dated to the epoch 203—180 B. C.

7. *Mersinaki*, No. 1089.

Find place: Temple-site at Mersinaki. *Material and size:* Block of hard, grey limestone. Height 19.5. Width 13.2. Thickness 15.4.

ΑΘΗΝΑ

SOLI. TEMPLES AT CHOLADES

8. *Soli*, No. 322.

Find place: Central cella of Temple of Serapis. *Material and size:* Marble tablet of which two fragments remain, a larger one about 20.0 × 34.0 cm.; and a smaller one triangular in shape, 12.0 × 13.0 cm. As to the size of the whole, original tablet, see below.

The characters, always provided with “*Zierhäkchen*”, are very regular in shape. The lines are marked by incised grooves, still visible. The distances between them are 4.1 cm. The height of the letters is 4.0 cm., with the exception of O, E, and C which are 3.5 cm. The whole of the last line is only 3.5 cm. The width of the letters, too, is very regular. A, Λ, and E are 2.0 cm.; each part of the bent cross-line in A is 1.0 cm. as is also the cross-line in E; the width of M is no less than 4.0 cm., and is shaped like a double Λ; H is 1.5 cm. and O 2.5 cm. wide. The distance between letters with vertical lines is regularly 1.0 cm.; between others, it varies according to their shape. — On the minor fragment is a vertical line indicating the end of the script. The line is, however, intersected by the third line of letters; the line runs straight through O. Above O, in the head-line, there is a dot apparently indicating the middle of the line. The words are separated by dots at the half of the height of the letters (cf. No. 12, p. 626).

Judging by the fracture of the small fragment, ων seems to constitute the end of the second line of the large fragment.

The completion of this inscription presents certain difficulties. ερηγς in the second line can thus be either the end of a word or two words (ὕπερ ερηγς. or something similar). It seems also impossible to ascertain which of the words are names.

The fragments have the following appearance

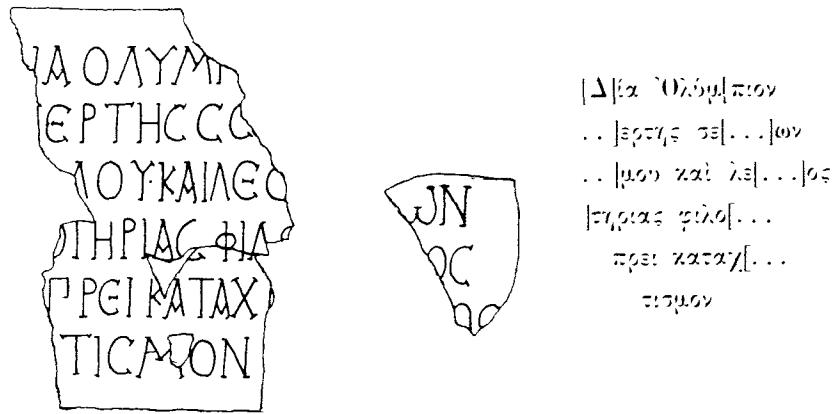

Δία Ὀλύμπιον] This head-line indicates that the marble slab belonged to a base of a statue of Zeus. The circumstance that the slab was found in the cella of Temple E confirms the suggestion, proposed by Westholm, *op. cit.*, p. 152, that the temple must be identical with the one mentioned in the *Acta Aux.* as templum Iovis Dei.

τηρίας] If we complete this as σωτηρίας we can compare the inscription with *Or. Gr. Inscr.*, 2.706: Εἴσιδε Φαρία Εἴσιον τῆν ἐν Μενούθῃ ὑπὲρ σωτηρίας τοῦ κυρίου ἡμῶν Ἀυτοκράτορος Ἀντωνείνου.

τισμόν] The plain portions of the marble slab before τ and after ν are so large that there can be no doubt that we have here all the letters of the last line placed on about the middle of the line for reasons of symmetry. In view of the slab originally being of a rather modest size on account of its function, one may perhaps be justified in assuming that χ and τισμόν constitute the beginning and the end of the same word, presumably χρισματισμόν. If this is correct, one may draw the conclusion that the whole tablet originally measured about 34 × 60 cm.

The meaning of χρισματισμόν cannot be ascertained because of the fragmentary state of preservation of the inscription. The usual translation of the word in *koine* is "report", "document". One can also determine the meaning as "divine response", which is the only one occurring in the New Testament (Rom. 11, 4) and which also is found in LXX and Patres. If we are justified in translating χρισματισμόν in this way, we are thus confronted with a phrase of the same character as πρόσταγμα Σαράπιος (cf. below Nos. 10—11, p. 625) and analogous with κατὰ μαντεῖαν, which is often found on inscriptions, e. g., *Or. Gr. Inscr.*, I, 319, 10. Cf. also Larfeld, *Handbuch d. griech. Epigr.*, I, p. 555; II, p. 860.

9. *Soli*, No. 323.

Find place: Central cella of Temple E. *Material and size:* Two triangular fragments of a marble slab, the straight sides being 14 × 23 cm. and 11 × 19 cm. resp. The large fragment comes from the upper left hand part, containing the beginning of the text. The small fragment belongs to the right side with parts of three lines.

The letters are carefully formed, all being 3.5 cm. high. They are placed between incised lines. The letters are provided with "Zierhäkchen". In Λ the *hastae* are bent and the right *hasta* prolonged; the cross-line is angular.

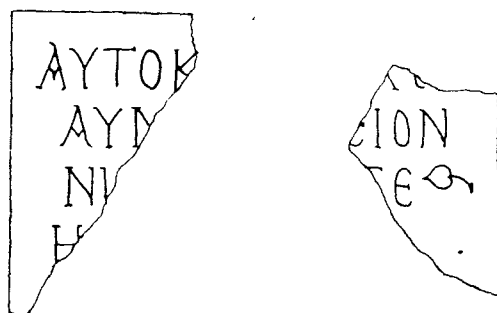

10. *Soli*, No. 409.

Find place: Re-used as a building-stone in the wall of Temple F. *Material and size:* A thick, white marble slab 11.5 × 15.0 × 42.0 cm. The short sides are well cut and flat. The long sides are rough or slightly flattened. (Pl. CLXXIV, 1).
Even and carefully cut characters.



Μοσχίων Κριτοδί-
[μ]ου Ῥόδιος Πριάπου
[ε]ρὸν ἰδρύσατο Σαρά-
πιος πρόσταγμα.

(Cf. Westholm, A., *The Temples of Soli*, p. 151.)

Σαράπιος πρόσταγμα] The usual form is κατὰ πρόσταγμα πινος. In connexion with an example parallel to ours, on an Athenian inscription (*I. G. Ed. Min.*, II, 4734), Nachmansson points out in *Athen. Mitt.*, 33 (1908) p. 209, that the omission of the preposition must "als etwas überaus seltenes betrachtet werden. Nur eine sichere Parallele vermag ich zu geben: ποσίταγμα auf dem Weihgeschenk aus Chalke (etwa II. Jh. vor Chr.) *I. G.*, XII: 1, 957." Our inscription seems thus to be the third known example. — As to the phrase, cf. also Dittenberger, *Syll*³, 1129, 1138, and the note to 1153.

11. *Soli*, No. 428.

Find place: Outside the cella of Temple B. *Material and size:* Base of white marble for two statuettes. Length 41.0. Width 22.4. Thickness 9.0. (Pl. CLXXIII, 15).
Comparatively uniform in style. As to the letters the following characters are noted: Π and italic Ω , both hanging on the line, which may date the inscription to the Roman period; furthermore the type of N.

Σ Α Ρ Α Τ Ξ Ι Ο Ν Α Σ Ι Σ Υ Π Ε Ρ Τ Ο Ν Τ Α Ι Δ Ι Ω Ν Ι Σ Ο Κ Ρ Α Τ Ο Υ Σ
Ε Ρ Ι Ψ Ν Ο Σ Κ Α Τ Α Τ Ρ Ο Σ Τ Δ Γ Ι Α

Σαράπει: Ὀνασις ὑπὲρ τῶν παιδίων Ἰσοκράτους
[καί] Ἑρμῶνος κατὰ πρόσταγμα.

κατὰ πρόσταγμα] Cf. above No. 10, p. 624.

12. *Soli*, No. 465.

Find place: In front of the cella of Temple B. *Material and size:* Marble slab. Length 43.5. Width 18.1. Thickness 3.2. (Pl. CLXXIII, 16).

Even and careful style. Several characters provided with "Zierhäkchen". The division of the words is indicated by dots half way up the line. Larfeld (*Handbuch d. griech. Epigr.*, I, p. 431) points out that similar dots occur very often in the Roman inscriptions of the Empire period. On the other hand, one must remember that already in the Cypriote syllabic script the single dot (*divisor*) was very common for separating the words.

ΑΦΡΟΔΕΙΤΗ·ΟΡΕΙΑ
ΕΠΗΚΩ·ΤΟΝΥΠΝΟΝ
ΤΙΤΟΣ·ΦΛΑΟΥΙΟΣ·
ΖΗΝΩΝ·ΕΥΣΑΜΕΝΟΣ·

Ἀφροδείτη Ὀρεία
ἐπηκόω τὸν ὕπνον
Τίτος Φλάουιος
Ζήνων εὐσάμενος.

Already the Roman name Titus Flavius and the omission of *iota subscriptum* (cf. Bondeson, *De sonis et formis tit. Miles.*, Lund 1936, pp. 54 ff.) show that the inscription must be referred to the Empire period. The shape of the characters, too, especially the independent cross-line in H (first line) indicates the same.

[Ἀφροδείτη Ὀρεία] As to the name Ὀρεία, cf. Westholm's statement about this inscription in *The Temples of Soli*, p. 149: "This is the first time we meet with this name, though Cybele is often identified with Aphrodite." Cf. p. 544, and *I. G. Ed. Min.*, II, 4714, Μητροῦ θεῶν εὐαντή(τω) ἱατρούνη Ἀφροδείτη and Gruppe, in Müller's *Handbuch*, V: 2, 2, pp. 1529 ff.

[ἐπηκόω] This adjective must not be regarded as an epithet in the ordinary sense, an explanation which might be conveyed by the note to *I. G. Ed. Min.*, II, 4742. It might be ascribed to any god even if he is not mentioned by name, as, e. g., in a votive inscription sacred to θεοῖς ἐπηκόοις. Cf. Drexler in *Neue Jahrb. f. Philol. u. Paed.*, 145 (1892) pp. 362 ff.

[τὸν ὕπνον] I am not certain how this object should be interpreted.

Grammatically it ought to be referred to εὐσάμενος, and the whole phrase should in

this case be translated "having asked for sleep". *Ἐύχομαι* occurs, though rarely, with an accusative object. Cf. Xenophon, *Mem.* III, 14, 3 *τοῖς θεοῖς εὐχόμεναι πολιορκασίαν*.

But this explanation does not tally with the usual formula in such inscriptions. The following examples can be mentioned as typical: *I. G. Ed. Min.*, II, 4634 *Ἐύφροσύνη Ἀφροδίτῃ εὐχόμενη ἀνέθηκεν*. 4372 *ὅπερ τῆς γυναικὸς εὐχόμενος Πραξίας Ἀσκληπιῶ*. 4531 *Ἐπιεία καὶ Τελεσφόρῳ Ἀριστείδῃ εὐχόμενος*. The two latter examples show that the predicate can be omitted. In this formula, which is very common, the word *εὐχόμενος* should thus be translated as "having promised" or "under a vow".

Under such conditions *τὸν ὕπνον* should apparently necessarily be regarded as the objective to the omitted *ἀνέθηκεν* as it can evidently not be referred to *ἐπιγνώφ*. Consequently, we have thus to write *τὸν Ὑπνον*. In other words, we ought to interpret the inscription in such a way that Titus Flavius Zeno dedicates a statue of Hypnos to Aphrodite.

The practice of dedicating a statue or a picture of somebody else than the god himself is nothing unusual. As a rule, the picture of a relative seems to have been selected, e. g., *I. G. Ed. Min.*, II, 4857 *Ἀρίστον καὶ Ἀσκληπιάδῃ καὶ Τιμαρχῷ οἱ Τιμαρχῶ τῆν ἑαυτῶν μητέρα Φιλίππῶν Τιμοθέῳ τῷ θεῷ*. But sometimes a god is chosen, who in some respect or other is related to that god to whom the picture is sacred. *I. G. Ed. Min.*, II, 4778 *Δήμητρι Νιόβῃ καὶ Κόρῃ τῆν Κορροσφόρον Εἰσιδοτος ἀνέθηκεν κατ' ὄνειρον*. Cf. *Δελτ.* XII (1929) pp. 76 f.

The personification of Hypnos is comparatively late. There is no pronounced mythology concerning him. But it is significant that Nonnos, the only one who has more in detail dealt with the personified Hypnos, mentions him as *Παφίης θαλάσσιπλόος* (*Dion.* 48, 752), *πομπὸς Ἐρώτων* (*ib.* 16, 283).

But even if Aphrodite in this case is identified with Cybele there is nothing surprising in a statue of Hypnos being sacred to her, as she sometimes appears as the deity of medicine, as in the cited inscription, *I. G. Ed. Min.*, II, 4714. *Μητροῖ θεῶν εὐαντί(τῶ) ιατρῆνῃ Ἀφροδίτῃ* (Cf. *RE.*, article *Kybele*, sp. 2254 f.). The rôle of sleep in the activity of the deities of medicine is clearly shown by a comparison with, e. g., Asclepius, and his activity in Epidaure. One inscription shows that Hypnos also as a *deity* was closely related to Asclepius and other similar deities, *I. G. Ed. Min.*, II, 4467 (dated to "fin. s. I a.") *Ἀσκληπιῶ καὶ Ἐπιείῃ καὶ τῷ Ὑπνῷ θεωρικῶς Συνδρόμῳ Στεφριεῶς χαριστήριον*.

As far as I can see, there is thus nothing to prevent us to interpret our inscription as a parallel to the inscription cited above, *I. G. Ed. Min.*, II, 4778, according to which a picture of *ἡ Κορροσφόρος* is sacred to Demeter and Kore.

13. *Soli*, No. 493.

Find place: Temple of Aphrodite, in front of the cella. *Material and size*: Slab of blueish marble. Only fragments are preserved, some of which could be put together. It is, however, impossible to effect a complete reconstruction of the original slab. As regards some of the minor fragments, it is also impossible to determine to what part of the tablet

they should be attributed. The remaining parts, which cannot be fitted together into one unit, are thirteen in number, the largest being rectangular in shape and measuring 10.3×17.5 cm.

The characters are fairly regular. Α, Λ, and Δ are worthy of notice as the right *hastae* are prolonged. The italic Μ should also be noticed, since the circumstance that ϕ differs in shape in line 2 (where all the letters seem to be more crowded together than in the other lines) from that in line 3 from below: in the former case, ϕ; in the latter, ϕ. The incised lines, indicating the rows of letters are still visible, the distance between them being 15—17 mm. and entirely occupied by the letters. On either side of the slab, the edges were marked by vertical incised lines, on the left side 17—20 mm. from the first letters of the lines, whereas, on the right side, the rows do not terminate at the same distance from the line. One line of letters reaches the incised line in question. The original distance between the incised lines along the edges was about 38.5 cm. The number of lines is, however, impossible to ascertain.

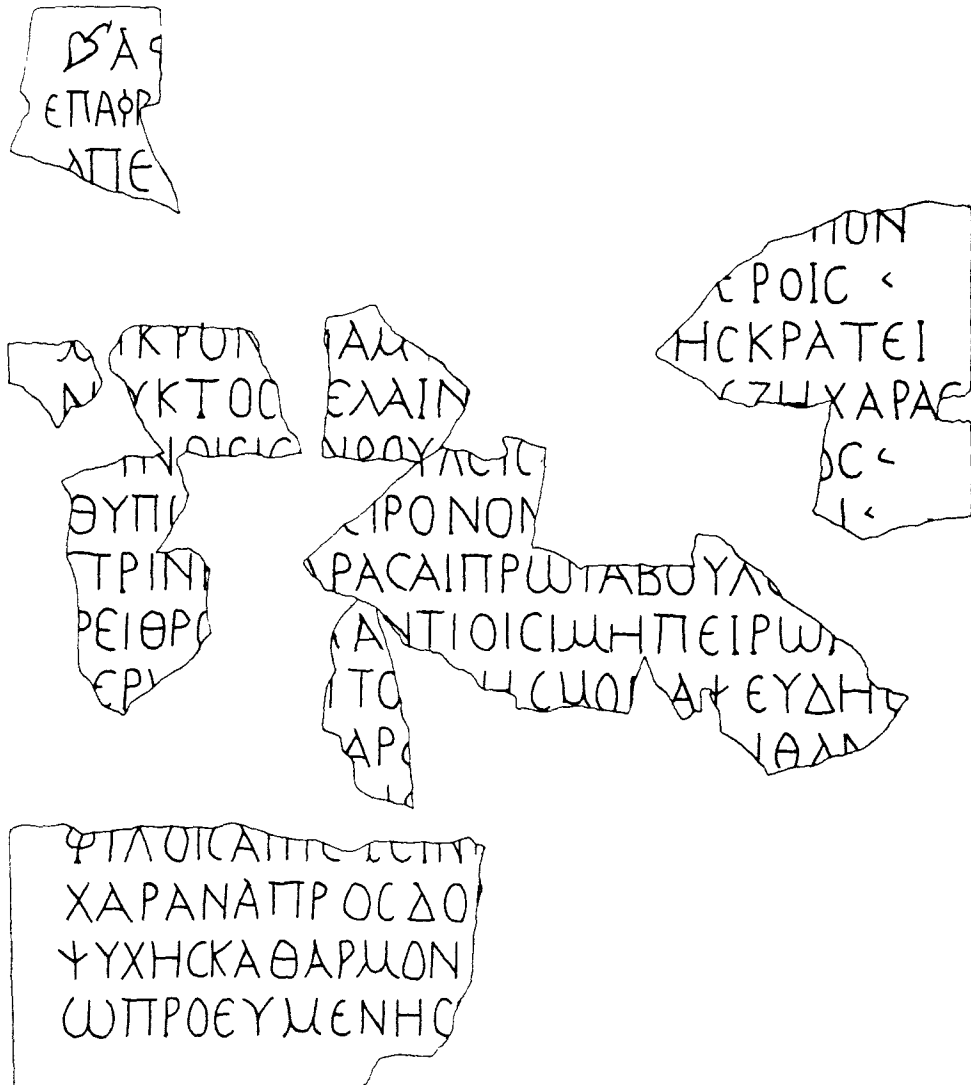

Apart from these larger pieces, the following seven fragments are preserved which cannot be referred to any certain place within the inscription. The largest of them contains the end of three lines.



Ἀφ[ροδίτη
ἐπαφρο[ροδίτ
απε[

.....]πον
.....]εροις <
μικρόν . . . αμ[]γες κραται
νοκτὸς [μ]ελαίν[γες]υζή χαρας
..... ν... .. νβουλαεις[]ος <
θυπ..... ιρονον[
πρὶν ἤ... ρασαι πρώτα βουλ[
ρεϊθρο[ις . .]αντίοισι μὴ πειρωμ[
ερ..... τὸ[ν γρ]ησμὸν ἀψευδῆς[
]αρ[]θαν[

φίλοις ἀπιστεῖν[
χάραν ἀπροσδό[κητον
ψυχῆς καθαρμόν[
ω προσημενῆς[

Evidently we are confronted with a hymn to Aphrodite in iambic senar. Unfortunately the poor state of preservation of the inscription prevents us from interpreting the entire sentence, especially as no other hymn of a similar character to Aphrodite, seems to be known. But some detached phrases permit us to recognize the general sentiment and spirit which pervade the poem. The conception of Aphrodite no doubt belongs to the syncretic period. The phrase about *ψυχῆς καθαρμόν* must thus be referred to this period. The relation of Aphrodite to *νοκτὸς μελαίνης* (if, as is likely, these words re-

fer to Aphrodite) is, however, very old. Already Astarte appears as a moon-goddess Aphrodite has the same character though not so pronounced: she has the epithets $\nu\alpha\lambda\tau\epsilon\sigma\sigma\upsilon$ (*Orph. h.* 55,3), $\sigma\kappa\sigma\tau\iota\gamma\alpha$, etc.

$\theta\upsilon\pi$. . .] As no word beginning with $\theta\upsilon\pi$ occurs in dictionaries, and it is possible to add only a narrow letter before, it seems likely that we have to read $\theta\upsilon$ as a word or part of the same.

$\chi\epsilon\tau\iota\sigma\mu\acute{o}\nu$] When an oracle is mentioned in this inscription it should be remembered that the only known Aphrodite oracle was at Paphos, in Cyprus (Cf. Bouché-Leclercq, *Hist. de la divination dans l'ant.*, II, pp. 391 ff.).

$\pi\rho\sigma\epsilon\upsilon\mu\epsilon\nu\gamma\acute{\iota}\varsigma$] This word seems to be $\tilde{\alpha}\pi\alpha\tilde{\iota}\lambda\epsilon\gamma$, and constructed analogously to $\pi\rho\acute{o}\lambda\alpha\lambda\upsilon\varsigma$ "exceedingly bad", $\pi\rho\acute{o}\beta\alpha\theta\upsilon\varsigma$ "very deep", etc. in which the $\pi\rho\sigma$ - adds stress to the simple adjective.

14. *Soli*, No. 512.

Find place: Amongst the stones fallen from the walls of the cella of Temple B. *Material and size:* Square plaque of grey, hard limestone. Length 30.0. Width 28.0. (Pl. CLXXIV, 2).

The characters are partly worn away, which makes reading difficult. Over the original inscription are two incised, concentric circles showing the slab to have been used over again subsequently. *I. G. Ed. Min.*, II, 5190 shows a similar double circle, the stone is there explained as "fragmentum epistylia(?)".

Ρ°Δ|ΟΥΚΡΙΤ°ΔΑΜ°
ΣΦΩΓΓ°ΝΕΩΝΑ
ΔΡΑΚΩΝΔΕΧΩΡΟΝ

Ῥοδίου Κριτοδαμοῦ
στῶν γονέων α[
Δράκων δὲ γῶρον

Evidently this is a "*Weihinschrift*" according to which a building (?) or an altar (?) with site is dedicated by the children in honour of the parents.

Ῥοδίου Κριτοδαμοῦ] This should be compared with the name mentioned on the inscription, No. 10, where the name $\text{Μοσχίων Κριτοδάμου Ῥόδιος}$ occurs. It may be difficult to ascertain whether in this latter inscription we meet with a son of Moschion of the former one. Note also the change of the vowel $-\delta\alpha\mu\omicron\varsigma$; $-\delta\gamma\mu\omicron\varsigma$.

15. *Suppl. I.* Limestone ashlar bearing an inscription in three lines.

Find place: In the field just south of the excavated area at Cholades in Soli. (The slab, found in 1936, was reported to the Cyprus Museum by the Government guard. Mr. Megow, the curator of ancient monuments in Cyprus, has kindly provided the Expedition with a cast of the inscription.) *Material and size:* Limestone. 23 × 66.

The letters are irregular. As to their shapes, the Λ with prolonged right *hasta*, and the

Ξ, should be noted, both in Attic inscriptions being used from the beginning of the Empire period; furthermore the italic M which occurs in Attic inscriptions from the 1st Cent. A. D. — It is impossible to ascertain whether there existed a sign between Λ and Θ in the third line.

Α Υ Ξ Η Σ Ι Χ Ρ Η Σ Τ Η
Χ Α Ι Ρ Ε Μ Η Λ Υ Π Ο Υ Ο Υ Δ Ι Σ
Δ Θ Α Ν Α Τ Ο Σ

Αὐξήσι· γρηγορή·
χαίρει· μή λυπόσ· σὺδεῖς (= σὺδεῖς)
ἀθάνατος·

Αὐξήσι] This name is not common and occurs mainly on some inscriptions: in Rome (*I. G.*, XIV, 1338); in Larissa, in Thessaly (*I. G.*, IX, 2, 860); in Telmissus, in Lycia (*Tit. Asiae Min.*, II, 1, 53), and one from an unknown place (*C. I. G.*, 6895). The name seems to be post-Classical.

Αὐξήσι γρηγορή· χαίρει] This very common formula occurs in Attic inscriptions “wohl nahezu ausschliesslich auf Grabsteinen von Sklaven oder unfrei Geborenen” (Larfeld, *Handbuch d. griech. Epigr.*, II, p. 856). On the said inscription from Larissa, a tombstone with this formula, ἀπελευθέρω is added to the name.

μή λυπόσ· σὺδεῖς ἀθάνατος] This formula, too, is often met with on tombstones — even if in some varieties. The phrase μή λυπόσ has previously been found only a couple of times, in Rome (*C. I. G.* 9589), and on two inscriptions in Egypt (*Revue des études grecques* VII, pp. 296). Θάρσει and εὐφύχει in the same sense are more common. Sieburg, who has dealt thoroughly with this formula in *Archiv f. Religionswiss.*, 8 (1904—05), pp. 397 ff., is of the opinion that the philosophy to which this formula corresponds, is met with in the Greek world, especially in stoicism and cynicism and that these schools of philosophy gave the impulse to the formation of the sentence in question. But under such conditions it is surprising that not one of all the Attic inscriptions has this formula. It is limited to certain localities: Rome (*I. G.*, XIV, 1531, 1536, 1560, 1634, etc.); Dalmatia (*Bulletino di arch. e storia dalmata*, 1903, p. 179); Cyprus (cf. below); Syria and Palestine (*Palest. Expl. Fund.*, Quart. Stat., 1911, pp. 57 f. — *Suppl. epigr. Gr.*, 2, 847. 7, 293.311); Egypt (cf. above), and Coptic tombstones (Cabrol-Leclercq, *Dict. d'archéol. chrét.*, 3:2, sp. 2877 f.). We may therefore be justified to assume that the formula originates in the eastern Mediterranean, and thence spread with those who went west, especially to cosmopolitan Rome. Cumont (*Les religions orientales*, p. 350) argues also, though with some doubt, that the formula is inspired by the Egyptian religion. It is worthy of notice that it is met with particularly on Christian and Jewish (cf. *C. I. G.*, 9917) tombstones.

In Cyprus, the formula is recorded from inscriptions, Cesnola, *Cyprus*, pp. 433 ff., No. 50 εὐφύχει· σὺδεῖς ἀθάνατος. 61 σὺδεῖς ἀθάνατος. 62. θάρσε(ι)· σὺδε(ῖς) ἀθάνατος, all from Larnaca. 101 εὐφύχει· σὺδεῖς ἀθάνατος from Idalion.

SOLI. THE THEATRE

9. *Soli*, No. 18.

Find place: Western parodos in the theatre. *Material*: Rhodian terracotta amphora handle. (Pl. CLXXX, 17).

ΕΛΑΝΙΚΟ Ἐλανίζου (sic).

A rose in the centre and the inscription around the upper part of the periphery. Ἐλανίζου an orthographic error for Ἐλλανίζου. Cf. Nilsson, M. P., *Timbres amphoriques de Lindos*, Copenhagen 1909, p. 419; Grace, Virginia, *Stamped amphora handles found in 1931—1932*, *Hesperia* III, 1934, p. 238, No. 87; for orthographic errors of a similar kind, cf. Nilsson, *op. cit.*, pp. 141 f.

ERIK EKMAN.

A P P E N D I X I V

CYPRIOTE SYLLABARY INSCRIPTIONS (Fig. 325)

VOUNI

1. *Vouni*, No. 164.

Find place: The temple of Athena. E. of Wall 7. *Material and size:* Square marble bowl, partly restored in gypsum. Size 24.5 × 24.5. (Pl. XLVII, 13).

Zo· va· li· o· se· o· ka· te· te· ke· i· tu· ka· i

Ζοφάλιος ὁ κατέθετο ἰ(ν) τὸ γλυκί.

The inscription reads from right to left. It is incised along two edges of the bowl. Half of both edges, probably with the name of the father and the deity to whom the bowl was dedicated, is missing. The name Ζοφάλιος occurs also on the coin, *Vouni* No. 294 v)2 (p. 249): pa· si· le· vo· se | zo· va· li· o·, *i. e.*, Βασιλῆφος Ζοφάλιω. It should be compared with Ζοφάτω (*J. H. S.*, XI, p. 66), Ζοφάλιω (*Swed. Cyp. Exp.*, II, p. 854, No. 7), Ζοφάριος (Lanckoronski, K., *Städte Pamphyliens und Pisidiens* I, Wien 1890, p. 180, No. 77), and [Ζοφάριος] (Lanckoronski, *op. cit.*, p. 181, No. 88). For names of this type cf. Sundwall, Joh., *Die einheimischen Namen der Lykier* (Klio, Beiheft XI), Leipzig 1913, p. 253. Their Anatolian origin is evident and they supply further proof of the cultural intercourse between Cyprus and Anatolia (cf. Persson, A. W., *More Cypro-Minoan inscriptions*, *Swed. Cyp. Exp.*, Vol. III, p. 601; Gjerstad, E., *Studies on pre-historic Cyprus*, Uppsala 1926, pp. 294 ff.; Vol. IV of *Swed. Cyp. Exp.*).

2. *Vouni*, No. 183.

Find place: The temple of Athena. W. of Wall 10. *Material and size:* Fragment of a bronze bowl.

. . . . se· o· ku· po· ro· ti· mo· a· ta· na· i· ka· te· te· ke· i·

. . . . ε ὁ Κυπροσίμω Ἀθάναι κατέθετο ἰ(ν) [τὸ γλυκί].

The inscription reads from right to left and is incised along the edge of the bowl. The donor's name is missing. The father's name belongs to the group of names compounded with κυπρο- as the first link: Kypragoras, Kyprophilos, Kyprokratis, Kypromedon, etc. (cf. *Swed. Cyp. Exp.* II, p. 858, No. 37). Ἀθάναι, dat. with *iota* (Collitz-Bechtel, *Sammlung der griech. Dialektinschriften* I, Göttingen 1884, p. 16, No. 17; Hoffmann, O., *Die griechischen Dialekte* I, Göttingen 1891, p. 47, No. 62); for Ἀθάνα, dat. without *iota* cf. Collitz-Bechtel, *op. cit.*, p. 31, No. 62 and Hoffmann, *op. cit.*, p. 74, No. 138.

3. *Vouni*, No. 226 a.

Find place: The palace. Room 45. On the floor. *Material and size*: Black Glazed bowl
Diam. 12.4. (Pl. LXXXIII, 11).

Most probably a Greek *kappa*, but a part of the bottom of the bowl is missing close to the sign, so that this may be incomplete.

4. *Vouni*, Tomb 1, No. 74.

Find place: In the chamber of the tomb, near the S. wall, at level +65. *Material and size*:
Terracotta pithos (Plain White VI). Height 51.0. (Pl. XCIX).

sa· ta· sa

Σασα-

The inscription is painted on the shoulder of the pithos, between the handles. Abbreviation of the owner's name, e. g. Σάσανδρος. Σασαγόρας. For similar abbreviation cf. *Swed. Cyp. Exp.*, II, p. 855, No. 21, where it can be completed to Σασαγόρας on the evidence of No. 20, found in the same tomb.

5. *Vouni*, Tomb 15, No. 1.

Find place: In the chamber of the tomb, near the W. wall, on the floor. *Material and size*:
Terracotta amphora (Plain White VI). Height 60.0. (Pl. CVIII, 2).

o· ni

Όνι-

The inscription is painted on the shoulder of the pithos, between the handles. Abbreviation of the owner's name, as No. 4 (e. g. Όνιδας), but the sign for the second syllable is rather worn and cannot be deciphered with absolute certainty.

6. *Vouni*, Tomb 16, No. 2.

Find place: In the chamber of the tomb, approximately in its medial axis, near the door,
at level +50. *Material and size*: Terracotta pithos (Plain White VI). Height 64.0.
(Pl. CIX, 3).

A. le· u· ko· sa·

a· ka· ra· to· se·

B. pi· ti·

A. Λευκό(ς) Σαλαμίνιος άκρατος.

B. Πιτι.

“White, Salamian, unmixed (wine). Drink (it)!”

Inscription A is painted in two lines on the neck to the left of the handle, and both lines read from right to left. Inscription B is painted on the neck above the handle, and reads from left to right, which is not surprising, as the inscription is written in the Paphian syllabary (cf. below) where the writing from left to right was very common, though not absolutely predominant as alleged by Hoffmann, *op. cit.*, p. 38 (cf. Meister R., *Die griechischen Dialekte*, II, Göttingen 1889, p. 192; Hill, G. F., *Catalogue of the Greek*

1 𐤀𐤀𐤆𐤄𐤅𐤆 𐤆𐤆𐤄𐤅𐤆 𐤅 𐤆𐤆 𐤆𐤆

2 𐤆 𐤆 𐤆 𐤆 𐤀 𐤆 𐤆𐤆 𐤆 𐤀 𐤆 𐤆 𐤆 𐤆 𐤆 𐤆 𐤆 𐤆

3 K 1 VHV

6 VΛΠΣ
𐤆 𐤆𐤅𐤆𐤆*

𐤅𐤆

5 𐤆𐤆

7 𐤆𐤆𐤆𐤆𐤆𐤆 𐤆𐤆𐤆𐤆𐤆𐤆

8 𐤆
𐤆𐤆𐤆𐤆
𐤆𐤆𐤆𐤆
𐤆𐤆

9 𐤆𐤆𐤆𐤆𐤆𐤆 𐤆𐤆𐤆𐤆𐤆𐤆
𐤆𐤆𐤆𐤆𐤆𐤆 𐤆𐤆𐤆𐤆𐤆𐤆
𐤆𐤆𐤆𐤆𐤆𐤆 𐤆𐤆𐤆𐤆𐤆𐤆

Fig. 325. Inscriptions Nos. 1-9 of Appendix IV.

coins of Cyprus in the Brit. Mus., London 1904, pp. 108 f.; cf. also Inscription A which runs from left to right but is written with Paphian signs, as shown below.)

The signs of the first line of Inscription A show no peculiarities and are clearly written. Λεωζός without ending *sigma*. This was sometimes dropped (Collitz-Bechtel, *op. cit.*, p. 12; Meister, *op. cit.*, pp. 252 f.; Hoffmann, *op. cit.*, pp. 204 f.) and very often when the following word began with a consonant (Hoffmann, *op. cit.*, p. 205). In this particular case, where the following word began with a *sigma*, the dropping of the terminal *sigma* in the preceding word is quite natural. The last syllable, *sa*, in the first row seems to be an abbreviation of Σαλαμίνος, which is abbreviated in this way or by the sign for *se*, i. e., Σελαμίνος (cf. Hoffmann, *op. cit.*, pp. 90 ff.; Hill, *op. cit.*, pp. CVIII, 65). Οἶνος λεωζός is mentioned in the ancient literature (cf. Billiard, R., *La vigne dans l'antiquité*, Lyon 1913, p. 512).

In the second line of Inscription A, the first sign is clearly the sign for *a*. The second and third signs resemble each other at first sight, but on closer inspection the differences become clear. The second sign has an oblique top line and the third sign a horizontal one; in the third sign the bottom line extends to both sides of the triangle above it, which is not the case in the second sign. The third sign is the typical sign for *ra*, and it is then impossible for the second sign to represent the same syllable, because that would give us a word with *-ra-*, and double consonants are never indicated in Cypriote syllabary. On the other hand, the second sign resembles the variety of the sign for *ka*, occurring in inscriptions from Paphos (cf. Meister, *op. cit.*, pp. 133, 144). The fourth sign is clearly a sign for *to*, and of the fifth sign enough is preserved to identify it with the sign for *se*. The reading ἄρατος may thus be considered as certain.

In Inscription B the first sign is the Paphian sign for *pi*, and of the second sign enough is preserved to identify it with the sign for *ti*. The imperative πιθῖ occurs also in an inscription on a terracotta askos (Collitz-Bechtel, *op. cit.*, p. 48, No. 135). The ending *-θῖ* is used in the verbs for eat and drink (cf. Hoffmann, *op. cit.*, p. 261).

7. *Vouni*, Tomb 16, No. 16.

Find place: In the dromos of the tomb, in front of the door, at level +130. *Material and size:* Terracotta pithos (Plain White VII). Height 45.5. (Pl.CIX, 3).

po· i· ni· ki· o· se· | ke· ro· | a· lu· su· to· se·

Φοινίκιος | κηρῶ | ἀλίπτος.

The inscription reads from right to left, is painted on the neck of the pithos, as the preceding one. There are vertical lines as divisors between the words. The first and second words are moreover written some distance apart. The inscription refers to the contents of the pithos and tells us that the pithos contained οἶνος φοινίκιος, i. e., φοινίκιος (Diodor. I, 91,5: ἀλόξων οἶνον φοινικεῖον; Suidas: Φοινίκιος οἶνος), date-palm wine. We know that the date-palm grew in Cyprus in ancient times (Holmboe, J., *Studies on the vegetation of Cyprus*, Bergen 1914, p. 336). Palm-wine was known and appreciated in the Orient (Joret, Ch., *Les plantes dans l'antiquité et au moyen âge*, Paris 1897,

pp. 408 f.). Κηρῶ ἀλοστῶς: smeared with wax. Κηρῶ. dat. without *iota*; ἀλοστῶς is an orthographical error for ἀλοστῶς, verbal adjective of ἀλο-γω. with τ- infix (cf. Kühner-Blass, *Ausführl. Grammatik d. griech. Sprache*, Hannover 1890-92, II, p. 290; Chantraine, P., *La formation des noms en grec ancien*, Paris 1933, p. 305; a good parallel, with similar meaning, is γρη-στῶς). Ἀλοῶ is a synonym for ἀλείφω (Hesychius: ἀλοῶν· ἀλείφειν). The orthographical error, ἀλοστῶς instead of ἀλοστῶς, brings further proof of the confusion of τ and ρ already in the 4th Century B. C. (cf. Kühner-Blass, *op. cit.*, I, 70). Κηρῶ ἀλοστῶς refers to the tightening of the vessel by covering its inside with wax. Pitch was very often used for this purpose (Blümner, H., *Technologie und Terminologie d. Gewerbe u. Künste b. Griechen u. Römern* II, Leipzig 1879, pp. 351 ff.; Billiard, *op. cit.*, pp. 474 ff.), but wax was also made use of for the same purpose (*Geoponica*, VI, 7, 2). The use of the latter material was considered to be a more refined method and that is the reason why it was indicated in the inscription.

MERSINAKI

8. *Mersinaki*, No. 751.

Find place: Temple-site at Mersinaki, Square D 15, at level 31.5. *Material and size*: Block of soft, grey limestone in the shape of a truncated pyramid. Height 60.5. Width 20.5. Thickness 21.0. (Pl. CXLVIII, 6).

.... se
ka· te· te·
ke· i· tu·
ka· i·

.... ε καταθήκη (ν) τῶν αἰ.

The inscription reads from right to left and is incised in four superimposed lines on the upper half of one side of the block. Of the name of the donor only the terminal syllable is clearly visible. The name contains three syllables, of which the first may be the sign for *o* and the second the sign of *na*, and in that case the name would be Ὀνάς, which is represented on other inscriptions in Mersinaki (cf. Appendix III, p. 622 and Appendix IV, No. 9).

9. *Mersinaki*, No. 1100.

Find place: Temple-site at Mersinaki, Square M 24, at level 11.0. *Material and size*: Rectangular base for statue of hard, grey limestone. Length 17.3. (Pl. CXLVIII, 8).

o· na· se· o· ki· li· ka· vo· se·
ka· te· te· ke· to· a· po· lo· ni· i· tu·
ka· i· to· i· te· o· i·

Ὀνάς ὁ Γιλ(λ)ιζαφός καταθήκη τῶν θεῶν τῶ Ἀπῶλ(λ)ων (ν) τῶν αἰ.

The inscription reads from right to left and is incised in three superimposed lines on one side of the base. For the name Ὀνάς, see Appendix III, p. 622. Γιλ(λ)ιζαφός was a common

name in Cyprus; it is Phoenician, with Greek ending (Meister, *op. cit.*, p. 233). It can be seen on Pl. CXLVIII, 7, that the signs for $\tau\omega\epsilon\ \theta\epsilon\omega\epsilon$ are incised immediately below those of $\tau\omega\ \text{Ἀπελά(λ)ων}$ at a considerable distance from the terminal signs of the third row and not aligned with those. Evidently the signs for $\tau\omega\epsilon\ \theta\epsilon\omega\epsilon$ are not incised in their proper place. When the name of the god and $\theta\epsilon\omega\epsilon$ as an attribute have the definite article the attribute is always placed before the name of the god (cf. Hoffmann, *op. cit.*, p. 294) and $\tau\omega\epsilon\ \theta\epsilon\omega\epsilon$ should therefore be incised in front of $\tau\omega\ \text{Ἀπελά(λ)ων}$. Apparently the person who made the inscription forgot to incise the signs for $\tau\omega\epsilon\ \theta\epsilon\omega\epsilon$ in their proper place, and therefore added them subsequently immediately below the signs for $\tau\omega\ \text{Ἀπελά(λ)ων}$ as a sort of indication where the attribute should be inserted.

E. G.

A P P E N D I X V

ANTIQUITIES IN THE MINES OF CYPRUS

By J. L. BRUCE

in Collaboration with

C. P. Manglis and D. M. Creveling

At the request of Dr. Einar Gjerstad I am glad to add to the record of the Swedish Cyprus Expedition by describing antiquities found in the mines of Cyprus. The Cyprus Mines Corporation, of which I am Resident Director, has been the most active element in the reopening of the ancient copper mines and, consequently, has had good opportunity to gather data of this nature.

In the preparation of this chapter I am indebted especially to Mr. T. A. Rickard, Dr. Joseph Walsh, Mr. Geo. Chr. Pavlides, and the records of the late Mr. V. G. Hills for writings from which I have given liberal quotations, and to Mr. C. P. Manglis and Mr. D. M. Creveling for their willing collaboration and for descriptions and photographs, which I gratefully acknowledge, as I do the assistance given by Mr. H. A. Storm. In Cyprus the evidences of ancient mining operations are prominent and plentiful. Literature, however, appears to contain relatively few references to the production of metals and no comprehensive or illuminating descriptions of mining or metallurgical operations.

The most accurate and most detailed account of ancient mining activities comes through the writings of Galen, translated into English¹ by Dr. Joseph Walsh M. D. of Philadelphia. These and other writings have made it quite certain that, in addition to copper, the Romans produced zinc oxide and a variety of natural minerals and artificial caustic and astringent salts of copper, iron and sulphur, and no doubt unrecognized mixtures of such minerals and salts. These were used in medicine and in the arts.

I quote parts of Dr. Walsh's translations:

"The mines [Galen] visited were at Soli² where Solon, after whom it was named, gave counsel and Aratus, the poet astronomer, was born. Though interested in these two illustrious men she produced and fostered, Galen becomes absolutely enthusiastic over the mines, and not only carried away enough of copper and other minerals to last him thirty years, but presented some to his friends in Pergamum and Italy, and they considered it the greatest gift (XII, 220) . . .

"He describes (XII, 238) the collection of copperas water and the making of chalcanthos: 'There was a large low house sheltering the ingress into the mine. It was dug into the hill



Fig. 326. Skouriotissa. Ancient slag heap on the slope of the Foukassa Hill.

like a cave, in width so that three men touched, in height so that the tallest could walk upright, and on a slight incline. At the bottom, about 600 feet from the entrance, there was a lake of tepid, thick, green, greasy water. Throughout the descent the temperature was about the same as that in the first room of the bath, ordinarily called the promalacterion.'

'The water dripping from the porous hill drop by drop is collected throughout the twenty-four hours in Roman amphorae (Fig. 327). Slaves carried it out and poured it into square earthenware troughs located at the entrance of the house, where after a few days it thickened, and chalcantnos (iron sulphate)³ was made. At the bottom of the mine the odor is suffocating, and is tolerated with difficulty. The water has a similar taste. The slaves nude carried the jars with the greatest haste in order not to remain long in the mine. There were lights at moderate intervals, but they extinguished frequently. The mine was excavated little by little by the slaves over many years. When the dripping water begins to lessen the slaves dig further into the hill.'

'This description of the well-known Cyprian copper mines and their products is the lengthiest and most detailed in extant writings, as well as the last mention of them for sixteen hundred years until the lament of the traveller Constantius⁴ in 1766 that they are no longer operated . . .

'We have writings on Cyprus from 985 A. D. until the present time, and it is quite evident from their failure to mention copper that none was produced. It is practically certain that operation ceased between 364 and 700 A. D. during the upheavals occasioned by the division of the Roman Empire into East and West, the invasion of the Goths and the Huns, the Persian conquests of the Eastern Empires, and the Mohammedan triumphs. It is possible that this may be defined within narrower limits to the age about 400 A. D. when Cyprus was almost depopulated by a series of misfortunes. It was conquered by a fleet from Constantinople, earthquakes destroyed numerous towns, and, according to tradition, no rain fell for thirty years . . .'



Fig. 327. Skouriotissa. Fragments of amphora used for carrying water from the ancient mine.



Fig. 328. Mathiati. Fragments of bronze ingot smelted to a shape suitable for transport.

Dr. Walsh's translations have been quoted at greater length in connexion with the mines of Cyprus by Mr. T. A. Rickard⁵ and the late V. G. Hills.⁶

Mr. Rickard's paper correctly credits the resumption of active mining operations in Cyprus in modern times to the "initiative of the late C. Godfrey Gunther, an American mining engineer and a graduate of the Columbia School of Mines", and states,

"In 1912 Mr. Gunther was engaged in a systematic examination of the ancient mining districts of the Near East, and his attention was drawn to Cyprus by the mention of the island in books of travel as a source of copper in ancient times. His search was financed by my friends Seeley W. Mudd and Philip Wiseman, of Los Angeles, California.

"[One of] the mines, six miles distant, is close to the old monastery of Panagia Skouriotissa. This monastery, about two hundred years old, has a little church (Orthodox Greek) in which are many quaint ikons and lamps ever burning with smokeless olive oil. . . . Panagia Skouriotissa means 'Our Lady of the Slags', a Greek name, the origin of which is seen in the black



Fig. 329. Skouriotissa. Blocks of "Roman" slag, each a single pour from smelting furnaces.



Fig. 330. Skouriotissa. Crystal of *selenite*, 8 inches long, from open underground mine.

hillocks of vitreous refuse from smelting [slag] that extend along the foot of Foukassa Hill, just above the monastery. At a slightly higher level is some red slag, coarse and full of clinker, which is imputed to the Phoenicians⁷ as, with greater assurance, the later slag, black and much more plentiful, is credited to the Romans."

The most striking evidences of ancient mining operations in Cyprus are the large slag heaps, consisting of the refuse from smelting operations which were conducted on relatively large scale at the four principal localities previously mentioned and on smaller scale at 30 or 40 other places on the island.

The ancient slag heaps at Skouriotissa (Fig. 326) and Mavrovouni are estimated at more than two million tons and there is at least as much scattered over the island at other smelting sites.

These slags may be generally classed into two categories, the oldest of which is assumed to have been produced by predecessors of the Romans. These are distinguished from the later slags by their reddish-brown colour, higher iron content and more advanced stage of decomposition. Their location and size, as well as their appearance and state of decomposition support the supposition that they are older than the Roman slags, which are dark-brown approaching black, lower in iron content and very much less altered by their long exposure to weathering and oxidizing influences. Many pieces are hard, compact and apparently almost unaltered since time of production.

Both types of slag contain occasional pellets or "shots" of metallic copper and inclusions of matte-like material. They have numerous gas holes, some of which now contain small crystals of gypsum which are assumed to have been deposited by lime-bearing surface waters subsequent to the smelting operation. Large quantities of these slags have been removed as road metal.

Strangely enough, no substantial remains of the smelting furnaces have been found in

place, though scattered through the slag piles are stones and pieces of fused clay, apparently remnants of discarded furnaces. Many blocks of slag of similar size and shape and weighing from 75 to 100 pounds have been found. These resemble that half of a volcanic lava cone which can be seen from one side, and having the peak on one side indicate that the slag has been tapped or skimmed from the furnace at that point. The surfaces of the blocks are made up of small congealed rivulets, ridges or ribbons of slag, and the blocks taper from 8 or 10 inches in thickness at the apex of the cone segment to 1 or 2 inches at the base (Fig. 329). It is probable that each block would represent refuse from the production of only 4 or 5 pounds of copper.

Typical analyses of Skouriotissa slags are as follows:

CHEMICAL ANALYSIS OF SLAGS

Sample No.	"Phoenician"					"Roman"					Typical Modern Slag
	1	2	3	4	5	1	2	3	4	5	
	%	%	%	%	%	%	%	%	%	%	
Cu.....	0.80	0.78	1.25	0.2	0.2	0.84	0.68	0.6	1.1	3.1	0.3 to 0.4
Fe.....	52.98			51.9	56.1	15.54				14.7	
FeO.....		32.9	54.0				36.00	36.1	23.8		36 to 44
Fe ₂ O ₃		32.2					9.00				
S.....	1.54	2.3				2.30	1.26				1.2
MnO.....	0.24	0.07	10.5	0.8	9.6	29.30	6.21	22.8	39.5	49.5	
CaO.....	1.20	1.76	1.3	1.2	1.0	2.50	4.18	5.3	2.8	1.1	10 to 16
MgO.....	0.51	0.20				0.47	1.65	3.6			
Al ₂ O ₃	0.20	2.98	3.8			4.60	6.42	9.4			
SiO ₂	21.50	19.54	18.1	16.4	13.6	23.10	29.33	31.5	17.4	29.3	
Zn.....	0.14	0.30				0.10	0.50				
Ag, oz/Ton.....		0.17					0.08				
Au.....		0.08					trace				

Some remarkable characteristics of these slags, when compared with those produced by modern smelting practice, are:

1. Low silica, lime, alumina and magnesia content.
2. High iron content of "Phoenician" slags.
3. High manganese content of "Roman" slags.
4. From above analyses, and a number of others not listed above, it appears that "Phoenician" slags usually contain about 50% more iron than "Roman" slags at the same locality.
5. Low copper content, which is often less in "Phoenician" slags than in "Roman" slags.
6. High percentage of ferric iron, especially in "Phoenician" slags.
7. Substantial sulphur content.

With respect to above it is well to have in mind the nature of the ore that is now being mined by the Cyprus Mines Corporation from the Skouriotissa mine at which the above slag samples were taken. In the past few years about 2,000,000 tons of ore have been shipped with analysis differing very little from the following:

Copper	2.3 %
Sulphur	48.0
Iron	42.0
Alumina	1.3
Silica	1.8
Lime	Trace
Magnesia	Trace
Oxygen	4.0

The ore is essentially a massive cupreous pyrite with almost no siliceous gangue. It differs radically from most pyrites, however, as the copper and iron have been to a remarkable extent converted to sulphates.

I suspect that the considerably sulphated ores were more easily smelted by the ancients. The theory that they were looking for rich *sulphated* copper ore affords a better explanation of their extensive meanderings through a large, badly ventilated and gaseous orebody than does the theory that they were looking for rich copper ore. It is possible that most of the sulphating has occurred since the beginning of mining operations, though there are many indications that this is not the case. There is also much evidence that the ancients did not produce copper in Cyprus on any important scale from carbonate, silicate or oxide minerals of copper. It is almost impossible to find hand specimens of such minerals, of commercial tenor, and it is not conceivable that the ancients could have exhausted them so thoroughly that the very extensive modern workings would be unable to disclose some that they had overlooked.

The origin of the silica in all slags, and the origin of manganese in the "Roman" slags are mysteries that have not been satisfactorily explained. Samples of "Phoenician" and "Roman" slags were sent to the Colorado School of Mines in 1928. Mr. Irving A. Palmer, Professor of Metallurgy, reported on them as follows:

"I am inclined to think that the ores were roasted before smelting, but not completely. Presumably the method was that of heap roasting. It would be very difficult to obtain a complete or 'dead' roast in that manner; it would take a very long time and would involve the formation of copper sulphate. The latter is very soluble in water, and a considerable proportion of the copper would be lost in wet weather. That was the result in Ontario, Canada years ago, when the Canadian Copper Company used heap roasting on its high sulphur copper ores.

"Another reason for believing that the ancient metallurgists did not give their sulfide ores a dead roast is the low percentage of copper in the slags. It is found that in smelting oxidized copper ores a considerable amount of copper goes into the slag as copper silicate, (CuSiO_3). In the early days of copper smelting in Arizona, when practically all of the ores were oxidized, the copper in the slags sometimes went as high as three or four per cent. It is difficult, even in modern times, to get it down to one per cent. In smelting sulfide ores, the copper is combined with sulfur as copper sulfide, CuS_2 , and does not go into the

slag as silicate. Copper sulfide, however, is slightly soluble in liquid slags, and most modern copper slags contain from 0.30 per cent to 0.45 per cent copper.

“My own opinion is that the Phoenician and Roman metallurgists gave the ores a partial roast, much as we do to-day, and then smelted the product. Enough sulfur was left in the roasted ore to combine with all of the copper and some of the iron. The smelting then resulted in two products, matte and slag. I rather think that the matte was then treated by a process similar to that later on used by the Welsh metallurgists at Swansea, Wales. In this process the matte is first subjected to a roasting operation in a reverberatory furnace, converting practically all of the iron sulfide into iron oxide and a part of the copper sulfide into copper oxide. The furnace doors are then closed and the temperature raised. The following reaction then takes place:

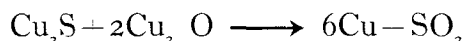

“Enough silica is added to flux the iron oxide and make a fusible slag. This method is known as the ‘Roasting-Reaction Process’ and has been extensively used in the smelting of lead ores as well. Briefly, it consists in roasting a part of the sulfides to oxides and then allowing the oxides so produced to react upon the unaltered sulfides. The result is a reduction of both sulfides and oxides, as shown in the above equation. The slag made in this process would very likely have some shots of metallic copper contained in it. It is probable, also, that this slag would be allowed to accumulate for a time and then be given a special treatment in a hot furnace.

“It is impossible to say whether or not any black copper was smelted from oxidized ores. As stated above, however, the low copper content of the slags remaining would seem to indicate that sulfide ores rather than oxidized ores were smelted.

“I believe that the manganese found in the slags was accidental, rather than a result of deliberate planning on the part of the ancient metallurgists. It is quite probable that these metallurgists knew of the fluxing properties of manganese oxides, but the amount which they used would hardly give them convincing proofs of the value of manganese as an agent for increasing the fluidity of slags. Manganese oxides are helpful in smelting ores that have been poorly roasted because the excess oxygen contained in the former helps to burn up the sulfur in the latter. The lead metallurgists of Colorado used to prize the Leadville manganese ores for this reason, as well as for their influence upon the liquidity of the slags.

“The ‘Phoenician’ slags evidently became oxidized since they were formed. Ferric oxide cannot combine with silica to form a slag. In the furnace the Fe_2O_3 or Fe_3O_4 is reduced to ferrous oxide, FeO , by the carbon in the coke or charcoal, and then the FeO unites with the silica. Below are the reactions:

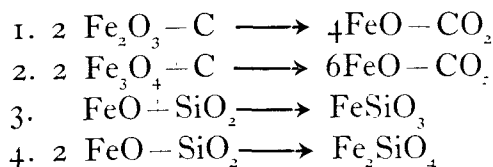

Both types of silicates are formed and both are quite fusible.

"I have never seen a slag that has been oxidized to such an extent as the 'Phoenician' slag. It looks as if the slag had not been completely melted at the time it was made, and was, therefore, somewhat porous, so that it would oxidize more readily. This phenomenon, I believe, has been seen in some lava overflows. The solid lava contains many pores and later on becomes susceptible to oxidation. A slag that has been thoroughly liquid solidifies into a very hard and dense mass and resists the action of oxygen for a long time.

"The manganese is present in the slags as manganous oxide combined with silica and it should have no effect upon the state of oxidation of the iron."

The only ores of copper that are known to us at Skouriotissa are, of course, not at all self-fluxing, nor do they approach that condition. The scarcity of silica rock of suitable character for satisfactory fluxing within 20 or 30 miles of the ancient mines of Soli (Skouriotissa and Mavrovouni), Amathus and Tamassus is notable to such an extent that Cyprus Mines Corporation engineers were sent as far afield as Egypt, Syria, and Greece to locate deposits that would be suitable for smelting operations. These were finally located in quantity in Cyprus but at some distance from above named ancient mining centres.

It is a fact that there are somewhat limited occurrences of silicious rock of moderately satisfactory character for fluxing. These lie under the oxidized extensions of the pyrites orebody and extend beyond them as outcroppings which have been exposed by partial erosion of the large deposit of Raimondite ($2\text{Fe}_2\text{O}_3 \cdot 3\text{SO}_3 \cdot 7\text{H}_2\text{O}$) which remains as an oxidation product of that portion of the pyrites orebody which has been uncovered by erosion of the umber-marl-limestone capping. Nature was kind to the ancient smelterman as the silica rock is without much doubt a highly altered pillow lava which has had almost all non-silicious constituents leached out by the acidulous solutions resulting from pyrites alteration, and the remaining silica recemented and strengthened by deposition of chalcedony. Except for this the smelterman would have had to go far afield for his silica rock. This carries practically no copper. The unaltered pillow lava from which it is derived contains only about 50% SiO_2 with 2.0% Al_2O_3 , 3.0% CaO , 10% Fe_2O_3 , 6% MgO .

From where did the manganese come for the "Roman" slags and why was it used? There is practically no manganese in any of the copper, gold or silver bearing ores, and no valuable gold, silver or copper values have been found in the umber deposits that occur in many places in Cyprus. At the Skouriotissa mine there are umber deposits of considerable size lying almost immediately over the sulphide orebody and in some places in direct contact with it. At first sight it seems obvious that the manganese and perhaps the silica in the slags came from the umber. The following facts contradict this theory, however:

- (A) In 14 samples of Cyprus umber, of which 7 came from the Skouriotissa mine, only one contained more than 8.5% manganese, the average being 7.3%. This compares with slag analyses most of which exceed 15%.
- (B) In above umber samples the iron content was more than 30% with the exception of 5 samples in which the average was 25%. The average of all samples was 31.5%. This is more than we find in "Roman" slags.
- (C) "Insoluble" content of umber samples was less than 21% except in 4 samples which

averaged 27%. General average was 20%, and silica must have been less than 20%.

(D) Average assay of 7 samples from Skouriotissa mine:

MnO ₂	13.0 % = 8 % Mn
Fe ₂ O ₃	38.4 = 27 % Fe
Al ₂ O ₃	10.8
Insoluble	22.3
CaO	1.0
MgO6

(E) At several ancient Cyprus mining sites where typical high manganese "Roman" slags are found there is no umber in contact with the orebody.

The above seem to demonstrate clearly that the manganese and silica in "Roman" slags did not come by accident, or by design, from any umber that formed portions of the orebody or that lay in contact with it. Richer manganese ore was evidently brought in from isolated Cyprus deposits not in contact with ore, or from outside sources. The addition of ordinary umber would probably not have improved smelting. With good clean umber which contains about 9% manganese it would have required at least as much umber as ore in order to get slags carrying 4.5% Mn. In many places the "Roman" slags carry more than 20% Mn. The manganese must have been added in the form of richer manganese ores with a specific purpose in view. This probably was to make slags more fusible, but may well have been for other reasons not yet understood.

"Phoenician" slags being much higher in iron content than "Roman" slags indicates that much less slag was produced per ton of ore smelted, if it is assumed that fluxes were low in iron content and that ore of similar iron content was treated. The similarity in copper content of the two types of slag indicates that the Cypriotes in pre-Roman times made about as good percentage of copper recoveries as in the Roman period. This does not seem probable, however, and I have come to the conclusion that the present copper content of Cyprus slags (and of ancient slags in Spain and elsewhere) cannot be assumed to represent copper content at time of production. It is probable that oxidation and leaching by rain-water have greatly reduced the content, especially in the case of the older and more decomposed "Phoenician" slag. The high percent of ferric iron in this slag indicates great alteration, as the iron must necessarily have been in the form of ferrous iron at time of production.

The position of the so-called "Phoenician" slag at Skouriotissa and its irregular surface indicate that the later operators may have removed and resmelted the richer portions.

In spite of sparse vegetation and arid conditions which have promoted rapid erosion and obliteration of many of the ancient surface cuts and openings, there are several sites where it is obvious that ores were sorted, broken and otherwise prepared for the smelterman. At one site on the Mavrovouni property we were considerably mystified by a well-mineralized outcrop showing secondary enrichment and commercial values and apparently overlying pleistocene clay sedimentaries that are assumed to have been deposited after formation of

the orebody. This on close investigation was first identified as the oxidized remnants of an ancient sorting dump. Subsequent investigation, however, disclosed the fact that there had been ancient galleries in the sedimentary formation running only a few feet beneath the "outcrop". At several other points on the island I have observed superficial iron oxide deposits and staining of the pillow lava formation, together with slight indications of oxidized copper, beneath which have been found ancient galleries showing no evidence of having produced commercial ores. At first these were thought to have been injudiciously selected prospects, but I have now come to the conclusion that they are probably the sites of roasting "heaps" to which the introduction of air was facilitated by these shallow underground galleries.

In two places beneath iron-stained outcroppings we have discovered uniform sized pieces of unmineralized stone forming a porous bed having a large percentage of voids. The pieces have been cemented together by iron oxides carried down from the overlying "outcropping". It seems probable that these beds represent artificial bases constructed for better admission of air to overlying roasting heaps.

Some places show strong indications of having been worked as opencasts or opencuts and there are still a fair number of ancient openings leading to underground shafts or galleries; in other places the ancient underground galleries have been entered through modern excavations.

Nothing of importance has been found to date indicating that there was any plan or campaign followed by the ancients for locating or orienting galleries or stopes in the ore. The overseers probably left much to chance and to the judgement of their slaves, with instructions to concentrate activities on the richer and better ores. In a number of instances cores of reconsolidated ancient waste filling have been encountered during modern mining operations in ore. In some cases the reconsolidation of waste has been so complete as to form a hard rock rib of waste in ore. These ribs have been identified as filling only after finding particles of foreign matter such as wood, or charcoal remnants of wood, pieces of baskets or occasional iron tools that have been protected from corrosion by being tightly embedded in impervious clay-like waste. In a few places there have been found supporting walls of sun-dried mud bricks or surface-quarried stones. Most of the ancient "filling" is in small ribs and not in massive blocks. This indicates that filling was placed in old pre-existing galleries as a convenient means of getting rid of it and not as part of a program for supporting the ground in galleries and stopes as in modern practice.

In nearly all cases where walls have been built these appear to have been for the purpose of giving support to roof and sides which had already caved as the result of making unsupported excavations too large and not for the purpose of giving support to roof or to filling placed as part of any systematic stoping plan.

Galleries differ considerably in size and shape (Fig. 376). In the hardest rock and in heavy, soft ground galleries have been chipped out to the smallest practical cross section, about 28 inches to 30 inches wide by 4 feet high, with sides slightly bowed to give narrower width at top and bottom. In softer rock and in stronger ground, galleries may be as much

as 5 feet 6 inches or 6 feet in width by 6 feet in height. Inclination of floor varies from horizontal, to about 30 degrees from the horizontal, with a very limited number of vertical shafts. The steeper inclines, which obviously were used principally for gaining elevation, are in many cases of irregular spiral shape.

Rough steps have been cut in many of the inclines and many galleries have small recesses cut on one or both sides at the elevation of the waist line of a man of average height. These usually consist of a relatively flat shelf with sides and roof of recess sloping downward to the shelf from the wall of the gallery. The shelves usually occur at intervals of 5 or 6 feet along the gallery and it is assumed that they were used for support of small lamps as driving of the gallery progressed. In most cases no smoke has been observed on the roof or sides of such recesses. This may be due to the relatively small amount of smoke given off by such lamps when burning olive oil, or it may indicate that these recesses were used as handholes to assist the miner in making progress along the gallery or incline. The recesses are more generally observable in inclines.

In a number of places on the island I have observed ancient adits driven horizontally from relatively low points in such manner as to show that such adits were driven for the purpose of drainage. From these adits, and from others, apparently driven for the purpose of extracting ore, there are frequently to be found inclined raises driven to the surface, perhaps for ventilation, as the adit advanced. At Kalavasso there is such an adit which has been re-opened for a distance of 1250 feet from the portal, which was permanently supported by stone walls. This gallery is driven entirely in pillow lava without any sign of mineralization. Above the point to which it has been re-opened there is on the surface a steep incline of exceptionally large dimensions dipping toward the adit. It is presumed that the incline was made for the purpose of extracting the ore, as the entrance of the incline is near large slag piles. The size of the incline suggests that some kind of machinery may have been used, either for de-watering or ore hoisting, but no remains of such machinery have been found.

On the walls of some of the ancient galleries which have been filled with water, large crystals of selenite (hydrous CaSO_4) were found. It is obvious that these have crystallized from waters bearing calcium sulphate since the Roman galleries were abandoned (Fig. 330). One of the largest crystals found was about 9 inches long by $1\frac{1}{2}$ inches by $\frac{3}{4}$ inch. This crystal completely surrounded a long narrow pocket of water with an included air or gas bubble which can easily be seen as the air bubble travels when the inclination of the crystal is changed.

Almost all of the ancient mine timbers within the boundaries of the cupreous iron pyrites orebody have been converted to charcoal from which volatile matter has been almost completely expelled, so that it is difficult or impossible to get a flame of combustion. The grain of the wood has been well preserved. In nearly all cases in which wood has been found within the boundaries of the orebody, it has been intimately surrounded by ore, indicating failure and caving of the galleries in which timber was placed. When timber has been in the pillow lava waste country rock outside the boundaries of the orebody it has been surrounded in some cases by loose waste rock in other cases by partly reconsolidated rock, and in many instances

it has been in wide open galleries. Such timber is of various kinds, shapes and sizes, depending to some extent on the nature of the opening it was intended to support. Though most of this timber is more than 1700 years old, it is in many cases very well preserved, no doubt on account of exclusion of air by submergence in mine water, which in itself is a good preservative as a result of the presence of copper sulphate.

In several cases thin sheets of metallic copper have been precipitated throughout the timber, usually along planes radiating toward the heart of the tree. In a few cases the copper has been precipitated in the wood in dark-blue or black specks which appear to be the mineral covellite (CuS) or the mineral chalcocite (Cu_2S) or a mixture of these two.

Mr. D. M. Creveling, Superintendent of Mavrovouni Mine, observes:

"The greatest concentration of copper is nearly always at knots in the timber, and numerous times when cutting timber with copper in it a strong smell of pitch has been noticed. From this it is assumed that . . . pitch promoted the deposition of copper.

"The amount of copper in different pieces of timber varied greatly. In some pieces copper penetrated only $\frac{1}{4}$ to $\frac{1}{2}$ inch from the surface, in others one inch or more, and in still rarer cases it penetrated to the centre. In one case the copper was found in about two-thirds of the section while the other third had no copper. The line of demarcation between the two is nearly straight. In every case where the bark was still on timber containing copper, there have been found globules of copper between the bark and the wood.

"By far the most common timber used by the ancient miners was pine, probably Aleppo Pine (*pinus halipensis*). Next in amount discovered was plane tree, probably Eastern Plane (*platanus orientalis*). A few pieces of alder, perhaps Eastern Alder (*alnus orientalis*), have been found, also some of Oak, probably Dwarf Oak (*quercus alnifolia*) and one piece of walnut (*juglano?*)."

According to Mr. Creveling, a count of growth rings showed timber ranging in age from 11 to 52 years at the time it was cut. He thinks the timber was prepared for use by cutting with adze-type tool, as distinguished from one shaped like an axe. Marks on timber indicate cutting edges of from 2 to $3\frac{1}{2}$ inches in width.

With regard to methods of mining used by the ancients, Mr. Creveling states:

"It is nearly impossible at this time to say definitely what system or systems were used. Where the mining was extensive the ore was found to be so badly caved as to give little indication. Where open stopes have been found, it was necessary to fill them, due to their proximity to present workings, instead of investigating.

"To date evidence points to something similar to a room and pillar system in which as much ore as could safely be recovered by leaving intervening pillars was taken out. When these pillars would no longer support the weight of overlying ground, the region was abandoned and allowed to cave, and new stopes were started in other places. In some cases the stopes apparently were back-filled with waste rock so that the pillars previously left could be removed also, but there is no evidence that this practice was extensive. More filling is encountered in the western portion of the orebody than in the other parts, and a sample taken from one of the pillars assayed 9.6% Cu.



Figs. 331—332. Mavrovouni. Ancient underground galleries with timber supports.

“The surface contours near the outcrop of the orebody indicate some opencast work. It is quite probably that as much ore as possible was mined by opencast and that underground mining was then resorted to. The surface elevation at this point is about 600 feet above sea-level, and the lowest point at which ancient workings have been found is about 250 feet above sea-level. Modern development work at this time reaches 200 feet below sea-level.

“The disposal of water must have been a big item to the ancient miners, and it would be thought that they could not have mined much below the level of an adit driven from the nearest low point on the surface. This is not the case, however, as their nearest point on the Marathassa river has an elevation of 450 feet above sea-level, or 200 feet above their lowest working so far encountered. How the ancients handled the water of this 200 feet is a question, as no traces of pumps have been found.”⁸

“The first working found underground was an inclined stairway that later was followed 160 feet on the incline from an elevation of 320 feet to 393 feet above sea-level (Fig. 377). This had been cut about 5 feet 6 inches high by 2 feet 7 inches wide and extended both upward and downward from the points to which it was followed. The slope averaged 35°. Three flights of steps were encountered, having a tread 12 inches by 8 inches high, and it is thought that there were steps throughout at one time, which were either worn down or have sloughed off since the mine was abandoned. For the most part the rock, altered pillow lava, was hard and had not been timbered. Two sets, however, were found still standing where the rock was softer. There were occasional niches in the walls which probably were used as hand holds, being too small to hold a clay lamp.

“In the upper parts of the orebody no workings were found that had not caved or been

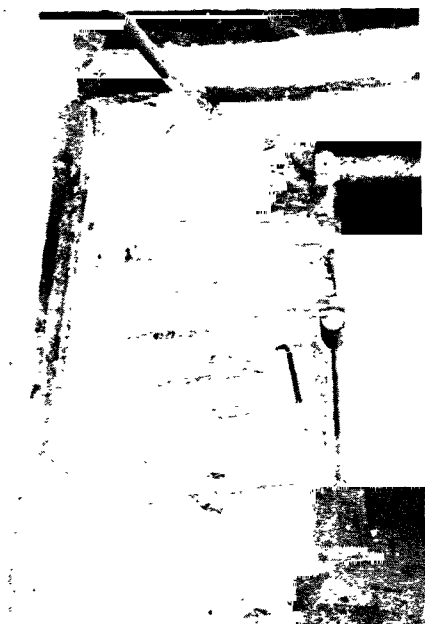

Fig. 333. Outside view of ancient square crib-timbered vertical shaft.



Fig. 334. Mavrovouni. Ancient un-timbered gallery.

filled by material that had caved from above. Many pieces of timber were found. To the S. of the orebody open workings, timbered and un-timbered, were encountered, in many of which the timber supports were standing in place. It is remarkable that these timbers still held the ground up over 1800 years after they had been stood by ancient miners (Figs. 331—333). A vertical cribbed raise was also found, to which one of the drifts connected. The cribbing was as sound as the day it was placed (Fig. 333). A second cribbed raise was encountered 100 feet lower, 345 feet N. and 36 feet E. of the first one, which was 400 feet above sea-level.

“At 250 feet elevation, where fewer ancient workings were in evidence than at higher levels, the first open stopes were found, three in number. The first was 48 feet long and 8 feet wide, the second 16 feet long and 9 feet wide, and the third 28 feet by 7 feet. Each was about 7 feet high. The ends of all three were caved and they were probably longer than the figures given.

“With regard to materials and tools used by ancient miners, no objects of metal have been found at Mavrovouni mine. This is no doubt due to the fact that all iron was replaced by the copper in solution in the mine water. Present mining practice indicates that it was impossible for some tools not to have been lost, but no wooden handles have been found that could positively be identified. With Cyprus’ wealth of copper, it hardly seems possible that the island did not produce considerable of the copper used in this part of the world in the making of bronze.

“It might be worth while at this point to list the different objects used by the ancient miners which have been found, and then describe each in detail.”



Fig. 335. Upper ends of four types of ancient post supports.



Fig. 336. Types of posts showing "horns" which prevented capping timber from sliding off.

Posts, used to support caps of drift sets and as a form of T-piece in stopes.

Caps of drift sets.

Lagging, both side and top.

Wedges.

Cribbing, used in raises or shafts.

Ladders.

Hand windlass.

Rope.

Piece of trough or launder.

Dowelled boards.

Scrapers.

Stakes.

Pieces of basket.

Pieces of pottery, water jugs, and lamps.

Stone "foot-board."

"Probably the most numerous of the finds of timber have been posts. This is due to the fact that they were used both in drift sets and to support the backs of stopes. Every post found has one characteristic in that the top was bevelled on both sides to give a more knife edge top than if the top had been left round. The reason for this probably was that the posts required longer pieces of timber than the caps and the miners considered it cheaper mining to have the posts cut into the caps where the ground was heavy and spoil the caps rather than the posts. If timber was scarce, this was a very good practice.

"Although all the posts were bevelled, there were four different types of framing; at least four different types have been found. The most numerous type was that probably used altogether in drift sets, with a "horn" on one side to keep the cap from riding off. If this were the reason for the horn, one would think two horns would have been better. However only one post has been found with a horn on both sides. A third type, probably used in



Fig. 337. Mavrovouni. Ancient open stope.



Fig. 338. End portions of used (left) and unused (right) ancient timber caps placed horizontally on posts.



Fig. 339. Ancient timber, distorted by pressure from above.

stopes, had the top cut off flat, though it was bevelled in the other direction. These may have been used with headboards, though the only ones found standing in an open stope merely had a long wedge (about 18") to tighten the post. The fourth type, which is relatively rare, was notched. This notch is in the middle of the top and is only 1'4" to 3'8" deep in the five posts of this type that have been found. The four types are shown in Fig. 335.

"Another characteristic common to all posts is that the large diameter of the posts was always at the top, with the small diameter at the bottom. This agrees with the present practice. The bottoms of the posts were rounded off in every case and not cut off square. This rounding was done with an adze or an axe and was done rather roughly.

"Several posts have been found which had never been used, as they showed no signs of having supported weight. In every case the top was framed, but the bottom was cut off at a slant, as it would have come in from the forests. This would seem to indicate that the framing was done on the surface, but no standard lengths were used — the posts were cut to fit the ground, and not vice versa. This was a disadvantage if each timber was to be used several times.

"Of the posts found still in place very few if any posts were broken, although quite a few caps have been found badly bent, and cut into by the thin edge of the post tops. This would indicate the advantages of the ancient miners' framing of posts.

"No girts or collar braces have ever been found between sets, which would indicate that the horn on the posts or the notch held the caps in place. It also indicates that careful blocking and wedging was done to keep the sets from "riding".

"One post of a pony set has been found that was 18" long. The top was flat with no horn and was bevelled in the usual manner on the two sides. The bottom was notched just enough to set on top of a cap. This may have been used at the connexion of a drift with a vertical raise where more headroom than the usual 5' sets was required.

"The dimensions of the posts used by ancient miners vary from present practice; they were



Figs. 340—341. Set of ancient timber consisting of two upright (posts), cross piece (cap), and planks (lagging) above cap and outside of posts.

Fig. 342. Ancient wedges.

shorter and the diameter smaller. Twentyfour posts were measured. The maximum length was 6' and the minimum was 4' with an average of 5'. The maximum diameter at the top was 6'' and the minimum was 4'', with an average of $4\frac{1}{2}$ '', and the maximum diameter at the bottom was $5\frac{1}{2}$ ' and the minimum was $2\frac{1}{2}$ ' with an average of $3\frac{1}{2}$ '. The bevel at the top gave a maximum width of $2\frac{1}{2}$ ' in a post whose diameter was 6'', and the minimum was 1'' with an average of 2''. In those posts having a horn the horn extended 1'' to 2'' above the top of the post.

“In one of the open stopes found in the 250 level, five posts were found still in place (Fig. 337). These posts were thicker than the general average, being 5'' to 6'' in diameter, and the tops were bevelled to $2\frac{1}{2}$ ' wide. They averaged 5' 1'' long.

“Practically all the caps found to date were relatively thinner than the posts, evidently on the principle that the caps should fail before the posts. The framing was all the same, in that a notch three quarters of an inch deep was cut three or four inches from each end and the portion from the end was split out. These served to keep the posts from being pushed inward where side weight occurred. They were never trimmed to make them square, but were left round (Fig. 338).

“In only one case the cap was found to be bevelled as were the posts. This cap was 5'' in diameter, the largest yet found, and was bevelled to $3\frac{1}{2}$ ' at each end.

“Contrasted to posts, several caps have been found broken, others have been found bent (Fig. 339) one in fact was 9'' lower in the middle than at the ends, and some have been found where the sharp edge of the post cut well into the cap.

“The caps also varied in their dimensions from present practice, being both shorter and thinner. Ten caps that were measured averaged 2' 4'' in the clear (between posts), with a maximum of 2' 4'' and a minimum of 1' 8''. These averaged 2' 7 $\frac{1}{2}$ ' overall length with a maximum of 2' 11'' and a minimum of 2' 4''. The diameter averaged 3'' with a maximum of 5'' and a minimum of 2''.

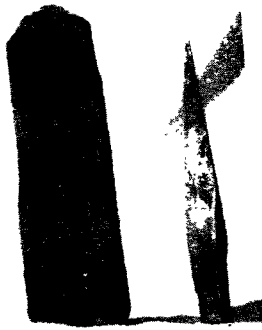

Fig. 343. Ancient wedges.



Fig. 344. Position of ancient crib-timbered shaft.

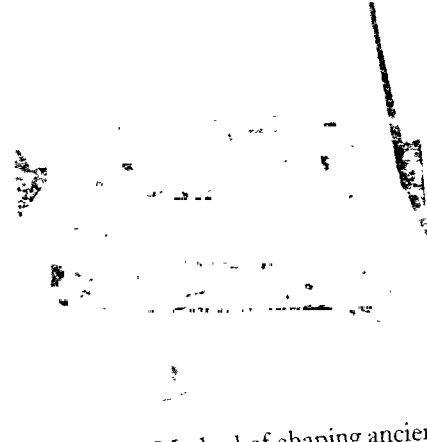

Fig. 345. Method of shaping ancient crib-timbers.

"Lagging was used by the ancient miners both on top of the caps and outside the posts (Figs. 340—341). The usual practice was to space the lagging and so to have three or four pieces on each side and four to five pieces on top. In one instance fine brush was found above the lagging; whether it was used to stop fine material running through, or to stop a cave is a question. Certainly both were good mining practice as was the spaced lagging, for the ground could be eased outside the sets and so not break them.

"The most common type of lagging used was trimmed on two sides with an adze or an axe, and was generally smaller at one end than the other. This might indicate its use as spiling, though very few pieces show that the big end was hammered. In another type the timber was left round. The third type, of which only a few examples were found, was split lagging, a piece of timber 3" in diameter was split into two pieces 1½" thick.

"Lagging was used in between sets and also with the middle of the lagging on the cap or against the post. Twenty pieces of lagging averaged 2' 8" in length and 2¼" thick. This would indicate a distance between sets of 2' approximately.

"From the lengths of posts, caps, and lagging given above, it would seem that sets were not used in stopes, but only in drifts or inclines. As the stopes average 8 feet in width, sets whose caps were 2' in the clear could hardly have been used in them to advantage. As no long caps have been found to date it is quite probable that only posts were used.

"Two rather distinct types of wedges (Figs. 342—343) have been found to date, the first, very similar to present practice, which average 9" long by 2½" wide, and slope from a thin edge to 1½" at the thick end. These were probably used in wedging sets and lagging, much as wedges are used today. A second type was from 1' 6" to 1' 10" long, 2½" to 3" wide, and sloped from 2¾" to ¾". These were probably used with posts to partly serve as T-pieces in stopes. The surprising part of the wedges found to date is that none show that they were hammered. The ends which were cut off by an adze or axe show no signs of burring caused by a hammer. A wooden mallet may have been used. The only other possibility is that the wedges had never been used. Wedges were used where needed, although sparingly, which is good mining practice today.



Fig. 346. Method of shaping ancient crib-timbers.

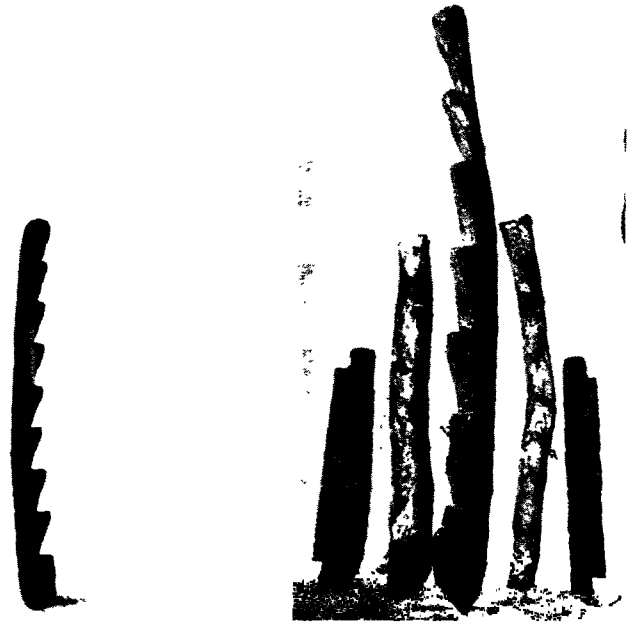

Figs. 347—348. Mavrovouni. Ancient ladders.

“Two raises or shafts have been found timbered with cribbing (Fig. 344). In both cases they were vertical and one compartment only. The cribbing in the two were evidently put in at different times or by different miners. The cribbing of the raise found on the 400 level was made of relatively large diameter timber split in half. The split was hewn flat and then some method of smoothing was used, as some cribs show no sign of adze or axe marks where they were smoothed off. This does not apply to the ends which were definitely framed with an adze or axe, and the outside, which was hewn down so as to make the section roughly rectangular. These cribsets are so smooth that they might have been cut with a rip saw. There are no signs of saw marks, but on the other hand there are no signs of adze marks; it is hardly possible that saws were used for timbers then because they would have been used in the framing of other timber.

“The method of framing cribsets (Figs. 345—346) was similar to that of caps. Both ends were notched about $2\frac{1}{4}$ ” so that when placed together the weight of the ground could not push them inwards (Fig. 346). The wide part of the cribs was placed vertically, which gave less cribs per running foot but put the weaker dimension to hold the side pressure.

“This raise was not a square, but was $2' 8\frac{1}{2}''$ by $2' 10''$ inside. Nine cribs averaged $2' 10''$ clear and $3' 4''$ overall and were $3''$ wide by $6\frac{1}{2}''$ high. The other nine averaged $2' 8\frac{1}{2}''$ clear and $3' 3''$ overall and were $3''$ wide by $6\frac{1}{2}''$ high. The hitch or notch at the ends was $2\frac{1}{4}''$ deep. The cribs of the raise found on 296 level were all hewn, and were not smoothed off as were those of the 400 level. They were cut from smaller diameter timber. The framing was similar and they were cut to a rectangular section, just as those of the 400 level.

“This raise was square, 18 cribs averaging $2' 5''$ in the clear and $2' 11''$ overall. They averaged $3''$ thick by $4''$ high and were notched or hitched $1\frac{1}{2}''$ only.



Figs. 349—351. Ancient ladder (detail), and ancient hand windlass.

“Two ladders have been found (Figs. 347—349). One was in an untimbered raise close to the cribbed raise of the 400 level and the second in a stope on 250 level. Both are of the type commonly called chicken ladder, that is to say the steps were made by notching a piece of round timber. They were both of a type used in vertical raises, the steps being perpendicular to the long axis of the piece of timber. The one found on the 400 level was 7' 8" long, 5 1/2" in diameter and the steps averaged 12 1/2" apart the maximum being 13 1/2" and the minimum 11 1/2". The width of the steps was 3". That of the 250 level was 6' 6" long, of timber 6 1/2" in diameter, and the steps averaged 8 1/2" apart, the maximum being 9" and the minimum being 8 1/4". The width of the steps was 2 3/4". These ladders would be pretty hazardous even when using both hands, and would be even more difficult when trying to carry something.

“The hand windlass (Figs. 350—351) was found inside the cribbed raise on 400 level. It was hewn from a piece of timber 8" in diameter. The drum for rope was 6 1/2" in diameter, 20 1/2" in circumference, and 6" long. The edges to keep the rope from going off the ends were 1/2" above the drum, giving a maximum diameter of 7 1/2". The overall length was 9". There was a rectangular hole in each end 1 1/2" by 1 3/4" by 2" deep on one end and 3" deep on the other end. Very probably square pegs which rested in a cradle frame were fitted into these and handles fitted to the pegs for turning. If 5 8" rope were used, only one layer of rope could have been put on the drum, due to the height of the outside ridges. The drum would take 10 wraps of 1' 8 1/2" or 17'. This indicated that the windlass was used for hoisting a relatively short distance from 15' to 16'.

“At the same point in the 400 level cribbed raise where the hand windlass was encountered considerable rope was also found. The pieces probably totalled 15' to 20' and were in a very good state of preservation, being embedded in very fine muddy silt. Six pieces of this rope averaged 5 8" in diameter. They were made up of three strands roughly 5' 16" in diameter. It was twisted similarly to modern hemp rope of the same diameter (Fig. 352).

“From the 400 level also came a piece of trough or launder (Fig. 353). A piece of round timber 4" in diameter was split and triangular or V-shaped cut made into this. The depth



Fig. 352. Fragments of ancient rope.

Fig. 353. V-shaped wooden trough.

Fig. 354. Round dowel pin hole.

of the V was 1". The piece was about 2' 6" long when found, though one end was broken off. Whether it was used to catch the drip from the cap of a drift set, or to pass water over a drift is questionable.

"The use of dowel pins to join boards was evidently common, as three pieces with dowel holes have been found. The first piece was a board broken at the dowel hole. This hole was round, 3' 8" in diameter and 2 5/8" deep (Fig. 354). The piece of board was only 13" long, smooth on one side and hewn on the other three sides. There was also found recently a second piece of hewn board in which the dowel holes were rectangular in section, 1 3/4" by 3' 8" and 1 1/4" deep (Figs. 355—357). There were two holes on each side, the centers of which were 9 1/2" and 2 1/2" apart. The third piece of timber with dowel holes was a cribset from the 400 level raise. In this the holes were 1 1/4" by 1 1/2" and 1 3/8" deep.

"Indications point to the probability that the holes of all three types were not burned, but cut by tools. The first must have been drilled with an augur, while the other was cut with chisels.

"No iron nails or nail holes in timber have been found. If nails had been used, they probably would have disappeared, but the holes could have been recognized. It is probable that dowel pins were used in place of nails.

"Three wooden knives or scrapers have come down the 400 level fill holes (Fig. 358). One was shaped like a knife with a broad blade, a second somewhat like a cleaver, while the third had no handle. The first or second may have been used to clean shovels, while the third may have been used to scrape ore or waste back from the face of a drift or stope.

"Five or six stakes have also come out of the 400 level fill holes. They were sharpened to a point on one end and cut off nearly square on the other, of tree branches 1" to 1 1/2" in diameter, and 12" long. The big ends show no evidence of hammering, unless it was done with a wooden mallet. They may have been used as survey stakes by ancient surveyors.

"Two pieces of basket have been found, plus numerous fragments. The plaits were made of round twigs roughly 1/4" in diameter. In one piece that could be saved, the vertical staves were 1" apart.



Figs. 355—357. Rectangular dowel pins and holes.

Fig. 358. Wood tools.

Fig. 359. Stone probably used as base for tin post.

“No whole lamps or jugs have ever been found, though several pieces of lamps and numerous fragments of pottery have been discovered.

“No footboards have been found, upon which posts were set to keep them from sinking into loose waste or ore. The nearest thing to this was a piece of rock 6" square by 3" thick roughly hollowed out in the centre, upon which a post could have been placed. To refute this, the stone seems to fit the hand exactly right, so it may have been used as a hammer (Fig. 359).

Mr. C. P. Manglis gives the following description of antiquities found during his developments:

1. Slab of copper found in Pedoulas Forest near small heap of manganiferous slag. This was similar in shape to that found on Parys mountain and described by T. A. Rickard in *Man and Metals*, Vol. I.
2. Remnant of basket found full of pyrites in underground workings. Bottom had been strengthened by ropes. (Fig. 360).
3. Ancient pottery lamp of 3rd or 4th Cent B. C. found in underground workings at Sha at depth of 120 feet.
4. Portion of pottery covered with slag, indicating use of pottery as crucible. (Fig. 361).
5. Pieces of crucible and microgabbro rock to which slag is attached, indicating use of these materials in smelting operations. (Fig. 361).
6. Four pieces of stone discovered at Sha and Mitsero in the pre-Roman slag and waste piles. Mr. Manglis concludes that these are stone axes used by the earliest miners of these regions. Two of the stones are cut from hard, heavy fluidal microgabbro not known to occur in the vicinity of the findings or in Cyprus. Two are composed of hard, heavy jasperoid of reddish-brown colour. (Fig. 362).
7. Iron tool, probably of Roman period, discovered in underground workings at Mitsero. No photograph or analyses are available.



Fig. 360. Remnants of basket and slab of copper.



Fig. 361. Pieces of stone and pottery with slag accretions.

At the Skouriotissa mine of the Cyprus Mines Corporation the following articles have been found:

Two pieces of antique ladder. Each of these consists of a single stick of round timber about 5 inches in diameter with notches cut about 7 inches apart in manner similar to the ladders described by Mr. Creveling, except that the step is cut at an inclination which brings



Fig. 362. Fragments of stone tools.

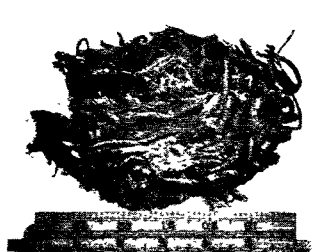

Figs. 363—364. Skouriotissa. Fragments of woven reed basket.

Fig. 365. Well preserved iron moil.

it horizontal when the ladder is inclined about 30° from the vertical. The steps had been formed with an adze.

Several specimens of woven reed baskets were found in the floors of old galleries. One of these was of light construction and probably was used as a container for the food, tools or personal belongings of the labourer. The reeds in one direction were about three sixteenths of an inch in diameter and in pairs. The crimped reeds in the opposite direction were about half this diameter and in bundles of two or three. Another specimen was of heavier construction and may have been used for heavier service, such as carrying ore. (Figs. 363—364).

Three iron tools have been found in underground workings within the boundaries of the orebody, but tightly embedded in ancient filling so that they were protected from the corrosive influence of mine waters and gases. One of these tools is in the shape of a gad or moil with badly battered head. It is about 6 inches long and of shape shown by Fig. 365. It was completely enclosed within a heavy coating of grey iron sulphate which doubtless had been formed by the corrosion of SO_2 gases in the absence of water. This sulphate was tightly cemented to the iron and no doubt served to protect it from further corrosion. The point of the tool had apparently been hardened by tempering to about 5, Moh's scale. Analysis showed 97.2 % iron and 0.4 % copper. The presence of the copper indicates that this tool probably was made from copper-bearing iron oxides resulting from the roasting of Cyprus copper ores.



Fig. 366. Iron hoe partially corroded.



Fig. 367. Fragments of clay pipe found in ancient working.



Figs. 368—369. Skouriotissa. Views of large dump of broken pottery outside ancient mine.

Another tool was shaped like a broad adze or hoe (Fig. 366). The original width of the blade was about 6 inches, and the hole for handle about one inch in diameter. It is not possible to detect whether this was used as an adze for shaping timber or as a hoe for scraping the ore. The head opposite the blade shows indications of having been somewhat battered. Analysis shows 97.1 % iron and 0.4 % copper.

The third iron tool is so badly corroded that it is not now strongly magnetic and its original shape cannot be stated with certainty. It appears to have been made with one blade in the plane of the handle and one at right angles to the handle, so that it might have been used as a combination axe and adze. The corrosion and alteration is so great that analysis was not considered worth while.

Three Roman pottery lamps were found underground at the Skouriotissa mine. These evidently were used by the miners for burning olive oil.

Piece of clay pipe tiling found underground. The inside diameter is about $4\frac{1}{2}$ inches and outside diameter $5\frac{1}{2}$ inches. It may be noted that it is not of the modern bell and spigot type as the pipe section has been reduced to enter into the next section of pipe, whereas modern bell and spigot types have one end enlarged to pass over the end of the next section. The pipe obviously has been made on the potter's wheel. (Fig. 367).

Fig. 2 shows partially reconstructed earthenware jar such as were used by the slaves at the time of Galen's visit (166 A. D.) for carrying sulphated mine water from underground workings to surface. This was reconstructed from fragments found in a large ancient dump of broken jars shown in Figs. 368—369, one of which gives a view of modern stairway passing over the remains of the ancient dump. This stairway leads to the miners' change



Fig. 370. Polished cross section of wood found in ancient mine workings, showing metallic copper which has been deposited during the centuries the wood lay buried. Figs. 371—372. Ancient mine timber.

house which now stands on the site beneath which foundation of ancient building was discovered. This, in all probability, is the foundation of the building described by Galen as being near to the entrance of the ancient mine gallery.

Recently a bronze coin was discovered while excavating an ancient opencast site at Mathiati, dating from the reign of Constantinus II in the early 4th century. It was found under consolidated fill, which indicates that it was current during mining operations about that time.



Fig. 373. Skouriotissa. View south from Foukassa Hill, showing "Pre-Roman" slag (foreground) and part of "Roman" slag (right centre).



Fig. 374. Mathiati. Various tools recently found in what might have been the site of a workshop.

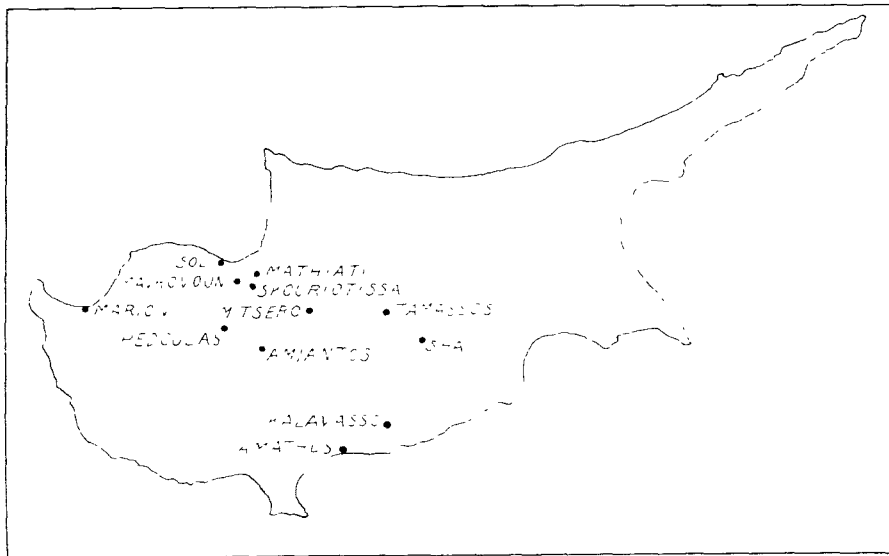

Fig. 375. Map of Cyprus with mining centres indicated.

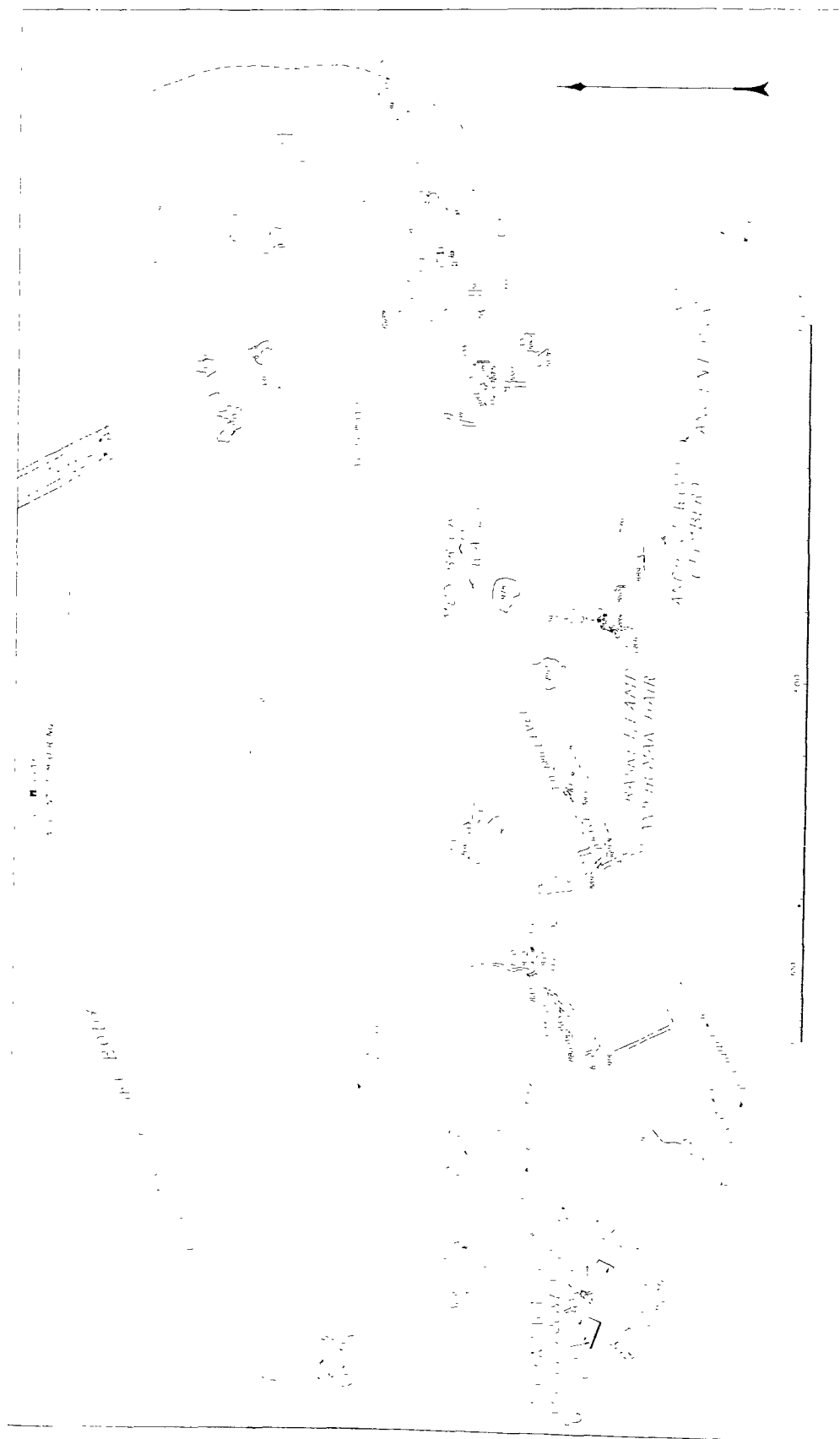

Fig. 376. Skouriotissa. Plan of orebody with ancient underground working pottery dump.

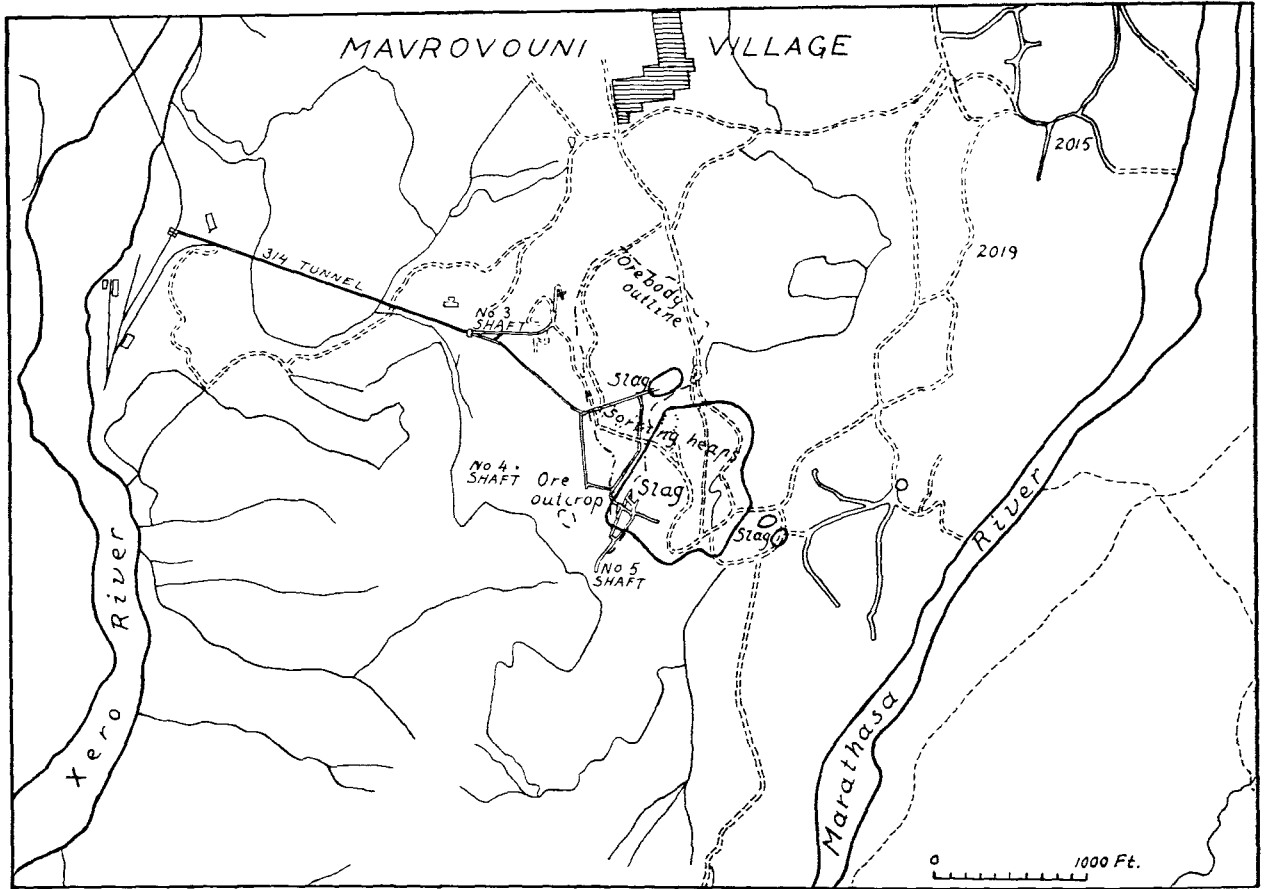

Fig. 379. Mavrovouni. Plan of orebody with ancient slag piles.

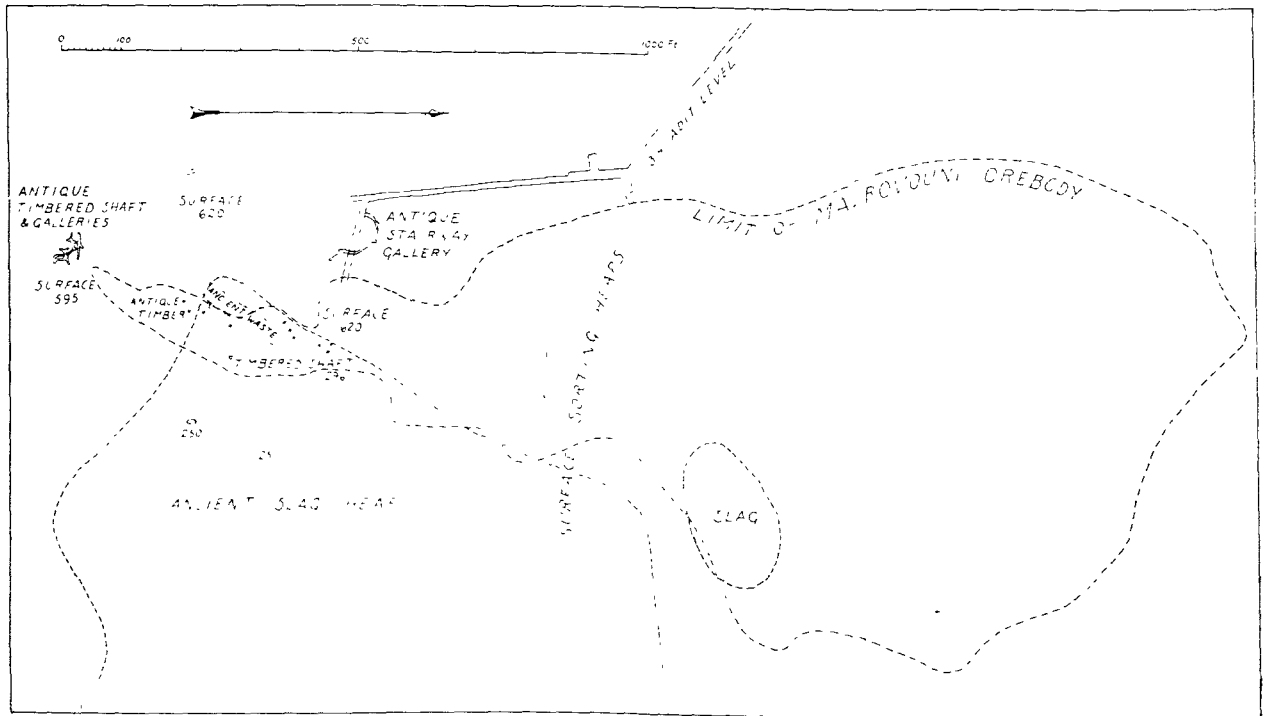

Fig. 380. Mavrovouni. Plan and elevations of ancient workings.

400' above Sea Level

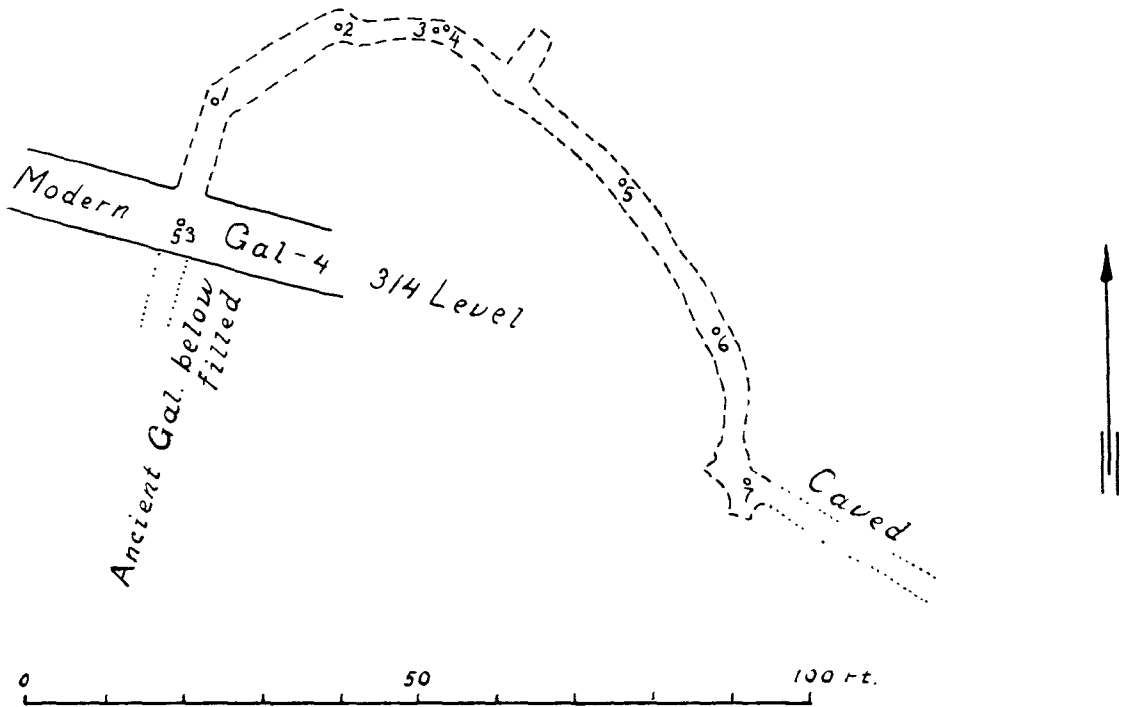
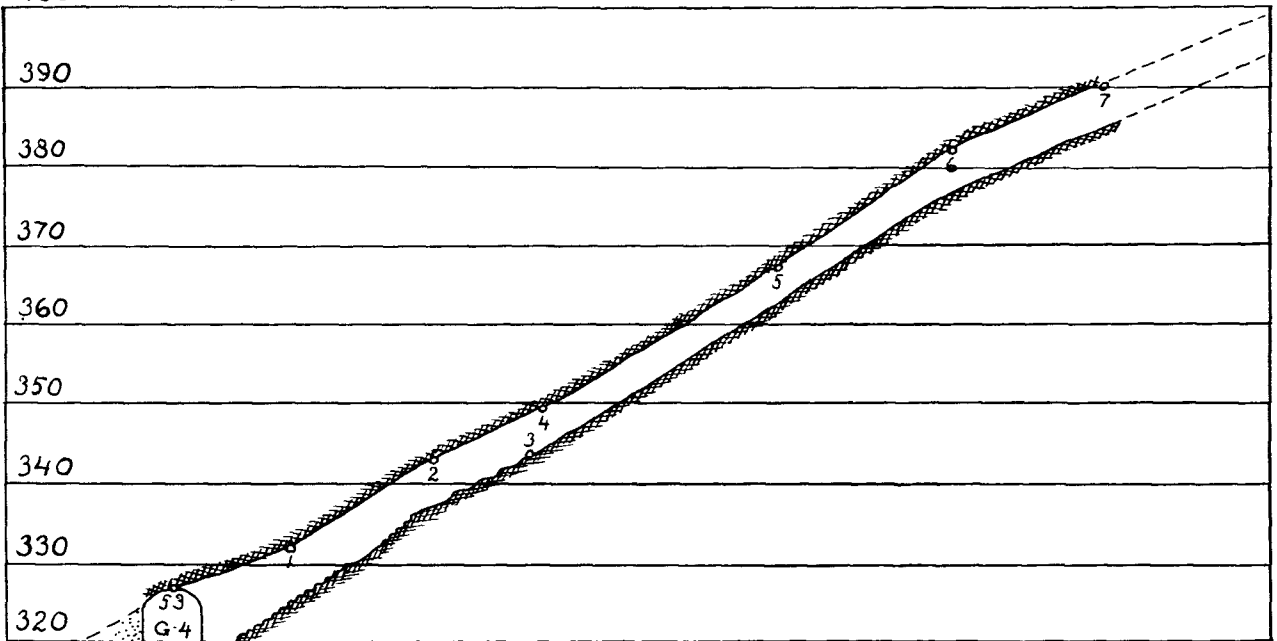

Fig. 381. Mavrovouni. Plan and cross section of ancient stairway gallery on 314 ft. level.

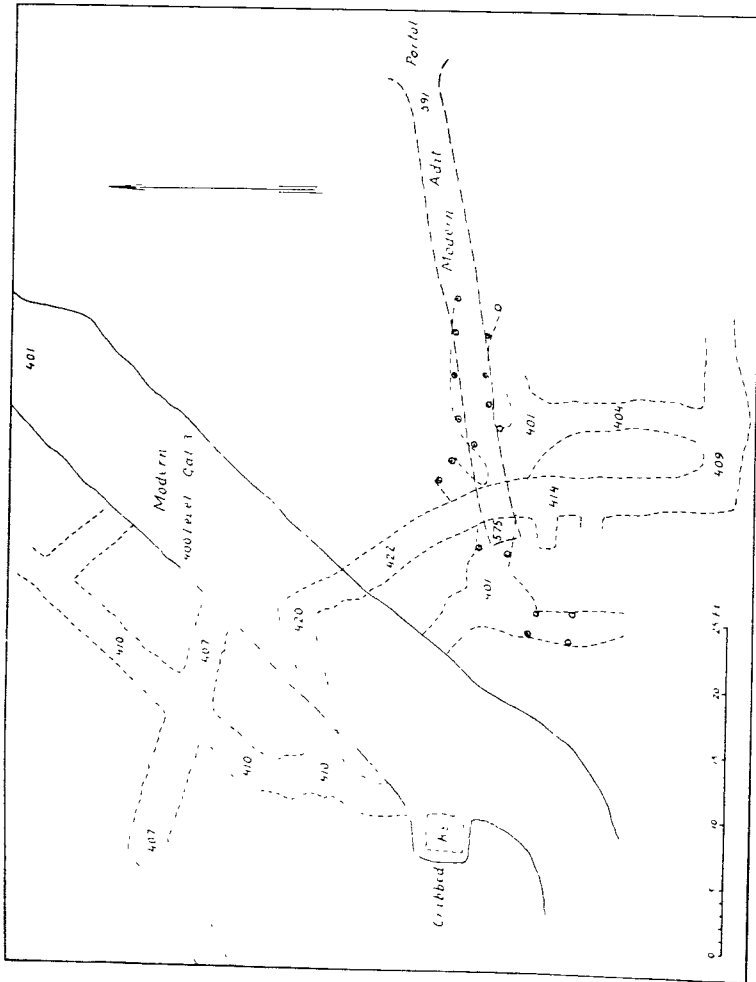

Fig. 382. Mavrovouni. Plan and elevations of ancient workings on 400 ft. level.

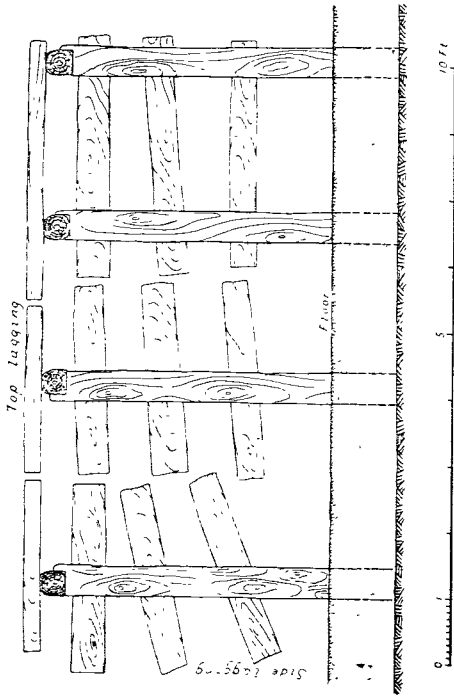

Fig. 383. Details of antique timber sets.

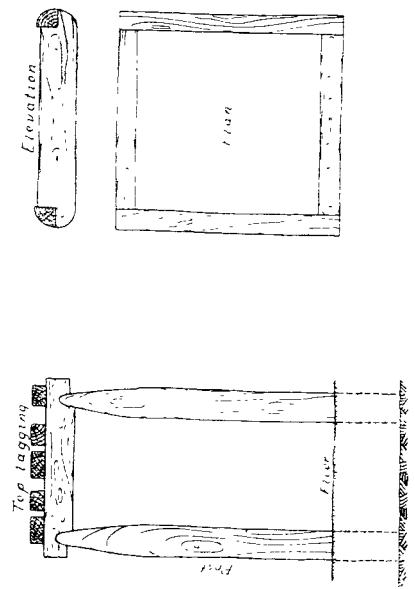

Fig. 384. Details of timber post set and timber.

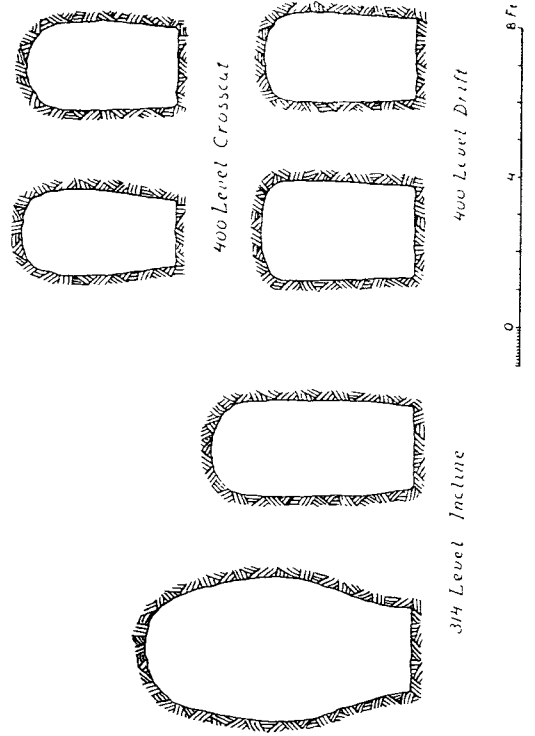

Fig. 385. Cross sections of various ancient galleries.

NOTES

- 1 Translations of the parts relating to Cyprus in the third chapter of the ninth book of Galen's works in eleven books on *Materia Medica* entitled "*Temperaments and Faculties of simple drugs*", Kuhn edition, Volume XII. Translation published in "*The Bulletin of the Geographical Society of Philadelphia*" Volume XXV, No. 3.
- 2 There were others near Amathus, and on the slope of the central mountain range.
- 3 In my opinion this was copper sulphate. — J. L. B.
- 4 "*Excerpta Cypria, Materials for a History of Cyprus*", trans. by Claude D. Cobham, Cambridge University Press, 1908.
- 6 "Copper Mining in Cyprus" published as a paper of the British Institution of Mining and Metallurgy, March, 1930.
- 7 "The Cyprus Mines Enterprise", *Engineering & Mining Journal*, Vol. 126, No. 2, July, 1928.
- 8 E. Oberhammer, "*Aus Cypern*", *Zeitschrift der Gesellschaft für Erdkunde*", Vol. XXV, p. 224, 1890.

It is possible that the deepest workings were carried out during extended periods of drought. One such period is reported to have occurred about 300 A. D. when there was very little rainfall for 36 years.

- 9 The following definitions are given for the benefit of those unacquainted with mining terms:

- Post — Timber used in the upright position to support the roof of hanging wall of any underground opening; a prop or stull.
- Cap — Piece of timber placed on top of a post.
- Set — Term used to denote a unit of supporting timbers consisting of uprights and cross pieces. As used by the Romans a set consisted of two posts surmounted by a cap for spanning the width of the tunnel. A pony set is a small one above the regular set.
- Frame — A verb meaning to shape timbers for fitting together in a set.
- Lagging — Planks, slabs or small pieces of timber placed over caps or behind posts, used not to carry the main weight but to form a ceiling or wall to prevent fragments or rock from falling through. The smaller the rock fragments to be held, the nearer together are pieces of lagging placed.
- Cribbing — A structure of composed pieces of timber laid horizontally one upon another as in the walls of a log house.
- Headboard — A flat piece of wood placed under the roof of stope or gallery and supported by post.
- Footboard or footblock — Flat piece of wood placed under posts, to give a broad base and thus prevent the superincumbent weight from pressing the posts into the ground.
- Stope — Term used herein as a synonym for room, which is a wide working place in ore.
- Drift — A horizontal passage underground. A drift follows the vein as distinguished from a crosscut, which intersects it or a level or gallery, which may do either.
- Girt — A horizontal brace at right angles to the cap. A collar brace is a girt at the upper ends of posts.
- Spiling — Temporary lagging driven ahead of main timbering to support the roof or sides in advancing a level in loose ground.

A P P E N D I X VI

Dr. Nils Zenzén, of Naturhistoriska Riksmuseets mineralogiska avdelning, Stockholm, has kindly examined some of the materials used for the sculptures. In a letter to me, he has given the results of these examinations.

According to Dr. Zenzén, the piece of MARBLE which he examined, belongs to a marble which seems to derive from a series of chrySTALLINE schists, the calcite grains, as a rule, showing repeated twinning. It appears impossible to determine whence it comes but most likely from the Greek islands.

The piece of ALABASTER has the character of the so-called Egyptian alabaster, the "*alabastritis*" of Antiquity, which is no alabaster in the modern sense as it is not constituted of gypsum but of calcite (without twinning). Dr. R. Blix has determined its specific gravity to 2.74. According to Dr. Zenzén, this kind of alabaster was probably not found outside Egypt.

The rock which has been called SOFT LIMESTONE above, is a marl which, according to Dr. Blix contains 15.5 % clay. With the naked eye one cannot see any fossils but on a slide, the microscope reveals the rock being built up of foraminifera. According to Dr. F. Brotzen, the rock should be called a globigerina-marl and after a preliminary determination he estimates its age to be Upper Cretaceous or Eocene.

The rock called HARD LIMESTONE is a porous limestone, very rich in fossils. According to Dr. N. Hj. Odhner, those visible to the naked eye are various kinds of molluscs. In thin sections there also appear foraminifera and bryozoa. Dr. Brotzen has preliminarily determined the age of the rock to late Tertiary or younger. In any case, it is of considerably younger date than the globigerina-marl (our soft limestone). These two kinds of limestone, consequently, belong to quite different parts of the geological sequence and, therefore most likely, originate from different localities.

A. W.

N O T E S

KITION

- 1 Oberhummer, in Pauly-Wissowa, *Real-Encyclopädie d. Class. Altertumswiss.*, art. *Kition*
- 2 Hill, G. F., *Catalogue of the Greek Coins of Cyprus in the Brit. Mus.*, London 1904, p. 60; Pl. XII, 6—8
- 3 Svoronos, J. N., *Tà νομίσματα τοῦ κράτους τῶν Πιολεμαίων*, Athen 1904, Pl. XVII, 8, 17; Hill, *op. cit.*, p. 57.
- 4 Hill, *op. cit.*, p. 67; Pl. XV, 7; Svoronos, *op. cit.*, Pl. XXXIX, 4—7
- 5 Macdonald, G., *Catalogue of Greek coins in the Hunterian Collection*, I, Glasgow, 1899, p. 339; Pl. XXIII, 17.
- 6 Head, V., *Historia numorum*, Oxford 1911, p. 363; Anson, L., *Numismata graeca*, III, London 1912, p. 55
- 7 Hill, *op. cit.*, p. CXX; Pl. XXVII.

VOUNI

THE PALACE

- 1 Babelon, E., *Catalogue des monnaies grecques de la Bibliothèque Nationale, Les Perses Achéménides*, Paris 1893, pp. XIV, 1 ff.; Pl. I, 1—15; Babelon, *Traité des monnaies grecques et romaines*, I: 2, Paris 1907, pp. 258 f.; Pl. X, 13—18; Hill, G. F., *Catalogue of the Greek Coins of Arabia, Mesopotamia, and Persia in the Brit. Mus.*, London 1922, Pl. XXIV, 1—11
- 2 Babelon, *Les Perses Achéménides*, pp. XIV f., 6 ff.; Pl. I, 22—27; Babelon, *Traité*, II: 2, pp. 43 ff.; Pl. LXXXVI, 3—9; Hill, *op. cit.*, Pl. XXIV, 24—28
- 3 Imhoof-Blumer, F., *Kleinasiatische Münzen*, II, Wien, 1902, pp. 310 f.; Taf. X, 15; Hill, G. F., *Catalogue of the Greek coins of Lycia, Pamphylia, and Pisidia in the Brit. Mus.*, London 1897, p. 95; Pl. XIX, 12 ff.
- 4 Hill, *Cat. Gr. coins of Cyprus*, pp. LVII f., 32; Pl. VI, 9, 10
- 5 Hill, *op. cit.*, pp. LVIII, 33; Pls. VI, 11, XX, 4—6
- 6 Hill, *op. cit.*, pp. XXXII, 10 ff.; Pls. III, 1—9, IV, 5—16.
- 7 Hill, *op. cit.*, pp. XXXIII, 13 ff.; Pls. III, 10—14, IV, 1—4
- 8 Hill, *op. cit.*, pp. XXXVII ff., 21; Pls. IV, 9, XIX, 9—13
- 9 The types of coins are similar to those of Hill, *op. cit.*, Pls. VII, 10—21, XXI, 7—11
- 10 For this type of coin cf. Hill, *op. cit.*, p. XXV. The attribution to Amathus is conjectural
- 11 Hill, *op. cit.*, pp. 24 ff.; Pl. V
- 12 Hill, *op. cit.*, pp. XXXII f.
- 13 *Comptes rendus de l'Académie des Inscr. et B. L.*, XV, 1887, pp. 203 ff.
- 14 Hill, *op. cit.*, pp. XXXII f.
- 15 Hill, *op. cit.*, p. XXXVIII

SOLI

NOTES ON ANCIENT RECORDS

- 1 Engel, W., *Kypros*, I—II, Berlin 1841.
- 2 Meursius, *Creta, Cyprus et Rhodos*, Amsterdam 1675.
- 3 Plutarch, *Sol.*, 26.
- 4 For the different kinds of writings, see Oberhummer, in Pauly-Wissowa, *Realenc.*, article *Soloi*.

- 5 Strabo, XIV, 683.
- 6 Oberhummer, E., *Die Insel Cypern*, Munchen 1903, p. 12 ff.
- 7 Herodot, V, 110—115.
- 8 Engel, *op. cit.*, I, p. 297.
- 9 Plutarch, *Alex.* 29.
- 10 Arrian, *Indian Exp.*, C. 18.
- 11 Strabo, XIV, 683.
- 12 Engel, *op. cit.*, I, p. 357.
- 13 Strabo, XIV, 683; Diodor, XVIII, 3.
- 14 Oberhummer, in Pauly-Wissowa, *Realenc.*, article *Eunostos*.
- 15 Cf. Westholm, A., *The Temples of Soli*, Stockholm 1936, pp. 186 ff.
- 16 Oberhummer, in Pauly-Wissowa, *Realenc.*, article *Soloi*.
- 17 Strabo, XIV, 683.
- 18 Engel, *op. cit.*, I, p. 217 ff.
- 19 Oberhummer, *Die Insel Cypern*, p. 203.
- 20 Oberhummer, in Pauly-Wissowa, *Realenc.*, article *Limenia*.
- 21 Cf. *Swed. Cyp. Exp.*, I, p. 1.
- 22 *Acta Sanctorum*, *De S. Auxibio*, § 3.
- 23 *Acta Sanctorum*, *De S. Barnbae*, § 25.
- 24 *Journal of Hellenic Studies*, XI, 1890, p. 88.
- 25 *Acta Aux.* § 3, Limne vicus: Ἐν κόμῳ τῷ καὶ ὀνομαζέσθαι Λιμνῆς *Hervetus legit* λιμνὴν *verit enim. in vico qui vocabatur Portus. Paulo post λιμνῆς τῆς vocat, vel pagum ipsum vel tractum circumjectum. Διῆς τῆς ἐστὶ τῷ Λιμνῆς τῆς.*
- 26 E. g., Constantia.
- 27 The two MSS are the *Parisin. No. 1452, Catalogus Codicum Hagiographicum Graecorum Bibliothecae Nationalis Parisiensis*, Paris 1896, No. 1452, 26, Fol. 153—159, translated in the *Acta Sanctorum*, febr. III, pp. 124—128, and the *Vindobon.*, *Hist. Gr. XI*; cf. Lambeck-Kollar, *Commentariorum. L. VIII*, p. 151; Lipomanus, A., *Tomus quintus vitarum sanctorum patrum*, fol. 563—573.
- 28 Lipomanus, A., *Sanctorum priscorum patrum vitae*, Venice 1551—60, pp. 569—573.
- 29 Baudrillart, A., *Dictionnaire d'Histoire et de Géographie Ecclésiastiques*, V. Paris 1931, p. 958.
- 30 Oberhummer, in Pauly-Wissowa, *Realenc.*, article *Soloi*.
- 31 *Galen Opera Omnia*, Leipzig 1821, XX, 238.
- 32 Walsh, J., in *The Bulletin of the Geographical Society of Philadelphia*, XXV, 3, p. 93.
- 33 di Cesnola, L. P., *Cyprus: its ancient cities, tombs and temples*, London 1877, pp. 229 and 425.
- 34 Cf. Hogarth, D. G., *Devia Cypria*, London 1889, p. 114.
- 35 Cf. Oberhummer, in Pauly-Wissowa, *Realenc.*, article *Soloi*.
- 36 Acts of Apostles XIII, 7.
- 37 Lipomanus, *op. cit.*, p. 572; *Acta Sanct.*, Febr. III, p. 130.
- 38 Hachett, J., *History of the Orthodox Church of Cyprus*, London 1901, p. 323.
- 39 Lusignan, Fr., *Chorographia et brevis historia unversale dell'isola de Cipro*, Bologna 1573, p. 86.
- 40 Pockocke, R., *Description of the East*, II, 2, London 1745, p. 223.
- 41 di Cesnola, *op. cit.*, p. 229.
- 42 Hogarth, *op. cit.*, p. 113.

THE TEMPLES AT CHOLADES

- 1 Svoronos, *op. cit.*, II, p. 47, No. 277; Pl. X, 7
- 2 Svoronos, *op. cit.*, II, p. 57, No. 363; Pl. XI, 9
- 3 Svoronos, *op. cit.*, II, p. 187, No. 1159; Pl. XXXIX, 7; cf. Regling, K., in *Zeitsch. f. Num.*, 1905, p. 371
- 4 Svoronos, *op. cit.*, IV, p. 314. Cf. II, p. 264, No. 1636; Pl. LIV, 14
- 5 Svoronos, *op. cit.*, IV, p. 334
- 6 Svoronos, *op. cit.*, II, p. 304, No. 1842; Pl. LXI, 27—28; IV, p. 358
- 7 Cf. Hill, G. F., *Cat. Gr. coins of Cyprus*, p. CXXXVII; Pl. XVI, 6
- 8 It is like Mattingly and Sydenham, *Roman Imperial Coinage*, London 1923—, III, p. 165, No. 1145
- 9 Cohen, H., *Description historique des monnaies frappées sous l'empire romain*, IV, Paris 1884, p. 6, No. 21
- 10 It is like Hill, *op. cit.*, p. 86, No. 57
- 11 Cf. Hill, *op. cit.*, Pl. XVII, 8, 9

- 12 Cohen, *op. cit.*, V, p. 26, No. 44
- 13 It is similar to Cohen, *op. cit.*, IV, p. 515, No. 105
- 14 Mattingly-Sydenham, *op. cit.*, V: 1, p. 308, No. 386
- 15 Mattingly-Sydenham, *op. cit.*, V: 1, p. 309
- 16 Cohen, *op. cit.*, VI, p. 523, No. 311
- 17 Cohen, *op. cit.*, VII, p. 289, No. 515
- 18 Cohen, *loc. cit.*
- 19 Maurice, *J. Numismatique Constantiniennne*, Paris 1908—1912, II, p. 518; Pl. XVI, 1
- 20 It is similar to Maurice, *op. cit.*, I, Pl. XX, 19
- 21 Maurice, *op. cit.*, I, p. 313, Pl. XX, 8
- 22 Maurice, *op. cit.*, III, p. 201
- 23 Maurice, *op. cit.*, III, p. 123, 142; Pl. V, 7
- 24 Maurice, *op. cit.*, II, p. 44; Pl. II, 12
- 25 Maurice, *op. cit.*, III, p. 117; Pl. V, 2
- 26 Goodacre, H., *The bronze coinage of the Late Roman Empire*, London 1922, p. 73
- 27 Wroth, W., *Catalogue of the Imperial Byzantine Coins in the Brit. Mus.*, London 1908, p. 225, No. 283
- 28 Broneer, O., *Excavations at Corinth IV, Terracotta lamps*, Cambr. Mass. 1930
- 29 Loeschcke, S., *Lampen aus Vindonissa*, Zürich 1910
- 30 Macrobius, *Saturn.*, I, 20, 13
- 31 Wilcken, U., *Die griechischen Denkmäler am Dromos des Serapeums von Memphis*, in *Jahrbuch des deutschen archäologischen Instituts*, 32 (1917), p. 190
- 32 *Journal of Hellenic Studies*, IV, 1883 p., 293
- 33 Schmidt, V., *Ny Carlsberg Glyptothek, Den Aeg. Saml.*, København 1908, p. 494, No. E. 542
- 34 Schreiber, Th., *Alexandrinische Toreutik*, Abhandl. Phil.-hist. Klasse, Kön. Sächs. Ges. d. Wiss., Bd. 14, No. 5, 1894, Pl. I b
- 35 Breccia, E., *Rapport sur la marche de service du musée*, Alexandria 1921—1923, p. 24, Pls. XIX—XX; *Alexandrea*, Bergamo 1923, p. 359, Fig. 355; *Monuments de l'Égypte Gréco-Romaine* II, Bergamo 1930, Tav. XL, 9—11
- 36 Weber, W., *Die Ägyptisch-Griechischen Terrakotten*, Berlin 1914, p. 19

THE THEATRE

- 1 Vitruvius, *De architectura*, V, 6, 1
- 2 Vitruvius, *op. cit.*, V, 6, 3
- 3 Hill, G. F., *Catalogue of the Greek coins of Palestine in the Brit. Mus.*, p. 236; Pl. XXVI, 1, 2
- 4 Hill, *op. cit.*, pp. 272 ff.; Pl. XXX, 11—14
- 5 Cohen, H., *op. cit.*, II, p. 287, No. 134; Mattingly and Sydenham, *op. cit.*, III, p. 154, No. 1050; Hill, G. F., *Cat. Gr. coins of Cyprus*, p. 85, Nos. 52, 53; Pl. XVII, 2, 3
- 6 Mattingly-Sydenham, *op. cit.*, V: 2, p. 121; Pl. V, 15
- 7 Goodacre, H., *op. cit.*, p. 20; Maurice, *op. cit.*, III, p. 202
- 8 Wroth, *op. cit.*, I, p. 171



